

STEP 1

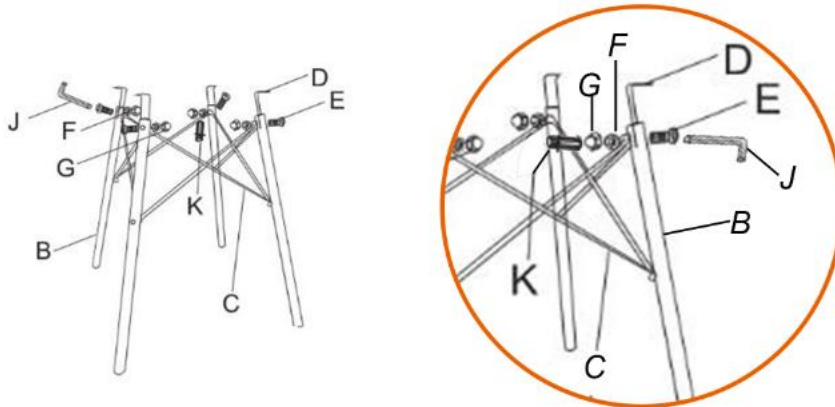

Use components: 4*B(legs), 4*C(metal frame), 4*D(L shaped Iron sheets),

Use hardwares: 1*J and 1*K(tools), 4*E, 4*F, 4*G

Step1:

Tighten the upper 4 screw holes on top of the legs;

J and K are 2 tools to help you easily tighten the screws;

E,F,G are a set of screw components for a hole, you need 4 sets.

STEP 2

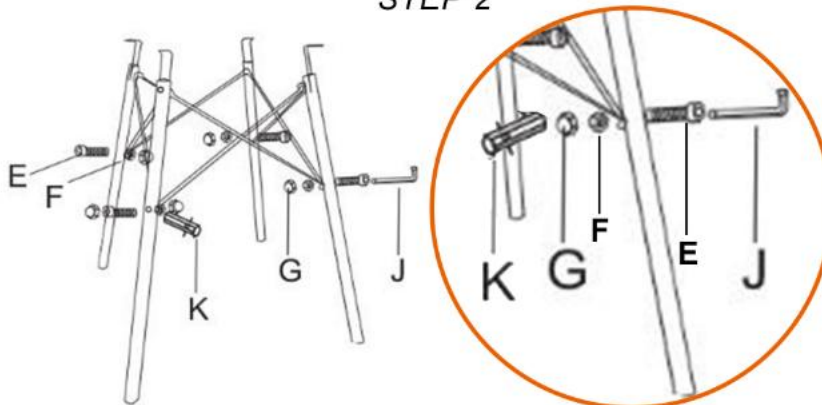

Use hardwares: 1*J and 1*K(tools), 4*E, 4*F, 4*G

Step2:

Tighten the lower 4 screw holes on the middle of the legs;

J and K are 2 tools to help you easily tighten the screws;

E,F,G are a set of screw components for a hole, you need 4 sets.

STEP 3

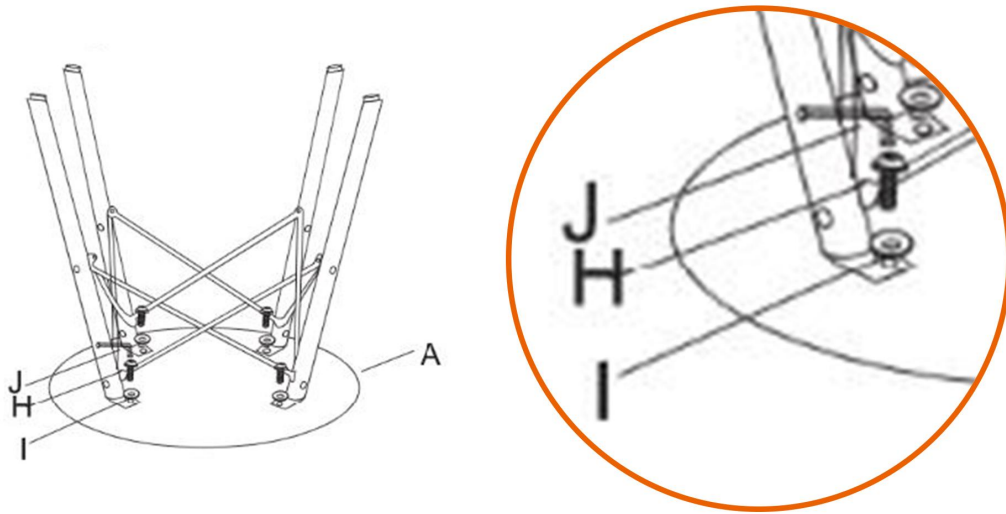

*Use hardware: only 1*J (tools), 4*H, 4*I*

Step3:

Attatch table top and legs.

Use a dry cloth on the floor to protect the table top(A);

J is a tool to help you easily tighten the screws;

H and I are a set of screw components for a hole, you need 4 sets.

Check all screws and make sure all screws are tightened.