





Thank you for purchasing the **BED !**





Before you start, here is some helpful advice:

1. We suggest you spend a short time reading through this leaflet and then follow the simple step by step instructions.
2. Owing to the size and weight of the bed, we recommend that it is assembled by two adults, on a carpeted or padded area, in the room that it is intended for. Approx assembly time: 30 minutes.
3. Please do not use any tools other than those provided or recommended in these instructions.
4. Please do not throw away any of the packaging or the instruction until you have checked all the components and hardware and the furniture is fully assembled. Please ensure that the packaging is disposed of in a safe environmentally friendly way.
5. Assemble all components loosely until advised to tighten. Depending on use, it may be necessary to tighten the components from time to time, so please save the tools that has been provided.
6. Please keep all fitting out of reach of children.

### Hardware for Headboard

A		JCBC SCREW M6 X 40MM	<b>x12</b>
B		FLAT WASHER 1/4"	<b>x12</b>
C		SPRING WASHER 1/4"	<b>x12</b>
D		M4 ALLEN KEY (BALL SHAPE) LONG	<b>x1</b>
E		BOLT BASE GLIDE M6 x 23(C83)	<b>x2</b>

### Hardware for Bed Frame and Legs

F		JCBC SCREW M6 X 35MM	<b>x2</b>
G		JCBC SCREW M6 X 40MM	<b>x12</b>
H		SPRING WASHER 1/4"	<b>x14</b>
I		FLAT WASHER 1/4"	<b>x14</b>
J		WOOD DOWEL DIA 8 x 25MM	<b>x2</b>

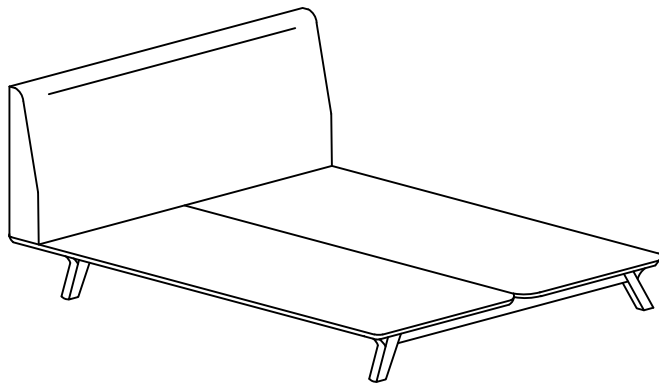

Component :

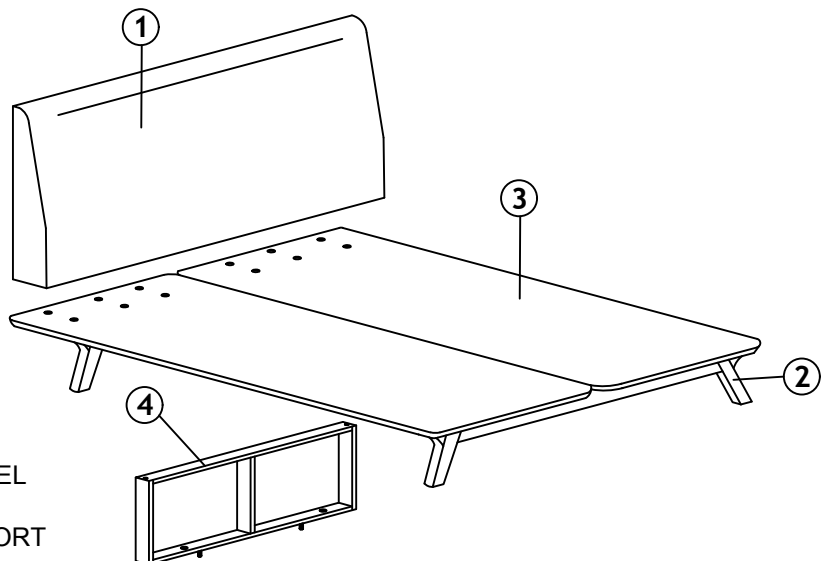





- 1- HEADBOARD
- 2- LEGS
- 3- MATTRESS PANEL
- 4- WOODEN SUPPORT

---

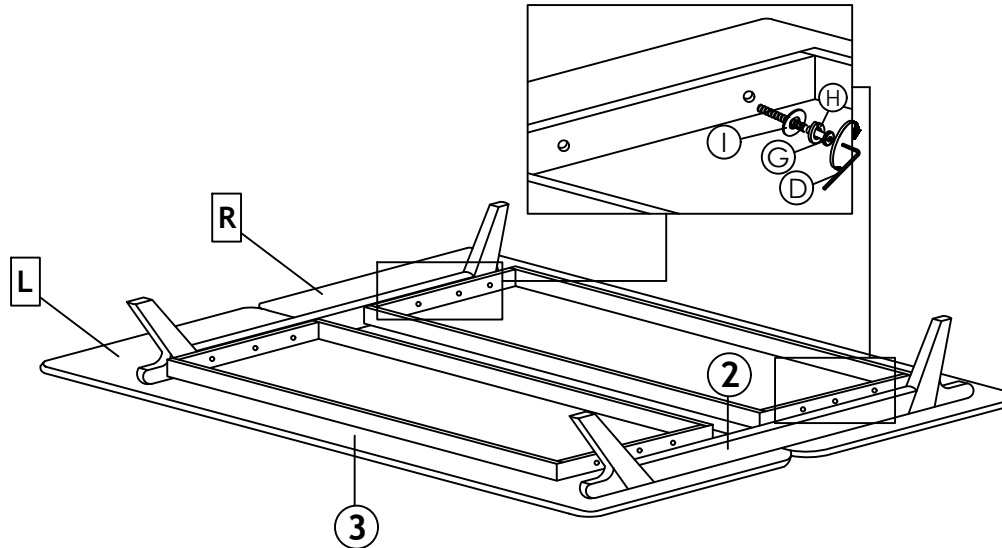
**STEP 1 :**

Place **Mattress Panel (3)** and **Legs (2)** on a carpeted or padded area as shown. Attach **Legs (2)** into **Mattress Panel L & R (3)** by inserting **JCBC SCREW M6 x 40mm(G)**, **Spring Washer  $\frac{1}{4}$ "(H)** and **Flat washer  $\frac{1}{4}$ "(I)**. Tighten with **M4 Allen Key (Ball Shape)Long(D)**.



			
G x 12	H x 12	D x 1	I x 12





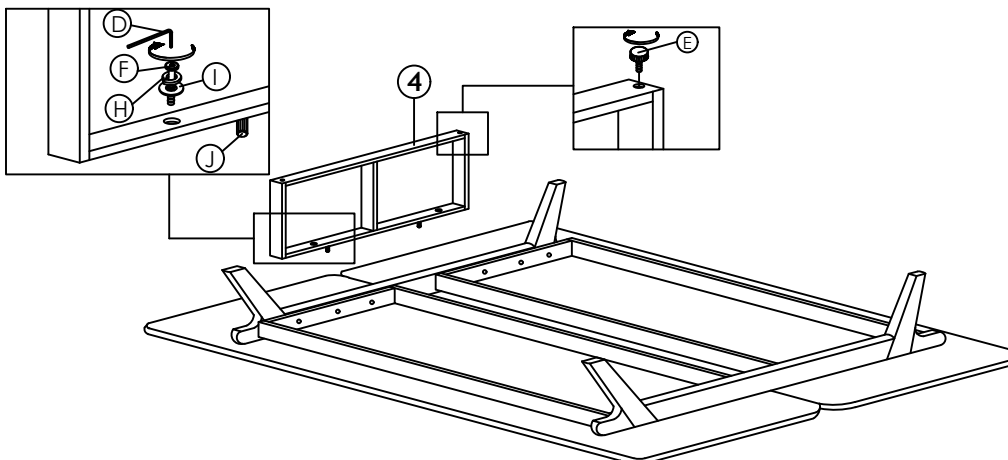

**Hardware & Tool required**

---

**STEP 2 :**

1. Secure the **Wooden Support(4)** by using **Bolt Base Glide M6 x 23(C83)(E)**. Insert the wooden dowel into the bottom holes on each side of the **Wooden Support(4)**.
2. Attach **Wooden Support(4)** first by inserting the other end of the wooden dowel(J)into the corresponding holes on the **Mattress Panel(3)**,and then secure by inserting **JCBC SCREW M6 x 35mm(F)**, **Spring Washer  $\frac{1}{4}$ "(H)** and **Flat Washer  $\frac{1}{4}$ "(I)**. Then,tighten with **M4 Allen Key(Ball Shape)Long(D)**.



					
F x 2	H x 2	D	I x 2	E x 2	J x 2

**Hardware & Tool required**

---

**STEP 3 :**

Flip the assembled **Mattress Panel(3)** over. Place the **Headboard(1)** on the **Mattress Panel L&R(3)** and attach them by inserting **JCBC SCREW M6 x 40mm(A)**, **Flat Washer $\frac{1}{4}$ "(B)** and **Spring Washer $\frac{1}{4}$ "**

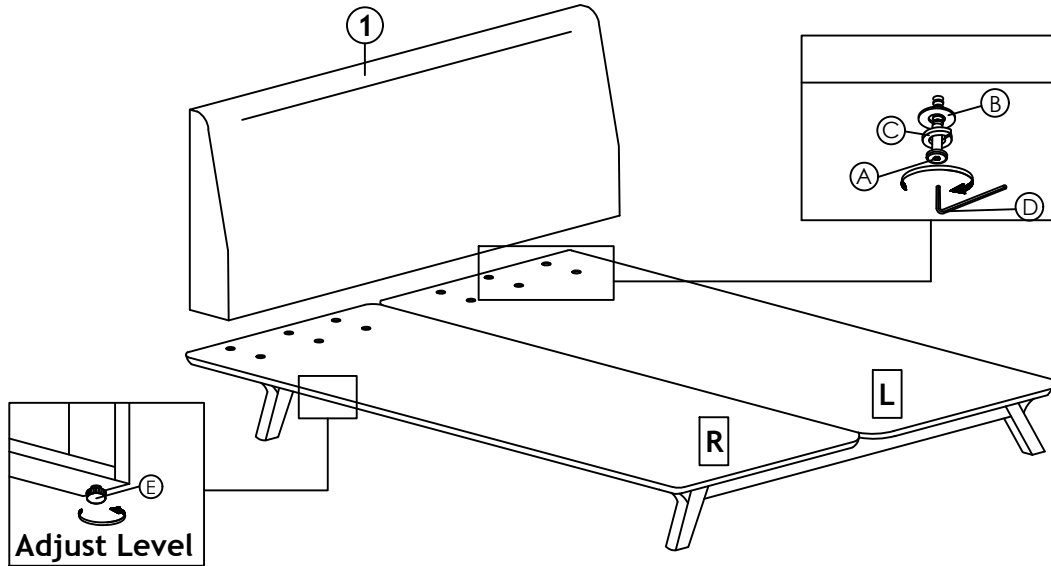

				
A x 12	C x 12	D	B x 12	E

**Hardware & Tool required**

---

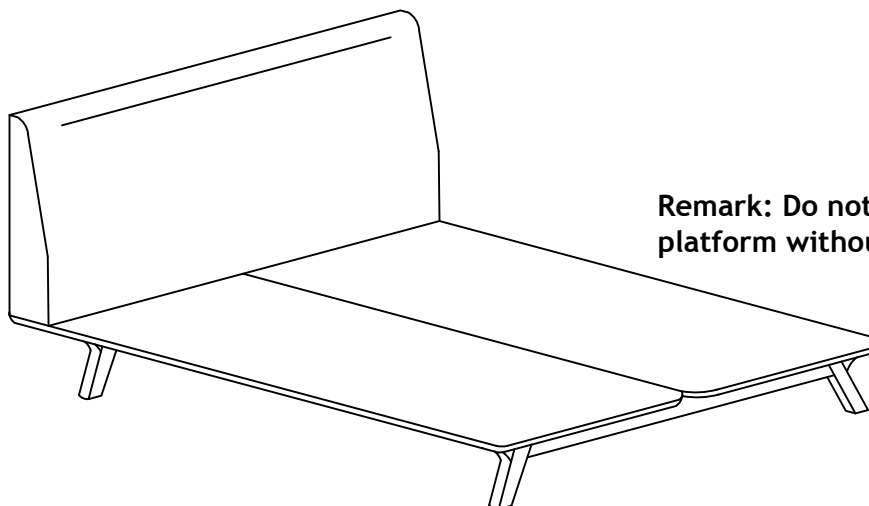
**STEP 4 :**

**Remark: Do not sit or lie down on the platform without the mattress**

Assembly is complete, the bed is ready to be enjoyed now!