

PS-104

FEATURES:

- * Bowl Size: 17-1/2" x 14-1/8" x 6"
- * Material: Vitreous China
- * For Under Counter Use
- * Recommended Drain: DS-001
- * For Drains with Overflow
- * For Use With Standard Pop Up Drain
- * Warranty: One Year Limited Warranty
- * Includes Mounting Clips

CODES / STANDARDS APPLICABLE

- * CSA B45
- * ASME A112.19.2

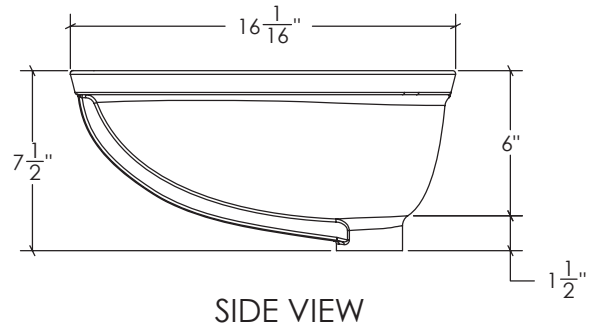
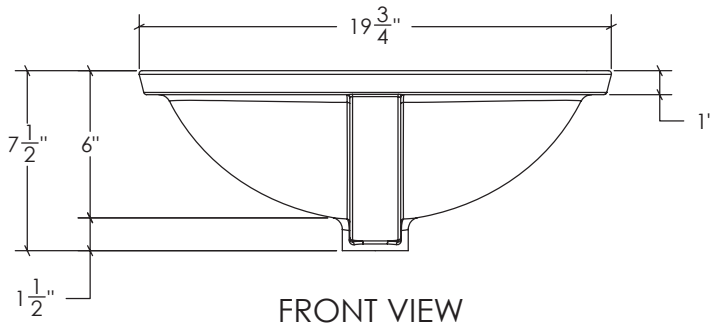
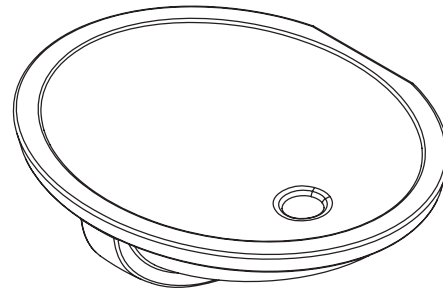
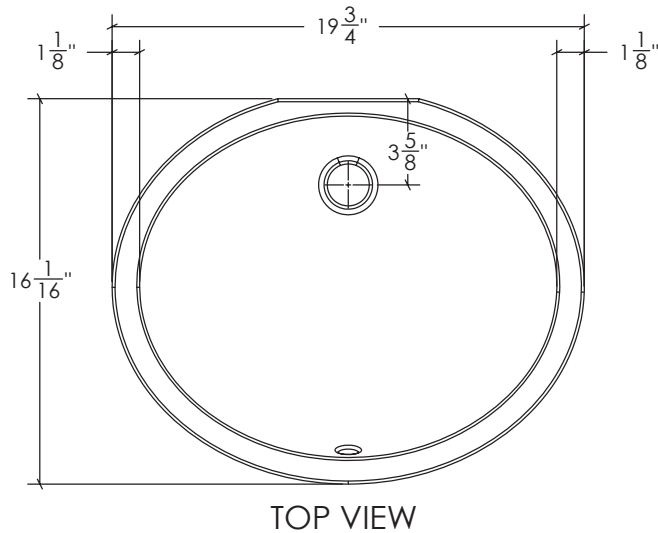

JOB INFORMATION:

Job Name _____
 Date Specified _____
 Contractor _____

Specifications and drawings provided on this sheet are for illustration only. Cantrio Koncepts will not be held responsible for cutouts made without the actual product or product template.

Dimensions may vary within industry standard tolerances. Cantrio Koncepts reserves the right to make changes without notice.