

ASSEMBLY INSTRUCTION

ITEM#: BAS2236 SERIES

Important Safety Instructions:



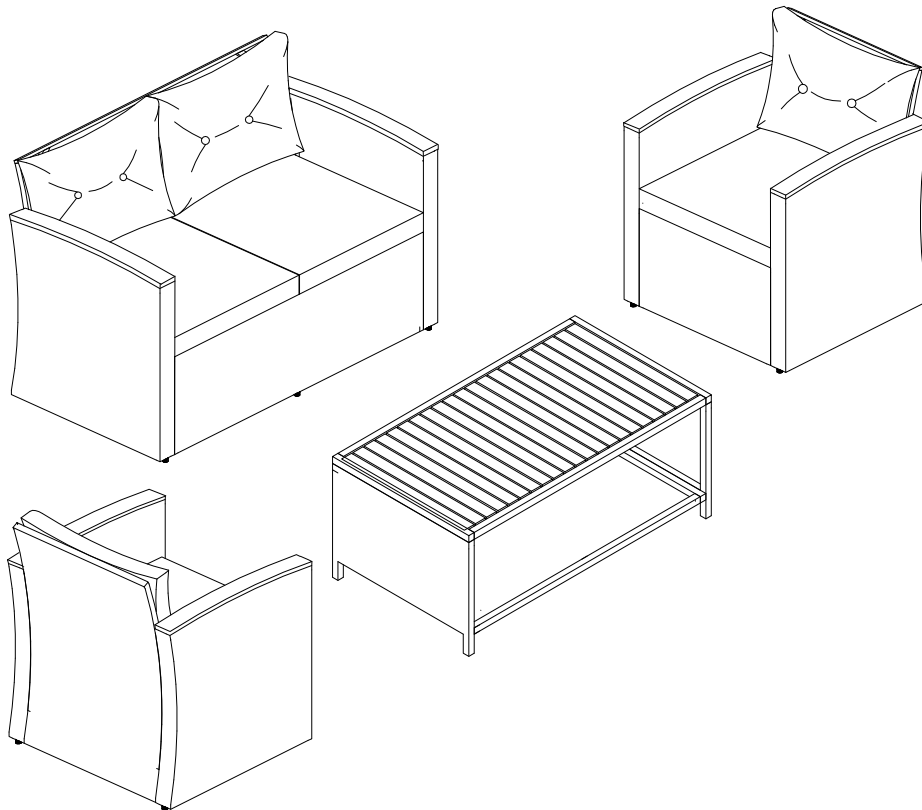

- **Please read all instructions before beginning assembly**
- **Please make sure receive all the parcels to start the assembly**
- **For your safety and convenience, assembly by two people is recommended**
- **Use the parts and hardware lists to identify and separate each of the components included**
- **Save all packing materials until assembly is completed to avoid the accidental discarding of smaller parts or hardware**

Note: You may find cushions placed underneath the table or between frames!



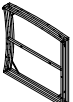
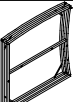

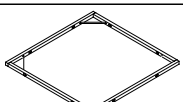
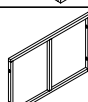
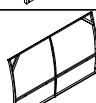
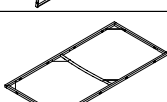
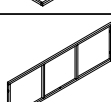
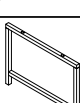
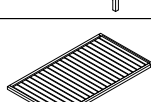
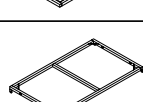
THANK YOU FOR PURCHASING

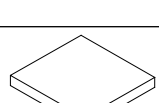
PARTS LIST

A	LEFT ARMREST	3PCS	
B	RIGHT ARMREST	3PCS	
C	CHAIR BACKREST	2PCS	
D	CHAIR SEAT PANEL	2PCS	
E	CHAIR FRONT PANEL	2PCS	
F	LOVESEAT BACKREST	1PCS	
G	LOVESEAT SEAT PANEL	1PCS	
H	LOVESEAT FRONT PANEL	1PCS	
I	TABLE SIDE LEG	2PCS	
J	TABLE TOP FRAME	1PCS	
K	UNDER TABLE	1PCS	
L	BACK CUSHION	4PCS	
M	SEAT CUSHION	4PCS	

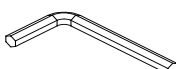
HARDWARE LIST

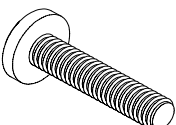
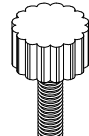
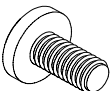
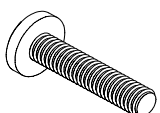
					
1 Allen Wrench - 1pcs	2 Washer - 64+1pcs	3 Bolt (M6*35mm) - 56+1pcs	4 Foot leveler - 13+1pcs	5 Bolt (M6*15mm) - 4pcs	6 Bolt (M6*25mm) - 4pcs

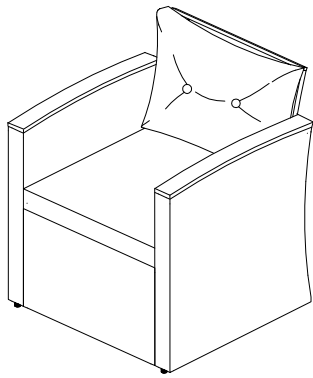

Single Chair x2

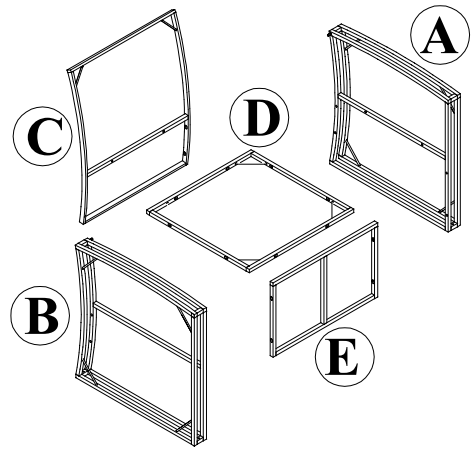

Note : Do not tighten bolts until all parts are connected

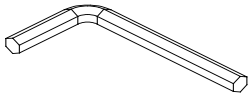

Allen Wrench - 1pcs



Washer - 32pcs

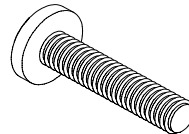

Bolt (M6*35mm) - x32pcs

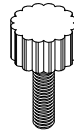

Foot leveler - 8pcs

Step 1:

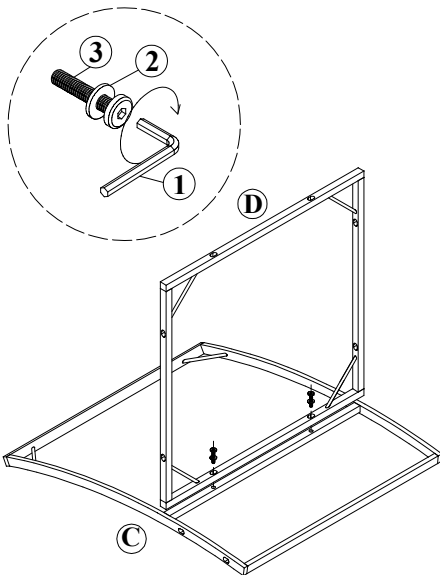

Step 2:

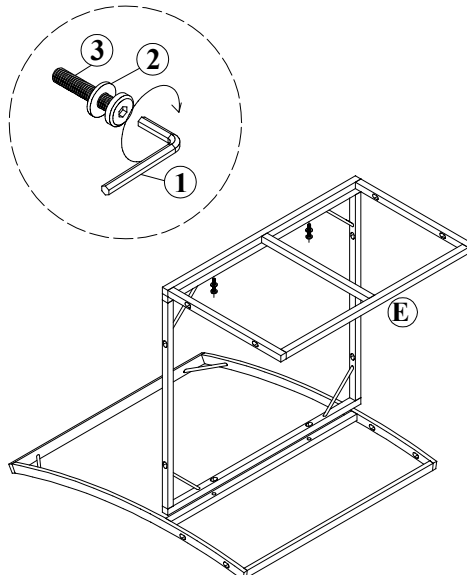

Step 3:

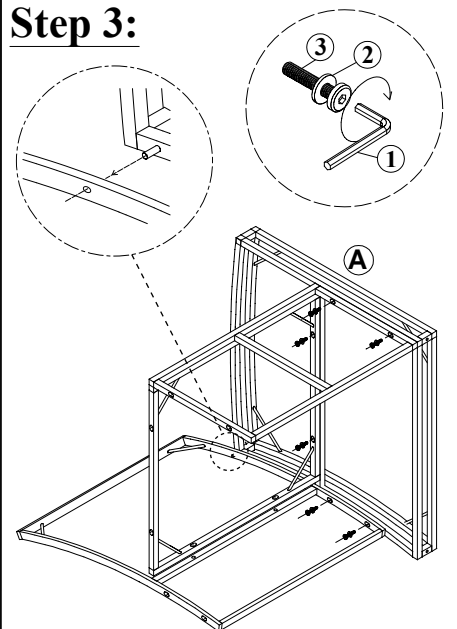

Step 4:

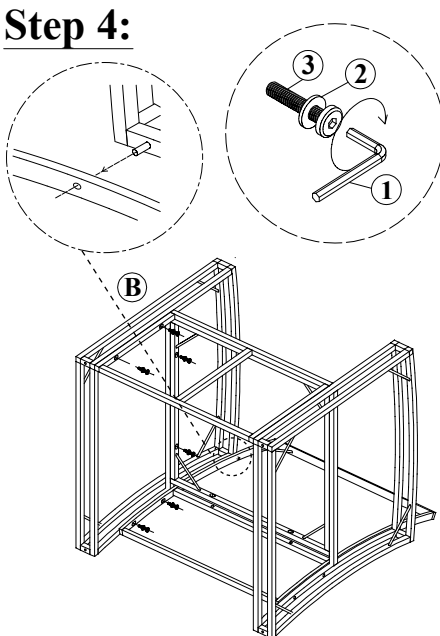

Step 5:

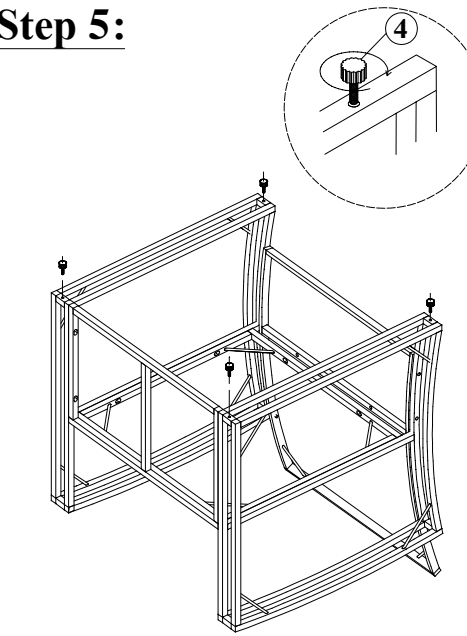

Finish:

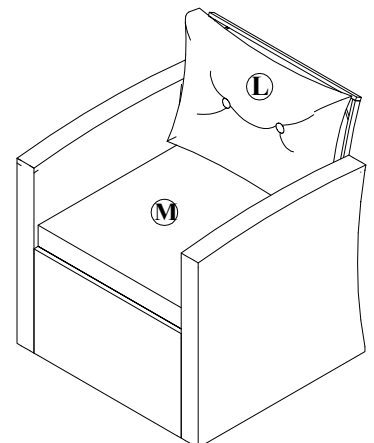

Tight all bolts unit when all parts are connected

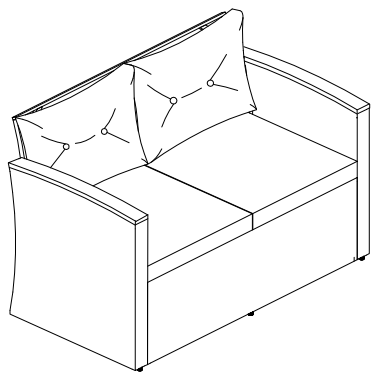

Love Seat x1

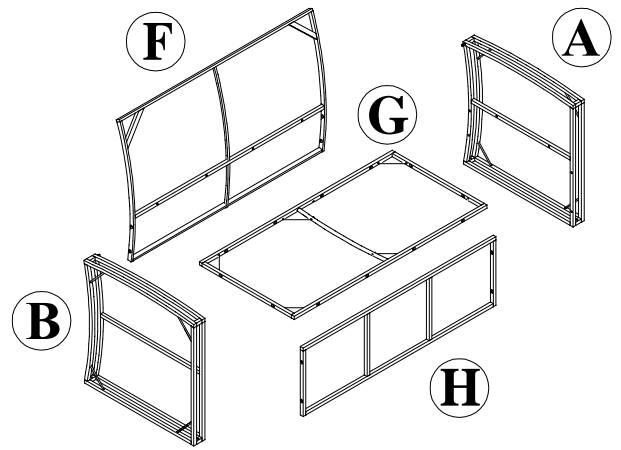

Note : Do not tighten bolts until all parts are connected

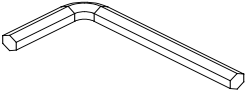
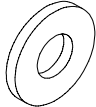
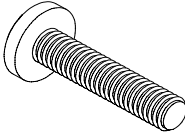
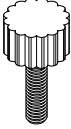
 <p>Allen Wrench - 1pcs</p>	 <p>Washer - 20pcs</p>	 <p>Bolt (M6*35mm) - x20pcs</p>	 <p>Foot leveler - 5pcs</p>
--	---	---	--

Step 1:

Step 2:

Step 3:

Step 4:

Step 5:

Finish:

Tight all bolts unit when all parts are connected

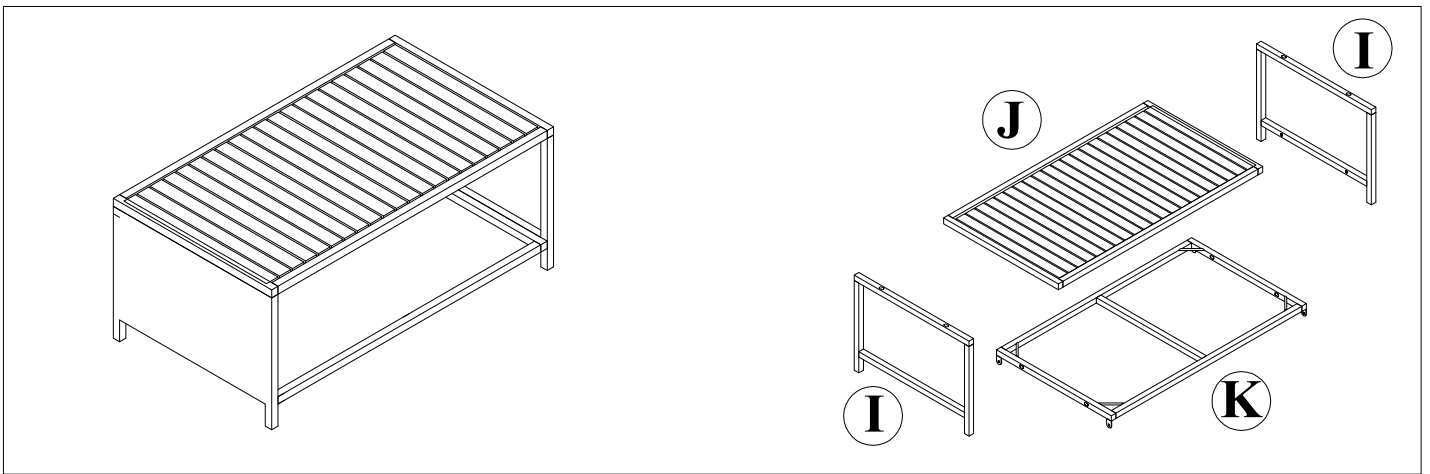

Note : Do not tighten bolts until all parts are connected

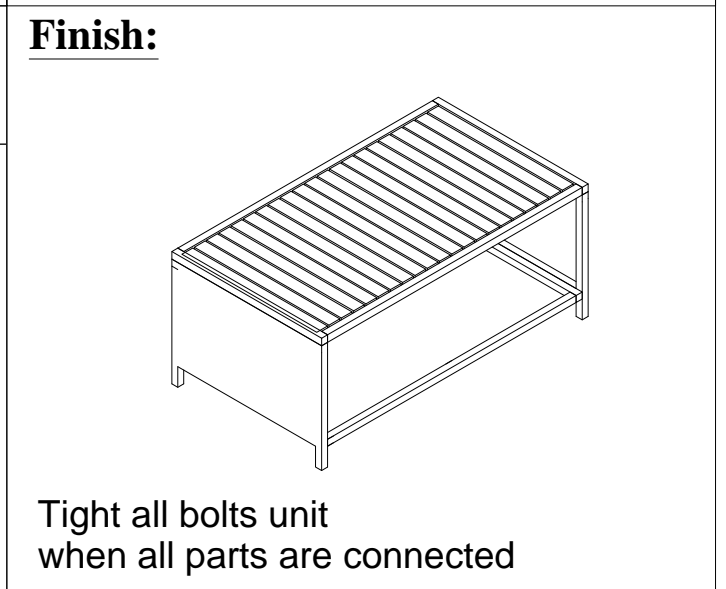
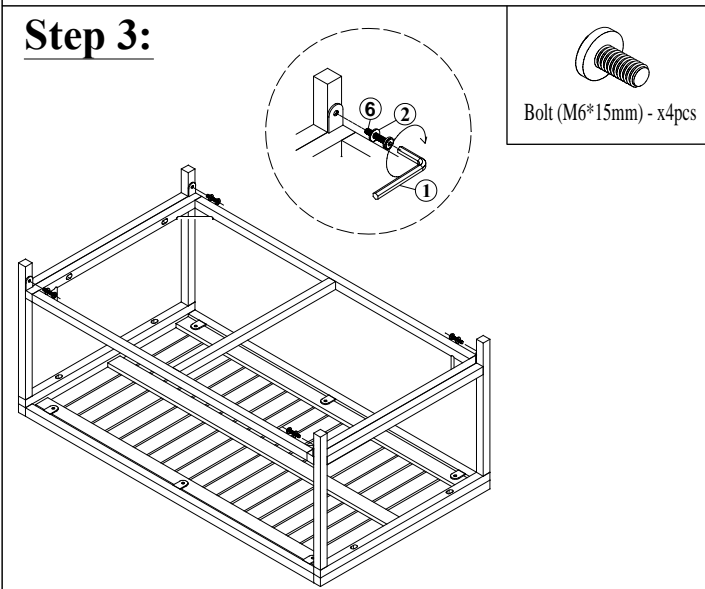
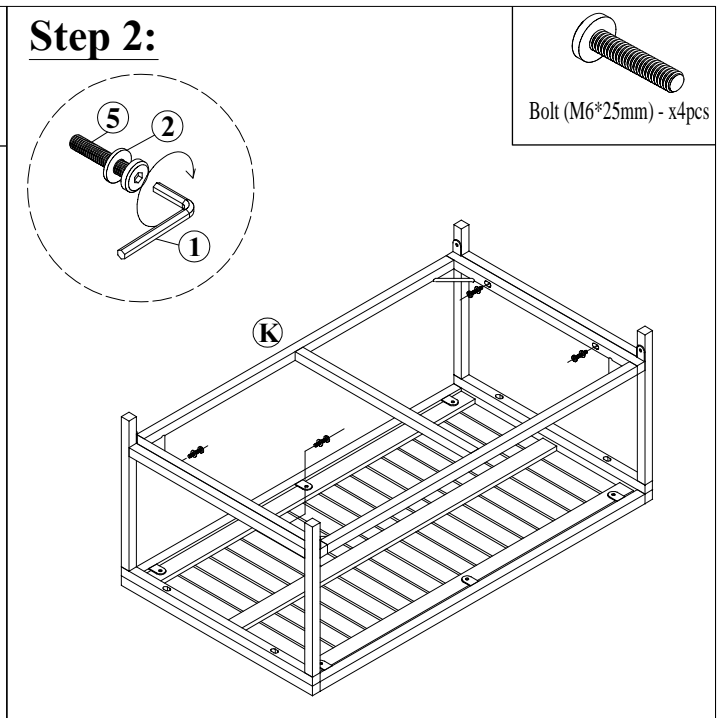
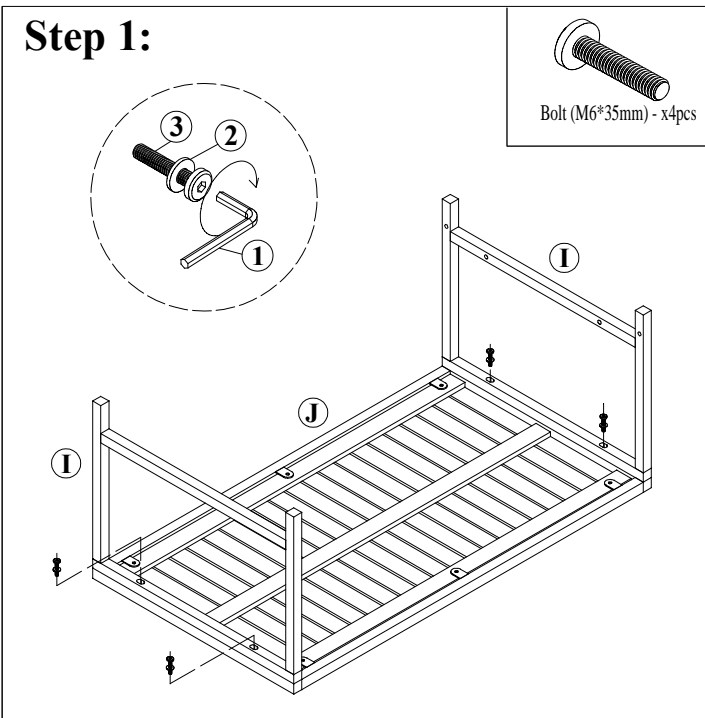
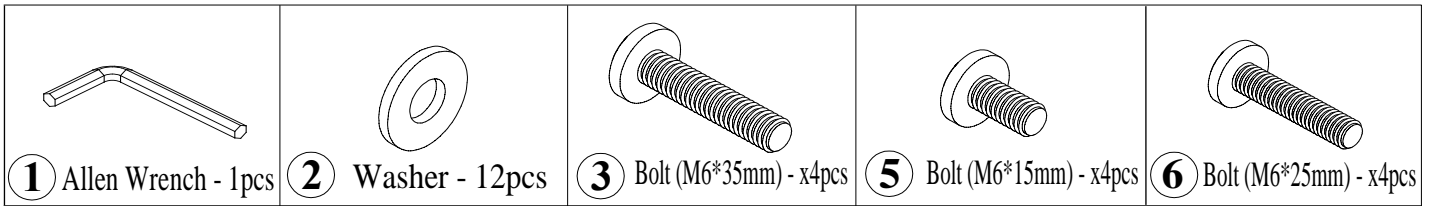



Bestsign International Inc.

421 N. Baldwin Park Blvd,
City of Industry, CA 91746
Tel:1-909-274-7615

E-mail:
service@bestsignintl.com

Furniture Care & Cleaning Instruction

- Do not expose the furniture to strong sunlight, which causes discoloration and shortens the product lifetime.
- Do not expose the furniture to extreme heat, cold, or humidity, which may cause wood to swell or warp.
- Do not leave the furniture wet with beads of water standing on the furniture.
- Wipe-spills with a clean dry cloth. Do not use chemicals or abrasives for cleaning!
- TAKE NOTE: THE BOLTS MAY SLIGHTLY LOOSEN OVER TIME. IF YOUR FURNITURE FEELS "WOBBLY" OR LOOSE, PLEASE RE-TIGHTEN BOLTS.

Wood Furniture Care & Cleaning Instruction

- To maintain the quality of your wood furniture, do not expose it to direct sunlight or excessive temperatures, extreme changes in humidity can cause warping.
- Better use coasters, pads, cloth or felt to protect the furniture surface. Use protective mats under hot dishes. Use a protective pad when writing with a pen.
- Lift objects rather than dragging them over the furniture surface.
- Blot spills immediately with a clean cloth. Dust often using a soft, clean, lint-free cloth. Avoid harsh fabrics, paper towels or disposable dusting towels as they may scratch the surface.
- Use a non-silicone and non-wax polish, do not use soap, water or wax.

Outdoor Furniture Cushions

Extend the life of your cushions by keeping them free of dirt and foliage. Periodically shaking or rinsing the cushions is recommended. Thoroughly flush using a hose with cold water to remove all soil and residue. For deeper cleaning, spot clean with mild soap. Do not machine wash or use chlorine bleach. Stand cushions on end and dry completely in the sun before using or storing. Do not place in dryer. To prevent mildew, never wrap in plastic for storage and ensure the cushion is completely dry before storing. Store indoors when not in use for long periods of time or during inclement weather.

Furniture Warranty

CUSHION AND WOOD COMPONENT

Limited 90 days warranty from date of delivery against manufacturer defects or excessive deformity of cushions and components under normal use and conditions. Replacements and repairs will be in the original color and style, if available; a similar color and style will be offered if the original has been discontinued.

Important Limitations

- Please note that our warranties do not cover failure due to:
 1. Any modifications to the original structure of the product/Accidental damage/Abuse/Misuse/Commercial Use.
 2. The wear and tear caused by daily use, including: fading, scratching or chipping.
- Any defects Parts or missing parts must be reported within the 30 days of receipt of the item otherwise it would be out of our 90 days warranty term.

What is Proposition 65?

Proposition 65 is a California law that requires warning labels on products that may contain one of more than 800-plus chemicals or ingredients that the California Office of Environmental Health Hazard Assessment(OEHHA) has deemed to cause cancer or other reproductive toxicity. Chemicals and elements on this list include wood dust , brass , and other everyday substances, which can be found in very common household items, such as : lamps , tableware , jewelry , crystal glasses , electric cords , beauty products , automobiles , and furniture.

Why Did I Find a Proposition 65 Warning on My Home Goods Product?

We include Proposition 65 warnings on all of our products because there is always a chance that one of the 800-plus common chemicals and ingredients listed under this law could potentially be on our furniture or packing materials. We risk large fines under this law , if we don't include this warning.

Should I worry?

We realize you may be worried finding this warning on our products , but we want to reassure you that the hazardous exposure limits for any of these chemicals have never been found on furniture products that we've shipped to our customers. Additionally, this warning label is very common and can be found on almost every piece of furniture sold in the state of California.

Just How Common Are Proposition 65 Warnings?

Proposition 65 warnings have become so common in California that it is hard to take a trip to local bank, grocery store , or restaurant without finding at least one warning. In fact, even the Disney Land Resort has a Proposition 65 warning:

