

Hiro

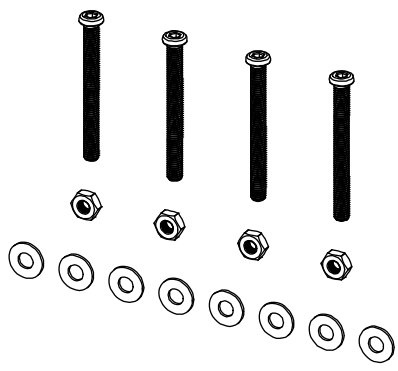

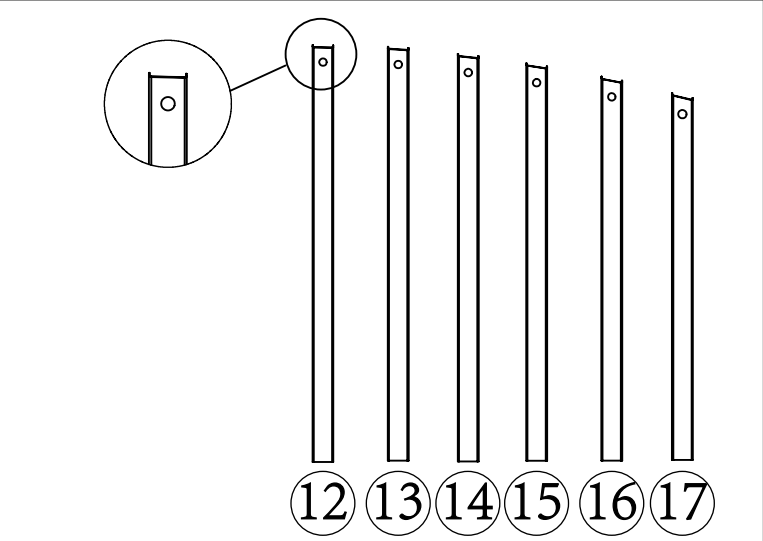

Before installation, first distinguish No. 6 - 11 and 12 - 17 according to the shape of the holes, and arrange them from left to right as shown in the figure. After confirmation, install them in sequence.

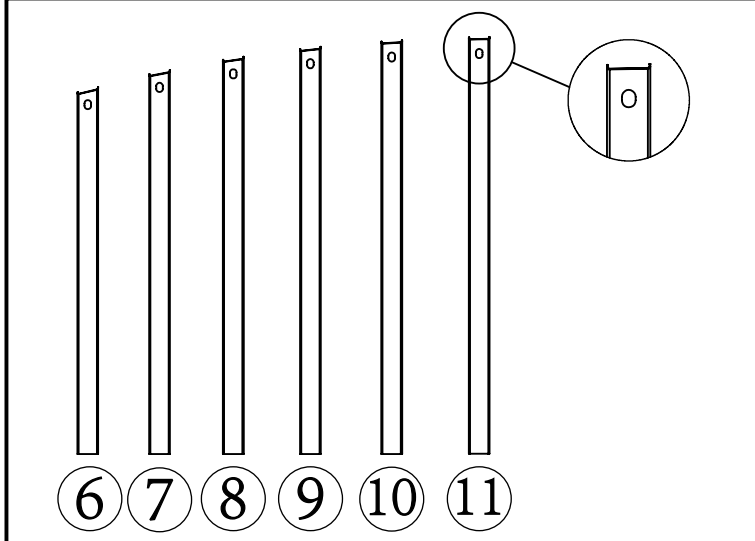
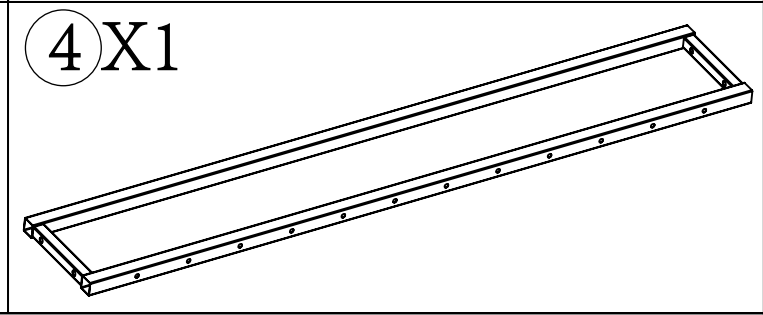
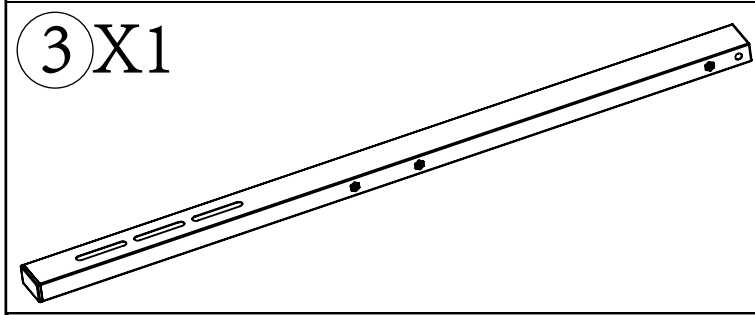
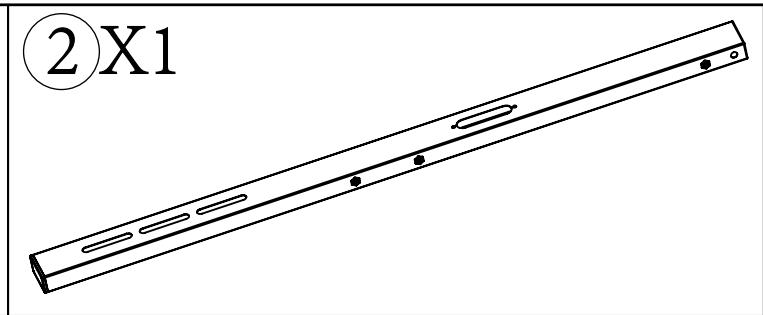
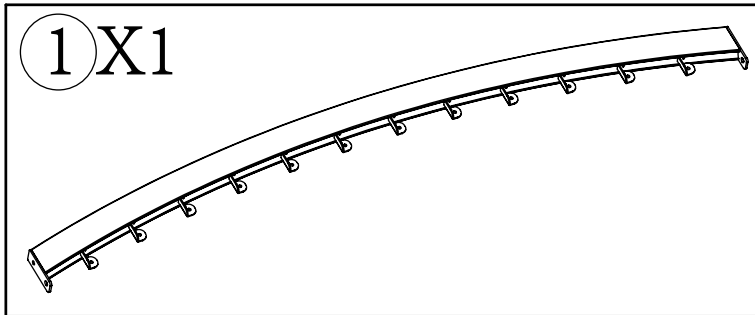
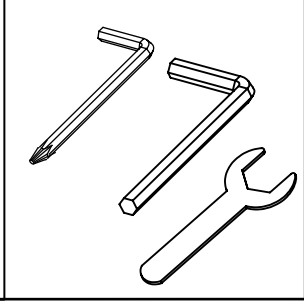
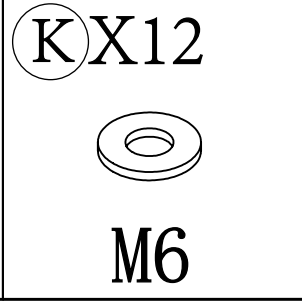
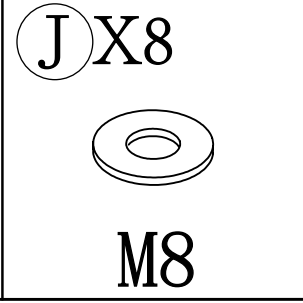
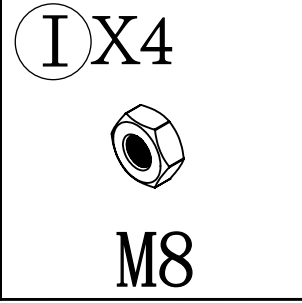
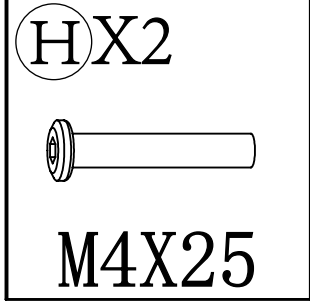
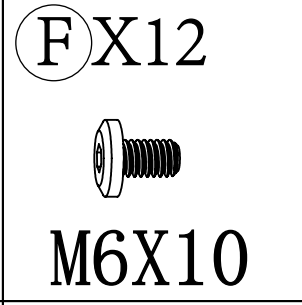
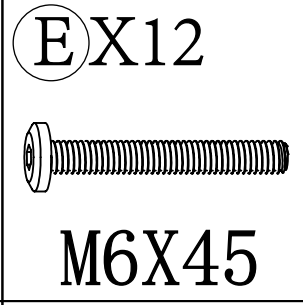
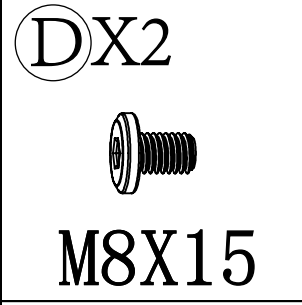
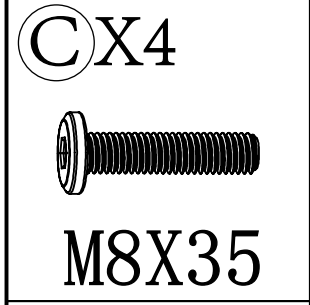
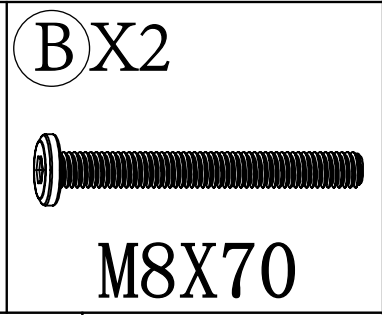
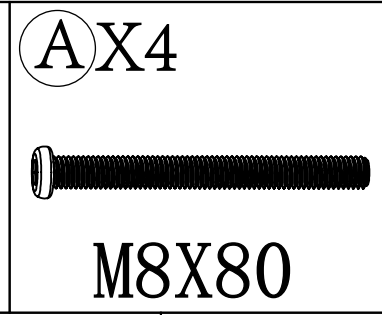
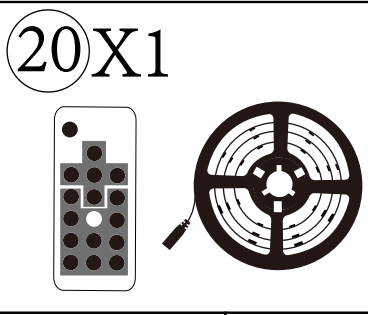
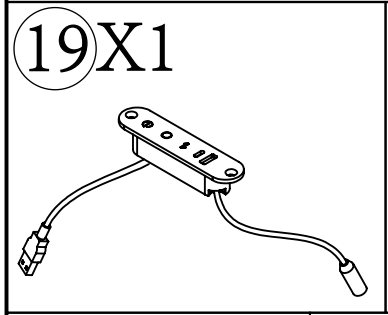

# Difference screws display (1:1)

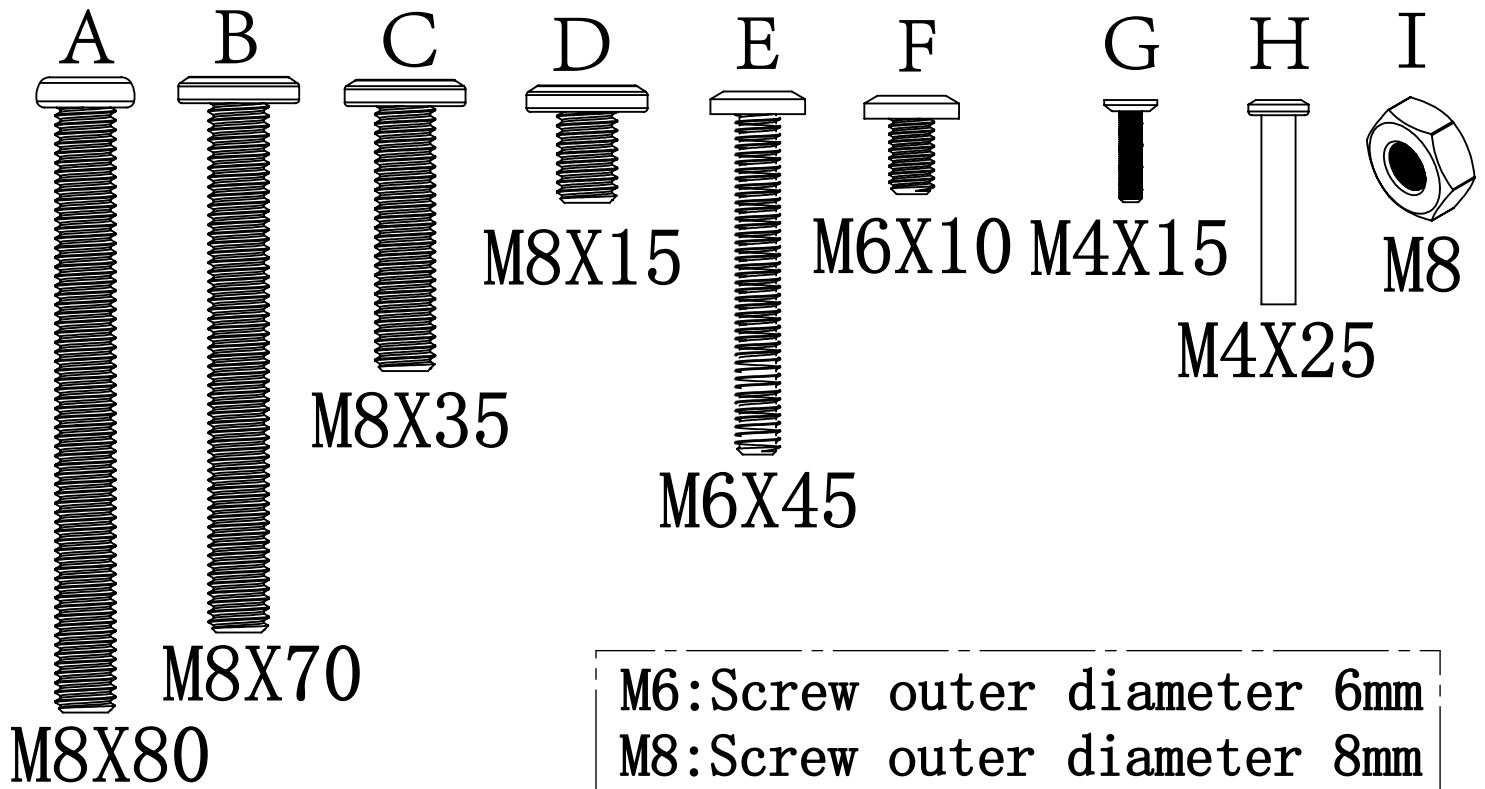

M6: Screw outer diameter 6mm  
 M8: Screw outer diameter 8mm  
 M4: Screw outer diameter 4mm

## Step 1

B	M8X70	2
D	M8X12	2

Please do not tighten the screws for now

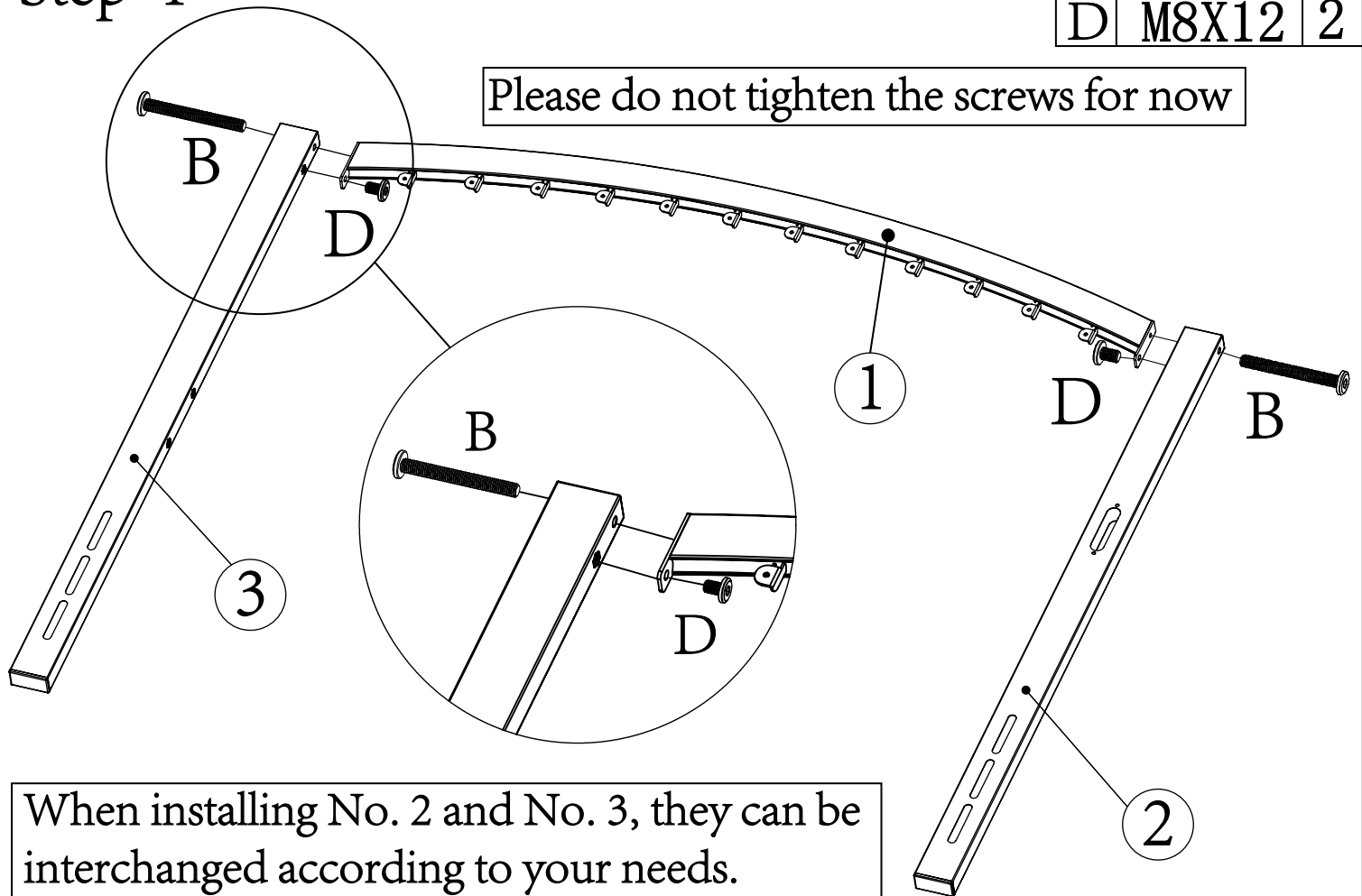

When installing No. 2 and No. 3, they can be interchanged according to your needs.

# Step 2

F	M6X10	12
K	M6	12

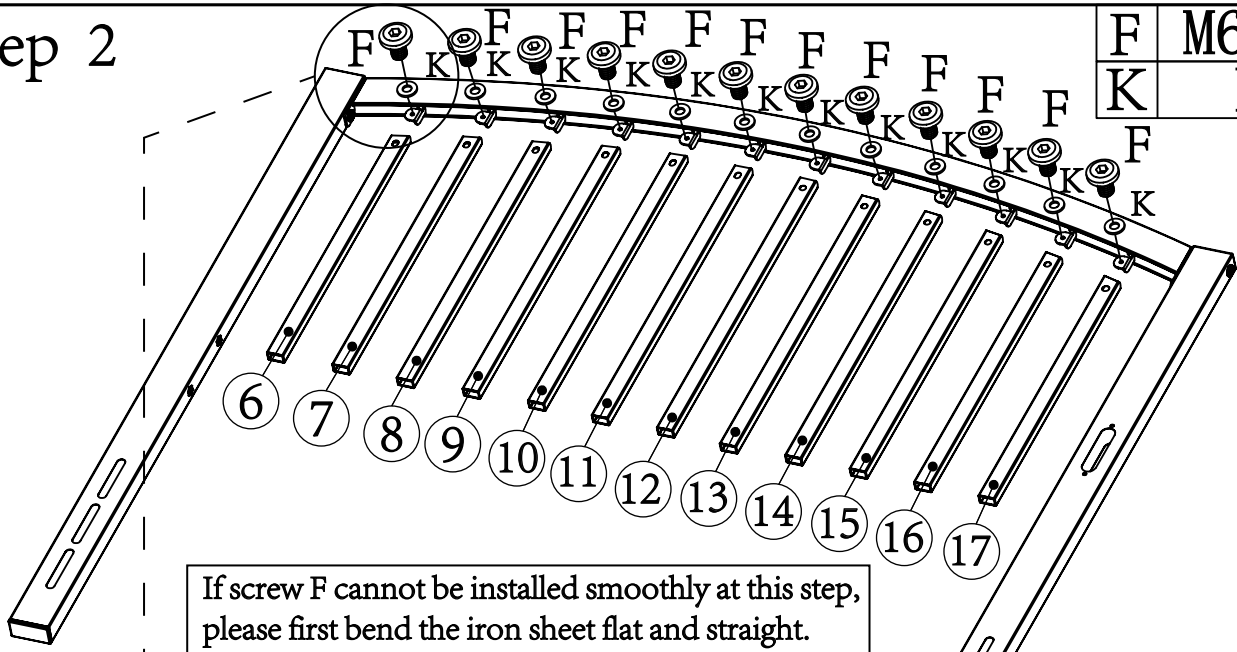

If screw F cannot be installed smoothly at this step, please first bend the iron sheet flat and straight.

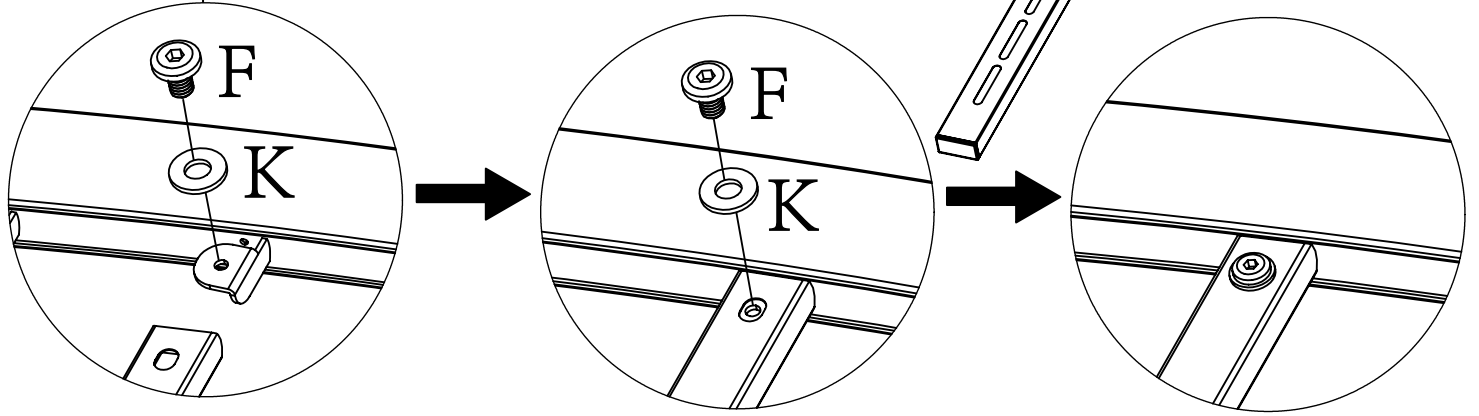

# Step 3

C	M8X35	4
---	-------	---

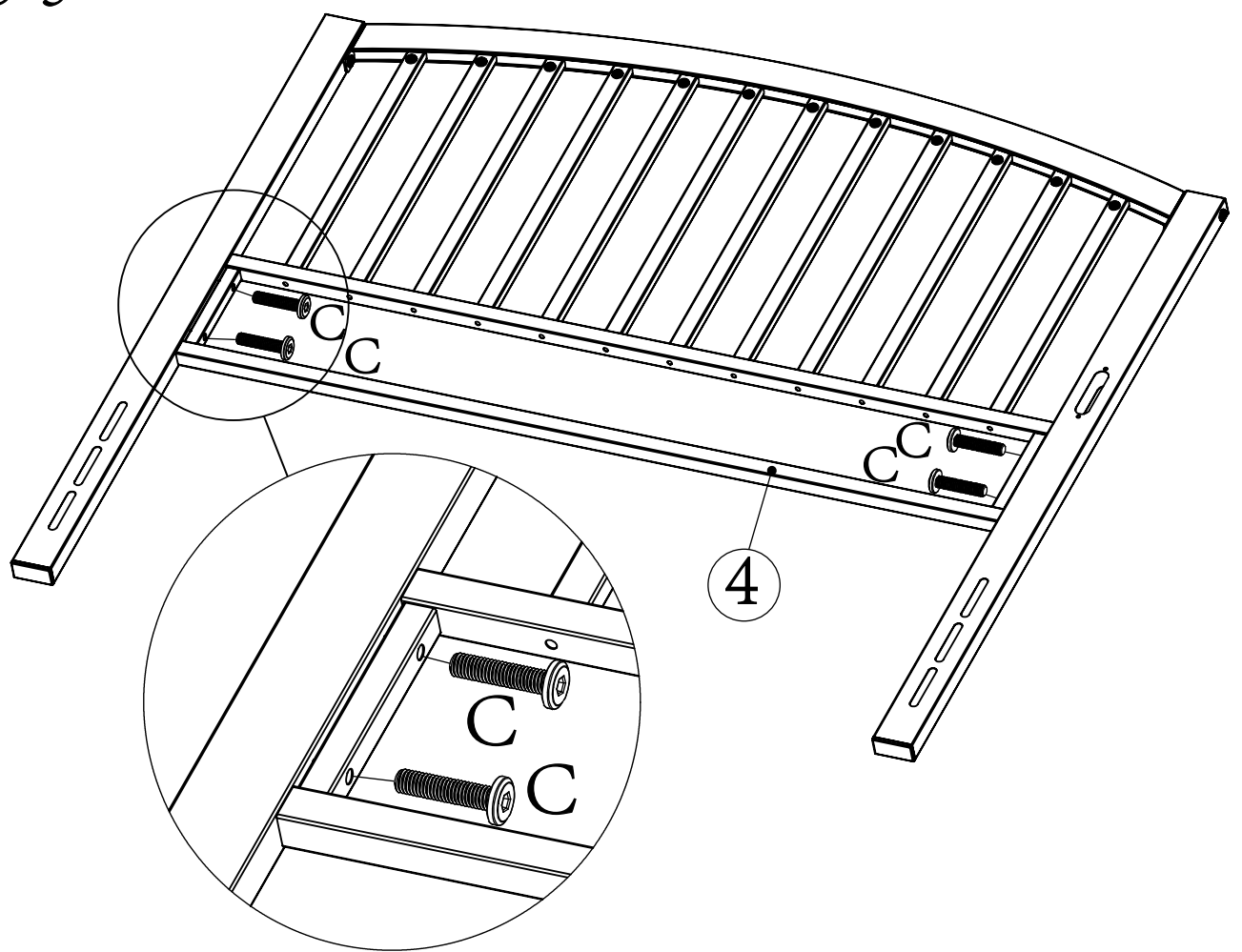

# Step 4

E	M6X45	12
---	-------	----

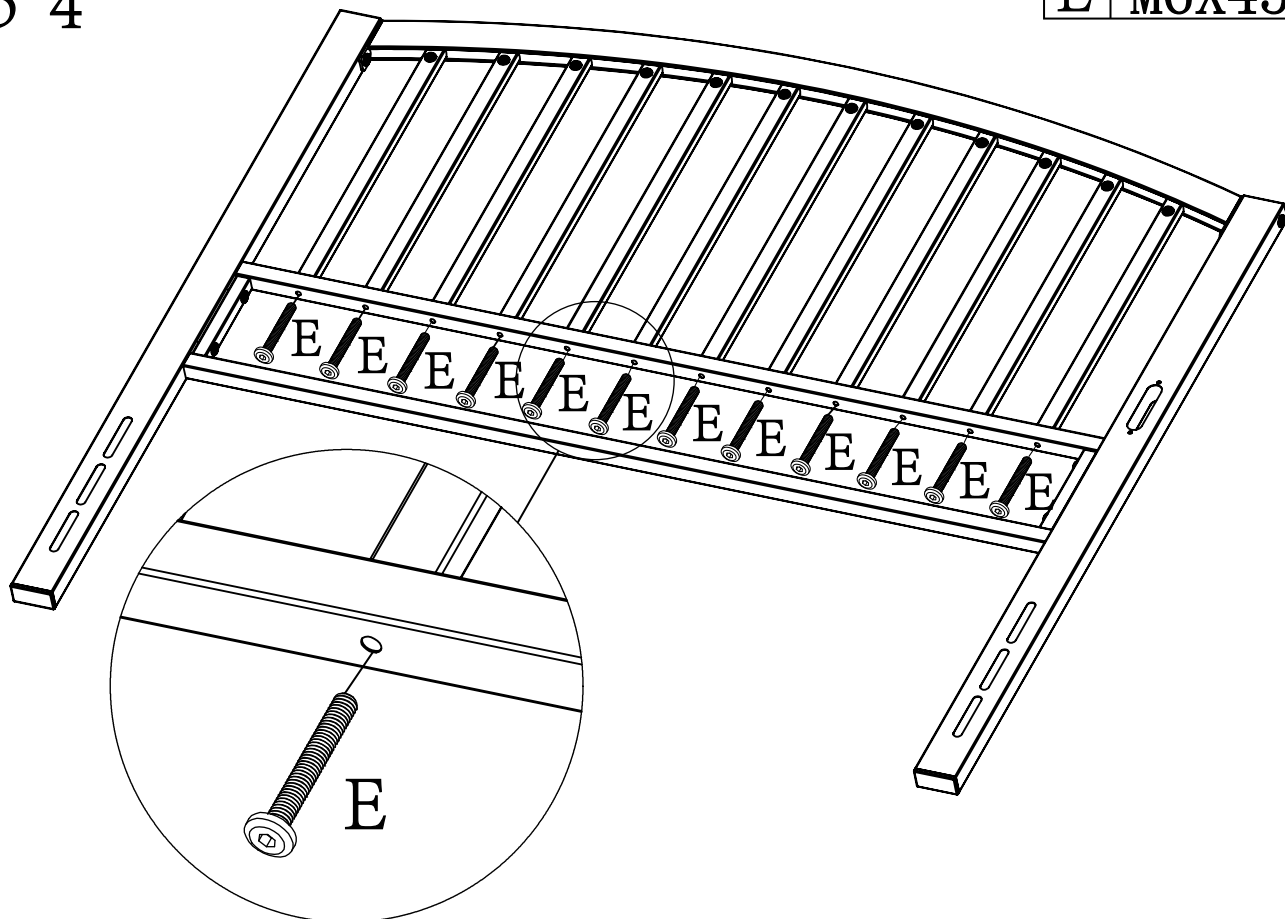

After assembling the E - screws, please tighten the screws from the previous

# Step 5

G	M4X15	2
H	M4X25	2

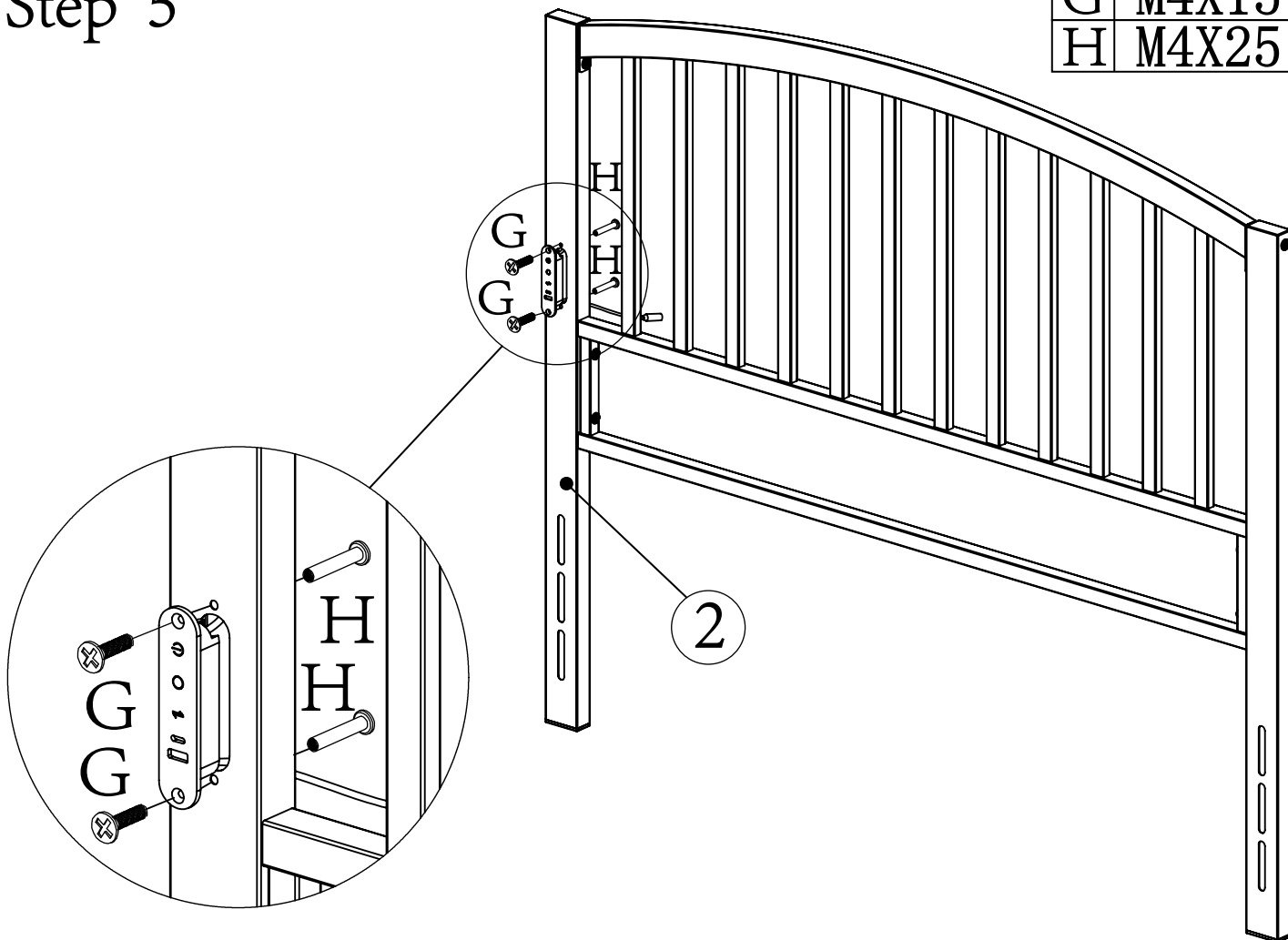

# Step 6

Please connect the socket properly first and then paste the light strip.

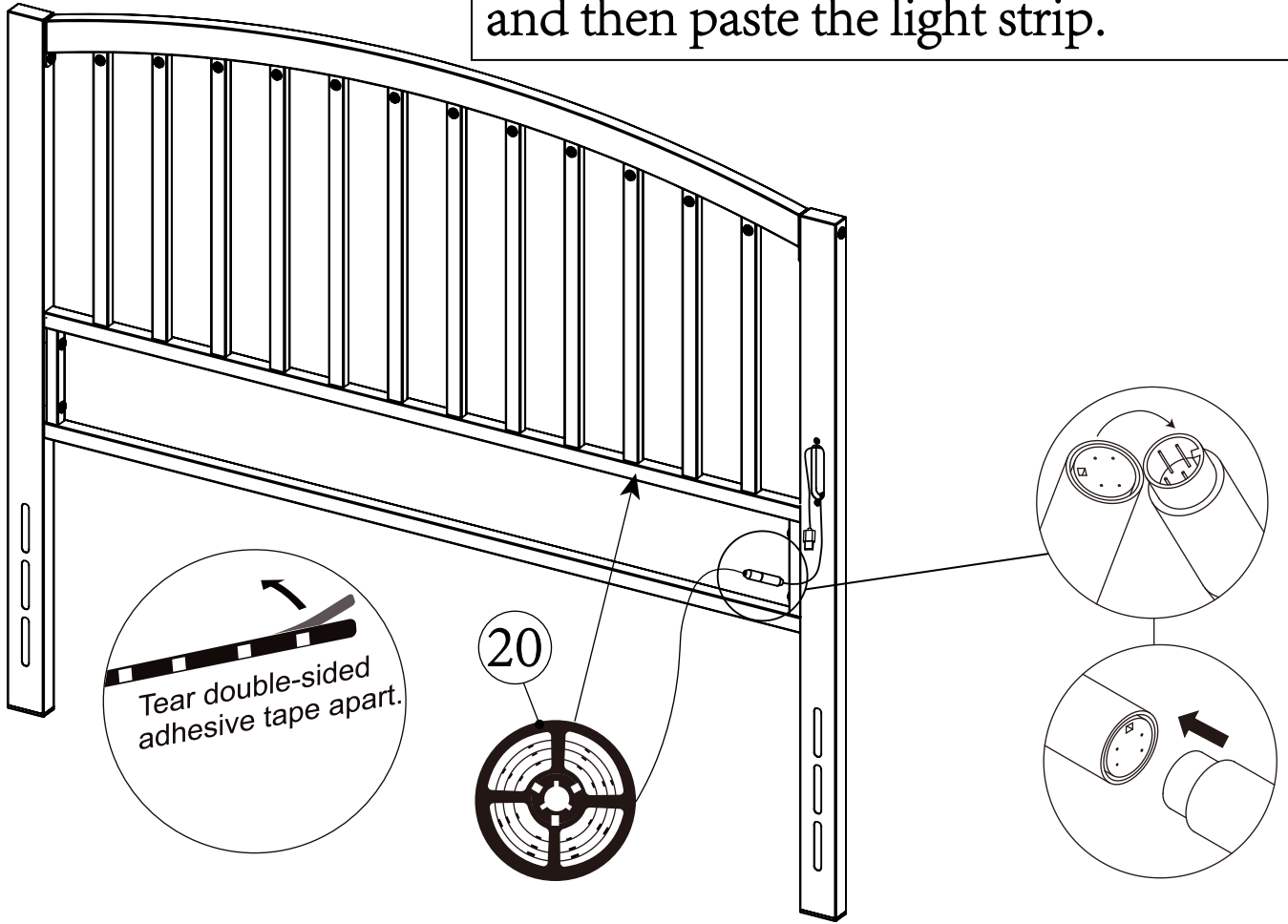

# Step 7

A	M8X80	4
I	M8	4
J	M8	8

