









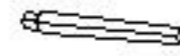

CARE AND MAINTENANCE

Wipe clean with a soft, dry cloth. The seat board can be cleaned with a mild cleaner. Test the cleaning method on a hidden area before using them over the entire area.

NOTICE

- * Please make sure that you have all parts indicated before you begin assembly of this item.
- * This item should be assembled on a soft surface to prevent scratching the finish during assembly.
- * This item may require periodic tightening.
- * Do not tighten bolts until completely assembled.

Part List and Hardware List

Piece	Description	Picture	Quantity
A	CHAIR BACK		1 X
B	SEAT CUSHION		1 X
C	L/FRONT LEG		1 X
D	R/FRONT LEG		1 X
E	L/STRETCHER		1 X
F	R/STRETCHER		1 X
G	FRONT STRETCHER		1 X
H1	BOLT $\phi 5/16$ "*2"		5 X
H2	BOLT $\phi 5/16$ "*3-1/2"		4 X
H3	L-WRENCH		1 X
H4	SCREW		6 X

Product Dimensions: 19"W*20"D*44"H

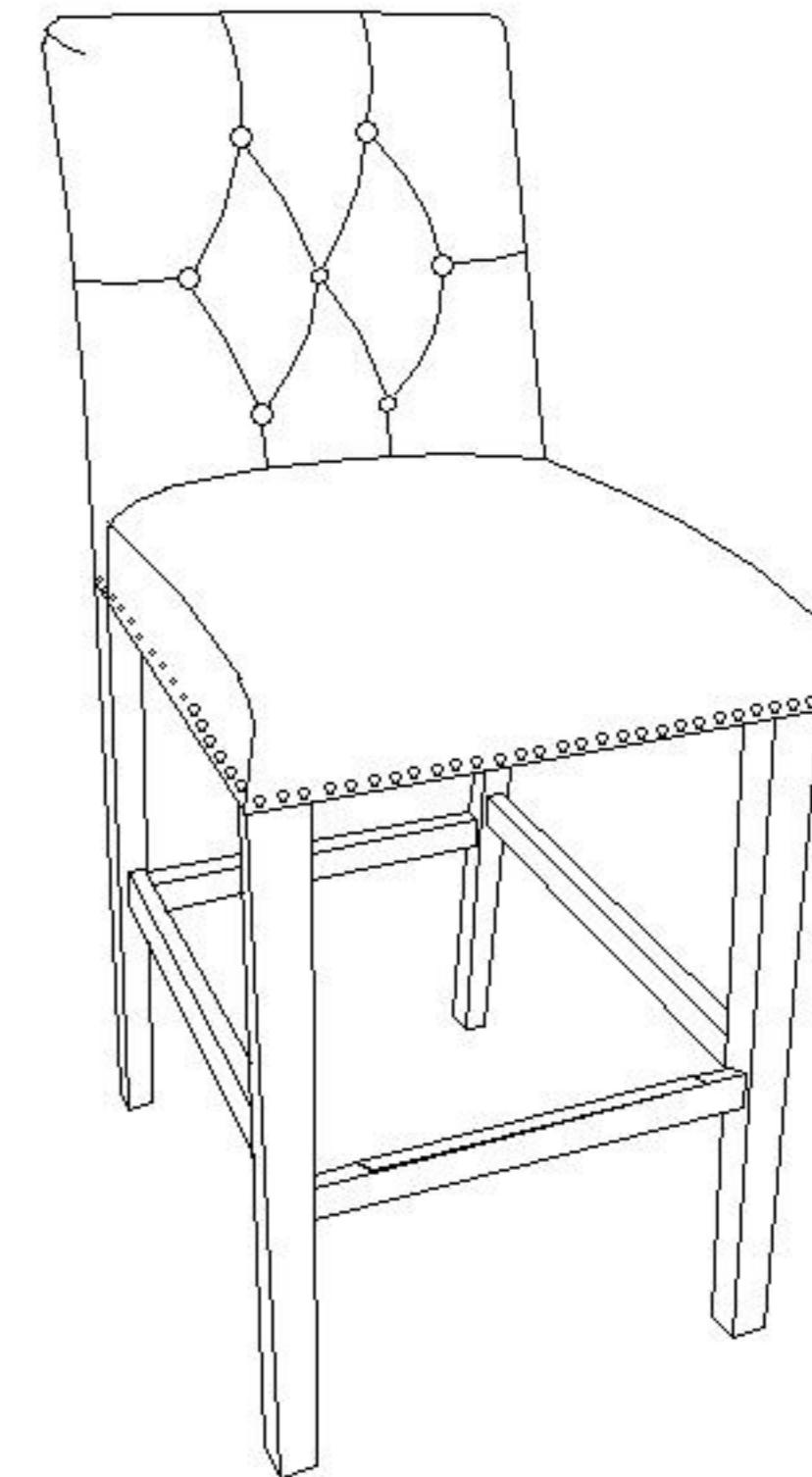

PREPARATION

Before beginning assembly of product, make sure all parts are present. Compare parts with package contents list and hardware contents list. If any part is missing or damaged, do not attempt to assemble the product.

Estimated Assembly Time:7 minutes.

Tools Required for Assembly (included):Wrench.

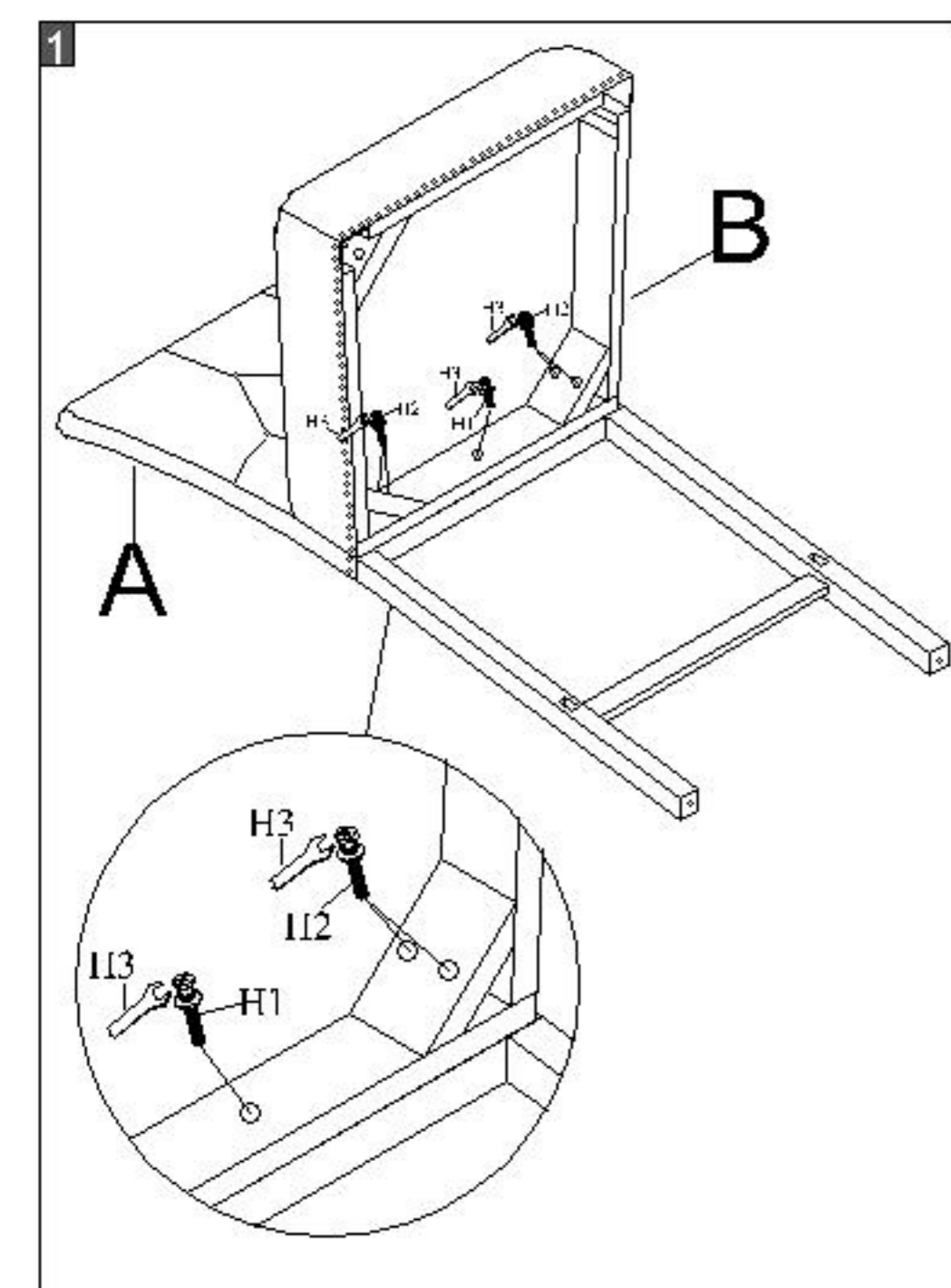

Step 1:
Assemble seat cushion (B) with chair back (A). Using L-wrench (H3) to lock with 5*bolts (1*H1 & 4*H2).

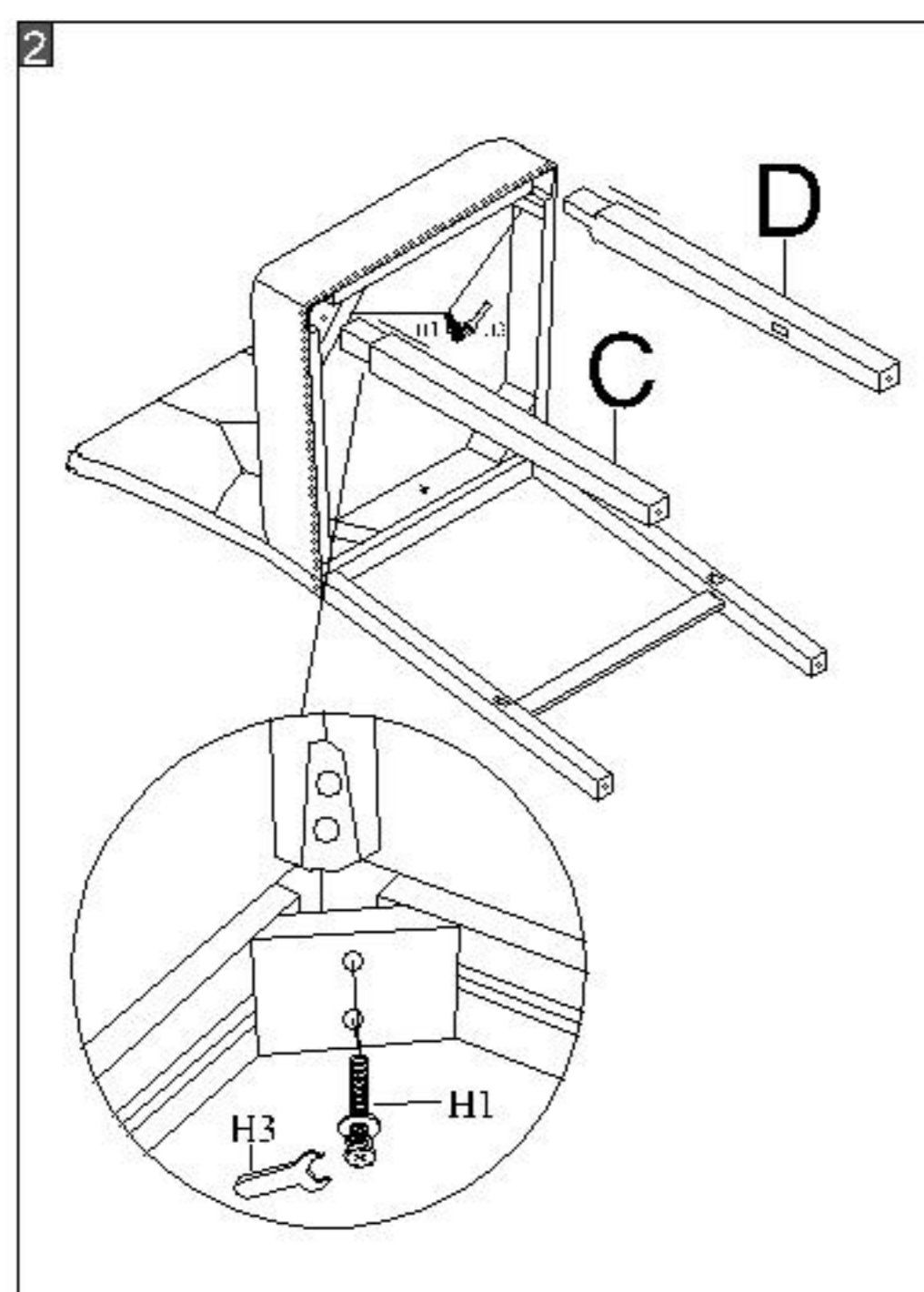

Step 2:
Assemble front legs (C & D) with seat cushion (B). Using L-wrench (H3) to lock with 4*bolts(H1).

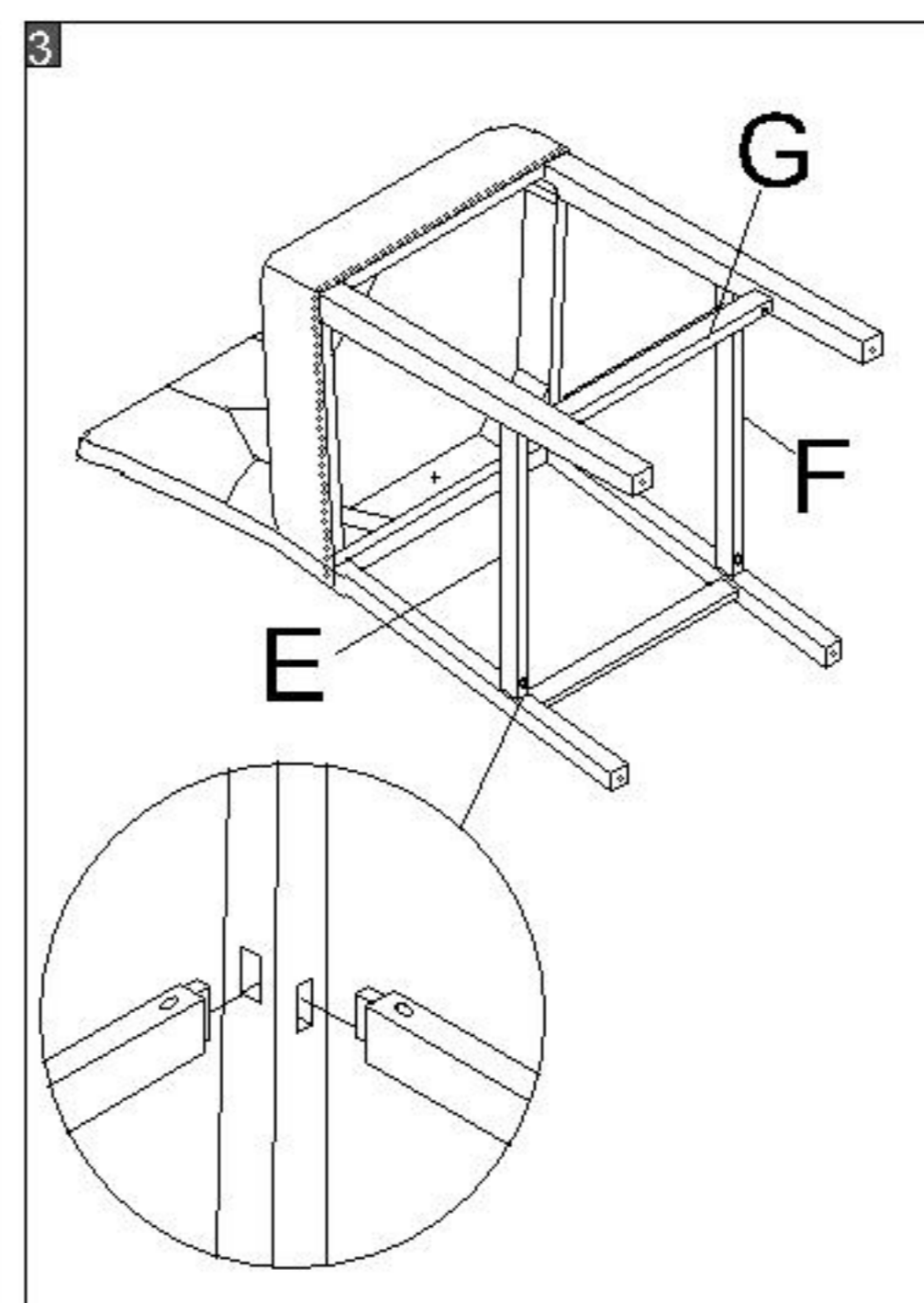

Step 3:
Assemble 3 stretchers (E · F & G) with the front and back legs.

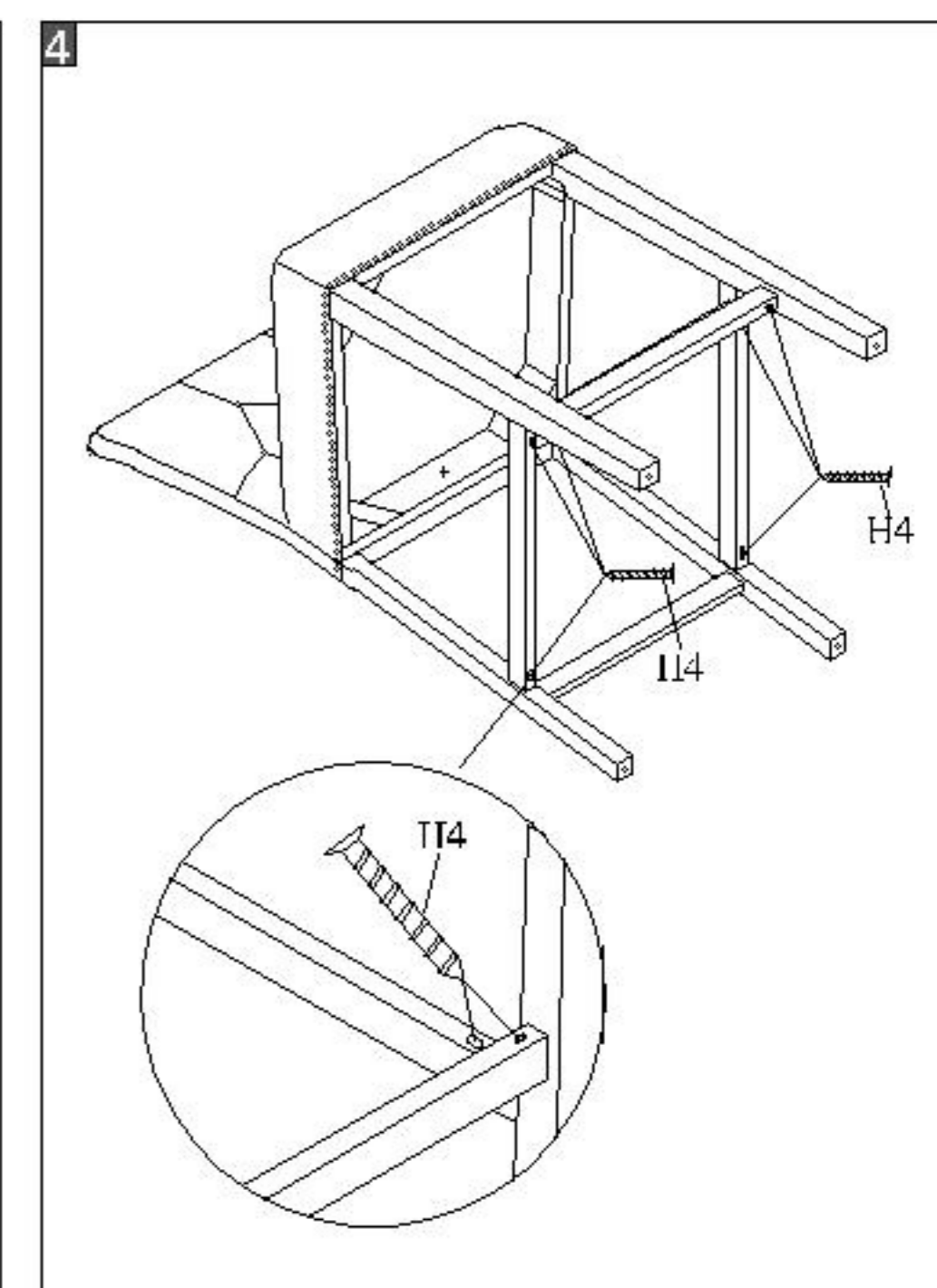

Step 4:
Lock the stretchers tight with legs by using 6*screws (H4).