

Assembly Instructions
Instrucciones De Ensamblaje
Instructions D'Assemblage



877-472-4296

www.medalsports.com

LIMITED 90 DAYS WARRANTY

This product is covered by a limited warranty that is effective for 90 days from the date of purchase. If, during the limited warranty period, a part is found to be defective or breaks, we will offer replacement parts at no cost to you, the customer. The only exceptions to the warranty include mainframes, table tops, playing surfaces, batteries or tools.

The above warranty will not apply in cases of damages due to improper usage, alteration, misuse, abuse, accidental damage or neglect.

This Limited Warranty gives you specific legal rights and you may also have other rights vary from one State (province) to another.

A PURCHASE RECEIPT (or other proof of purchase) will be required before any warranty service is initiated. For all requests for warranty service, please feel free to contact our Consumer Service Department.

Please be aware of your product's Limited Warranty for the return/refund policy from the store. We, at Medal Sports, cannot handle the product which is out of product's limited warranty since we only provide available parts. Thank you!

PLEASE CONTACT US BEFORE RETURNING THE PRODUCT TO THE STORE!

GARANTIE LIMITEE DE 90 JOURS

Este producto está cubierto por una garantía efectiva de 90 días a partir de la fecha de su compra. Durante el período límite de la garantía, si una parte defectuosa o quebrada es encontrada, nosotros ofreceremos una reparación o un reemplazo de la partes sin ningún costo para ud, nuestro cliente. Las únicas excepciones de la garantía incluyen unidad principales, tableros de mesa, superficies, pilas o herramientas.

La susodicha garantía no se aplicará en los casos de daños y perjuicios debido al uso impropio, la alteración, el mal uso, el abuso, el daño accidental o la negligencia.

Esta garantía limitada le da a usted derechos legales específicos, usted también puede tener otros derechos que varían de un estado (provincia) a otro.

EL RECIBO DE LA COMPRA (U otra prueba de compra) sería requerida antes que cualquier servicio de garantía fuera iniciada. Para todo pedido por servicio de garantía, por favor siéntase libre de ponerse en contacto con nuestro Departamento de Servicio de Consumidor.

Por favor tenga atención sobre el Límite de Garantía de su producto de la política de vuelta/reembolsa desde la tienda. Nosotros, Medal Sports, no podemos manejar el producto que está fuera del límite de garantía ya que proporcionamos solamente partes disponibles. ¡Gracias!

¡POR FAVOR PÓNGASE EN CONTACTO CON NOSOTROS ANTES DE DEVOLVER EL PRODUCTO A LA TIENDA!

GARANTÍA LIMITA DE 90 DIAS

Ce produit est couvert par une garantie limitée valable 90 jours à compter de la date d'achat. Si pendant cette période une pièce est jugée défectueuse ou se casse, nous la remplacerons gratuitement. Les seules exceptions à la garantie comprennent les armatures principales, les dessus de table, les surfaces de jeu, les piles ou les outils.

La garantie ci-dessus ne s'applique pas en cas de dommages occasionnés par une mauvaise utilisation, une altération du produit, de mauvais traitements, des dommages accidentels ou des négligences.

Cette garantie limitée vous accorde des droits légaux spécifiques ainsi que d'autres droits variant d'un état (province) à un autre.

UNE FACTURE D'ACHAT (ou toute autre preuve d'achat) sera exigée avant toute intervention sous garantie. Pour toute demande d'intervention sous garantie, veuillez contacter notre Service à la Clientèle.

Comprenez notre garantie produit limitée en ce qui concerne notre politique de retour/remboursement depuis votre magasin. Ici à Medal Sports, nous ne pouvons prendre un compte un produit qui n'est plus sous garantie puisque nous ne pouvons que fournir les pièces disponibles. Remerciements!

VEUILLEZ NOUS CONTACTER AVANT DE RETOURNER LE PRODUIT EN MAGASIN!



WE ARE READY TO HELP

DO NOT RETURN TO STORE

ESTAMOS LISTOS PARA AYUDAR

NO DEVOLVERLO A LA TIENDA

NOUS SOMMES PRÊTS À VOUS AIDER

NE PAS RAPPORTER EN MAGASIN

Please Contact

Por favor Contacto

Veillez contacter

MD SPORTS

Customer Service
Toll Free

Servicio al Cliente
Llamada Gratuita

Service Clientèle
Appel Gratuit

877-472-4296

Mon.-Fri.,
9:00 a.m. to 5:00 p.m. EST

Lunes a Viernes,
9:00 a.m. a 5:00 p.m. ET

Du lundi au vendredi de
9:00 a 17 heures HNE

For additional resources and
Frequently Asked Questions,
please visit us at

Por mayor información y
Preguntas Frecuentes, favor
visitarnos en

Pour toute information
complémentaire ou réponse
aux questions fréquentes,
veuillez vous rendre sur

www.medalsports.com

TOOLS REQUIRED

Phillips Screwdriver - **Not Included**
Standard (Flat Head) Screwdriver - **Not Included**
Allen Key - **Included**

HERRAMIENTAS NECESARIAS

Destornillador Phillips - **No incluido**
Destornillador de Cabeza Plana - **No incluido**
Llave Allen - **Incluido**

OUTILS REQUIS

Tournevis cruciforme - **Non inclus**
Tournevis standard (Tête plate) - **Non inclus**
Clé hexagonale - **Incluse**

**RECOMMENDED**

Electric Screwdrivers may be helpful during assembly; however, please set a low torque and use extreme caution.

**RECOMENDADO**

Los destornilladores eléctricos pueden ser de gran ayuda durante el ensamblado; sin embargo, por favor ajuste el par de giro bajo y sea extremadamente precavido.

**RECOMMANDÉ**

Un tournevis électrique peut être utile pour l'assemblage; utilisez cependant une vitesse de rotation lente et avec prudence.



Power Tools: **Set to Low Torque**
Herramientas eléctricas: **Establecer bajo par de torsión**
Visseuse électrique: **Couple faible**



High Torque Over Tightened
Alto par más estrictas
Un couple élevé peut créer des dommages

! IMPORTANT NOTICE

1. This product is intended for INDOOR use only.
2. Please do not sit, climb or lean on the product.
3. Please do not drag the product when moving it in order to avoid damaging the legs.
4. Please only use furniture polish spray to clean the exterior surfaces of the product.
5. This is not a children's toy, adult supervision is required for children playing this game.

AVISO IMPORTANTE

1. Este producto está destinado para el uso INTERIOR solamente.
2. Por favor no sientes, subas o inclínes el producto.
3. Por favor no arrastres el producto cuando está moviendo para evitar el daño sobre las piernas.
4. Por favor use solamente spray de pulido para muebles para limpiar la superficie exterior del producto.
5. Este no es un juguete para niños, se requieren la supervisión adulta para niños cuando esté jugando al juego.

NOTE IMPORTANTE !

1. Ce produit est conçu pour une utilisation en intérieur uniquement.
2. Veuillez ne pas vous asseoir, grimper ou vous appuyer sur la produit.
3. Veuillez ne pas déplacer la produit en la tirant pour ne pas endommager les pieds.
4. Veuillez utiliser seulement le vernis pour meuble pour nettoyer les surfaces extérieures du produit de jeu. Ce n'est pas un jeu d'enfant et la surveillance d'adultes est requise pour les enfants qui jouent ce jeu.
- 5.



At least 2 adults needed
Se necesitan al menos 2 adultos
Il faut au moins 2 adultes



No children in assembly area
No deben estar los niños en el area de ensamble
Pas d'enfants dans la zone d'assemblage



Keep away from pets in assembly area
Mantener alejados a los animales domesticos del area de ensamble
Tenir les animaux de compagnie à distance



Do not use or keep product outdoors. For indoor use only. No wet/humid conditions.
No usar o guardar el producto en el exterior. Solo para uso en interior. No utilizar ni guardar el producto en lugares humedos o mojados
N'utilisez ni ne stockez ce produit en extérieur. Uniquement pour utilisation en intérieur. Ne pas exposer à l'humidité

! WARNING

Adult assembly required.
CHOKING HAZARD - This item contains small parts and small balls. Not suitable for children under 3 years.

! ADVERTENCIA

El ensamblaje debe ser realizado por un adulto.
PELIGRO DE ASFIXIA - Este artículo contiene piezas pequeñas y pequeñas bolas. No es apto para niños menores de 3 años de edad.

! ATTENTION

L'assemblage doit être effectué par des adultes.
RISQUE D'ASPHYXIE - Ce produit contient de petites pièces et de petites boules. Ne convient pas aux enfants de moins de 3 ans.

PARTS IDENTIFIER

IDENTIFICADOR DE PIEZAS

IDENTIFICATEUR DE PIÈCES

PART NUMBER
NÚMERO DE PIEZA
NUMÉRO D'ARTICLE

PART
PIEZA
PIÈCE

PART NAME

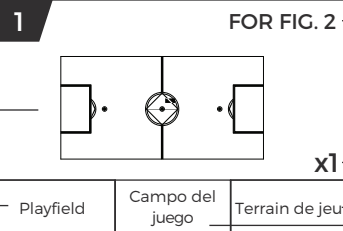
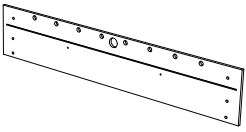
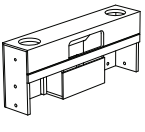
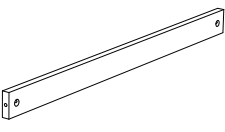
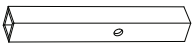
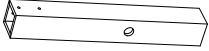



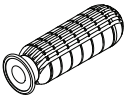


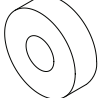


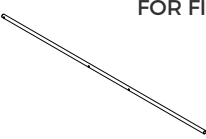
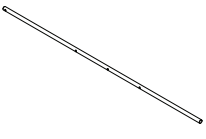
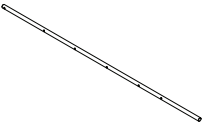








FIG NUMBER
NÚMERO DE FIG
NUMÉRO FIG

QUANTITY
CANTIDAD
QUANTITÉ

NOM DE LA PIÈCE
NOMBRE DE PIEZA

<p>2 FOR FIG. 1</p>  <p>x2</p>			<p>3 FOR FIG. 1, 4</p>  <p>x2</p>			<p>4 FOR FIG. 3</p>  <p>x2</p>			<p>5 FOR FIG. 6</p>  <p>x2</p>		
Side Apron	Delantal lateral	Tablier latéral	End Apron	Delantal final	Tablier final	Support Brace	Abrazadera de soporte	Barre de support	Left Leg	Pata izda	Pied gauche
<p>6 FOR FIG. 5</p>  <p>x2</p>			<p>7 FOR FIG. 7</p>  <p>x4</p>			<p>8 FOR FIG. 10</p>  <p>x2</p>			<p>9 FOR FIG. 6</p>  <p>x2</p>		
Right Leg	Pata dcha	Pied droit	Leg Leveler	Nivelador de pata	Niveleur de pied	Slide Scorer	Marcador deslizador	Marqueur à main	Cross Bar	Barra transversal	Barre transversale
<p>10 FOR FIG. 10</p>  <p>x8</p>			<p>11 FOR FIG. 8</p>  <p>x13</p>			<p>12 FOR FIG. 8</p>  <p>x13</p>			<p>13 FOR FIG. 8, 9</p>  <p>x16</p>		
Handle	Manija	Poignée	Player - Blue	Jugador - azul	Joueur - bleu	Player - Black	Jugador - negro	Joueur - noir	Rod Bumper	Amortiguador de barra	Tampon de tige
<p>14 FOR FIG. 8, 9</p>  <p>x16</p>			<p>15 FOR FIG. 10</p>  <p>x8</p>			<p>16 FOR FIG. 8, 9</p>  <p>x2</p>			<p>17 FOR FIG. 8, 9</p>  <p>x4</p>		
Rod Washer	Arandela de barra	Rondelle de tige	Rod End Cap	Gorra de barra final	Capuchon de bout de tige	2-Hole Rod	Barra de 2 agujeros	Tige à 2 trous	3-Hole Rod	Barra de 3 agujeros	Tige à 3 trous
<p>18 FOR FIG. 8, 9</p>  <p>x2</p>			<p>19 FOR FIG. 9</p>  <p>x13</p>			<p>20 FOR FIG. 9</p>  <p>x13</p>			<p>21 FOR FIG. 9</p>  <p>x13</p>		
5-Hole Rod	Barra de 5 agujeros	Tige à 5 trous	Player Head -Gray	Cabeza de jugador-gris	Tête lecteur-gris	Player Front-Gray	Jugador delantero-gris	Lecteur avant-gris	Player Back-Gray	Jugador trasero-gris	Lecteur arrière-gris
<p>22 FOR FIG. 9</p>  <p>x13</p>			<p>23 FOR FIG. 9</p>  <p>x13</p>			<p>24 FOR FIG. 9</p>  <p>x13</p>					
Player Head -Blue	Cabeza de jugador-azul	Tête lecteur-bleu	Player Front-Blue	Jugador delantero-azul	Lecteur avant-bleu	Player Back-Blue	Jugador trasero-azul	Lecteur arrière-bleu			

⚠ WARNING

One more for #19, #20, #21, #22, #23 and #24 is attached respectively, please keep them properly!

⚠ ADVERTENCIA

Uno más del #19, #20, #21, #22, #23 y #24 adjuntados respectivamente, por favor, manténgalos correctamente.


⚠ ATTENTION

Un de plus pour #19, #20, #21, #22, #23 et #24 est respectivement joint, veuillez les conserver correctement!

ACCESSORIES

ACCESORIOS

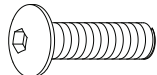
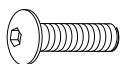
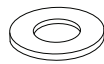
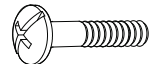

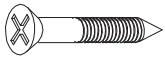


ACCESSOIRES

25		
		
x2		
Soccer Ball	Bola de fútbol	Ballon de foot

HARDWARE

HARDWARE





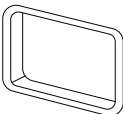

MÉTAUX

A1 FOR FIG. 5, 7  x8			A2 FOR FIG. 1, 4, 5, 7  x12			A3 FOR FIG. 1, 4, 5, 7  x20			A4 FOR FIG. 8  x26		
1/4\" data-bbox="78 344 138 364">Bolt	Perno 1/4\" data-bbox="148 344 208 364">x45mm	Boulon 1/4\" data-bbox="218 344 278 364">x45mm	1/4\" data-bbox="288 344 348 364">Bolt	Perno 1/4\" data-bbox="358 344 418 364">x28mm	Boulon 1/4\" data-bbox="428 344 488 364">x28mm	1/4\" data-bbox="498 344 558 364">Washer	Arandela 1/4\" data-bbox="568 344 628 364">	Rondelle 1/4\" data-bbox="638 344 698 364">	2.8x18.5 mm Bolt	Perno 2.8x18.5mm	Boulon 2.8x18.5mm
A5 FOR FIG. 8  x26			A6 FOR FIG. 10  x4			A7 FOR FIG. 3  x4			A8  x1		
Nut	Tuerca	Écrou	F3.5x45mm Screw	Tornillo F3.5x45mm	Vis F3.5x45mm	T4x38mm Screw	Tornillo T4x38mm	Vis T4x38mm	Allen Key	Llave allen	Clé hexagonale

PRE-INSTALLED PARTS

PIEZAS PREINSTALADAS

PIÈCES PRÉINSTALLÉES

P1 FOR FIG. 5, 6  x4			P2 FOR FIG. 1, 4, 5, 6  x20			P3 FOR FIG. 1  x2			P4 FOR FIG. 1  x16		
5/16\" data-bbox="78 614 138 634">T - Nut	Tuerca - T 5/16\" data-bbox="148 614 208 634">	Écrou en T 5/16\" data-bbox="218 614 278 634">	1/4\" data-bbox="288 614 348 634">T - Nut	Tuerca - T 1/4\" data-bbox="358 614 418 634">	Écrou en T 1/4\" data-bbox="428 614 488 634">	Ball Entry Rim	Aro de entrada para pelota	Ouverture d'entrée du ballon	Rod Bushing	Cojinete de para barra	Douille de la tige
P5 FOR FIG. 1, 4  x2			P6 FOR FIG. 1, 4  x2								
Ball Return Cover	Cubierta de retorno de bola	Cache retour de balle	Goal Cover	Cubierta de gol	Couverture de but						

BEFORE ASSEMBLY

ANTES DE MONTAR

AVANT L'ASSEMBLAGE

1. Find a clean, level place to begin the assembly of your product.
2. Verify that you have all listed parts as shown on the part list pages. If any parts are missing, call our customer service.

1. Encuentre un lugar limpio y nivelado para comenzar el ensamblaje del producto.
2. Compruebe que tenga todas las piezas que se muestran en la lista de piezas. Si falta alguna pieza, llame a nuestro servicio al cliente.

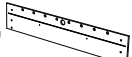






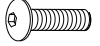


1. Trouvez un endroit propre et plat pour commencer à assembler votre produit.
2. Vérifiez que vous avez toutes les pièces énumérées comme indiqué sur les pages de liste des pièces. S'il y a des pièces qui manquent, appelez notre service clientèle.

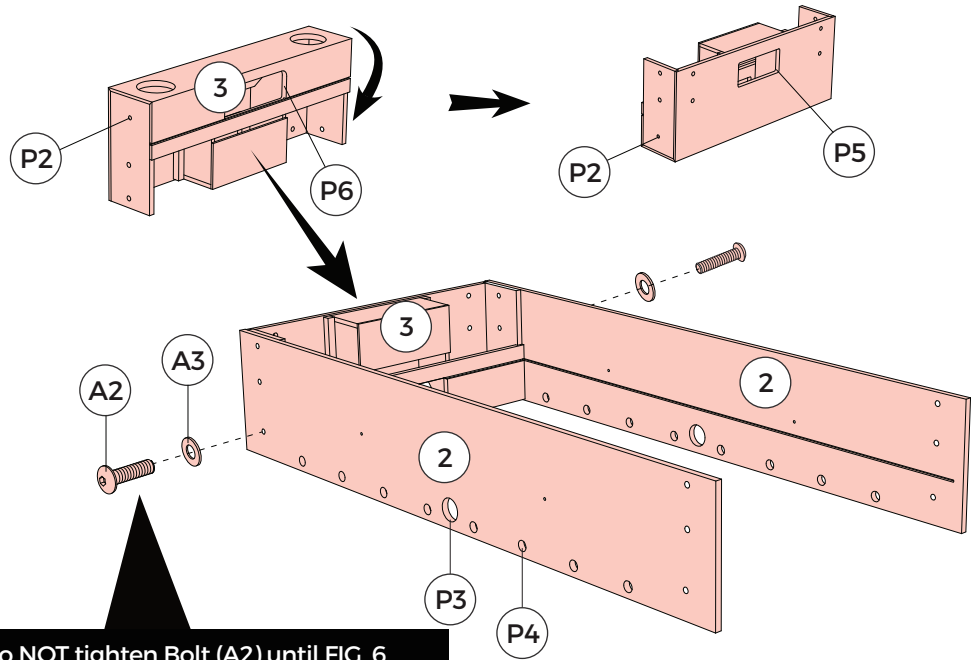
ASSEMBLY

MONTAJE

ASSEMBLAGE

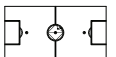
FIG. 1

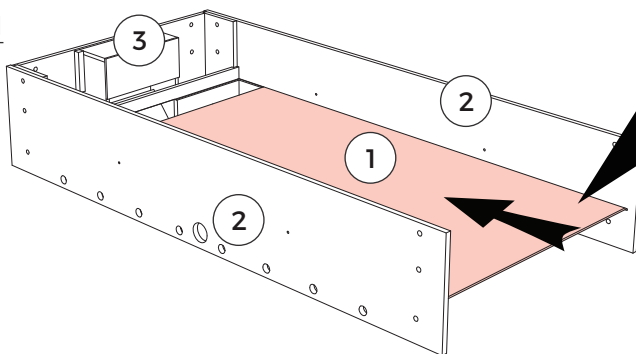
- 2**  x2
- P3**  x2
Pre-installed
- P4**  x16
Pre-installed
- 3**  x1
Pre-installed
- P2**  x2
Pre-installed
- P5**  x1
Pre-installed
- P6**  x1
- A2**  x2
- A3**  x2
- A8**  x1



Note: Do NOT tighten Bolt (A2) until FIG. 6.
Nota: NO el pestillo perno (A2) hasta FIG. 6.
Note: NE PAS serrer le boulon (A2) avant FIG. 6.



FIG. 2

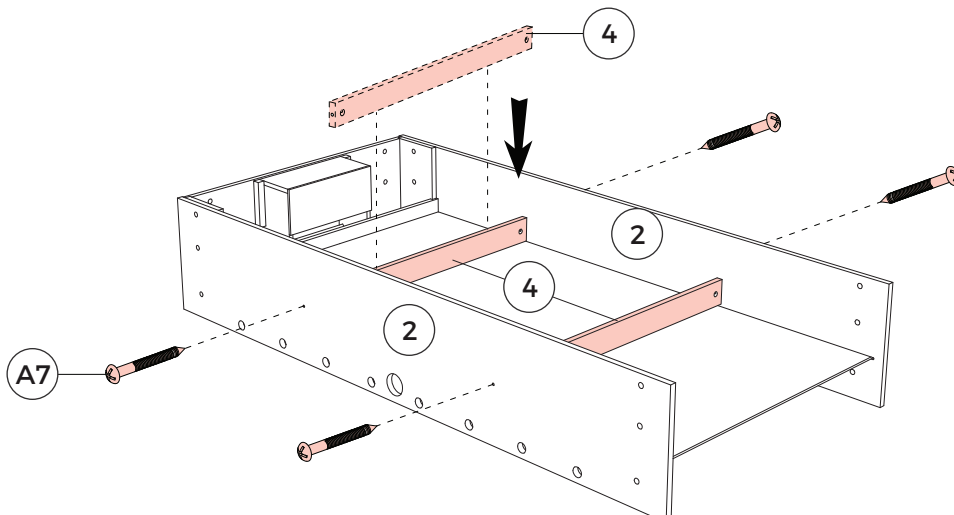
- 1**  x1



Note: Playfield graphic should face down when assembling.
Nota: El gráfico del campo de juego debe estar cara hacia abajo cuando está ensamblando.
Note: Le schéma du terrain de jeu doit être face vers le bas pendant l'assemblage.

FIG. 3

- 4**  x2
- A7**  x4

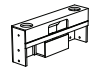



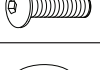




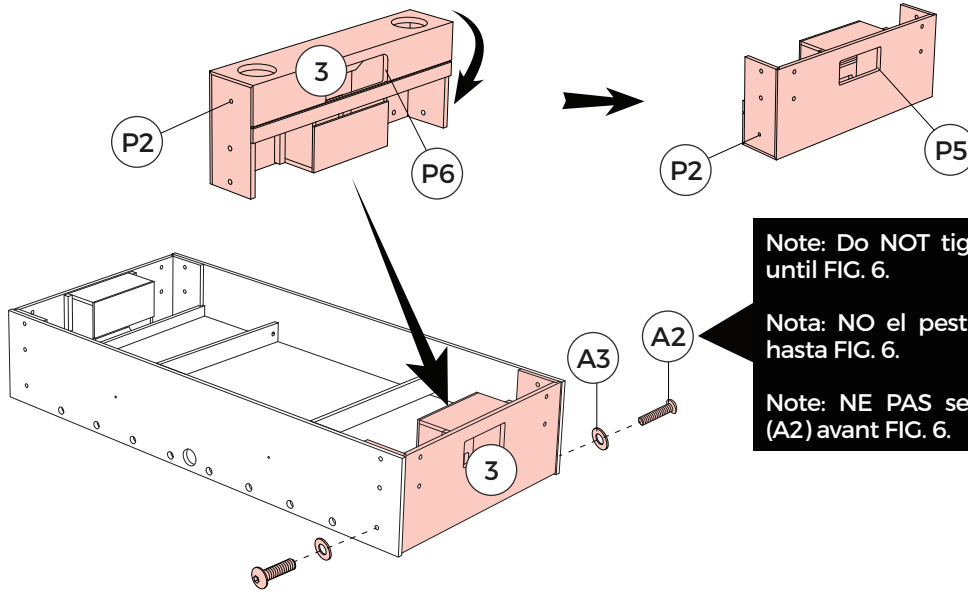
ASSEMBLY

MONTAJE

ASSEMBLAGE

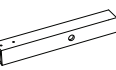


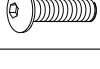



FIG. 4

- 3**  x1
Pre-installed
- P2**  x2
Pre-installed
- P5**  x1
Pre-installed
- P6**  x1
Pre-installed
- A2**  x2
- A3**  x2
- A8**  x1



Note: Do NOT tighten Bolt (A2) until FIG. 6.
Nota: NO el pestillo perno (A2) hasta FIG. 6.
Note: NE PAS serrer le boulon (A2) avant FIG. 6.

FIG. 5

- 6**  x2
Pre-installed
- P1**  x2
Pre-installed
- P2**  x8
- A1**  x4
- A2**  x4
- A3**  x8
- A8**  x1

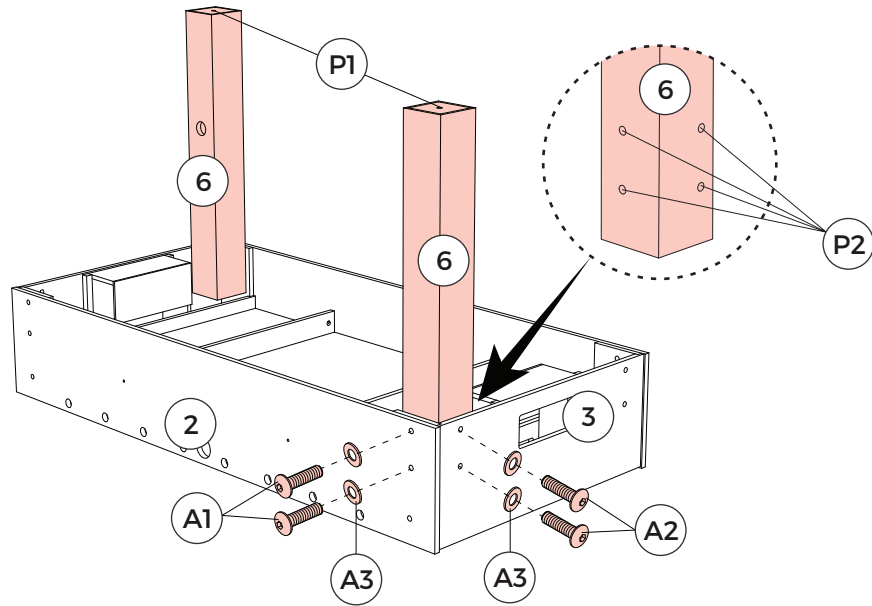
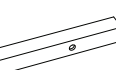



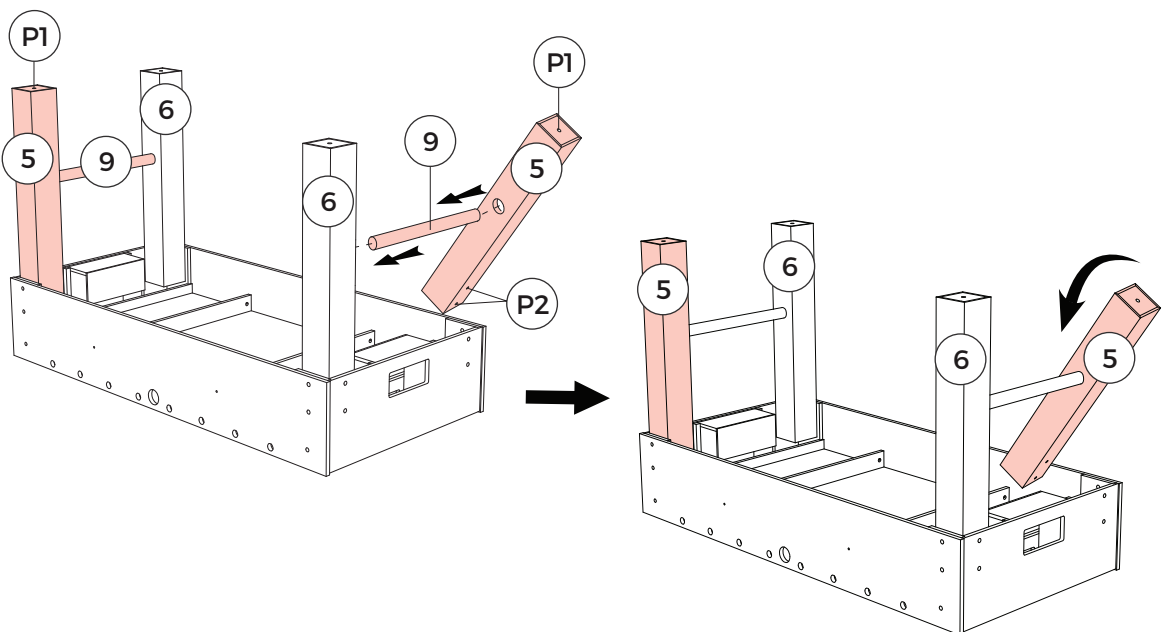


FIG. 6

- 5**  x2
Pre-installed
- P1**  x2
Pre-installed
- P2**  x8
- 9**  x2

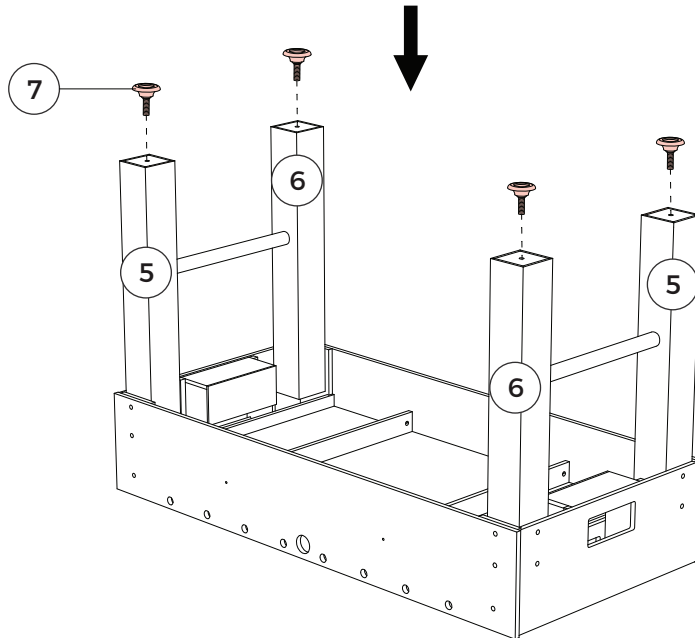
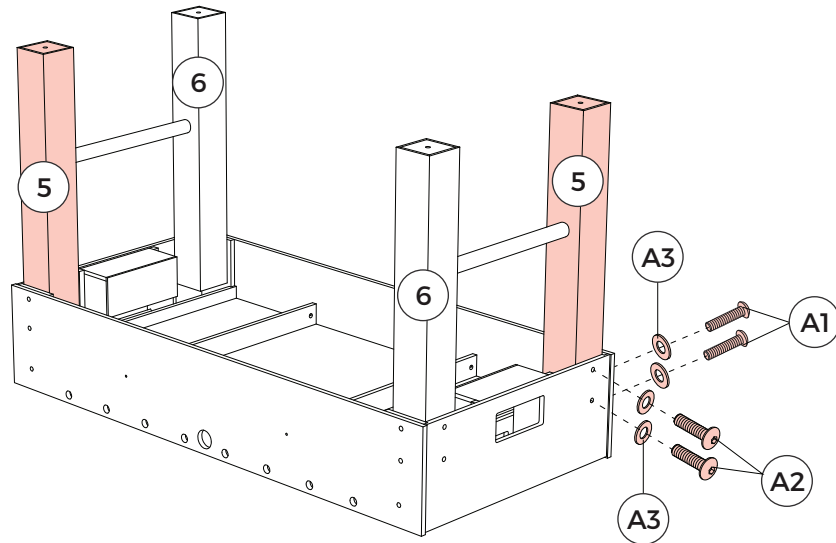
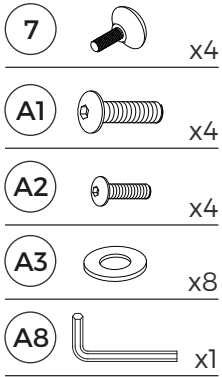


ASSEMBLY

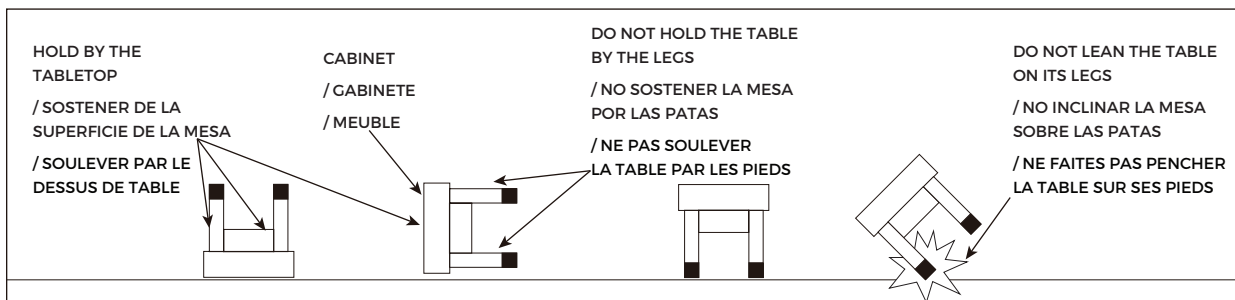
MONTAJE

ASSEMBLAGE

FIG. 7



Note: Go back and make sure that all connections are tight.
 Nota: Vuelva y asegúrese que todas las conexiones están apretadas.
 Note: Revérifiez que toutes les connexions sont bien serrées.

**⚠ CAUTION**

Two strong adults are recommended to turn over the table as shown.

1. Lift the table off the ground.
2. Turn the table over.
3. Place it on all feet at the same time on the ground.

⚠ PRECAUCIÓN

Se recomienda la participación de dos adultos para invertir la mesa como se muestra.

1. Levantar la mesa del suelo.
2. Voltee la mesa.
3. Coloque las patas de la mesa sobre el piso al mismo tiempo.

⚠ ATTENTION

La présence de Deux adultes robustes est recommandée pour tourner la table comme sur Fig.

1. Soulevez la table du sol.
2. Retournez-la.
3. Placez ses pieds sur le sol simultanément.








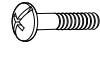

ASSEMBLY

MONTAJE

ASSEMBLAGE

FIG. 8

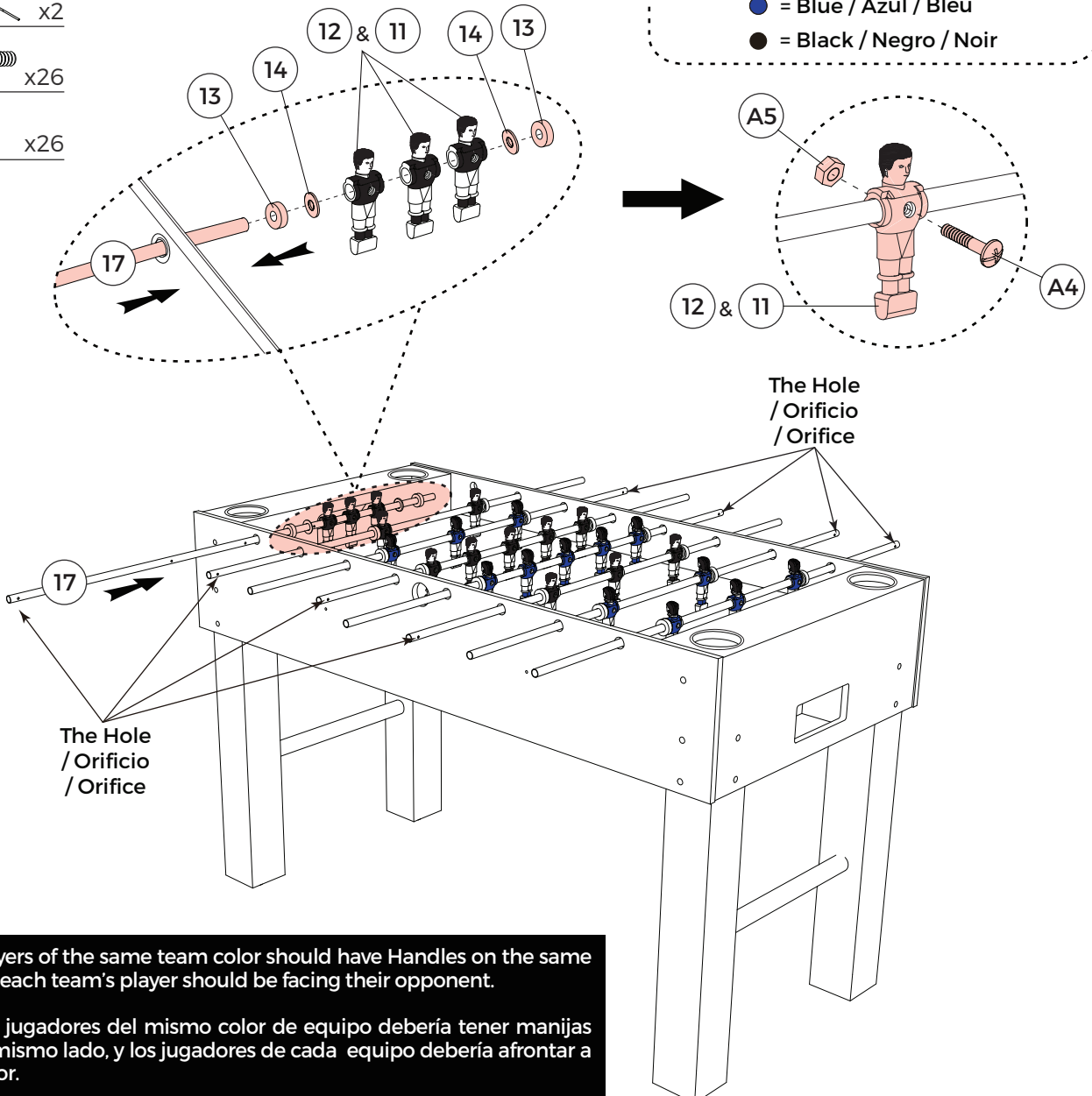
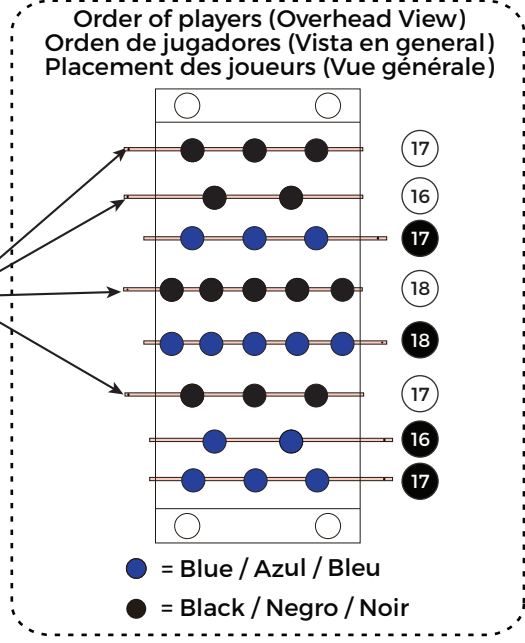
Player - Blue & Player - Black
Jugador - azul & Jugador - negro
Joueur - bleu & Joueur - noir

- 11  x13
- 12  x13
- 13  x16
- 14  x16
- 16  x2
- 17  x4
- 18  x2
- A4  x26
- A5  x26

Note: The Rods have a hole at the end where their Handles will go.

Nota: Las barras de jugador hay un agujero en su parte final donde coloque las manijas.

Note: Les tiges joueur ont un orifice à leur extrémité où placer les poignées.



Note: Players of the same team color should have Handles on the same side, and each team's player should be facing their opponent.

Nota: Los jugadores del mismo color de equipo debería tener manijas sobre el mismo lado, y los jugadores de cada equipo debería afrontar a su opositor.

Note: Les joueurs de la même couleur d'équipe doivent avoir leurs poignées du même côté et chaque équipe faire face à l'équipe opposée.












ASSEMBLY

MONTAJE

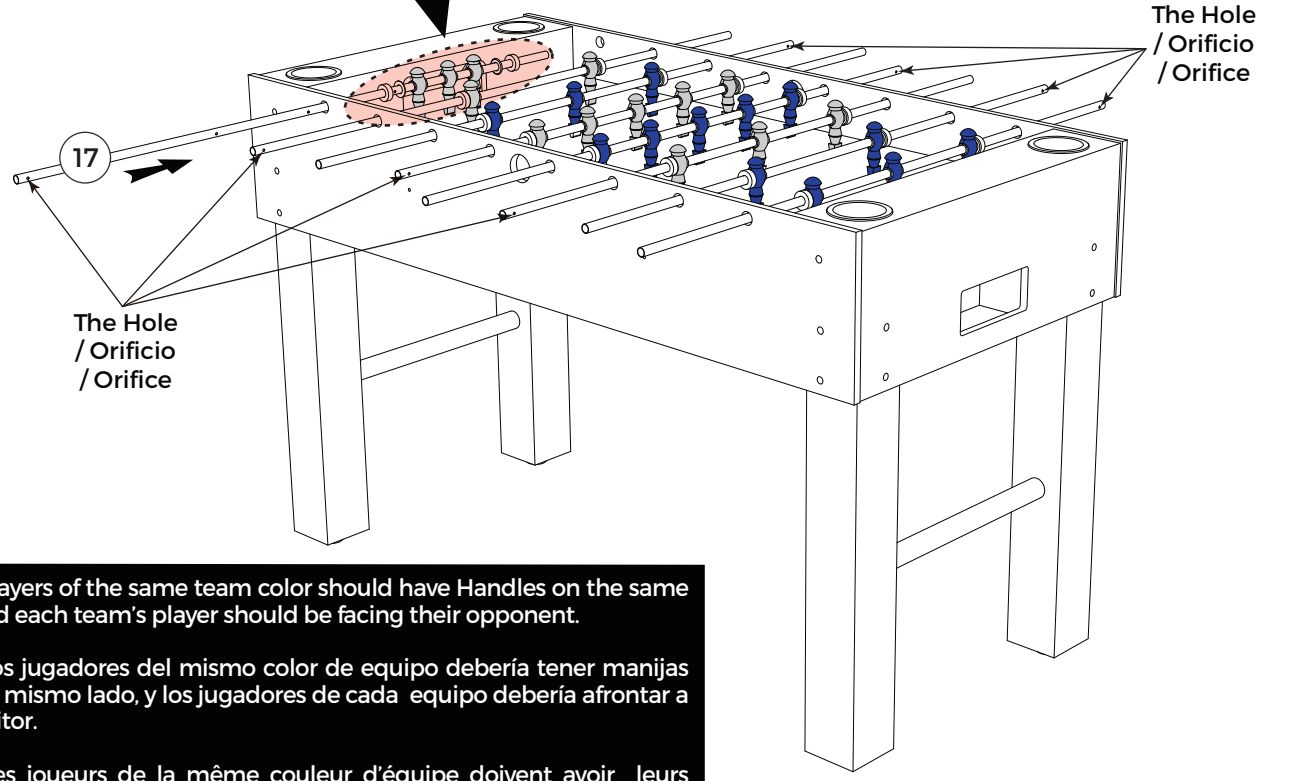
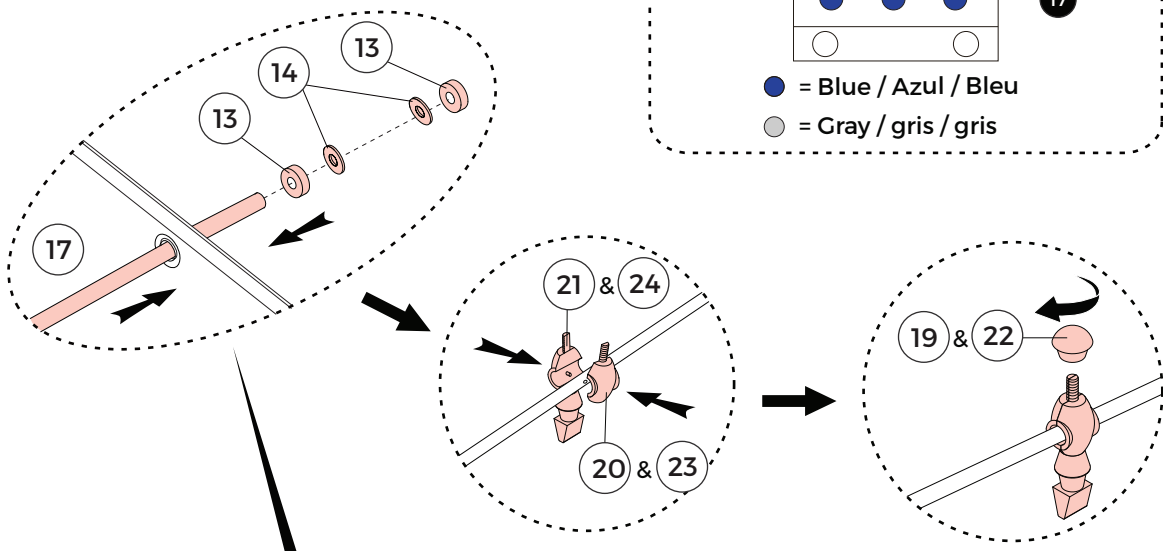
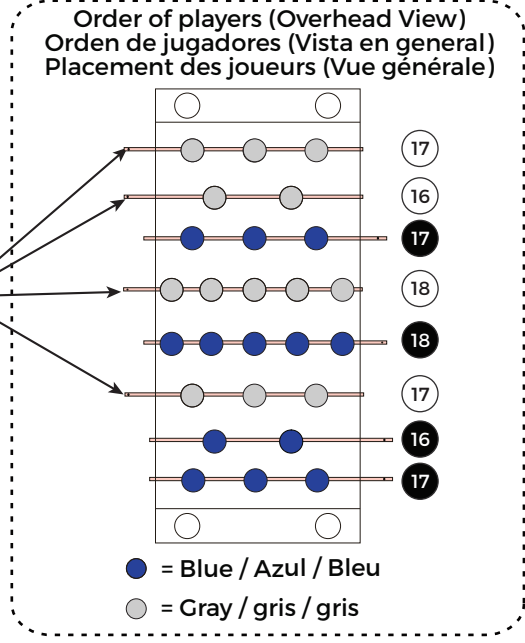
ASSEMBLAGE

FIG. 9

Player - Gray & Player - Blue
Jugador - gris & Jugador - azul
Joueur - gris & Joueur - bleu

- 13  x16
- 14  x16
- 16  x2
- 17  x4
- 18  x2
- 19  x13
- 20  x13
- 21  x13
- 22  x13
- 23  x13
- 24  x13

Note: The Rods have a hole at the end where their Handles will go.
Nota: Las barras de jugador hay un agujero en su parte final donde coloque las manijas.
Note: Les tiges joueur ont un orifice à leur extrémité où placer les poignées.



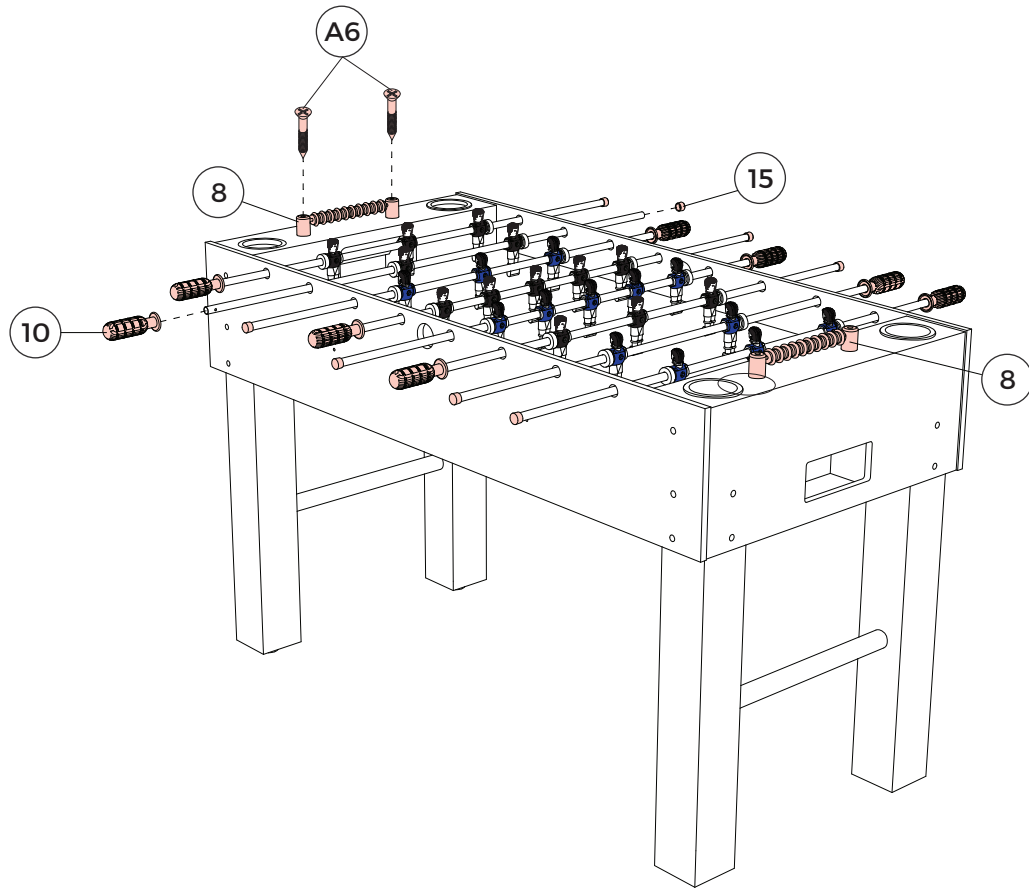
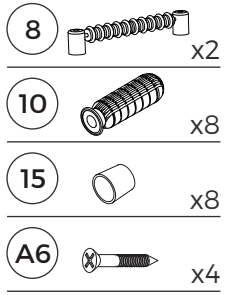
Note: Players of the same team color should have Handles on the same side, and each team's player should be facing their opponent.
Nota: Los jugadores del mismo color de equipo debería tener manijas sobre el mismo lado, y los jugadores de cada equipo debería afrontar a su opositor.
Note: Les joueurs de la même couleur d'équipe doivent avoir leurs poignées du même côté et chaque équipe faire face à l'équipe opposée.

ASSEMBLY

MONTAJE

ASSEMBLAGE

FIG. 10





www.medalsports.com