











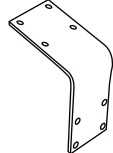

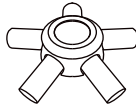
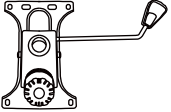
<p>A</p>  <p>x1</p>	<p>B</p>  <p>x1</p>	<p>C</p>  <p>x1</p>	<p>D</p>  <p>x5</p>	<p>E</p>  <p>x1</p>	<p>F</p>  <p>#17</p> <p>x1</p>	<p>G</p>  <p>#80 mm</p> <p>x1</p>
<p>H</p>  <p>x5</p>	<p>J</p>  <p>M6*12 mm</p> <p>x10</p>	<p>K</p>  <p>M6*20 mm</p> <p>x4</p>	<p>L</p>  <p>M6*20 mm</p> <p>x4</p>	<p>M</p>  <p>M6*30 mm</p> <p>x4</p>	<p>N</p>  <p>25*10*5 mm</p> <p>x2</p>	<p>O</p>  <p>x1</p>



Assembly Tips

- **STEP 1** - Remove the base cap before inserting the legs into the base connector (#E).
- **STEP 3** - Reattach the base cap to the base before inserting the gas lift.
- **STEP 3** - Hold the base firmly and push the casters in with strong pressure.
- **STEP 5** - Ensure the tilt function knob faces the front of the seat while attaching the base plate.
- **STEP 5** - Ensure to insert the washers (#N) first before attaching the connector plate (#C).
- **IMPORTANT** - DO NOT fully tighten the screws until all screws are properly placed into their holes.

NEXT PAGE: ASSEMBLY PROCESS

①

Screw Tightness: 50%

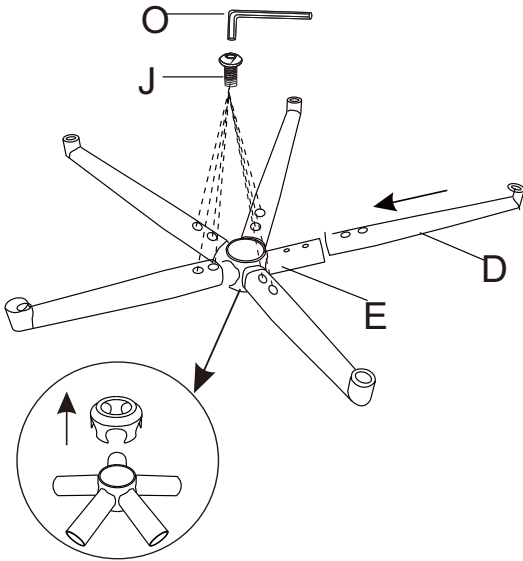

②

Screw Tightness: 100%

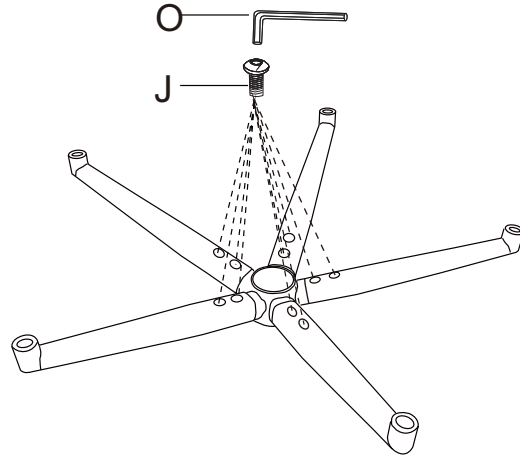

③

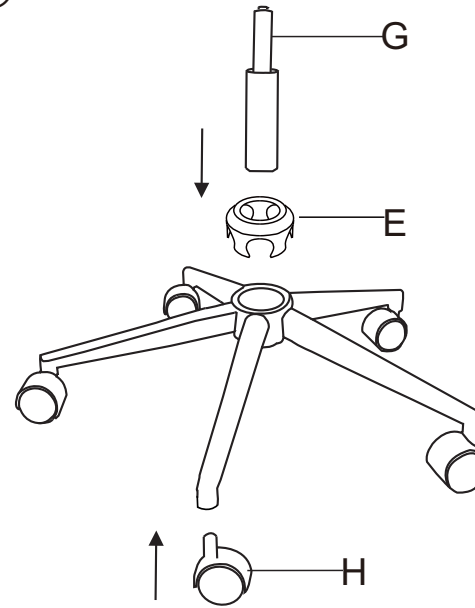

④

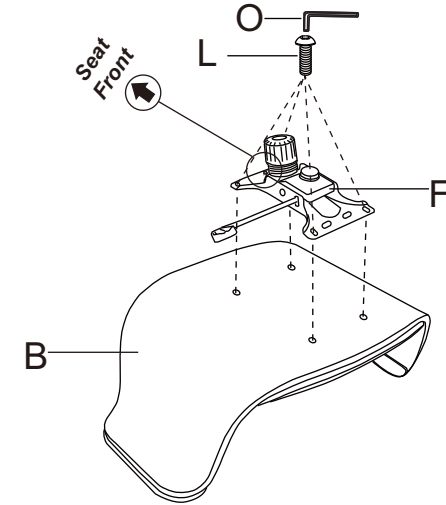

⑤

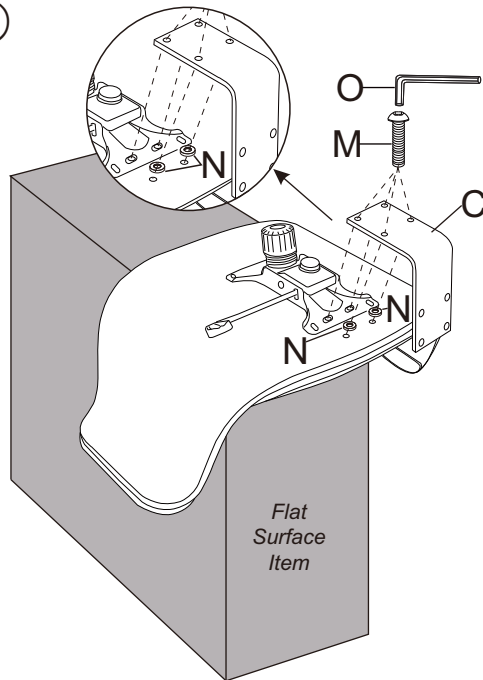

⑥

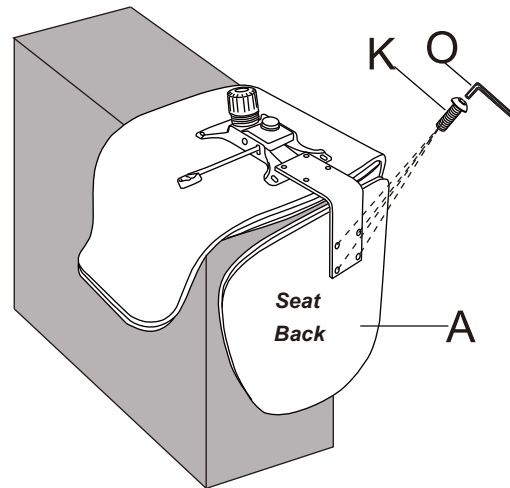

⑦

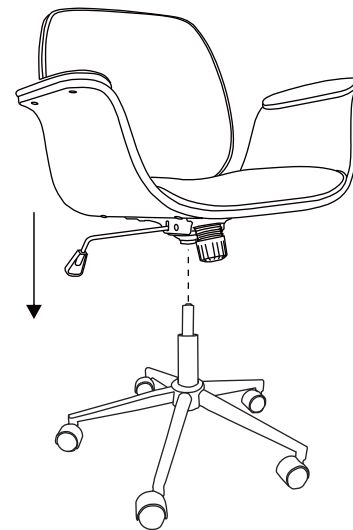

⑧

