

# ASSEMBLY INSTRUCTIONS

MODEL : TB8087

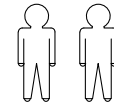

2 Persons Recommended

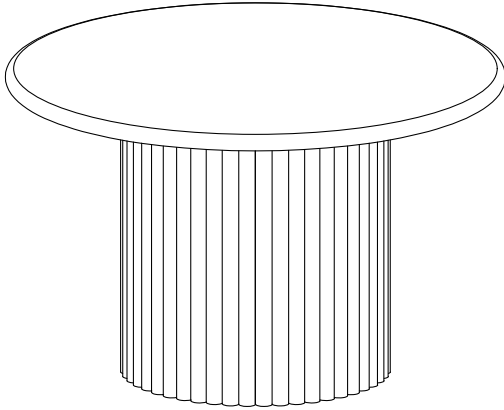

ITEM	HARDWARE LIST	DESCRIPTION	QTY
A	Wood Stand M8 x 65		4 PCS
B	JCBC Bolt M6 x 30		2 PCS
C	Spring Washer M8		4 PCS
D	Flat Washer M6 x 13		2 PCS
E	Wood Dowel M10 x 30		4 PCS
F	Allen Key M4 Long		1 PC
G	Adjuster 15mm		6 PCS
H	Hex Nut M8		4 PCS
I	Flat Washer M8		4 PCS
J	Spanner 13		1 PC

ITEM	PART NAME	QTY
1	Table Top	1 PC
2	Leg	2 PCS

## STEP 1

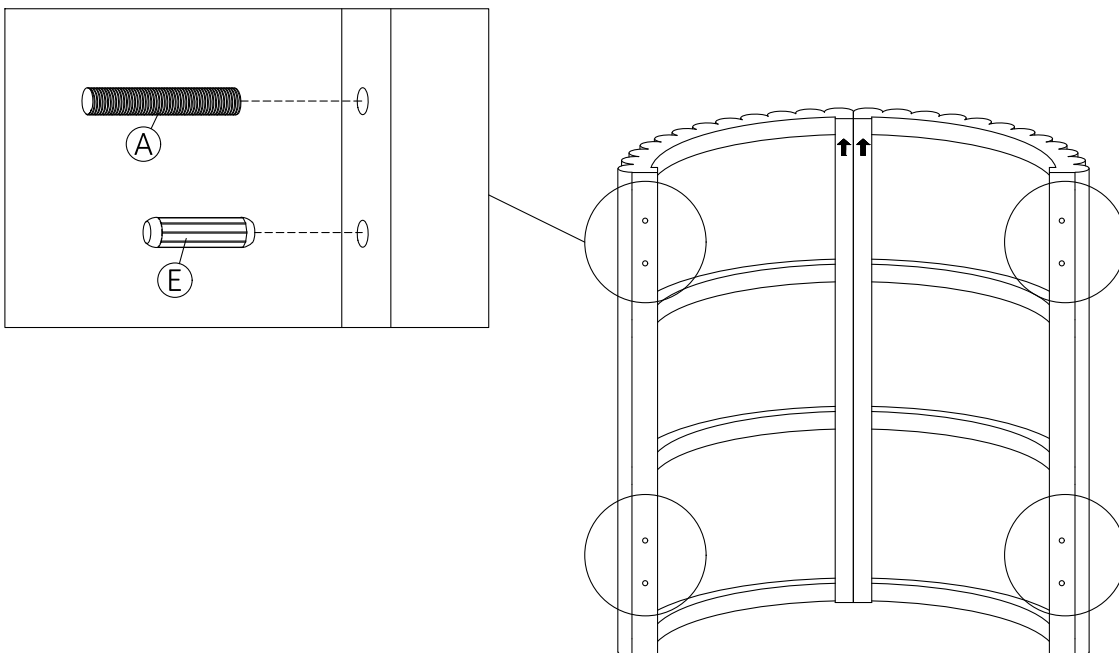

## STEP 2

Remark: Please make sure the **arrow** at the top.

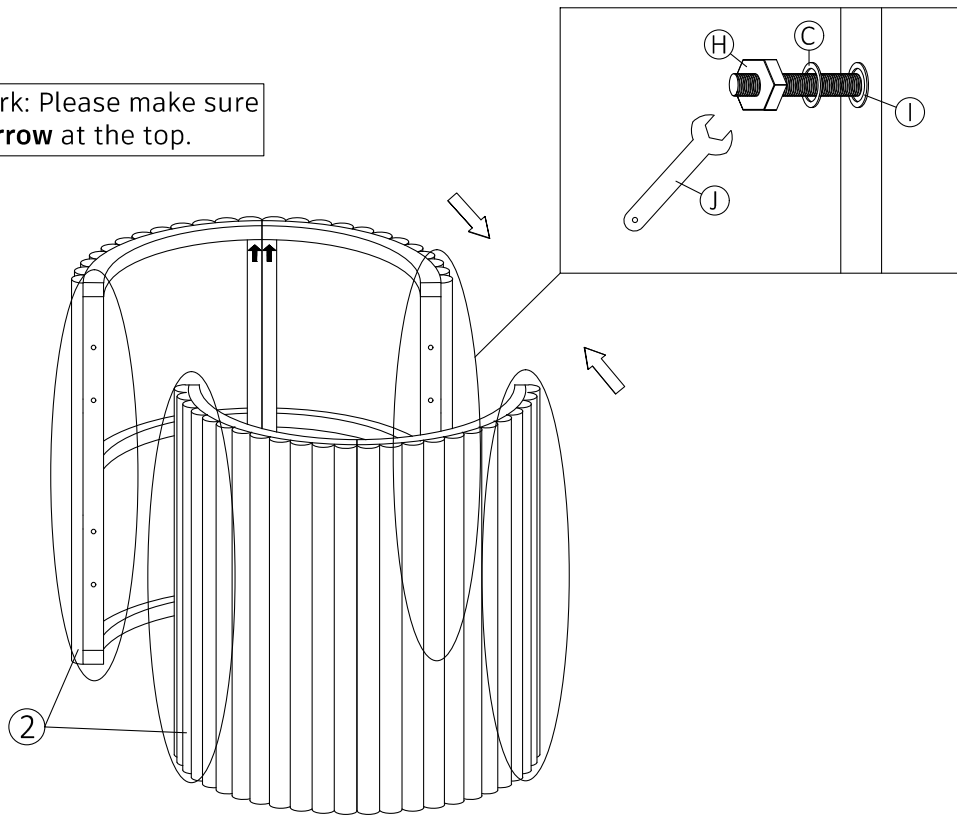

## STEP 3

