

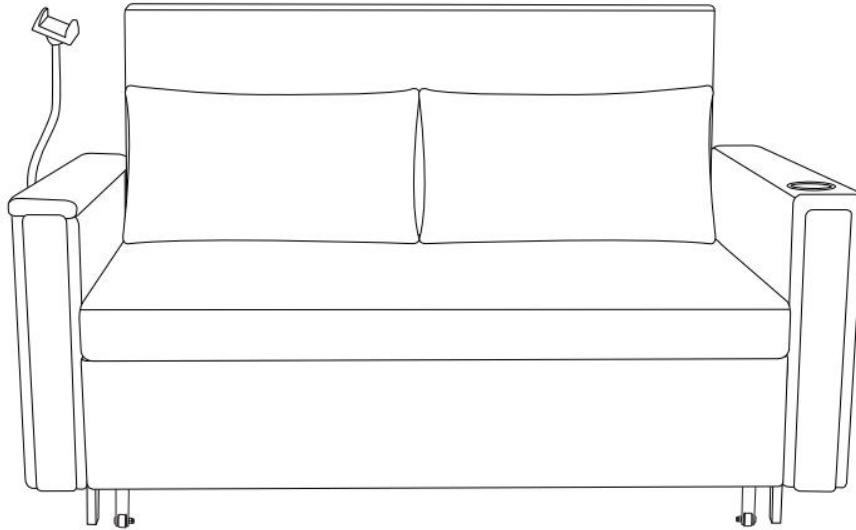





# Assembly Instructions



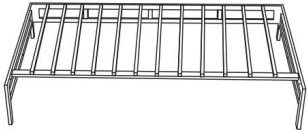

**Note: Please help to read my instruction before you ready to assemble.**

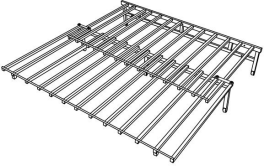
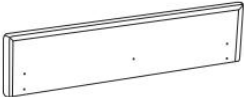
## LOVE SEAT

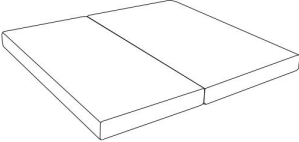













## **Part List**

Label	Picture	Description	QTY (PCS)
A		Iron Frame	1
B		Left Armrest (with cell phone holder)	1
C		Right Armrest (with cup holder)	1
D		Backrest	1
E		Iron Frame	1
F		Footrest	1
G		Folding Cushion Package	1
		Folding Cushion	1

H		Seat Cushion Package	1
		Seat Cushion	1
I		Waist Cushion	2
J		Middle Leg	1

## Hardware

①		Cell Phone Holder	1
②		Nut	1
③		Bolt(M8*40mm)	6
④		Bolt(M8*30mm)	5
⑤		Spring Washer (M8)	6
⑥		Flat Washer(M8)	11
⑦		Allen Wrench(S5)	1
⑧		Spanner	1
⑨		Bolt(M6*20mm)	2
⑩		Spring Washer (M6)	2
⑪		Flat Washer(M6)	2
⑫		Allen Wrench(S4)	1

## Assembly Preparation

All Including:

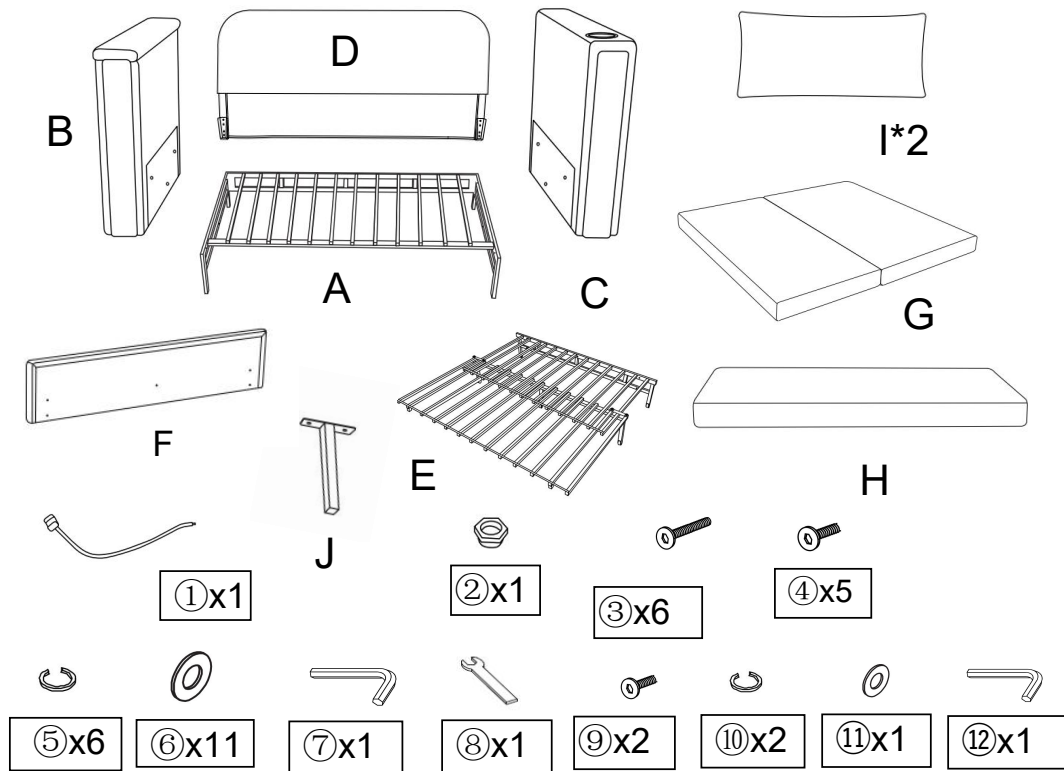

### NOTICE:

- Please read the instruction from cover to cover in detail.Thanks.
- Installed by at least two adults.
- To avoid damaging your furniture , Please don't assemble on flooring or carpet.
- Please assemble on a clean non-marring surface, example for packing foam.
- Saving all packaging until have finished.

## Assembly Steps

### Step 1

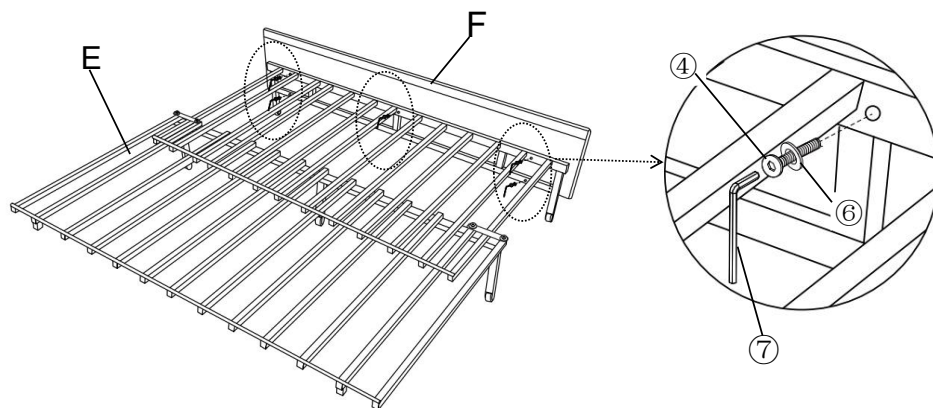

Install the Footrest (F) on the Iron Frame (E) by using Bolt (4)and Flat Washer(6) with Allen Wrench(7) turning clockwise until tight.

**Step 2**

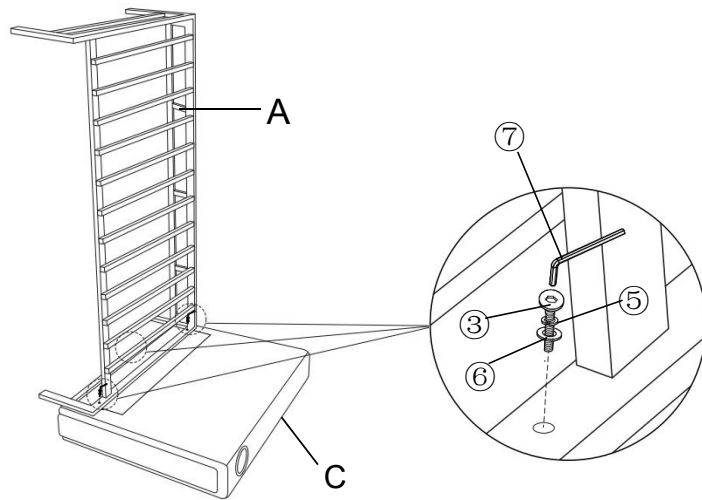

Install the Right Armrest(C) to the Iron Frame(A) by using Bolt(③), Spring Washer(⑤), Flat Washer(⑥), with Allen Wrench(⑦) turning clockwise until tight.

**Step 3**

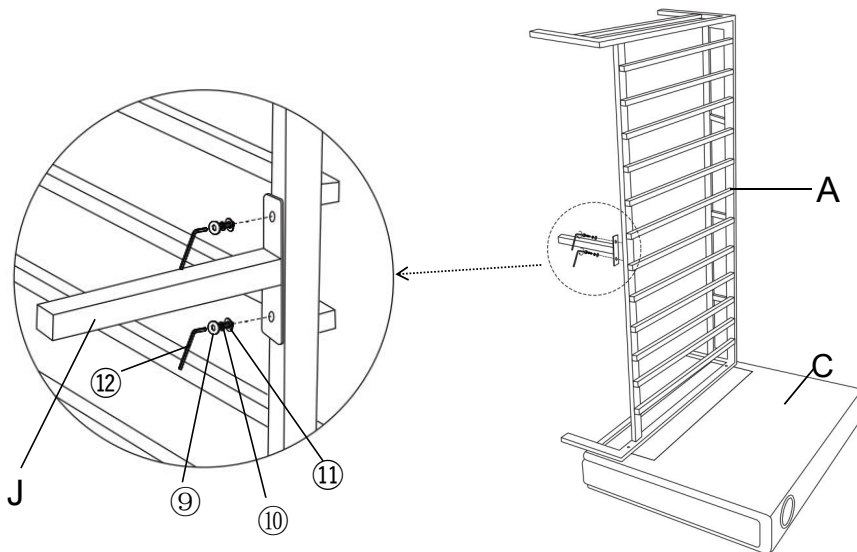

Install the Middle Leg (J) by using Bolt(⑨), Spring Washer(⑩), Flat Washer(⑪), with Allen Wrench(⑫) turning clockwise until tight.

**Step 4**

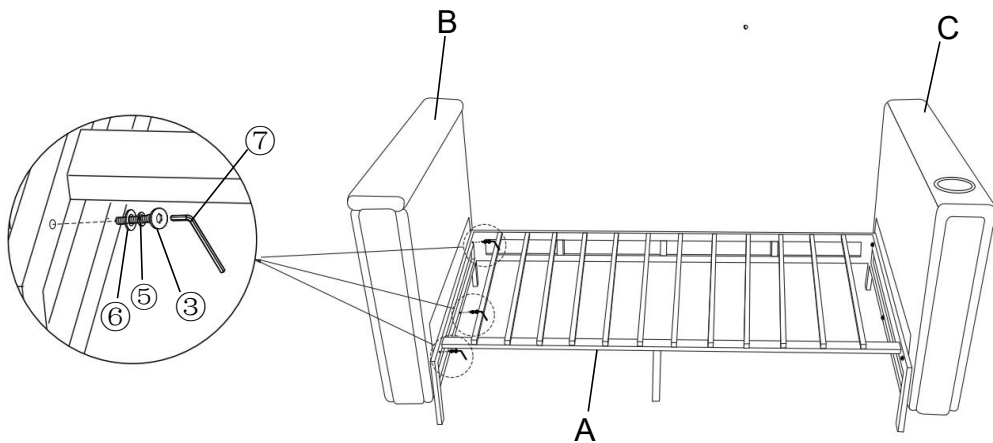

Position the other side up, install the Left Armrest(B) to the Iron Frame(A) by using Bolt(③) Spring Washer(⑤), Flat Washer(⑥), with Allen Wrench(⑦) turning clockwise until tight.

**Step 5**

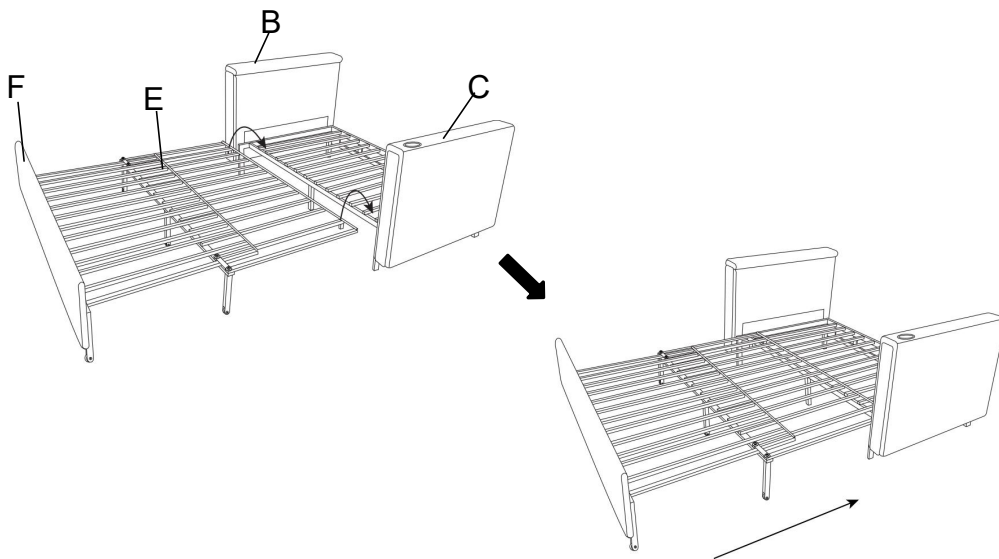

Put the Semi-assembly Part (Step 1) on Semi-assembly Part (Step 3), then push the Footrest (F) into love seat.

**Step 6**

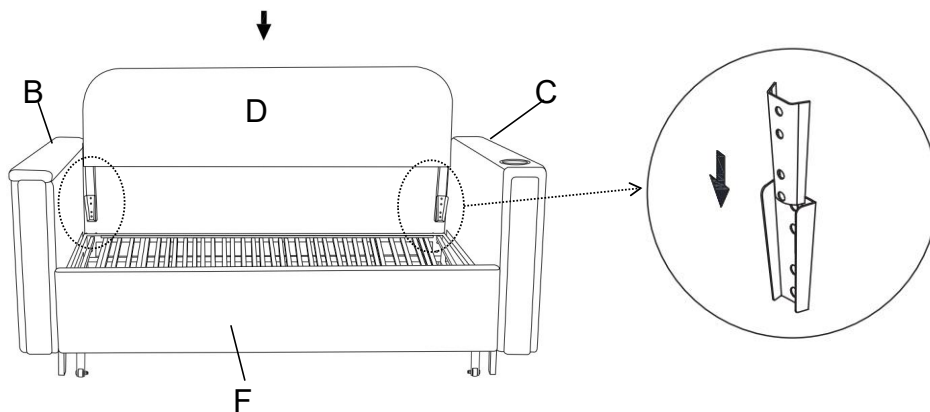

Slide the Tapered Connectors on the Backrest(D) into the Tapered Connectors on the Left Armrest(B) and Right Armrest(C) as shown in the picture.

**Step 7**

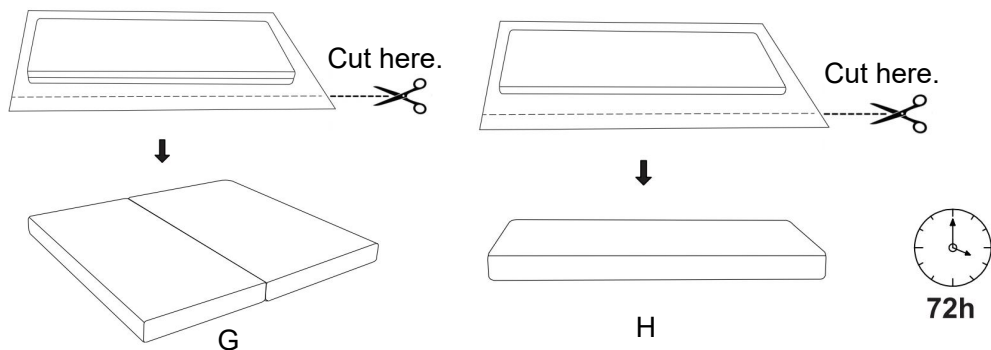

Cut the Folding Cushion Package (G) ,and Seat Cushion package(H) ,then take out cushions .Fully decompression may take up to 72 hours.

**Step 8**

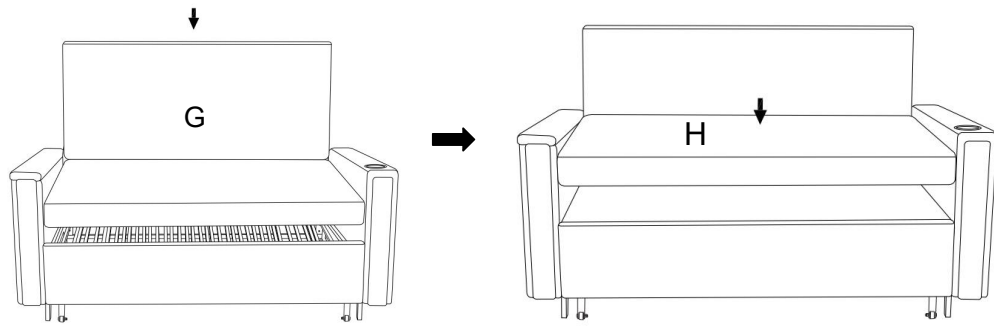

Respectively place the Folding Cushion(G) and Seat Cushion(H) on the love seat as picture shown.

**Step 9**

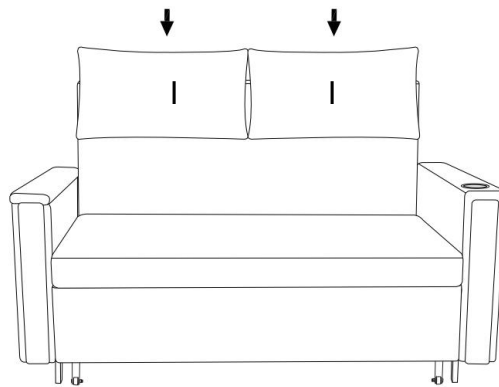

Place the two Waist Cushiones(I) on the love seat.

**Step 10**

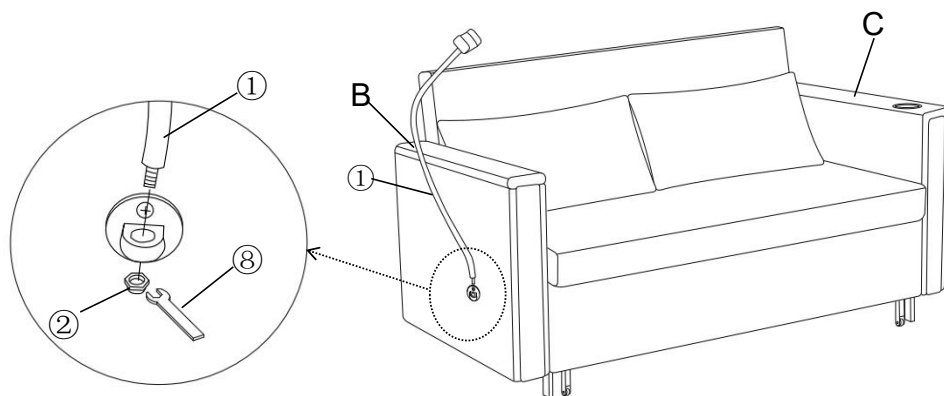

Position the love seat right side up,install the Cell Phone Holder(①) with Nut(②) and using Spanner(⑧) turning clockwise until tight. The love seat is ready for use.

## Step 11

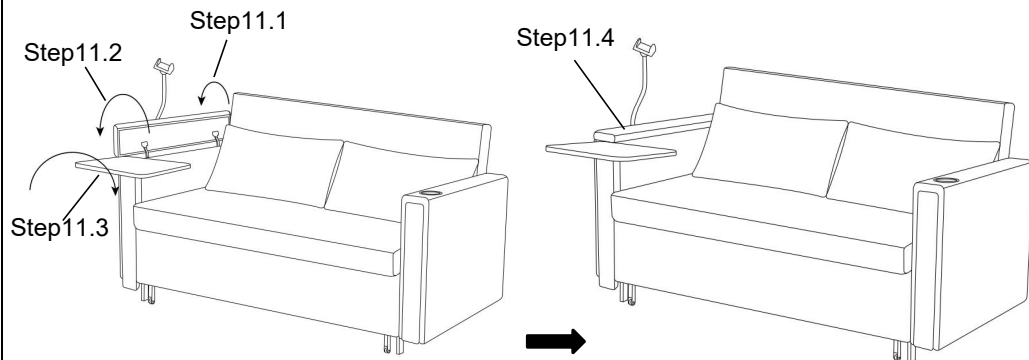

Take out the Removable table as the step below:

Step11.1: Open the lid on the Left Armrest(B) .

Step11.2: Slide down rope.

Step11.3: Take out the Removable table.

Step11.4: Close the lid on the Left Armrest(B) .

## Step 12

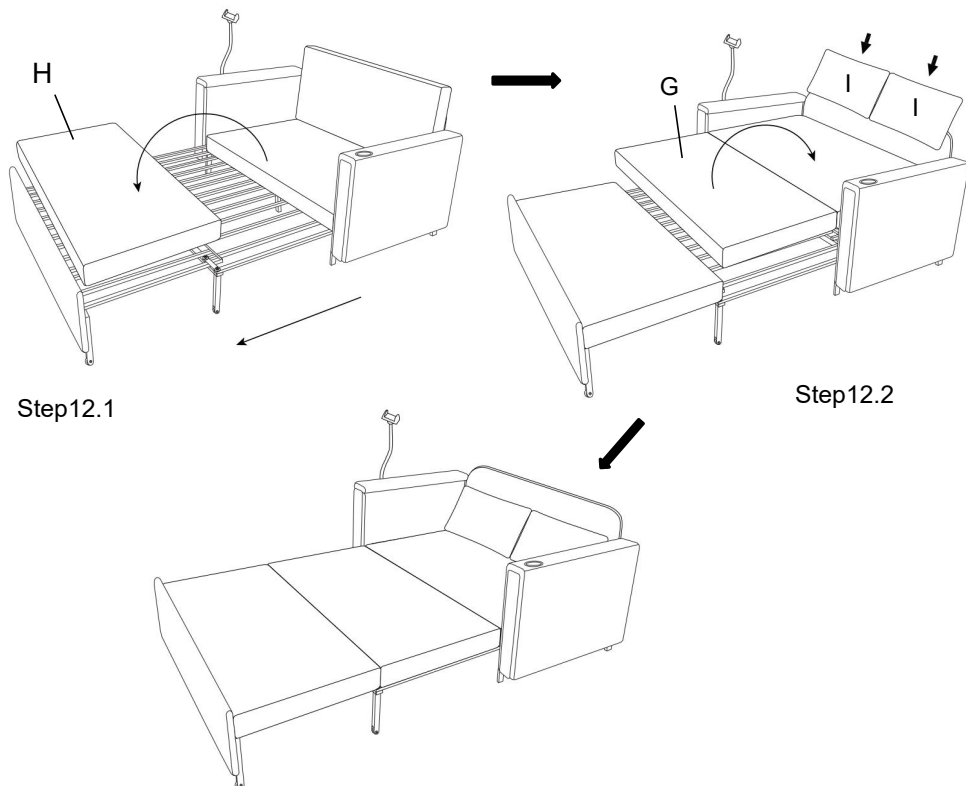

Step12.1: Pull out the Footrest(F) in a level line,then put the Seat Cushion(H) on iron frame.

Step12.2: Pull out and lie the Folding Cushion(G),then place the two Waist Cushiones(I) on the love seat.