

Assembly Instruction

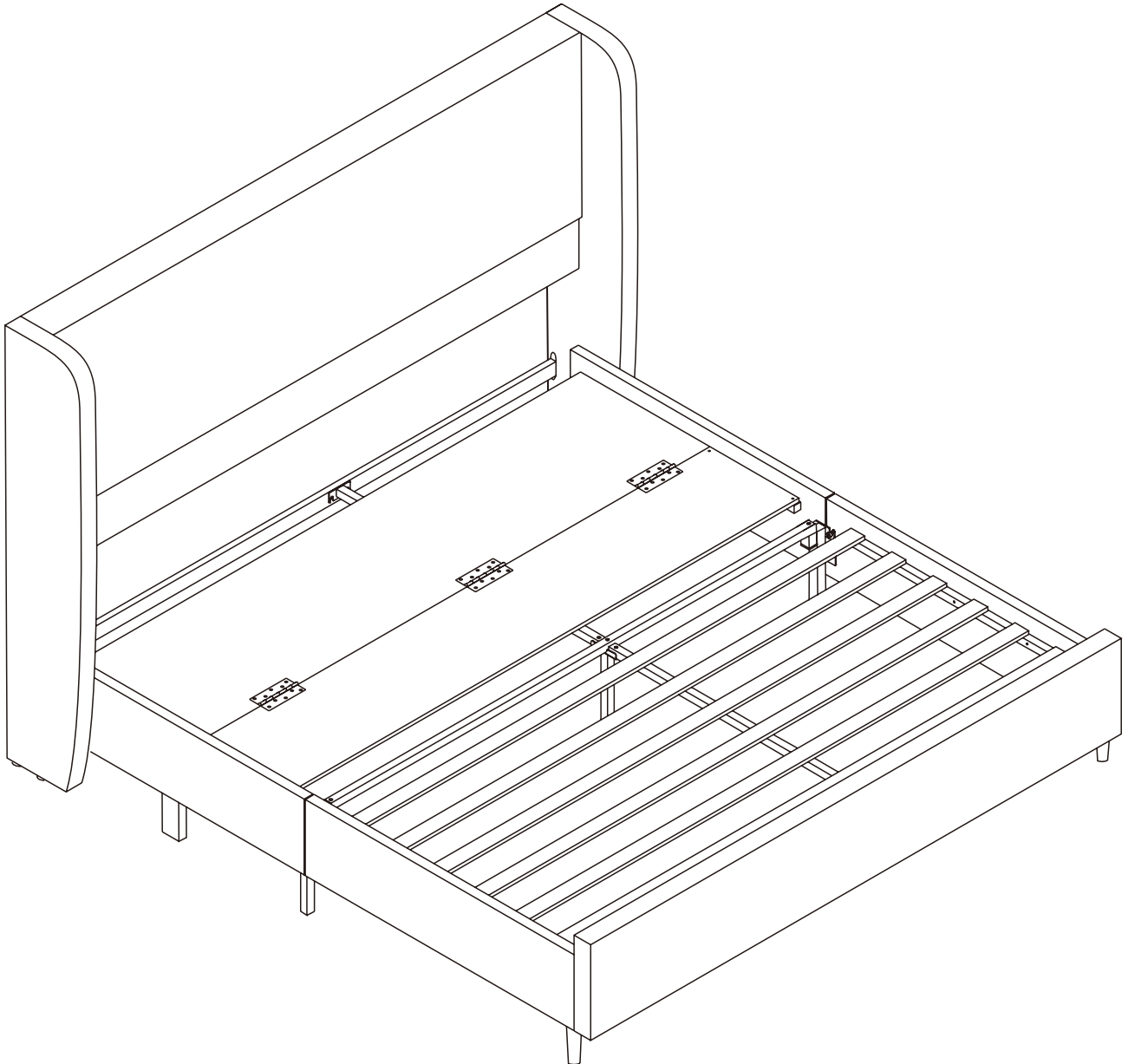

Please check that you have all the parts listed before you start assembling,if you do find that something is missing,do not continue assembly,please contact us immediately.

NOTE:Please do not completely tighten all the hardware until the entire assembly is complete!

! IMPORTANT

Please follow the instruction manuals and use a pad to protect the product during your assembly.

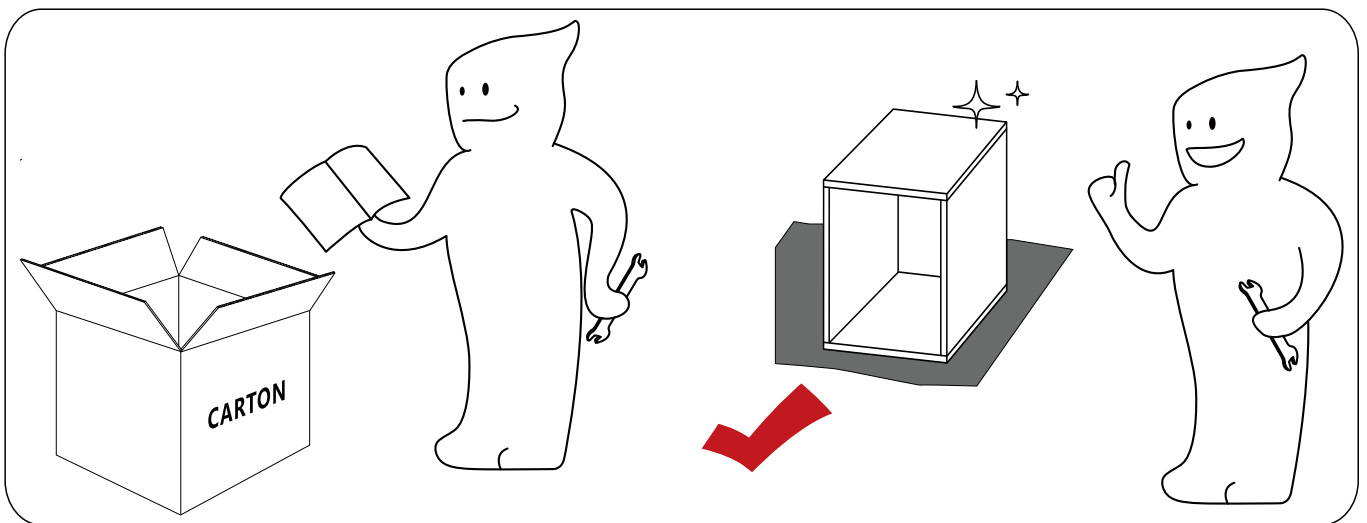
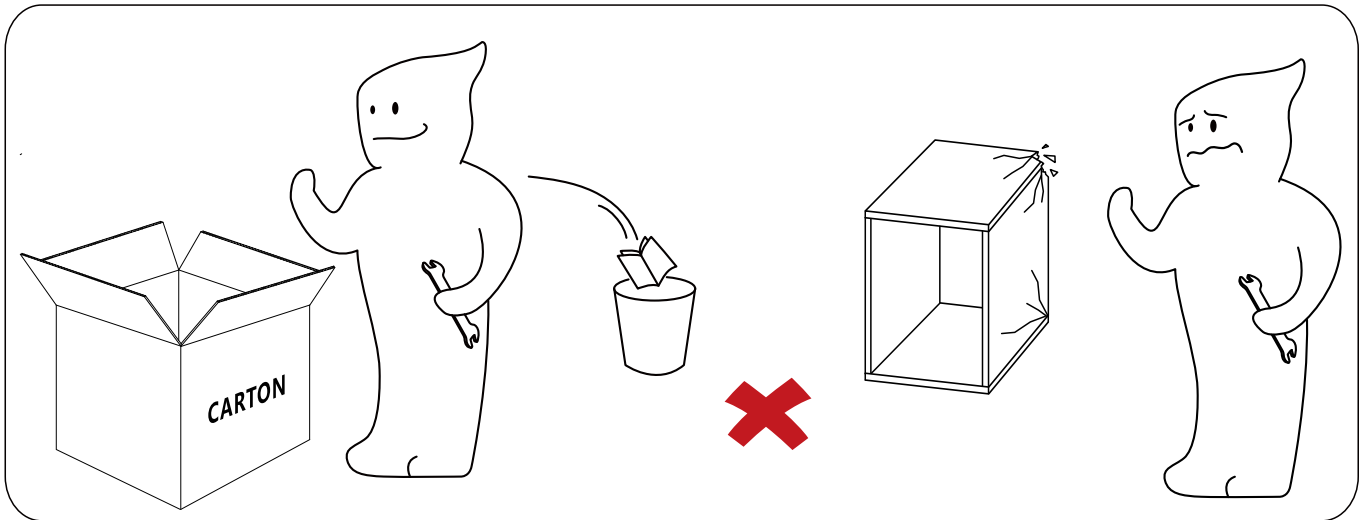

Note:

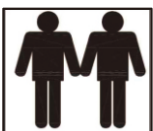

1. Should be assembled on flat ground to keep balance.
2. Before completing the installation, do not tighten the screws.

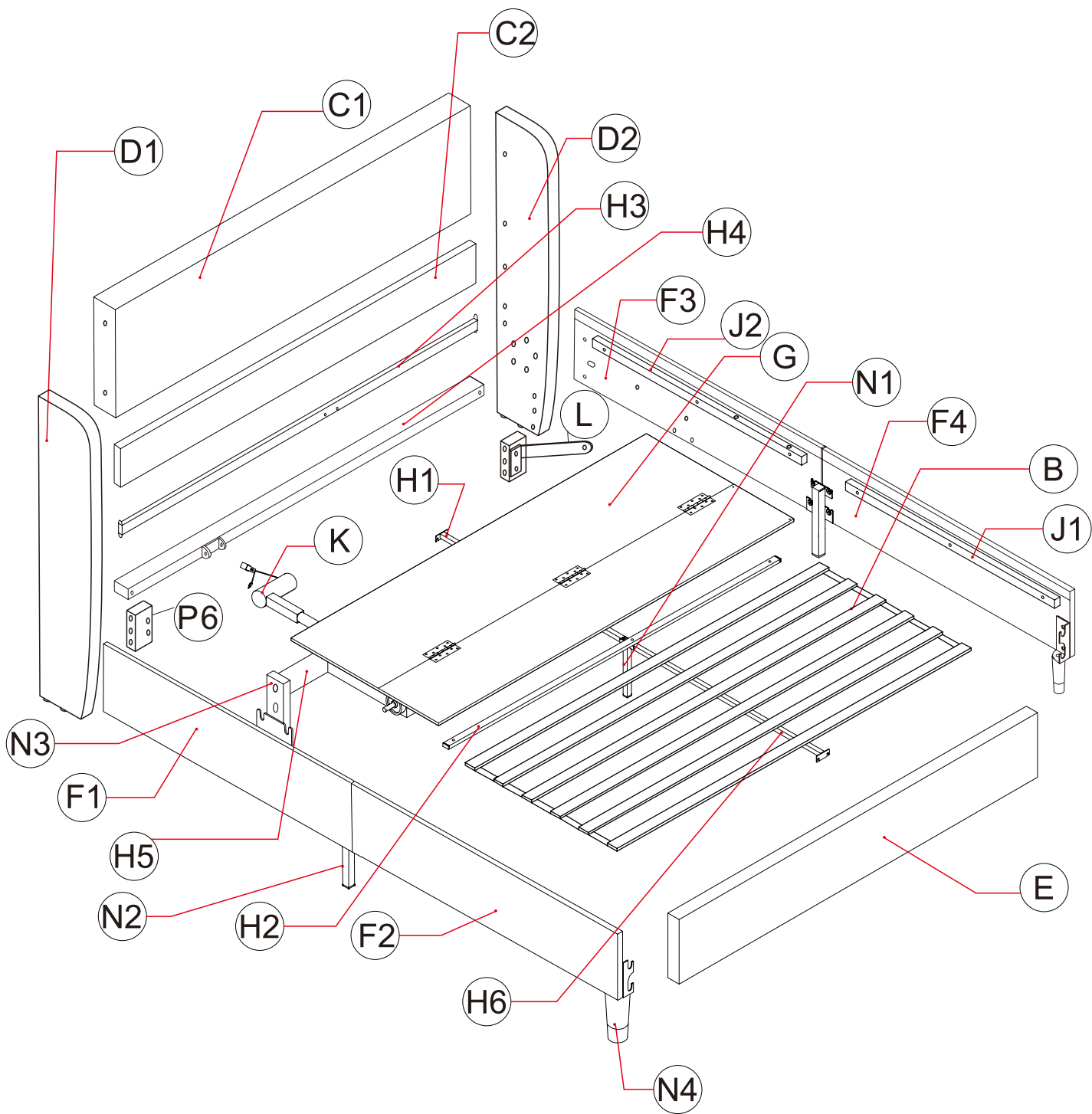

For easier and better assembly, **2** or more adults are required.

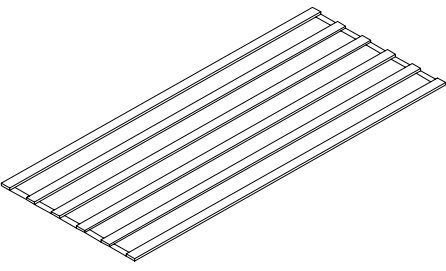
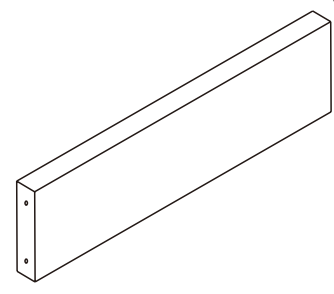
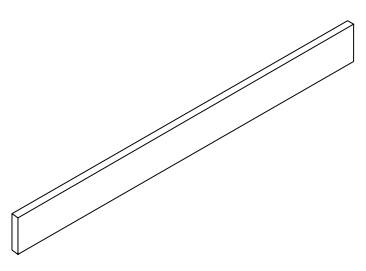
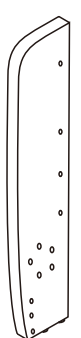

BED FRAME PARTS LIST

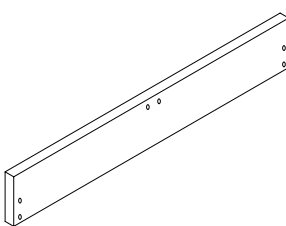
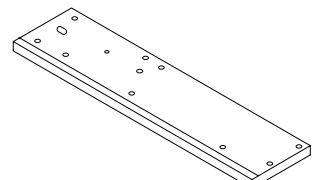
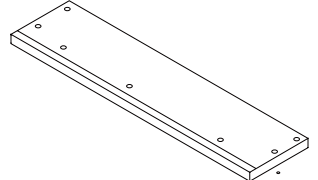
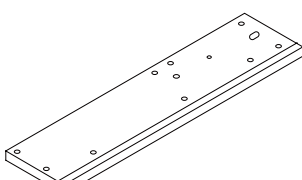
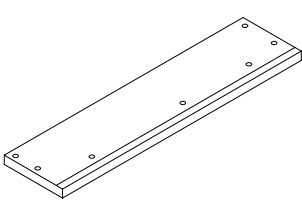
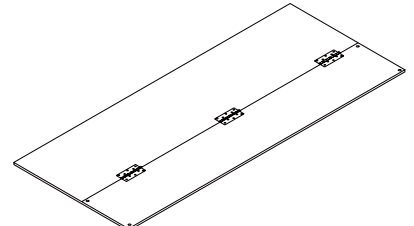
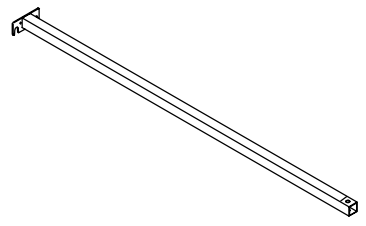
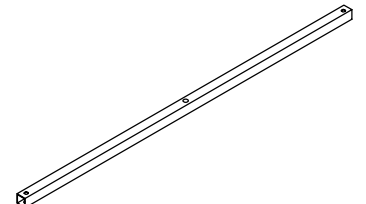
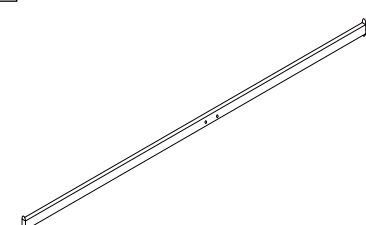
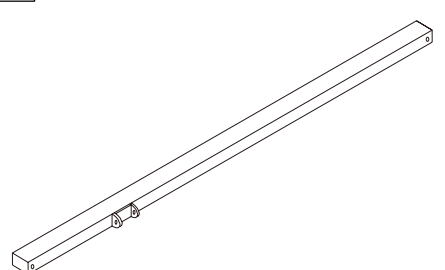
B  1PCS Slat	C1  1PC Top headboard	C2  1PC Top headboard
D1  1PC Left Leg	D2  1PC Right Leg	E  1PC Footboard
F1  1PC Side rail	F2  1PC Side rail	F3  1PC Side rail
F4  1PC Side rail	G  1PC Front support panel	H1  1PC Middle front support bar
H2  1PC Cross bar	H3  1PC Upper Headboard bar	H4  1PC Lower Headboard bar

BED FRAME PARTS LIST

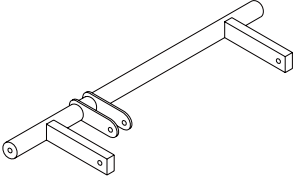
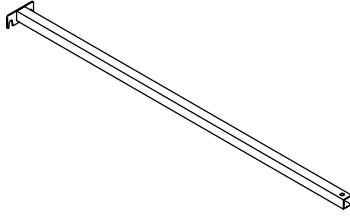
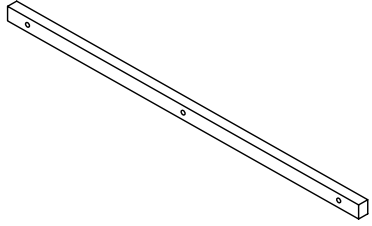
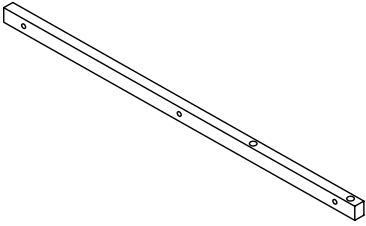
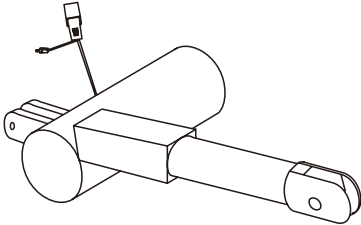
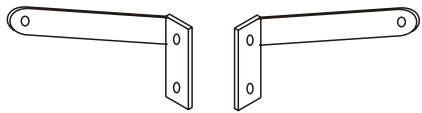
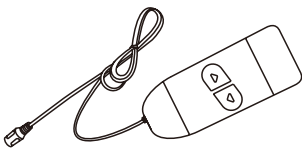
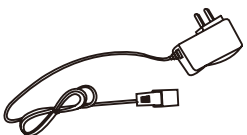
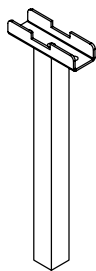
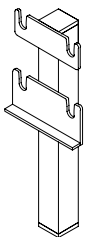
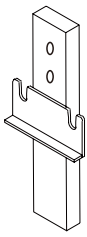
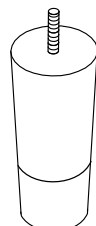
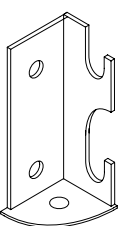
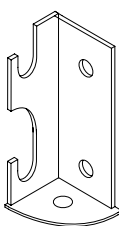
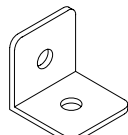
<p>H5 1PC</p>  <p style="text-align: center;">Drive rod</p>	<p>H6 1PC</p>  <p style="text-align: center;">Middle behind support bar</p>	<p>J1 2PCS</p>  <p style="text-align: center;">Side bar</p>
<p>J2 2PCS</p>  <p style="text-align: center;">Side bar</p>	<p>K 1PC</p>  <p style="text-align: center;">Gas-lifter</p>	<p>L 2PCS</p>  <p style="text-align: center;">Left Right</p>
<p>M1 1PC</p>  <p style="text-align: center;">Controllers</p>	<p>M2 1PC</p>  <p style="text-align: center;">Power cable</p>	<p>LN1 1PC</p>  <p style="text-align: center;">Middle support leg</p>
<p>N2 2PCS</p>  <p style="text-align: center;">Bed side support leg</p>	<p>SN3 2PCS</p>  <p style="text-align: center;">Bed side support leg</p>	<p>N4 2PCS</p>  <p style="text-align: center;">Foot</p>
<p>P1 1PC</p>  <p style="text-align: center;">Connector-P1</p>	<p>P2 1PC</p>  <p style="text-align: center;">Connector-P2</p>	<p>P3 5PCS</p>  <p style="text-align: center;">Connector-P3</p>

BED FRAME PARTS LIST

P4

1PC

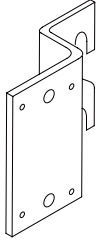

Connector-P4

P5

1PC

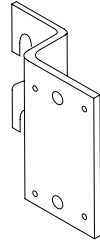

Connector-P5

P6

2PCS

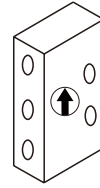



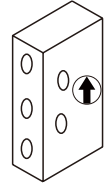



Left

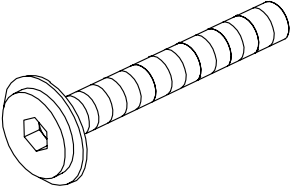
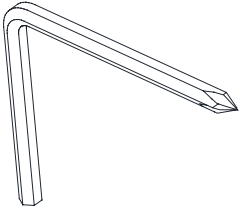

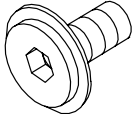
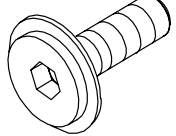
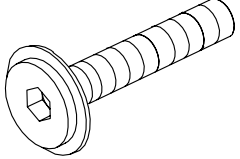
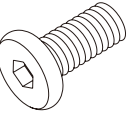
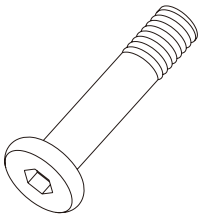
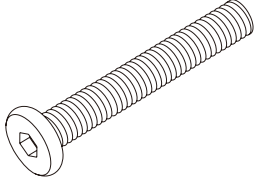
Right

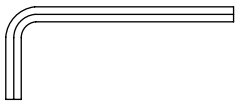
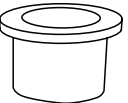
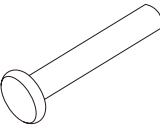
FITTING PART LIST

a	2PCS	b	6PCS	c	1PC	d	8PCS
							
		M8*65		M6		M4*45	
e	4PCS	f	40PCS	g	19PCS	h	12PCS
							
M8*40		M8*18		M8*35		M8*50	
i	4PCS	j	2PCS	k	2PCS	m	4PCS
							
M8*18		M10*37		M8*80			
n	1PC	o	8PCS	r	4PCS	s	4PCS
							
M8							
v	2PCS						
							

step1

f

M8*18

8PCS

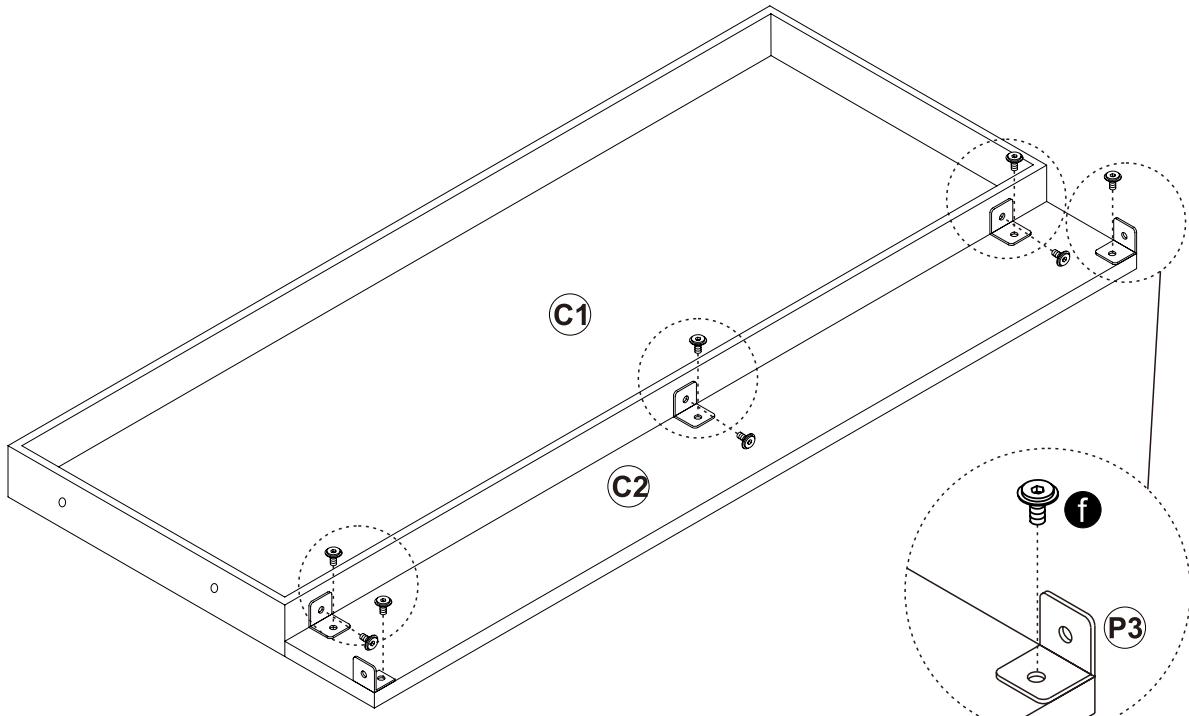

80% pre-screwed

step2

g

M8*35

4PCS

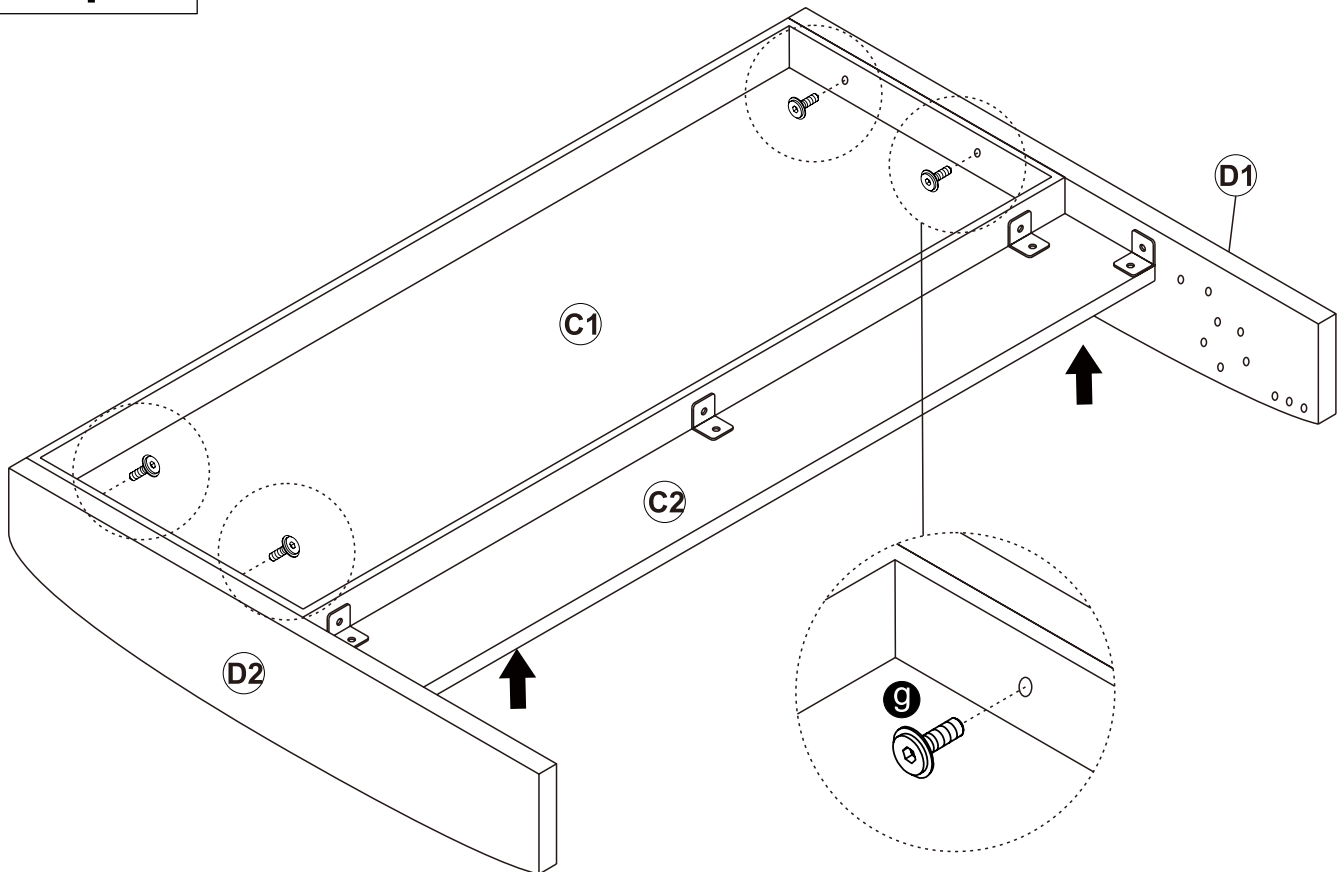

step3

f

M8*18

2PCS

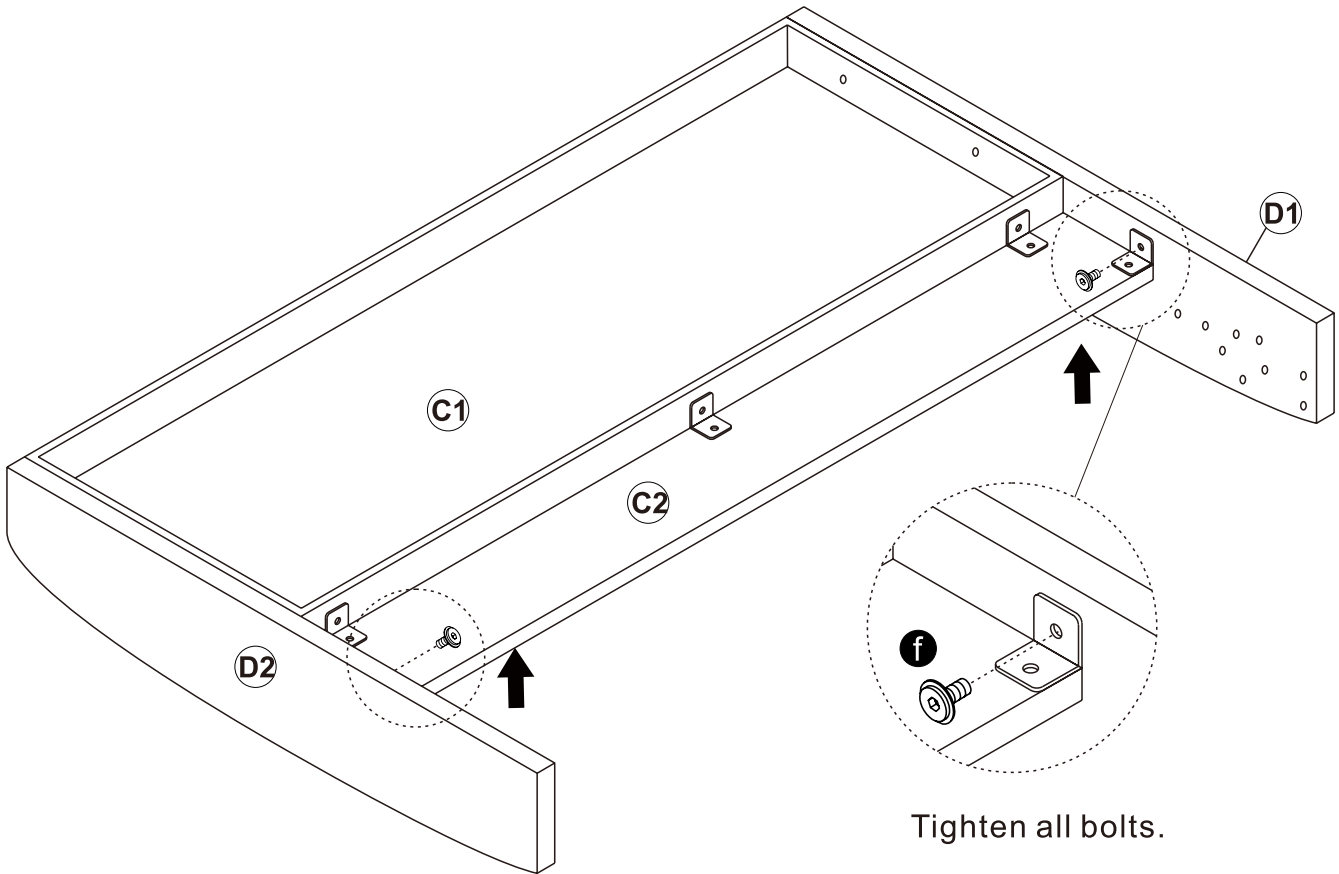

Tighten all bolts.

step4

i

M8*18

4PCS

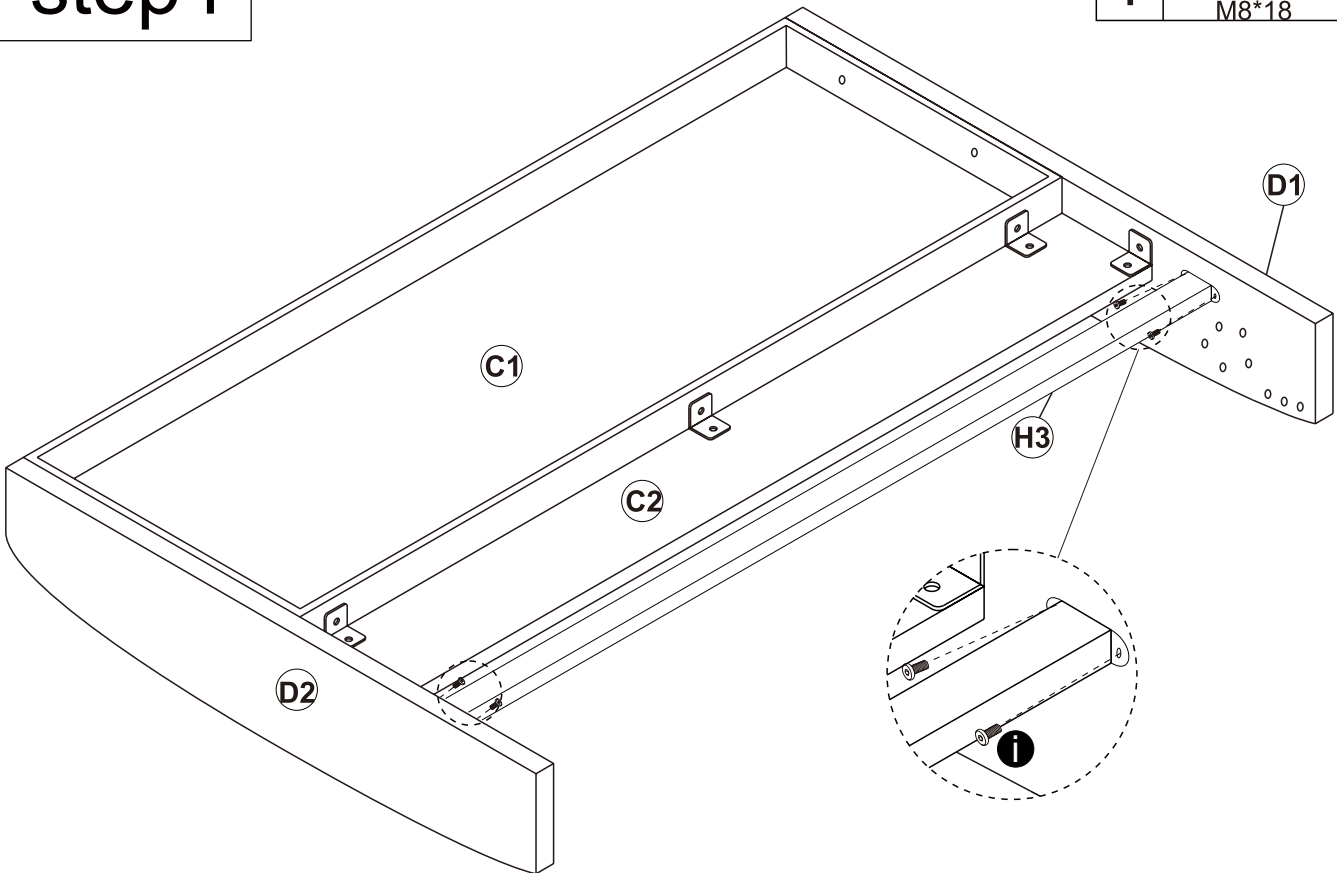

Hole H3 is facing downwards.

step5

Tighten the bolts that were pre-screwed to 80% in Step 19.

b

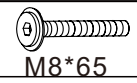

6PCS

D1

D2

P6 -Right

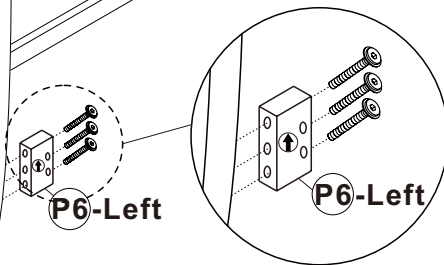

P6-Left

P6-Left

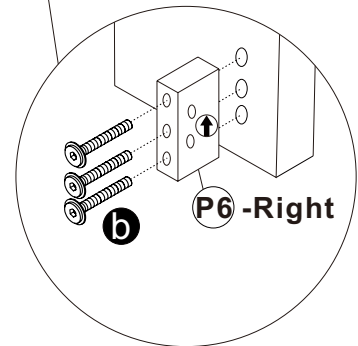

b

P6 -Right

80% pre-screwed.

step6

Tighten the bolts that were pre-screwed to 80% in Step 19.

g



2PCS

k



2PCS

D1

D2

L -Right

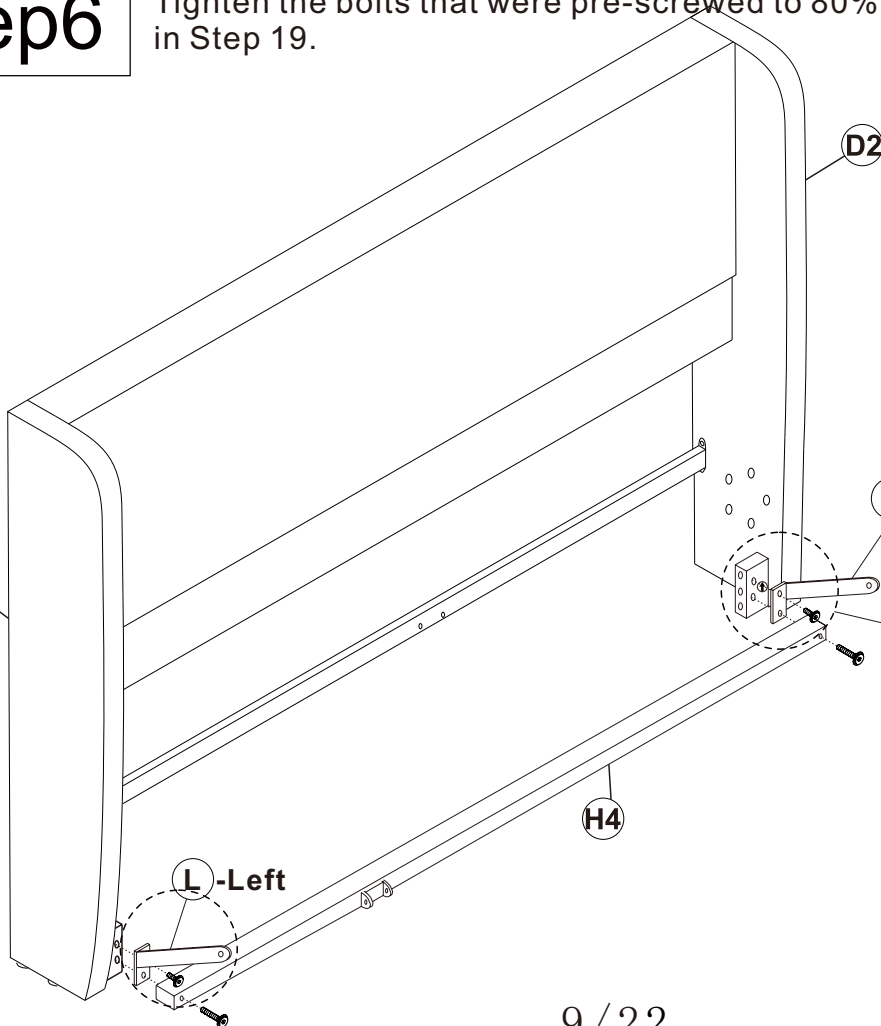

L -Left

H4

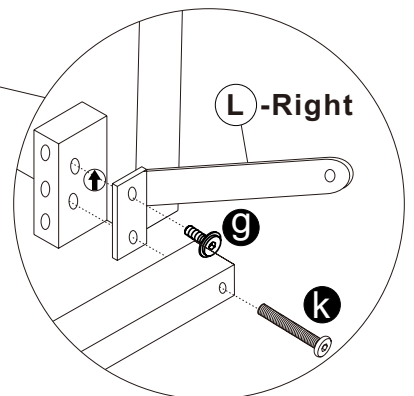

L -Right

g

k

80% pre-screwed.

step7

f

M8*18

4PCS

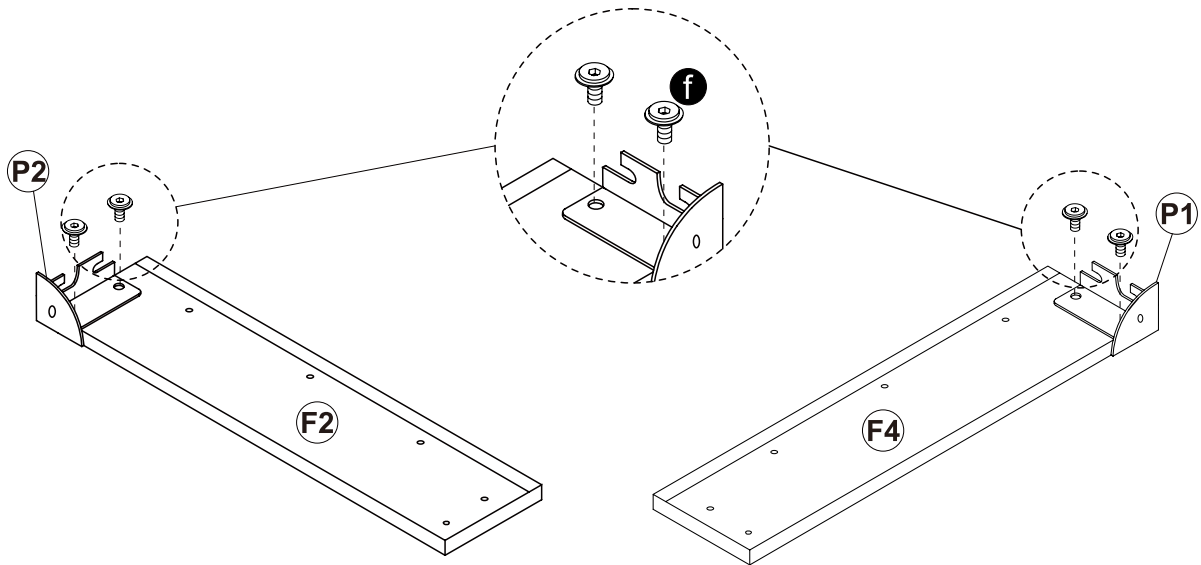

step8

f

M8*18

8PCS

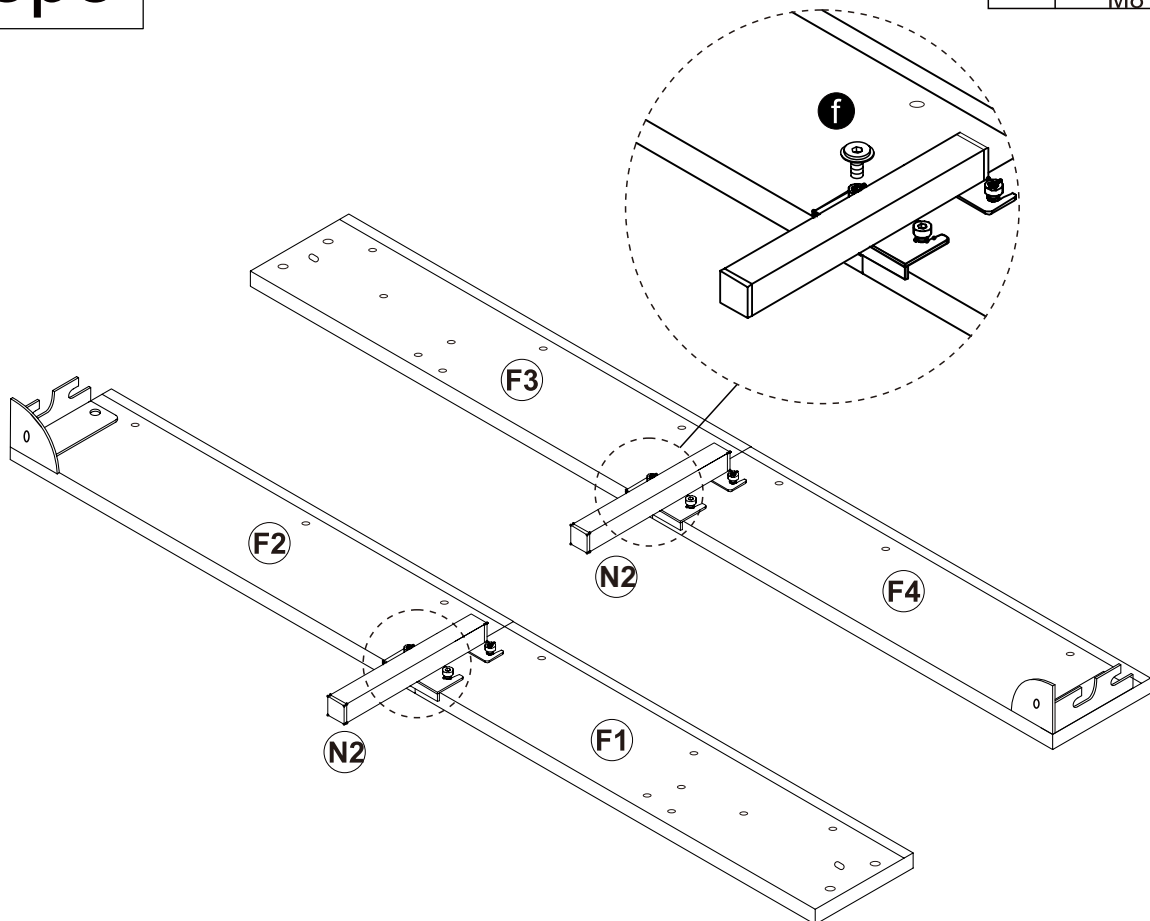

step9

f

M8*18

6PCS

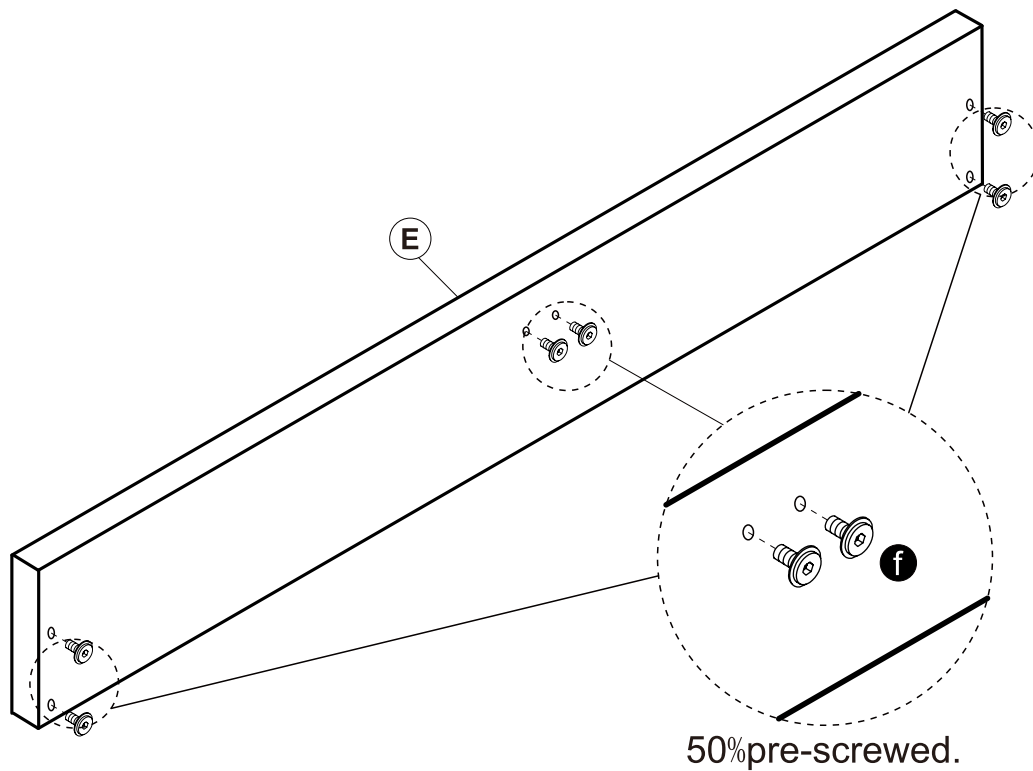

step10

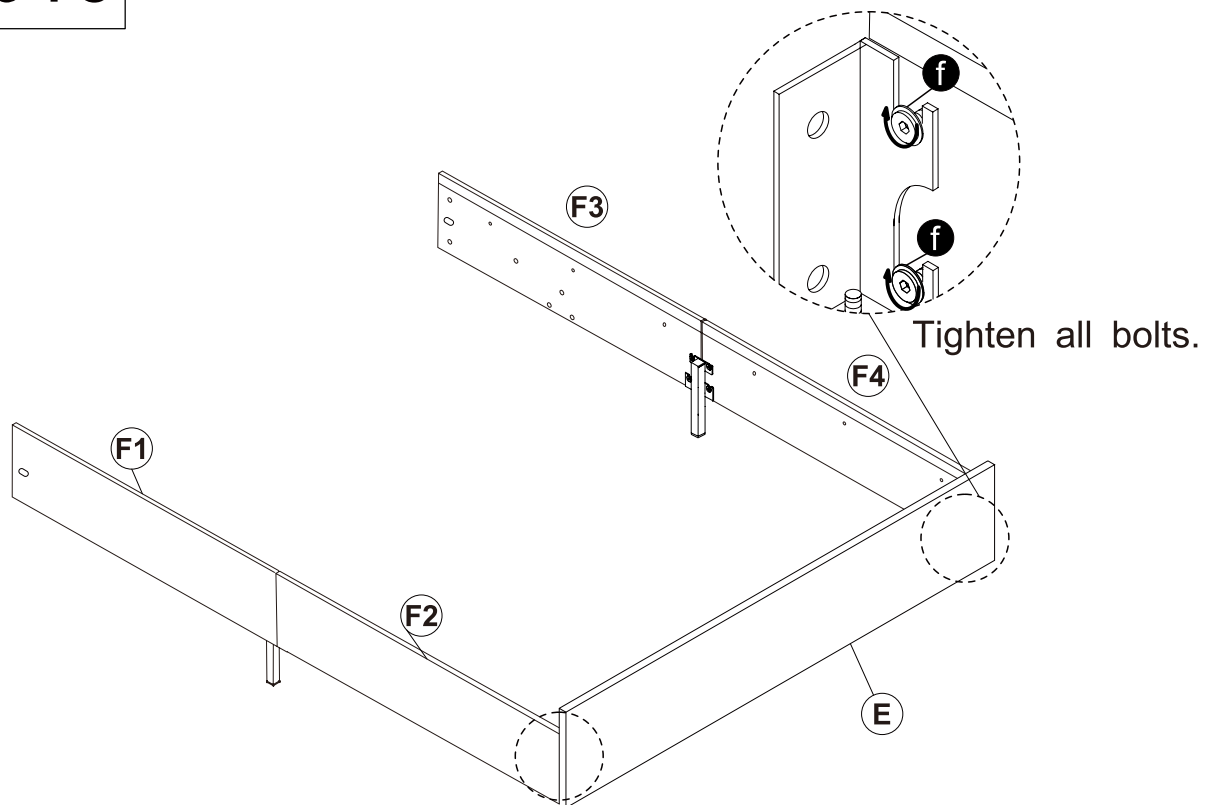

step11

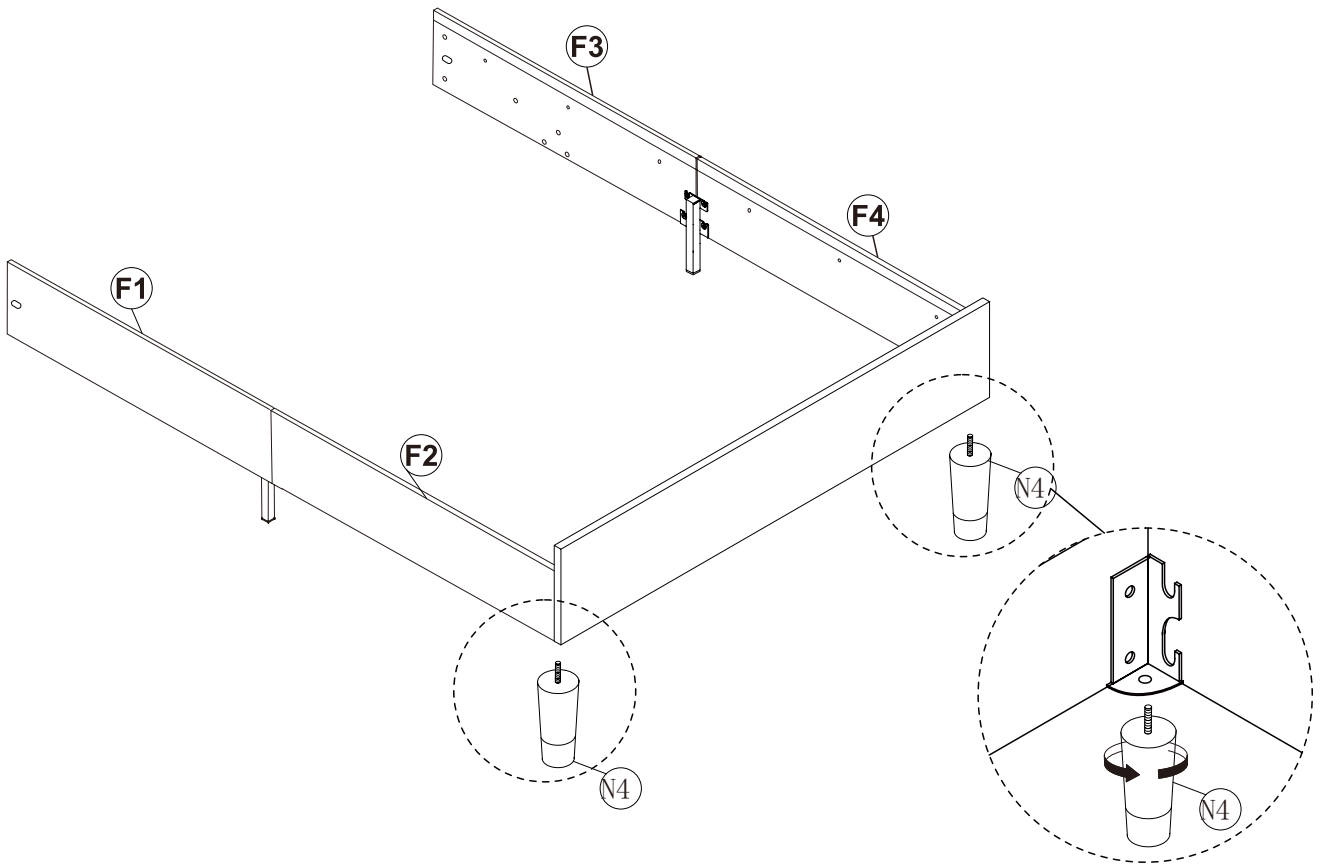

step12

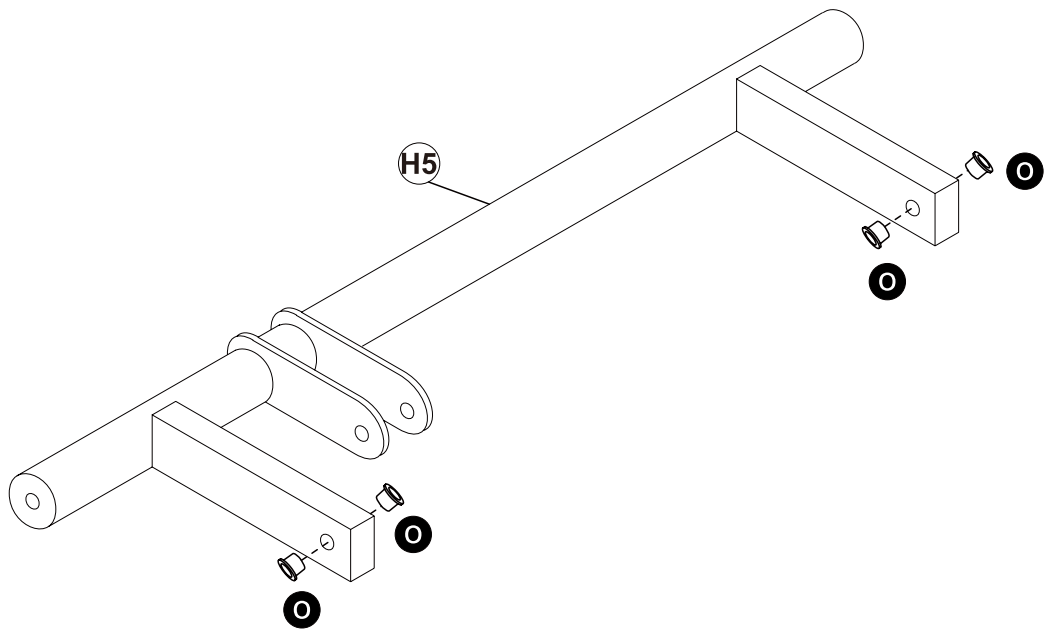

step13

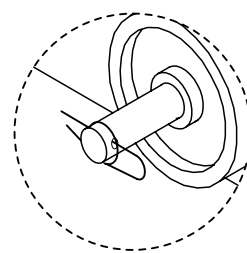
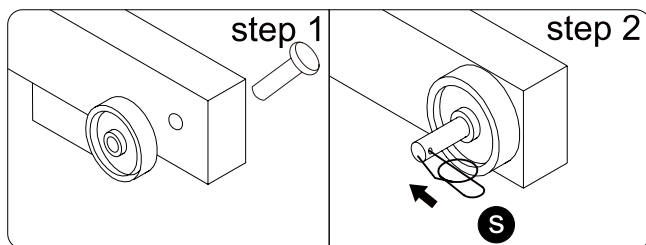
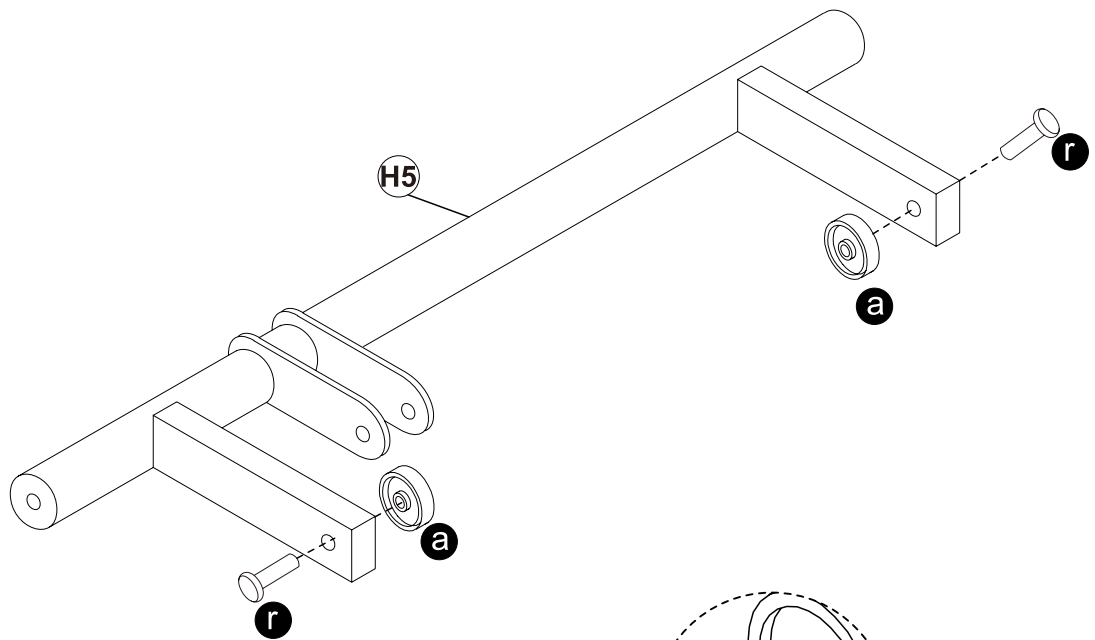

As shown on the graph, shows part S after assembling.

step14

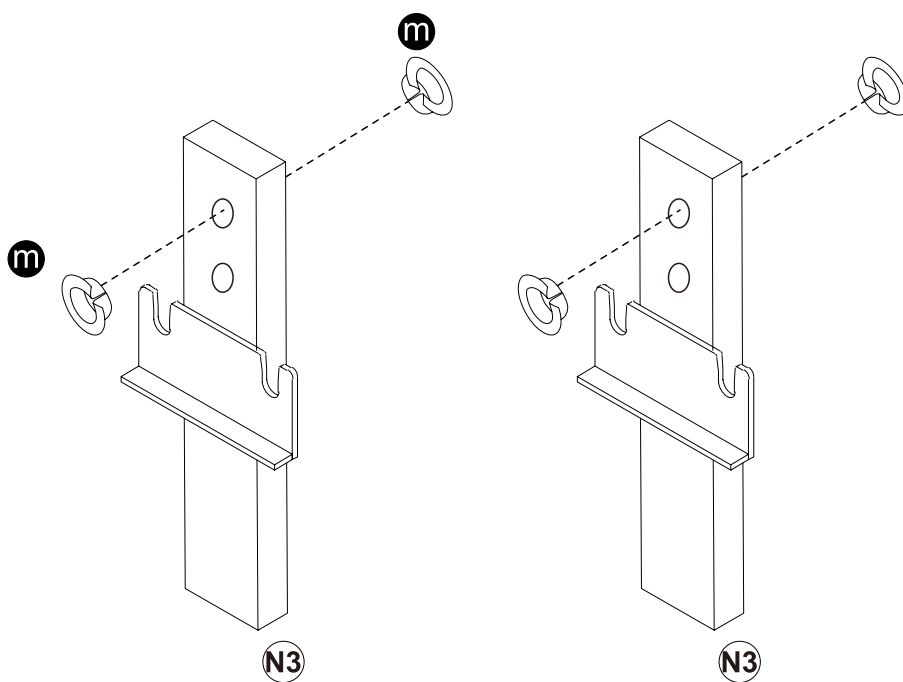

step15

j

M10*37

2PCS

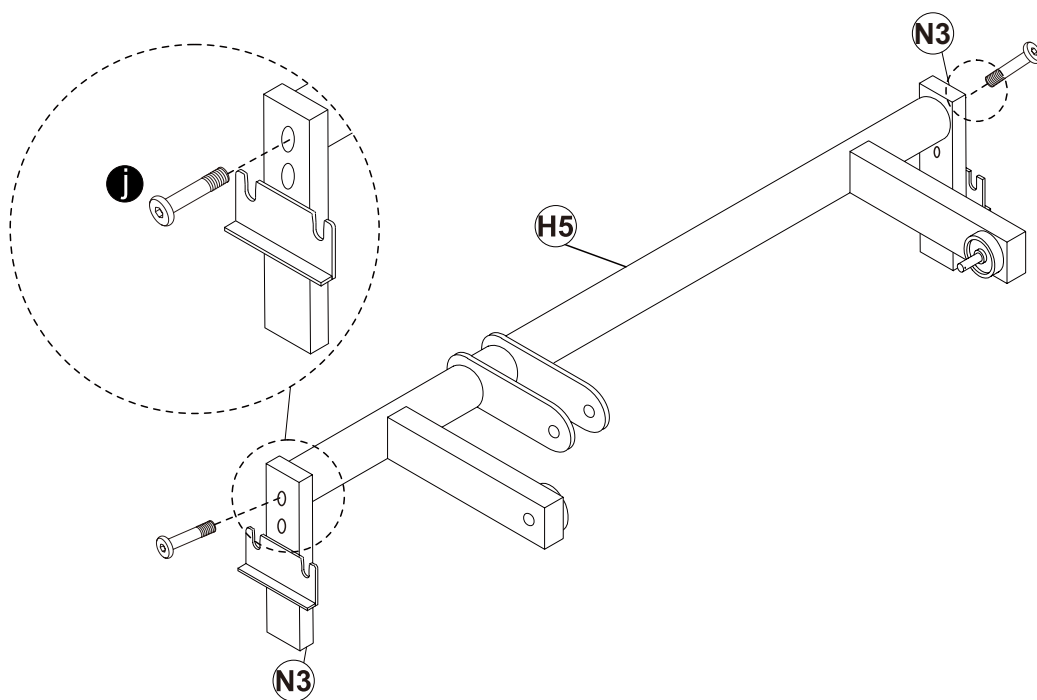

step16

i

M8*18

4PCS

g

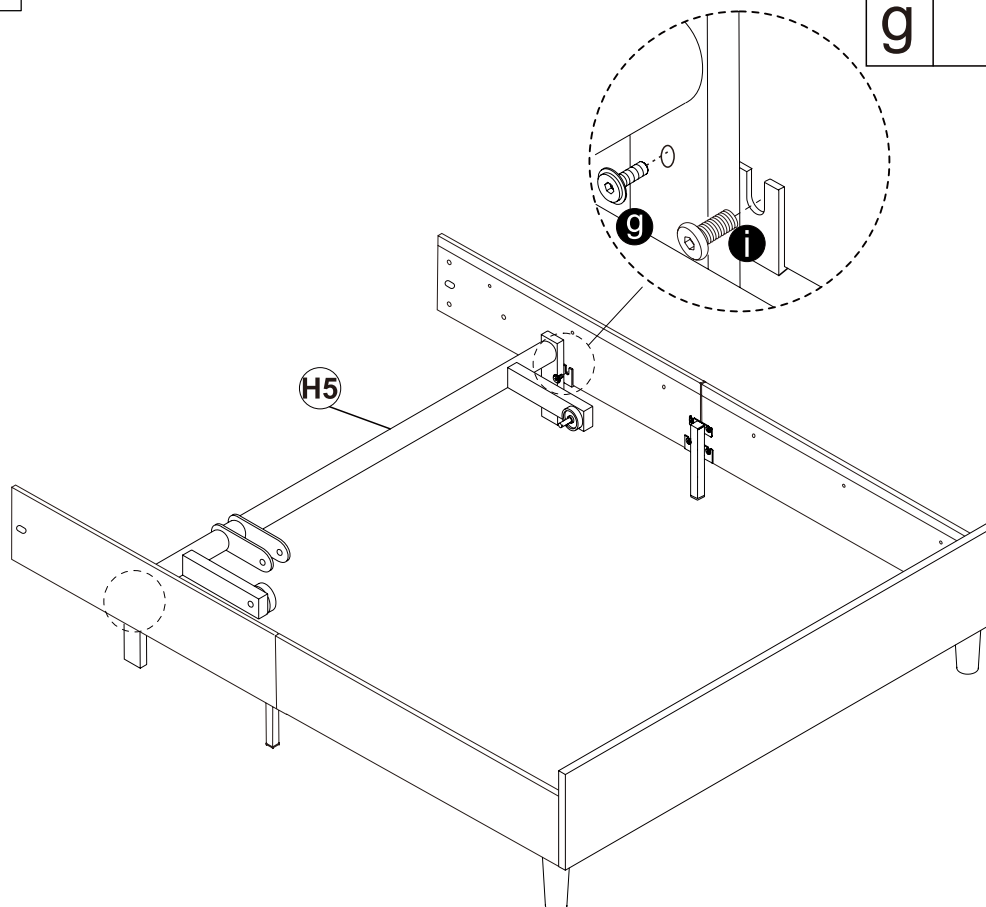

M8*35

2PCS

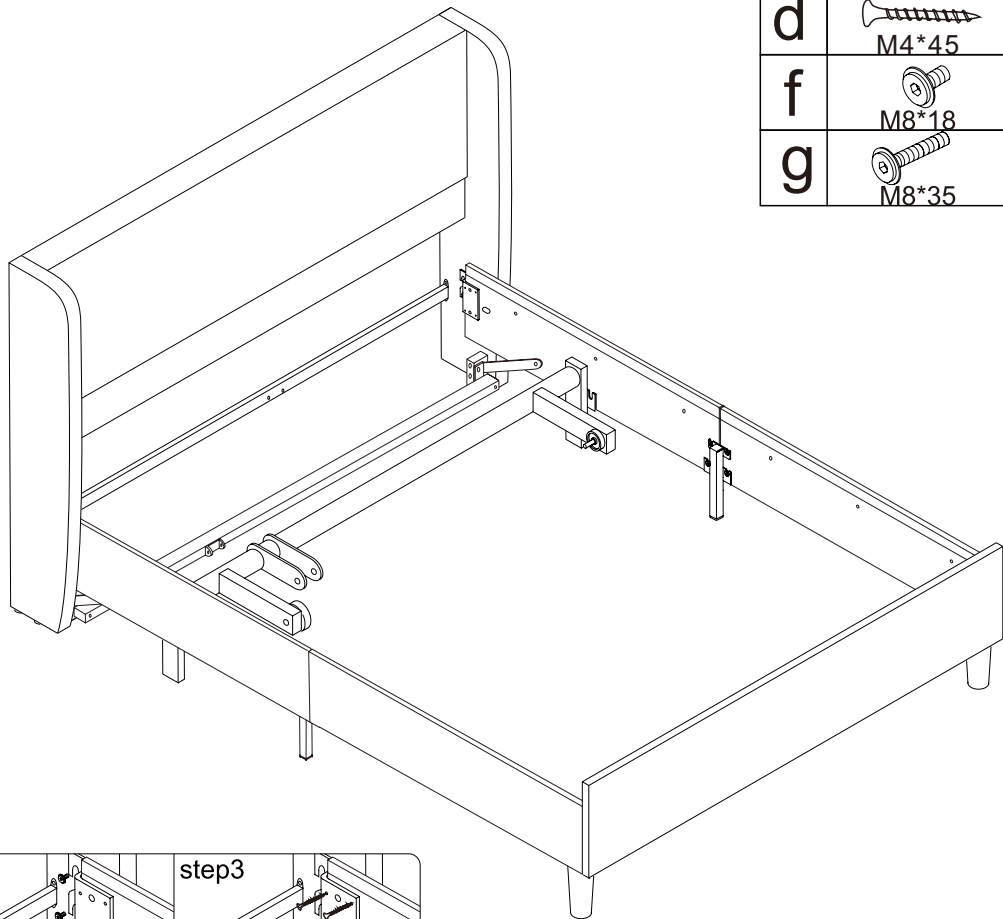

step17



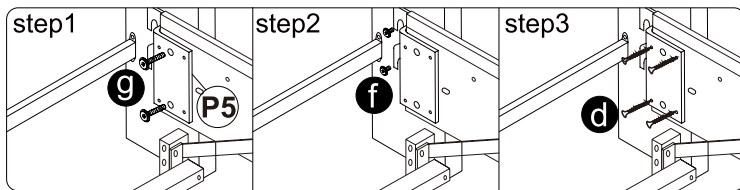

d	 M4*45	8PCS
f	 M8*18	4PCS
g	 M8*35	4PCS

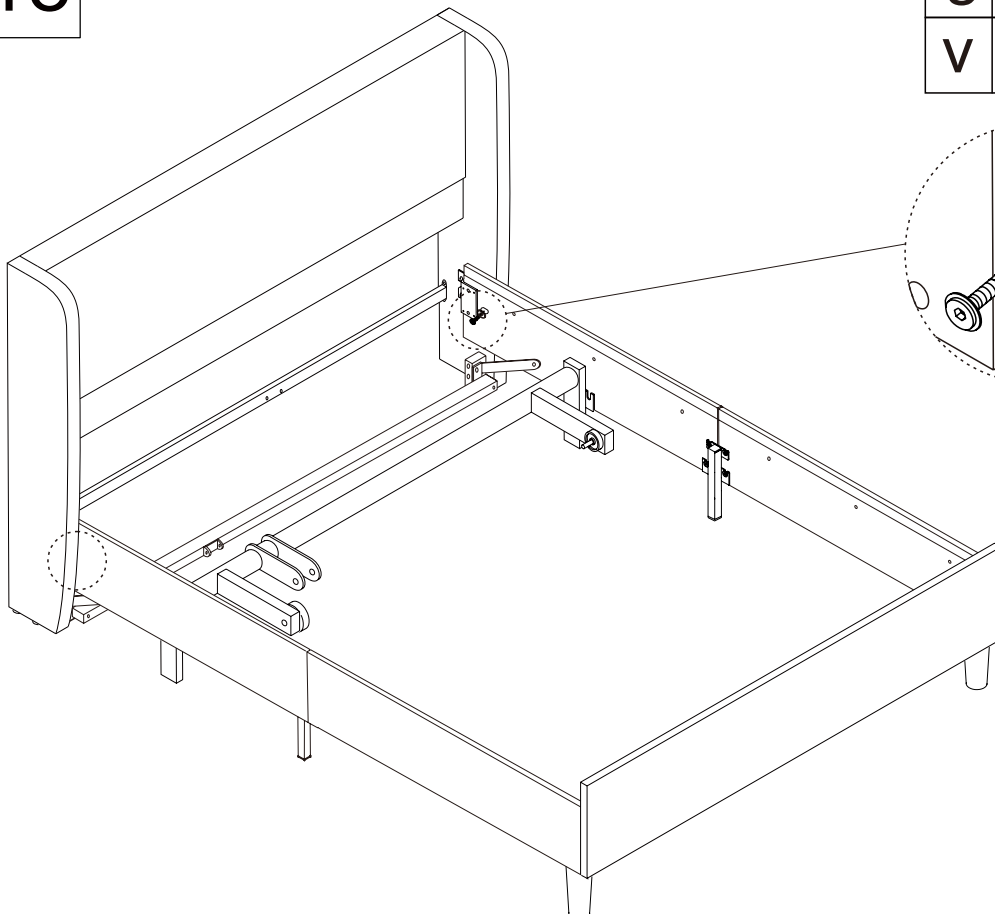

50%pre-screwed. Tighten all bolts.

step18



g	 M8*35	2PCS
v		2PCS

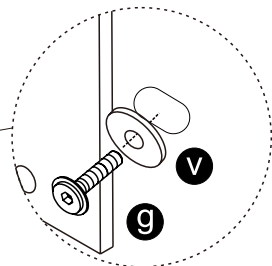

step 19

Tighten the bolts that were pre-screwed to 80% during this step.

f

M8*18

2PCS

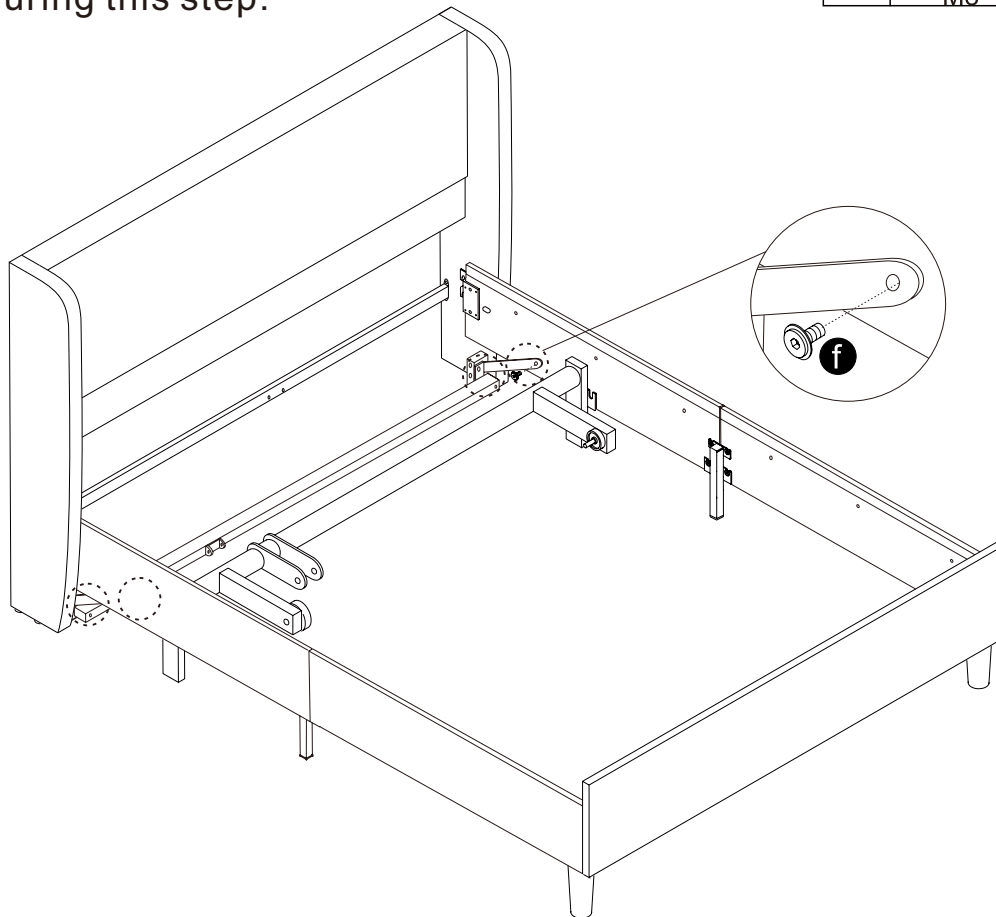

step 20

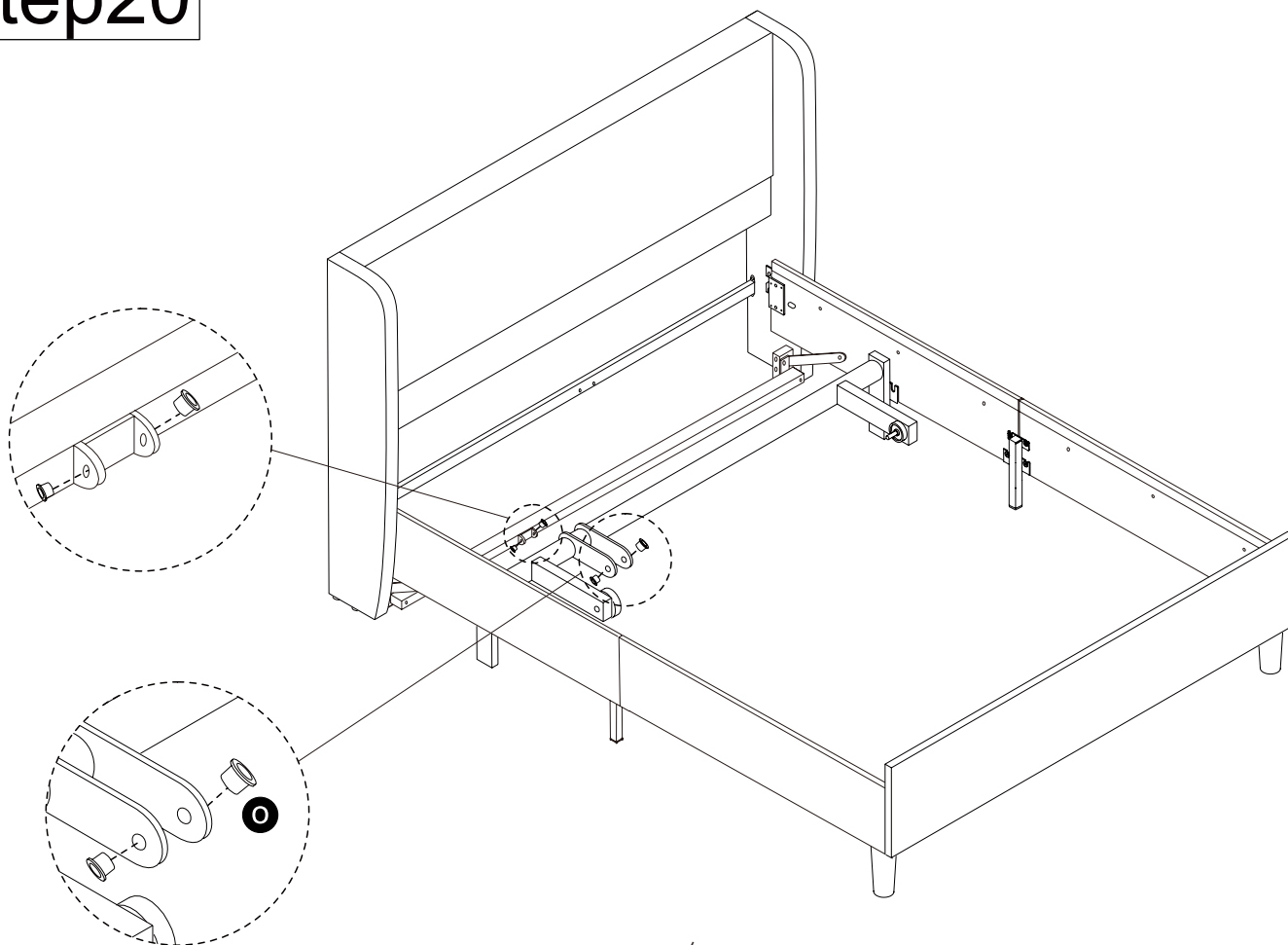

step21

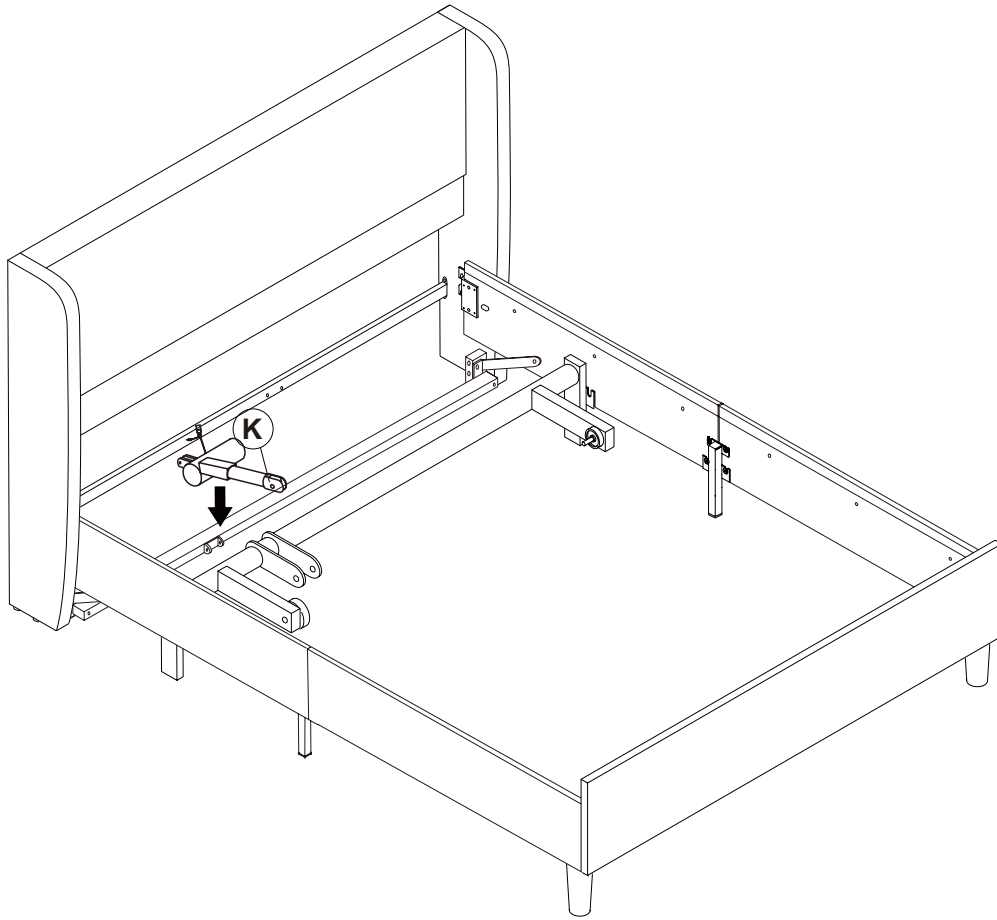

step22

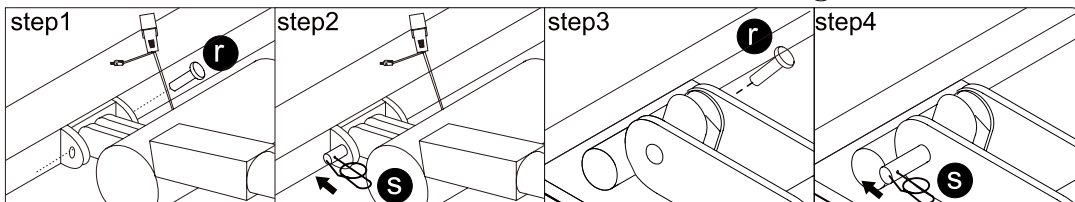
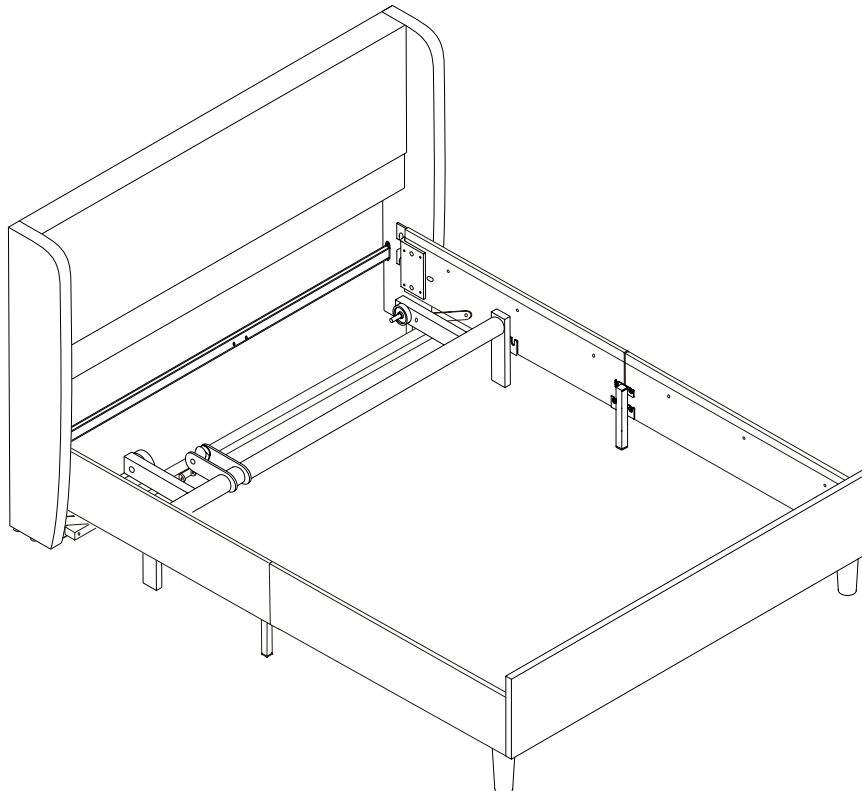

step25

f



2PCS

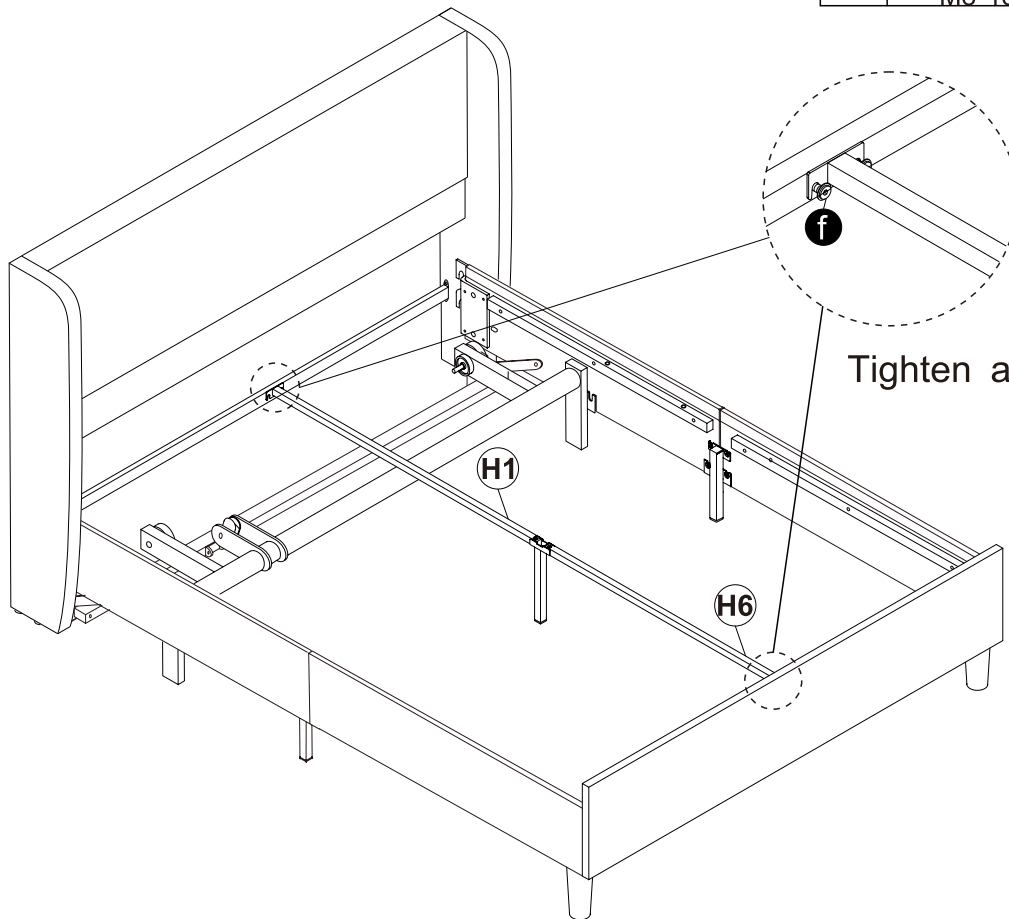

step26

g



3PCS

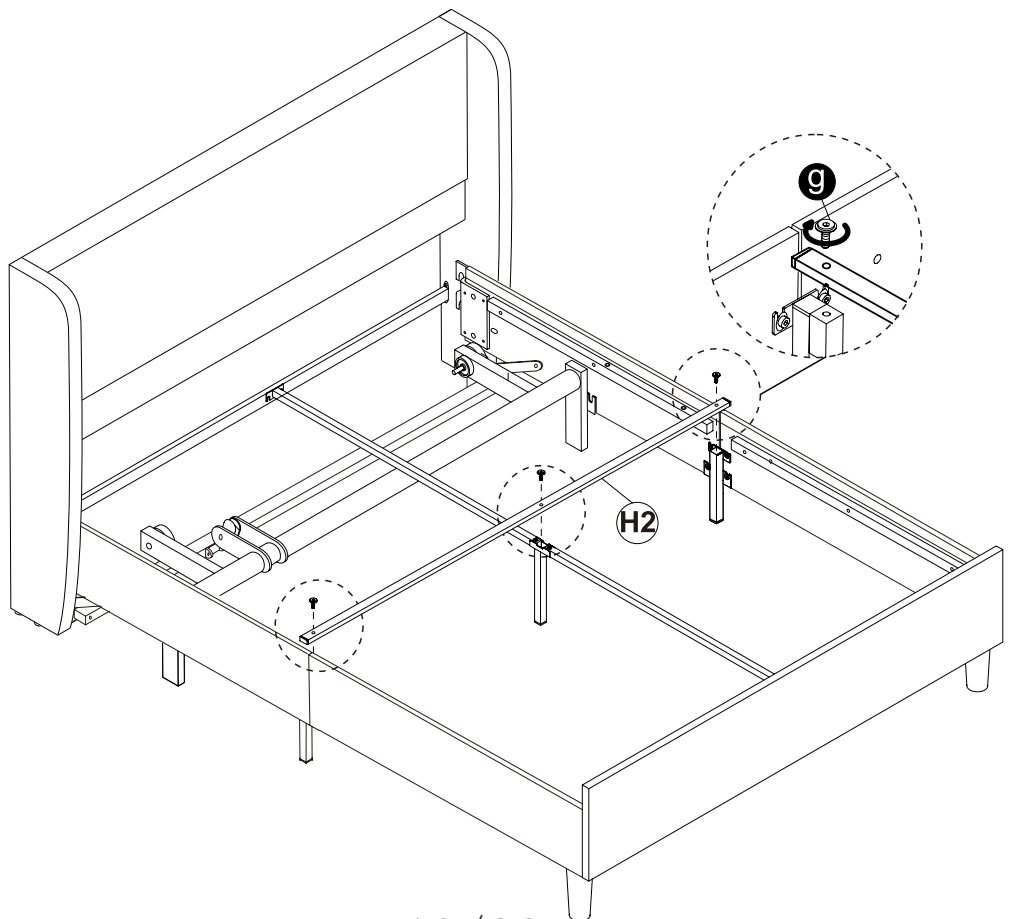

step27

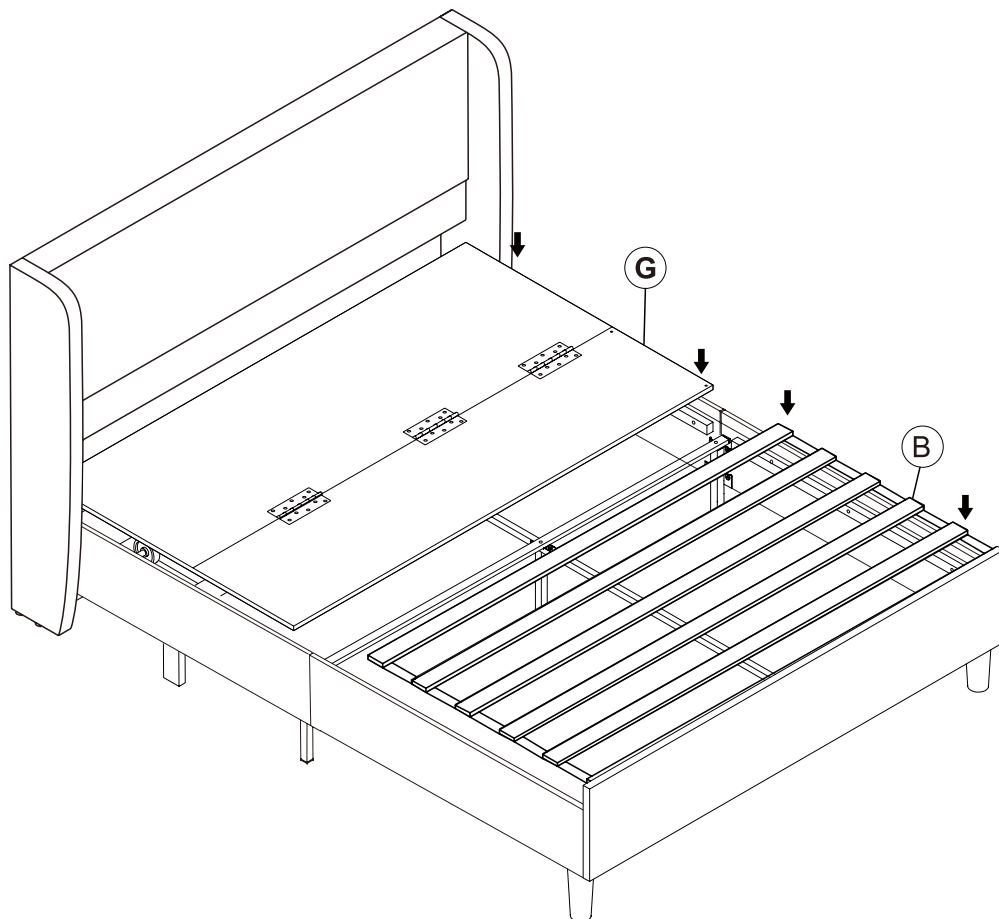

step28

e



4PCS

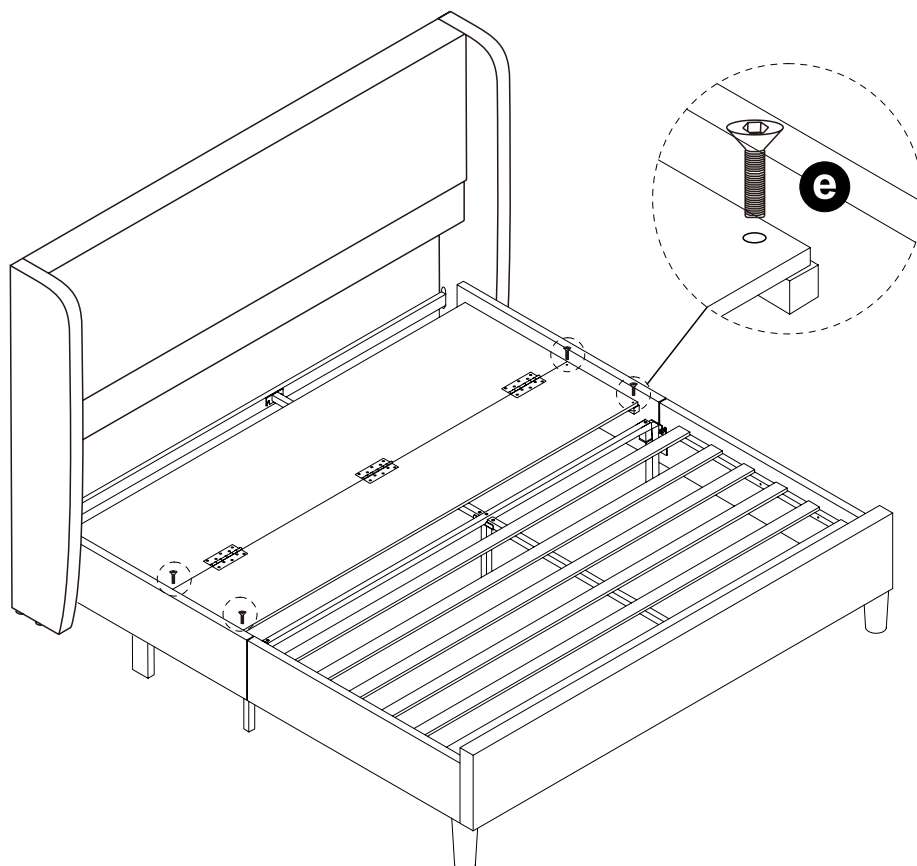

step29

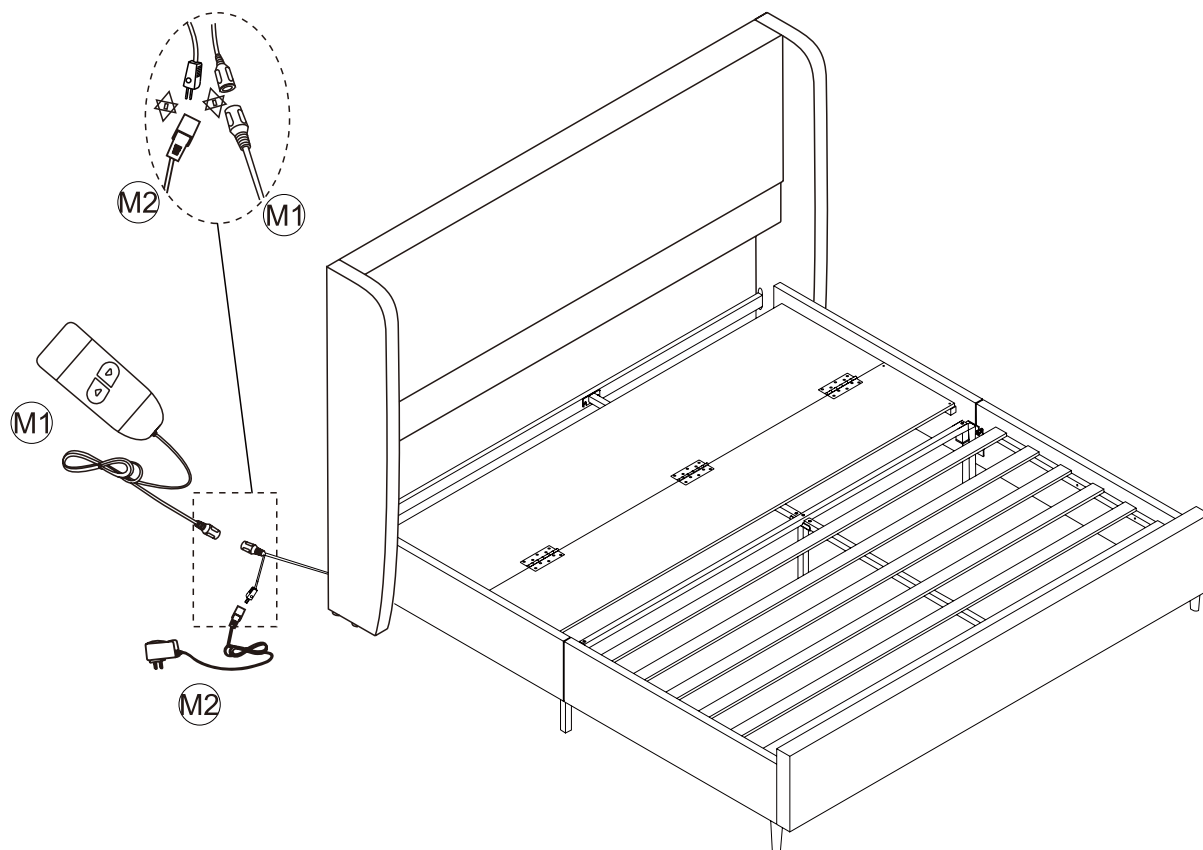

step30

Raise the bed plank.

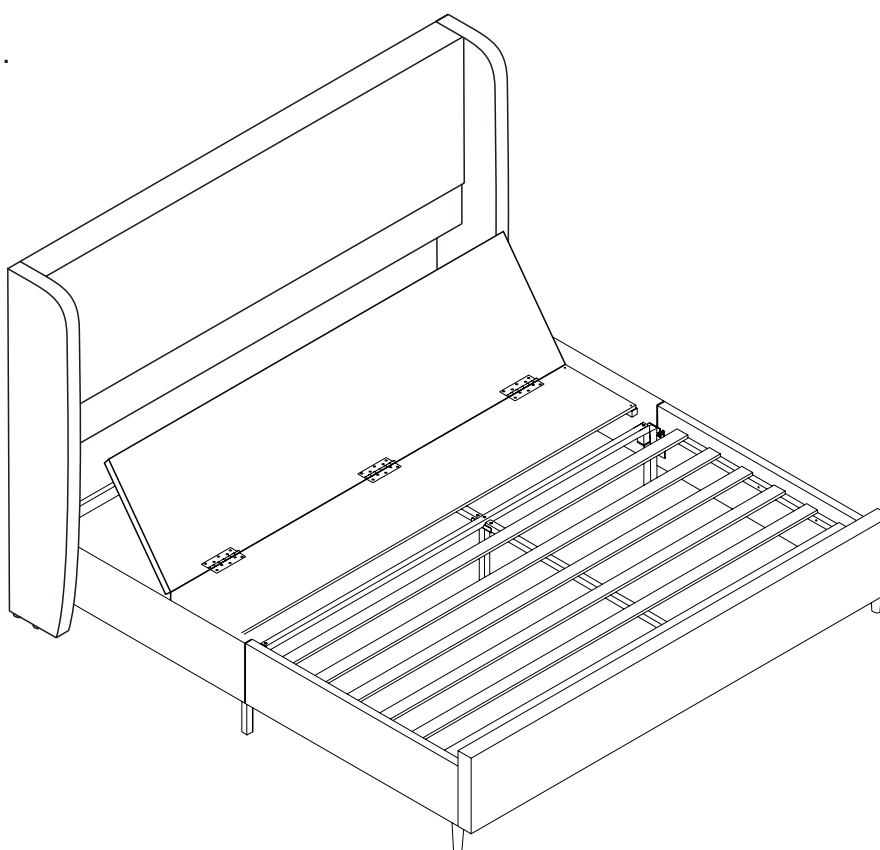
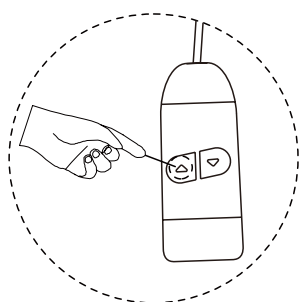

step31

Put down the bed plank.

