

Installationsanleitung/Installation Instruction/Instruction d'installation/
Istruzioni di installazione/Instrucciones de instalación/Installatie-instructies/
Installationsanvisningar/Instrukcje instalacji

KITCHEN ISLAND-N639P285034/N639P285035/N639P285036

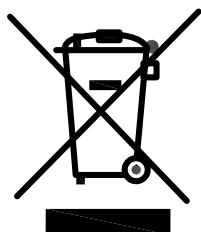

FR



Aous êtes responsable de remettre tous
les appareils électriques et électroniques
ueagés à des points de collecte
correspondants.

pour en savolr plus:
[www.quefalredemesdechts ,fr](http://www.quefalredemesdechts.fr)

DE: Unser Produkt wird Ihnen in 3 Paketen geliefert. Die Lieferzeiten dieser 3 Pakete können abweichen, bitte haben Sie etwas Geduld und vielen Dank für Ihr Verständnis.

UK: Our product will be delivered to you in 3 packages. The delivery times of these 3 packages may differ, please be patient and thank you for your understanding.

FR: Notre produit vous sera livré en 3 colis. Les délais de livraison de ces 3 colis peuvent différer, soyez patient et merci pour votre compréhension.

IT: Il nostro prodotto verrà consegnato in 3 pacchi. I tempi di consegna di questi 3 pacchi possono variare; vi preghiamo di avere un po' di pazienza e vi ringraziamo per la vostra comprensione.

ES: Nuestro producto se entregará en 3 paquetes. Los tiempos de entrega de estos 3 paquetes pueden variar; por favor, tenga un poco de paciencia y gracias por su comprensión.

NL: Ons product wordt in 3 pakketten bij u geleverd. De levertijden van deze 3 pakketten kunnen verschillen, we vragen om uw gedulden bedanken u voor uw begrip.

SE: Vår produkt kommer att levereras till dig i 3 paket. Leveranstiderna för dessa 3 paket kan variera, vi ber om ditt tålamod och tackar för din förståelse.

PL: Nasz produkt zostanie dostarczony w 3 paczkach. Czas dostawy tych 3 paczek może się różnić, prosimy o cierpliwość i dziękujemy za zrozumienie.

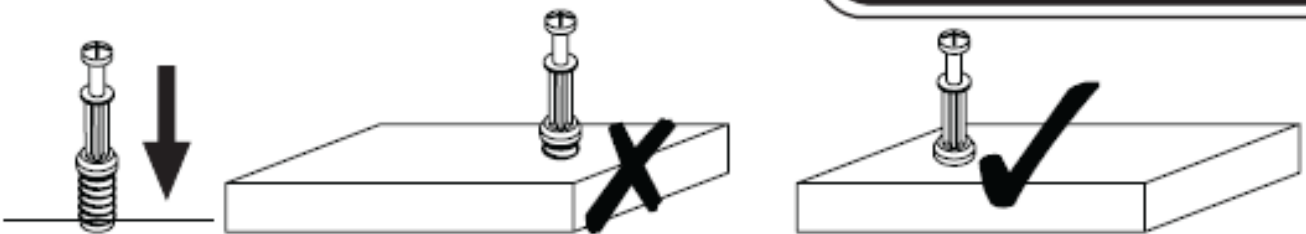

EN_QUICKFIT: Tighten quickfit until shoulder is flush with panel. Do not overtighten or undertighten.

FR_RACCORD RAPIDE: Faites serrer le raccord rapide jusqu'à ce que l'épaulement soit parfaitement encastré dans le panneau. Il ne faut ni trop serrer ni insuffisamment serrer.

ES_QUICKFIT: Apriete quickfit hasta que el hombro se descargue con el panel. NO lo sobreapriete ni lo apriete poco.

DE_QUICKFIT: Ziehen Sie den Quickfit fest, bis die Schulter mit der Platte bündig ist. Bitte nicht zu fest oder zu schwach anziehen.

IT_MONTAGGIO RAPIDO: Stringere il montaggio rapido fino a quando la spalla è a filo con il pannello, non stringere troppo o troppo poco.

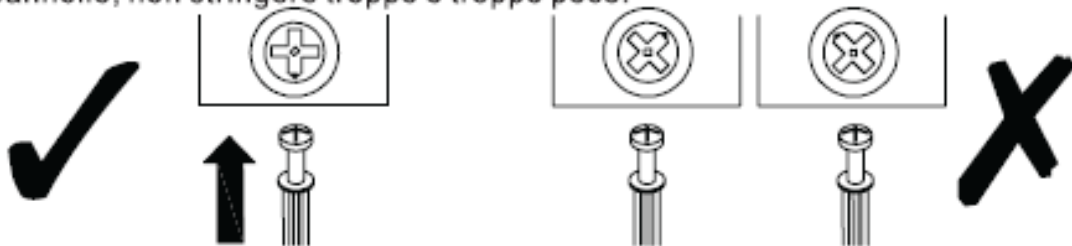

EN_CAM LOCK: When fitting cam lock, ensure starting position is correct before you insert connecting quickfit.

FR_SERRURE BATTEUSE: Avant d'insérer la serrure batteuse, veillez à la bonne orientation avant d'insérer le raccord rapide.

ES_CIERRE DE LA CÁMARA: Cuando instale el cierre de la cámara, asegúrese de que la posición de inicio es correcta antes de que inserte el quickfit conector.

DE_CAM-LOCK: Achten Sie bei der Montage des Cam-Locks auf die richtige Ausgangsposition, bevor Sie den Quickfit einsetzen.

IT_BLOCCAGGIO A CAMMA: Quando si monta il bloccaggio a camma, assicurarsi che la posizione iniziale sia corretta prima di inserire il montaggio rapido di collegamento.

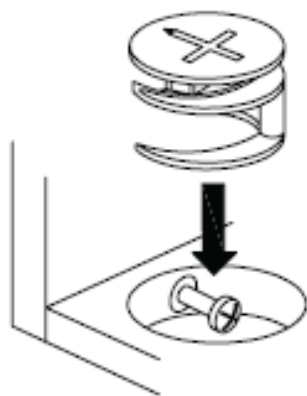

EN_Quickfit head should be in the centre of the cam lock when the two panels are joined.

Cam lock should be inserted before quickfit.

FR_Lorsque les deux panneaux sont assemblés, la tête du raccord rapide doit reposer au centre de la serrure batteuse.

Il faut insérer la serrure batteuse avant le raccord rapide.

ES_El cabezal del quickfit debe estar en el centro del cierre de la cámara cuando se unan los dos paneles.

Se debe insertar el cierre de la cámara antes que el quickfit.

DE_Der Quickfit-Kopf sollte sich in der Mitte des Cam-Locks befinden, wenn die beiden Platten zusammengefügt sind.

Der Cam-Lock sollte vor dem Quickfit eingesetzt werden.

IT_La testa del montaggio rapido deve trovarsi al centro del bloccaggio a camma quando i due pannelli sono uniti.

Il Bloccaggio a Camma deve essere inserito prima del montaggio rapido.

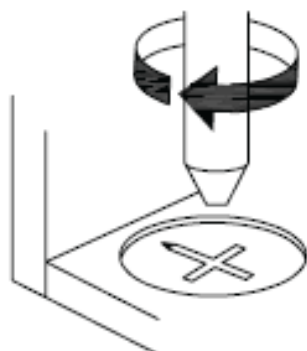

EN_Turn cam lock clockwise to tighten.

FR_Faites tourner la serrure batteuse dans le sens des aiguilles d'une montre pour la resserrer.

ES_Gire el cierre de la cámara en sentido horario para apretarlo.

DE_Drehen Sie den Cam-Lock im Uhrzeigersinn, um ihn festzuziehen.

IT_Ruotare il bloccaggio a camma in senso orario per stringere.

DE

1. Die maximale Tragfähigkeit der Oberplatte beträgt 60 kg, bitte nicht überladen.
2. Lassen Sie Kinder nicht auf Möbeln klettern, da dies zu Umstürzen und schweren Verletzungen führen kann.
3. Um die Sicherheit zu gewährleisten, installieren Sie bitte gemäß der Anleitung und ziehen Sie bei Bedarf Fachleute hinzu.
4. Stellen Sie Möbel nicht in die Nähe von Feuerquellen oder heißen Gegenständen, um Brandgefahr zu vermeiden.
5. Stellen Sie Möbel nicht in feuchten Umgebungen auf, um Materialschäden zu verhindern.
6. Überprüfen Sie regelmäßig alle Verbindungs- und Befestigungselemente, um sicherzustellen, dass sie fest sitzen und Unfälle zu vermeiden.
7. Dieses Produkt ist mit einem Kipp-Schutz ausgestattet, installieren Sie diesen Schutz, um Verletzungen durch Umstürzen zu vermeiden.

UK

1. The maximum weight capacity of the top panel is 60kg; please do not overload.
2. Do not allow children to climb on furniture, as this may cause tipping and serious injury.
3. To ensure safety, please install correctly according to the instructions and seek professional assistance if necessary.
4. Do not place furniture near fire sources or hot objects to avoid fire hazards.
5. Do not place furniture in damp environments to prevent material damage.
6. Regularly check all connectors and fasteners to ensure they are secure to prevent accidents.
7. This product comes with a anti-tipping device; install this device to prevent injuries from tipping.

FR

1. La charge maximale du panneau supérieur est de 60 kg, ne pas surcharge.
2. Ne laissez pas les enfants grimper sur les meubles, cela peut entraîner des basculements et des blessures graves.
3. Pour garantir la sécurité, installez correctement selon les instructions et demandez l'aide de professionnels si nécessaire.
4. Ne placez pas les meubles près de sources de chaleur ou d'objets chauds pour éviter les risques d'incendie.
5. Ne placez pas les meubles dans des environnements humides pour éviter d'endommager les matériaux.
6. Vérifiez régulièrement tous les connecteurs et les fixations pour vous assurer qu'ils sont bien serrés et éviter les accidents.
7. Ce produit est équipé d'un dispositif anti-basculement; installez ce dispositif pour éviter les blessures dues au basculement.

IT

1. La capacità massima del pannello superiore è di 60 kg; non sovraccaricare.
2. Non permettere ai bambini di arrampicarsi sui mobili, poiché ciò può causare ribaltamenti e gravi infortuni.
3. Per garantire la sicurezza, installare correttamente secondo le istruzioni e, se necessario, chiedere assistenza a professionisti.
4. Non posizionare i mobili vicino a fonti di calore o oggetti caldi per evitare rischi di incendio.
5. Non posizionare i mobili in ambienti umidi per prevenire danni ai materiali.
6. Controllare regolarmente tutti i connettori e le viti per assicurarsi che siano saldi e prevenire incidenti.
7. Questo prodotto è dotato di un dispositivo anti-ribaltamento; installare questo dispositivo per evitare infortuni da ribaltamento.

ES

1. La capacidad máxima del panel superior es de 60 kg; no sobrecargar.
2. No permita que los niños escalen los muebles, ya que esto puede causar volcaduras y lesiones graves.
3. Para garantizar la seguridad, instale correctamente según las instrucciones y busque ayuda profesional si es necesario.
4. No coloque los muebles cerca de fuentes de fuego u objetos calientes para evitar riesgos de incendio.
5. No coloque los muebles en ambientes húmedos para evitar daños en los materiales.
6. Revise regularmente todos los conectores y sujetadores para asegurarse de que estén seguros y prevenir accidentes.
7. Este producto viene con un dispositivo anti-vuelco; instale este dispositivo para prevenir lesiones por vuelcos.

NL

1. De maximale draagcapaciteit van het bovenpaneel is 60 kg; niet overbelasten.
2. Laat kinderen niet op meubels klimmen, dit kan leiden tot omvallen en ernstige verwondingen.
3. Installeer correct volgens de instructies om de veiligheid te waarborgen, en schakel indien nodig professionele hulp in.
4. Plaats meubels niet in de buurt van vuurbronnen of warme objecten om brandgevaar te voorkomen.
5. Plaats meubels niet in vochtige omgevingen om materiaalschade te voorkomen.
6. Controleer regelmatig alle verbindingen en bevestigingsmiddelen om ervoor te zorgen dat ze stevig zijn en om ongevallen te voorkomen.
7. Dit product is uitgerust met een kantelbeveiliging; installeer dit apparaat om verwondingen door omvallen te voorkomen.

SE

1. Den maximala viktkapaciteten för överpanelen är 60 kg; överbelasta inte.
2. Låt inte barn klättra på möbler, då detta kan orsaka tippning och allvarliga skador.
3. För att säkerställa säkerheten, installera korrekt enligt instruktionerna och sök professionell hjälp om det behövs.
4. Placera inte möbler nära eldkällor eller heta föremål för att undvika brandrisk.
5. Placera inte möbler i fuktiga miljöer för att förhindra skador på materialen.
6. Kontrollera regelbundet alla kopplingar och fästelement för att säkerställa att de är säkra för att förhindra olyckor.
7. Denna produkt levereras med en anti-tippanordning; installera denna anordning för att förhindra skador vid tippning.

PL

1. Maksymalne obciążenie górnej płyty wynosi 60 kg; nie przeciążaj.
2. Nie pozwól dzieciom wspiąć się na meble, ponieważ może to prowadzić do przewrócenia się i poważnych obrażeń.
3. Aby zapewnić bezpieczeństwo, zainstaluj prawidłowo zgodnie z instrukcją i w razie potrzeby skorzystaj z pomocy profesjonalistów.
4. Nie stawiaj mebli w pobliżu źródeł ognia lub gorących przedmiotów, aby uniknąć ryzyka pożaru.
5. Nie stawiaj mebli w wilgotnych środowiskach, aby zapobiec uszkodzeniu materiałów.
6. Regularnie sprawdzaj wszystkie złącza i elementy mocujące, aby upewnić się, że są stabilne i aby zapobiec wypadkom.
7. Produkt ten jest wyposażony w urządzenie zapobiegające przewróceniu; zainstaluj to urządzenie, aby uniknąć obrażeń w wyniku przewrócenia.

Ausstattung der Komponenten

Bitte überprüfen Sie, ob Sie alle unten aufgeführten Teile haben. Hinweis: Die unten angegebenen Mengen sind die korrekte Menge, um die Montage zu vervollständigen. In einigen Fällen können mehr Beschläge geliefert werden, als benötigt werden.

Components fittings

Please check you have all the panels listed below. Note, The quantities below are the correct amount to complete the assembly. in some cases more fittings may be supplied than are required

Accessoires des composants

Veillez vérifier que vous disposez de tous les panneaux énumérés ci-dessous. Remarque : les quantités indiquées ci-dessous correspondent à la quantité nécessaire pour compléter l'assemblage. Dans certains cas, il se peut que le nombre de raccords fournis soit supérieur au nombre de raccords nécessaires.

Componenti di fissaggio

Verificare di disporre di tutti i pannelli elencati di seguito. Nota: le quantità indicate di seguito sono quelle corrette per completare l'assemblaggio. In alcuni casi possono essere forniti più raccordi di quelli necessari.

Componentes

Compruebe que dispone de todos los paneles que se indican a continuación. Nota: las cantidades indicadas a continuación son las necesarias para completar el montaje. En algunos casos, es posible que se suministren más accesorios de los necesarios.

Onderdelen

Controleer of je alle hieronder vermelde panelen hebt. Let op: de onderstaande hoeveelheden zijn de juiste hoeveelheid om de assemblage te voltooien. in sommige gevallen kan er meer beslag worden geleverd dan nodig is.

Komponenter beslag

Kontrollera att du har alla paneler som anges nedan. Notera, kvantiteterna nedan är den korrekta mängden för att slutföra monteringen. i vissa fall kan fler beslag levereras än vad som krävs.

Elementy wyposażenia

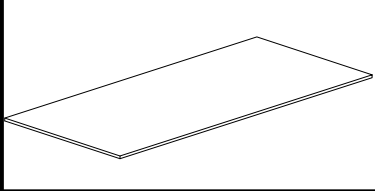
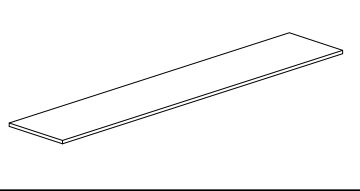
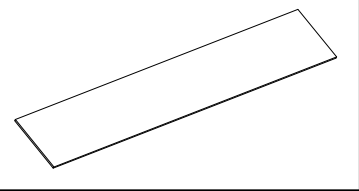
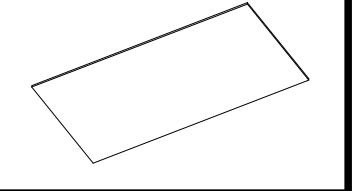
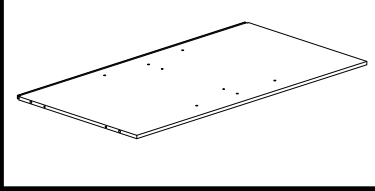
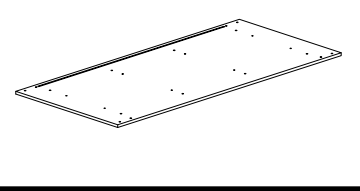
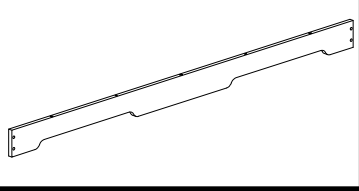

Sprawdź, czy masz wszystkie panele wymienione poniżej. Uwaga: Poniższe ilości są prawidłowe do ukończenia montażu. W niektórych przypadkach może być dostarczonych więcej elementów niż jest to wymagane.

N639P285034-BOX:1/3



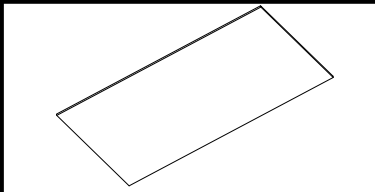
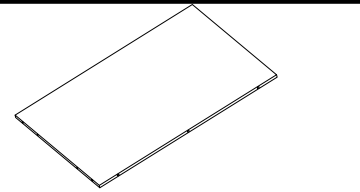
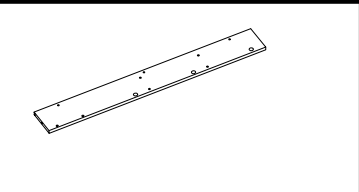
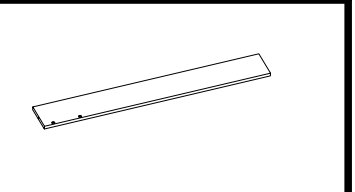
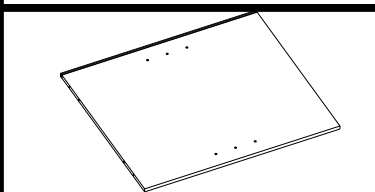
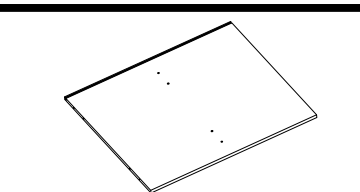
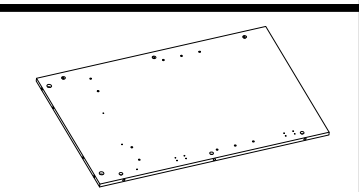
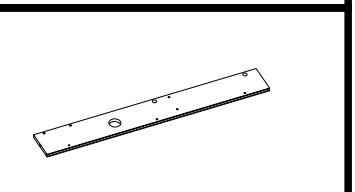
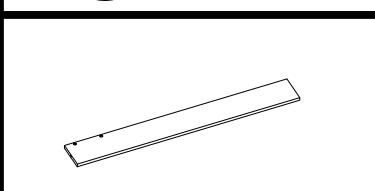
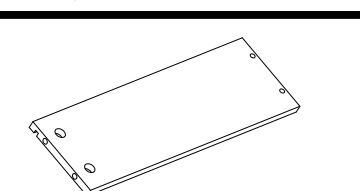
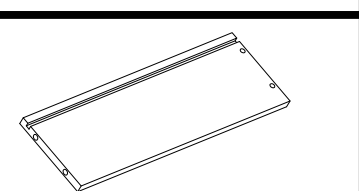
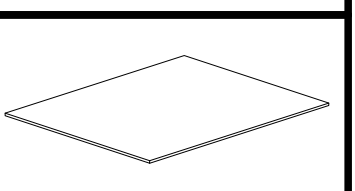

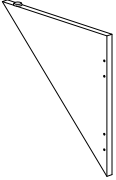
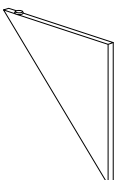
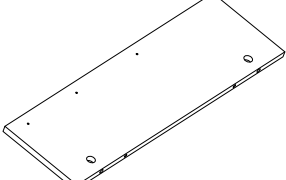
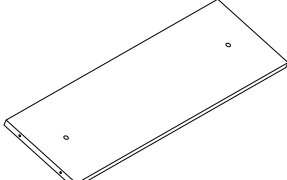
| | | | |
|--|---|--|---|
|  |  |  |  |
| ① x1pc | ② x1pc | ⑤ x1pc | ⑥ x2pcs |
|  |  |  | |
| ⑧ x1pc | ②⑥ x1pc | ②⑦ x2pcs | |

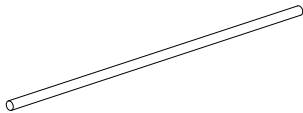
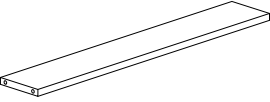
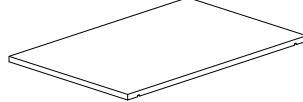
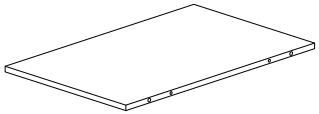
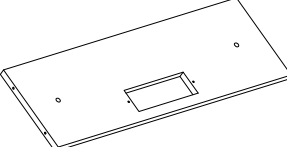
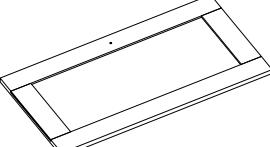
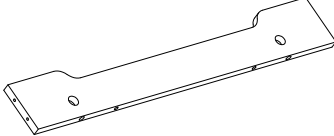
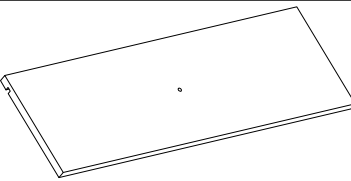
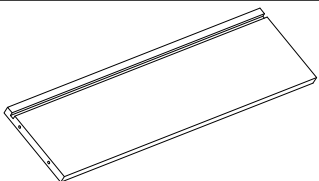
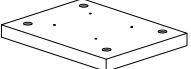

N639P285035-BOX:2/3

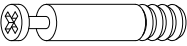
| | | | |
|--|---|--|---|
|  |  |  |  |
| ⑦ x1pc | ⑩ x1pc | ⑪ x1pc | ⑫ x1pc |
|  |  |  |  |
| ⑱ x1pc | ⑳ x1pc | ㉑ x1pc | ㉒ x1pc |
|  |  |  |  |
| ㉓ x1pc | ㉔ x2pcs | ㉕ x2pcs | ㉖ x2pcs |

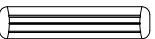
| | | | |
|--|---|--|---|
|  |  |  |  |
| ③ x 1pc | ④ x 1pc | ⑨ x 1pc | ⑬ x 1pc |
|  |  |  |  |
| ⑭ x 2pcs | ⑮ x 5pcs | ⑯ x 3pcs | ⑰ x 2pcs |
|  |  |  |  |
| ⑲ x 1pc | ⑳ x 1pc | ㉕ x 2pcs | ㉘ x 2pcs |
|  |  |  | |
| ㉙ x 2pcs | ㉚ x 2pcs | ㉜ x 5pcs | |

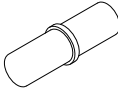
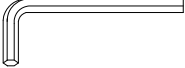
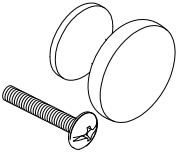
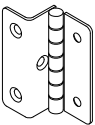
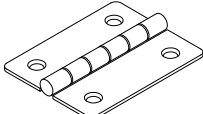
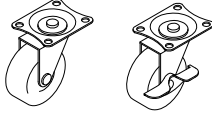
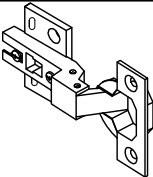
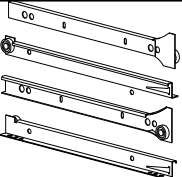
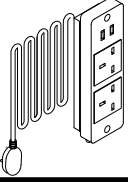
Hardware List:N639P285036-BOX:3/3

| | | | | |
|---|---|---|---|---|
|  $\phi 15 \times 10 \text{mm}$ |  $\phi 6 \times 34 \text{mm}$ |  $M5 \times 38 \text{mm}$ |  $\phi 3.5 \times 12 \text{mm}$ |  $\phi 6 \times 30 \text{mm}$ |
| A x50pcs | B x50pcs | C x46pcs | D x78pcs | E x46pcs |
|  $\phi 1/4 \times 23 \text{mm}$ |  $\phi 4 * 15 \text{mm}$ |  |  $M4$ |  |
| F x24pcs | G x20pcs | H x8pcs | I x1pc | J x4pcs |
|  |  | $\times 3$ $\times 2$  |  |  CL DL CR DR |
| K x4pcs | L x3pcs | M x5pcs | N x4pcs | O x2pcs |
|  | | | | |
| P x1pc | | | | |

| | |
|--|--|
|  ø3.5x12mm |  ø4x15mm |
| D x78pcs | G x20pcs |

DE: Bitte beachten Sie, dass die Formen der Schrauben D und G ähnlich sind.

Bitte installieren Sie entsprechend der Anleitung und unterscheiden Sie sie!

UK: Please note that the shapes of screws D and G are similar. Please install according to the instructions and distinguish them!

FR: Notez que les vis D et G ont des formes similaires.

Veillez les installer en suivant les instructions pour les séparer!

IT: Si prega di notare che le forme delle viti D e G sono simili. Si prega di installarle seguendo le istruzioni e di distinguerle!

ES: Por favor, tenga en cuenta que las formas de los tornillos G y D son similares. Por favor, instálelos de acuerdo con las instrucciones y distíngalos.

NL: Let op, de vormen van schroeven G en D zijn vergelijkbaar. Installeer volgens de instructies en maak onderscheid tussen ze!

SE: Observera att formerna på skruvarna G och D är lika.

Installera enligt anvisningarna och särskilj dem!

PL: Zauważ, że kształty śrub G i D są podobne.

Zainstaluj zgodnie z instrukcjami i rozróżnij je!

Installationsanleitung/Installation Instruction/Instruction d'installation/
 Istruzioni di installazione/Instrucciones de instalación/Installatie-instructies/
 Installationsanvisningar/Instrukcje instalacji

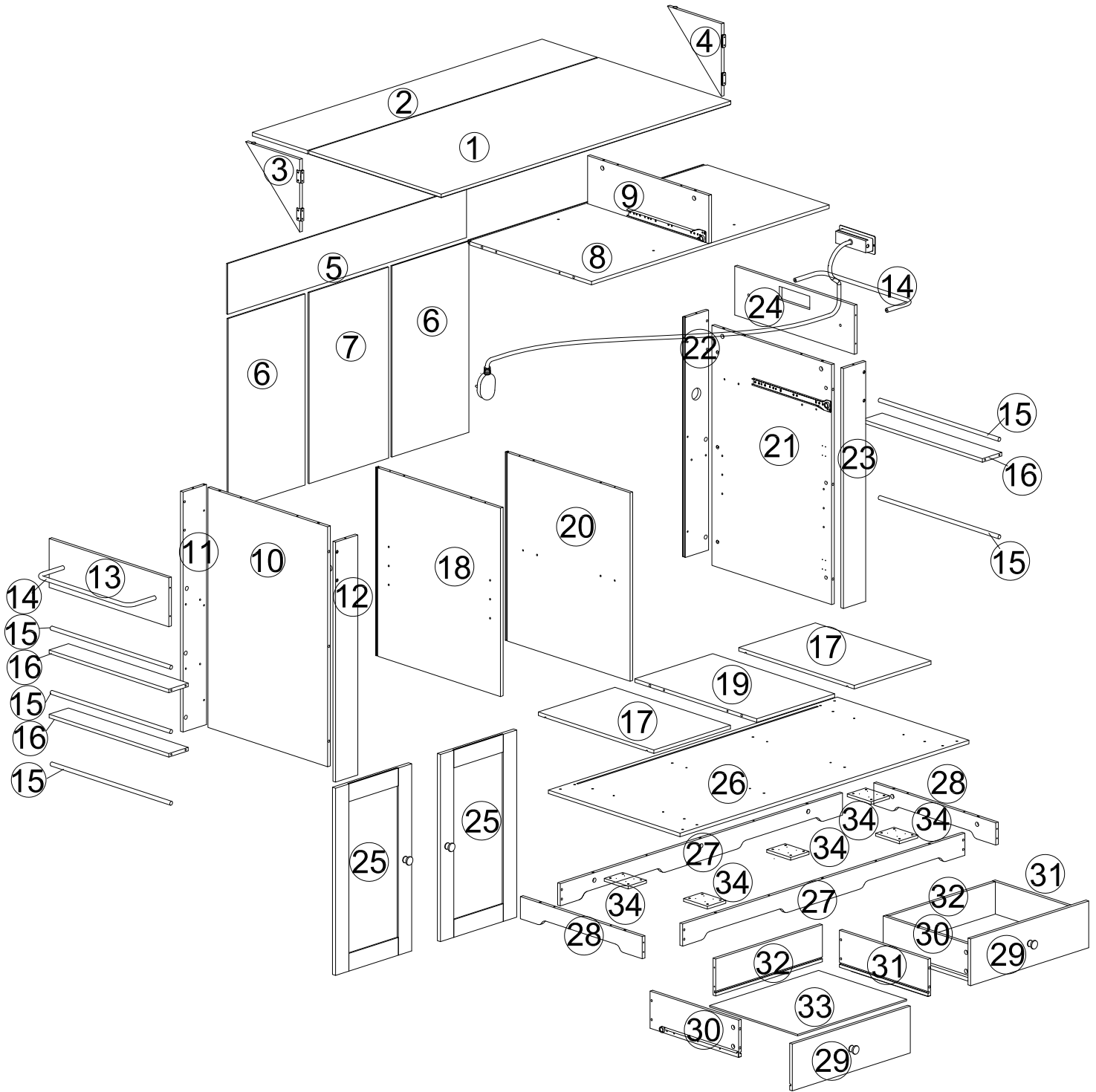

| | |
|--|---|
| Importer | COMHARBOR LIMITED |
| Add | Unit C, Swift point Cosford Lane, Rugby, CV21 1PY, GB |
| Email/URL | harborcomhar@gmail.com |
| Manufacturer | DongGuan RongTai Furniture Co.Ltd. |
| Add | Road 4-8, TieGangXiixin, Qishi, Dongguan, Guangdong |
| Email/URL | iriswan@rongtaifurniture.cn |
| Product identification | N639P285034 /N639P285035/N639P285036 |
| Made in | CHINA |
| COMHARBOR LIMITED Unit C, Swift Point Cosford Lane Rugby, CV21 1PY, GB harborcomhar@gmail .com | |

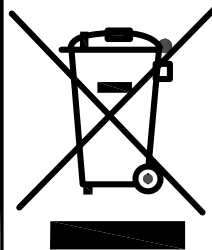

Product Name: Multiple Socket Outlets
 Model: BY213-BS021Y
 Rated input: 250V~ /50Hz/13A/Max 2990W /230V~
 USB output: 5.0V d.c. 2.1A.10.5W Max

Installationsanleitung/Installation Instruction/Instruction d'installation/
 Istruzioni di installazione/Instrucciones de instalación/Installatie-instructies/
 Installationsanvisningar/Instrukcje instalacji

Schritt 1/Step 1/ étape 1/ passo 1/paso 1 / stap 1/steg 1/ krok 1

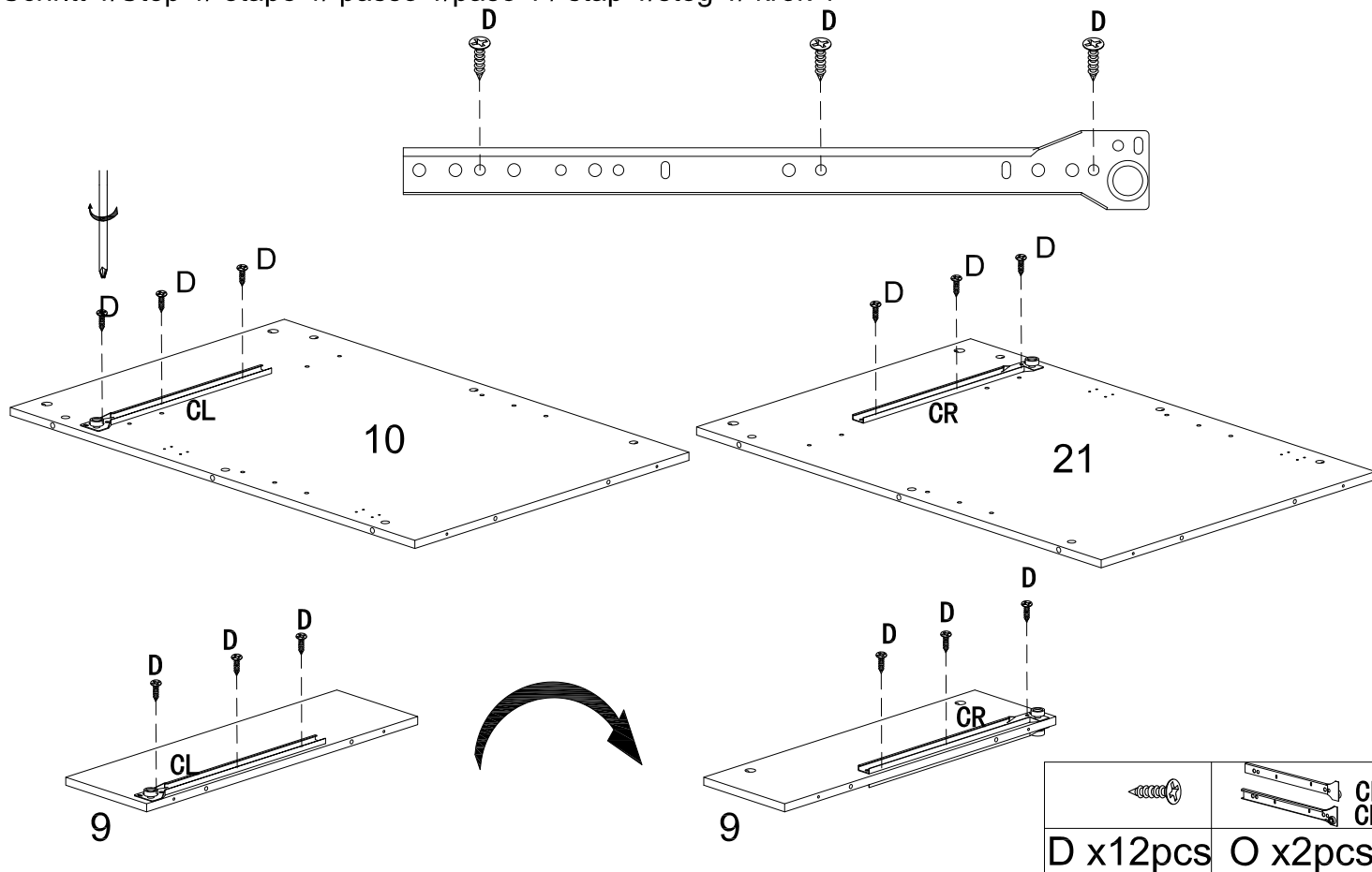

Schritt 2/Step 2/ étape 2/ passo 2/paso 2 / stap 2/steg 2/ krok 2

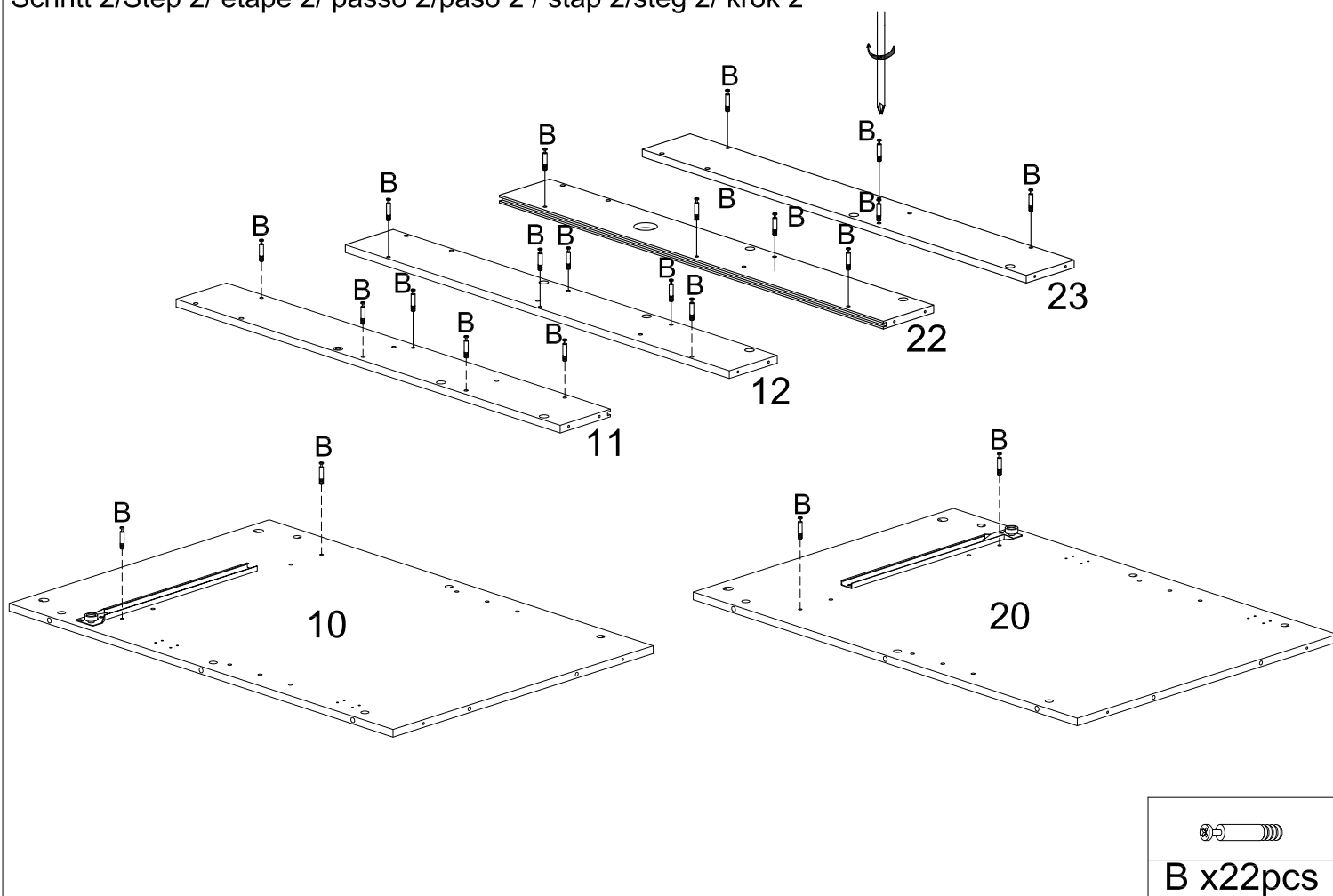

Installationsanleitung/Installation Instruction/Instruction d'installation/
 Istruzioni di installazione/Instrucciones de instalación/Installatie-instructies/
 Installationsanvisningar/Instrukcje instalacji

Schritt 3/Step 3/ étape 3/ passo 3/paso 3 / stap 3/steg 3/ krok 3

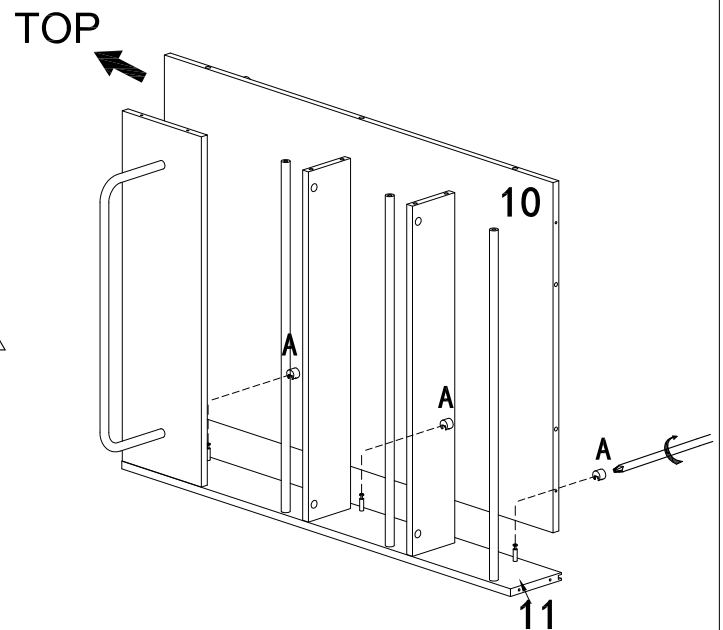
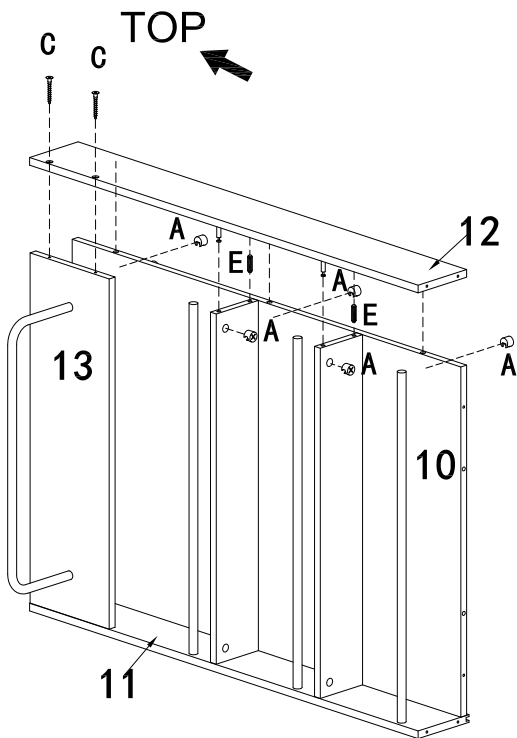
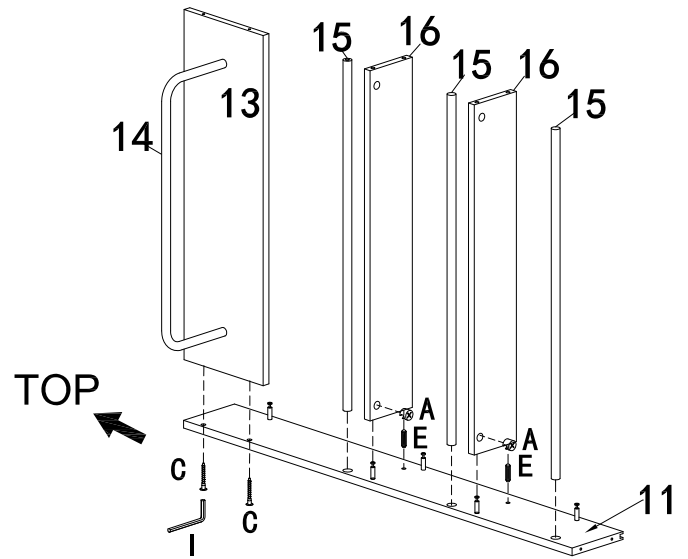
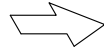
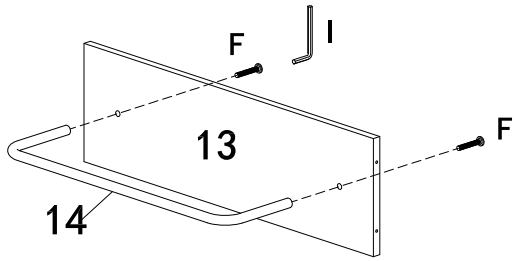



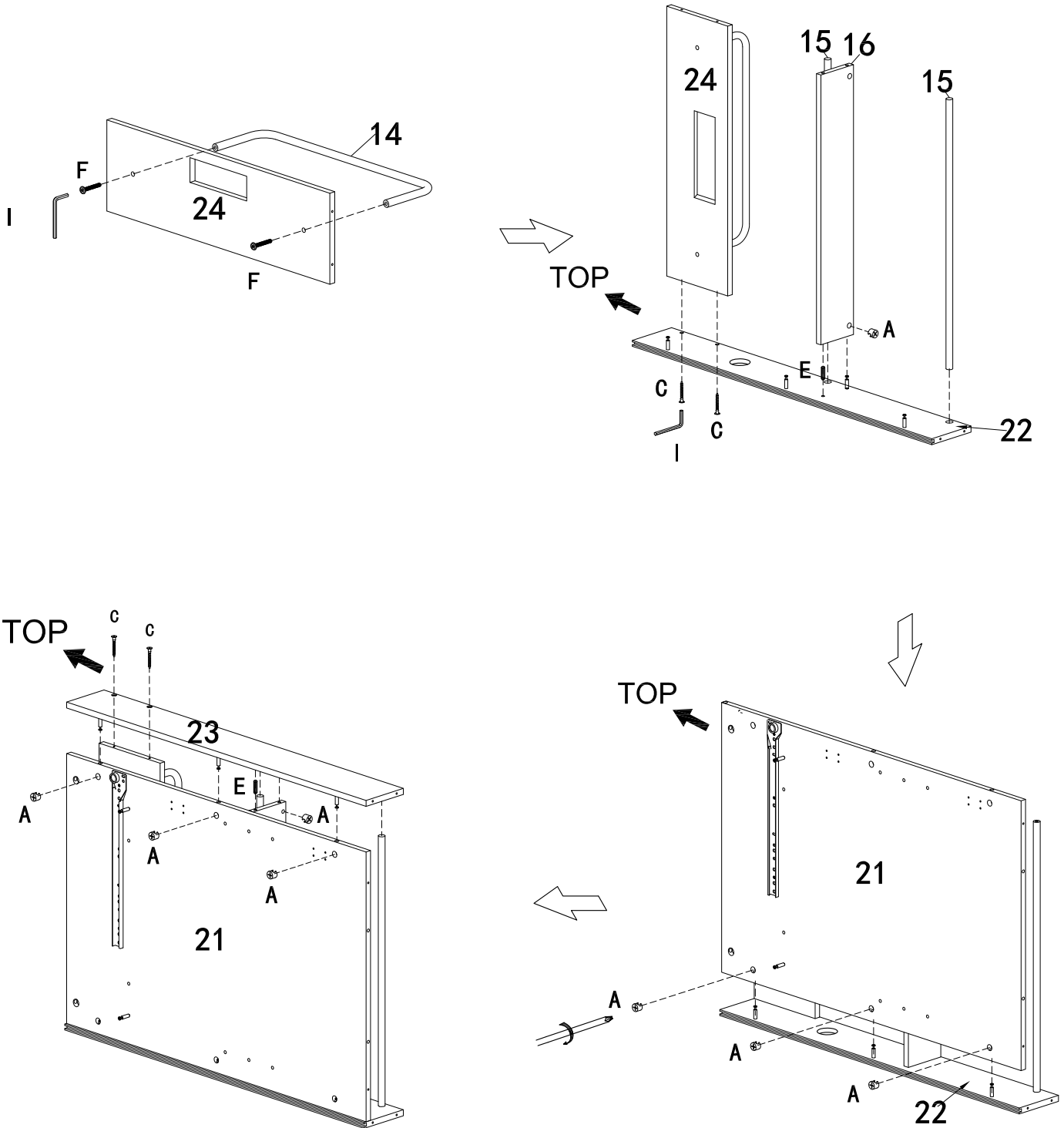

| | | | | |
|----------|---------|---------|---------|---|
| | | | | |
| A x10pcs | C x4pcs | E x4pcs | F x2pcs | I |

Installationsanleitung/Installation Instruction/Instruction d'installation/
 Istruzioni di installazione/Instrucciones de instalación/Installatie-instructies/
 Installationsanvisningar/Instrukcje instalacji

Schritt 4/Step 4/ étape4/ passo 4/paso 4 / stap 4/steg 4/ krok 4



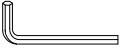

| | | | | |
|---|---|---|---|---|
|  |  |  |  |  |
| A x8pcs | C x4pcs | E x2pcs | F x2pcs | I |

Installationsanleitung/Installation Instruction/Instruction d'installation/
 Istruzioni di installazione/Instrucciones de instalación/Installatie-instructies/
 Installationsanvisningar/Instrukcje instalacji

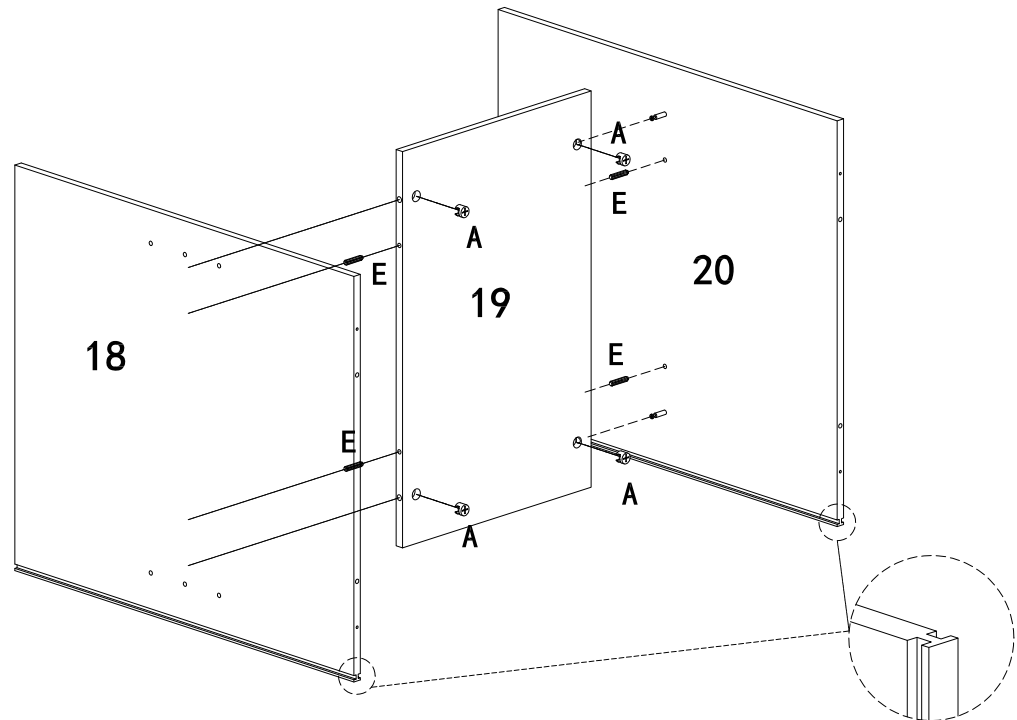
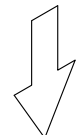
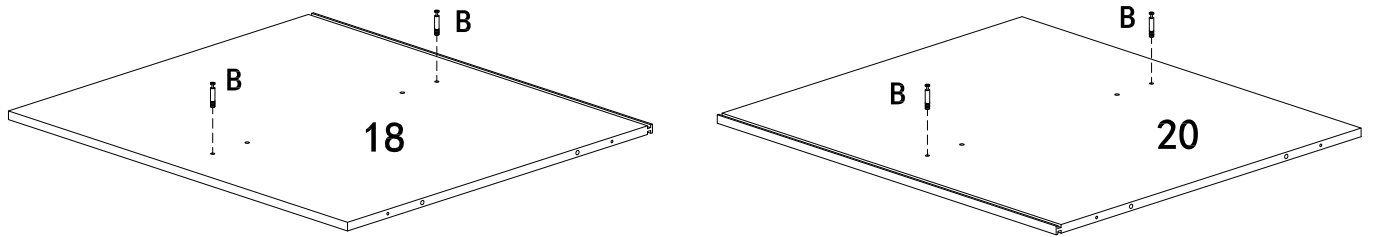
Schritt 5/Step 5/ étape 5/ passo 5/paso 5/ stap 5/steg 5/ krok 5

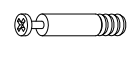



| | | |
|---|---|---|
|  |  |  |
| A x4pcs | B x4pcs | E x4pcs |

Installationsanleitung/Installation Instruction/Instruction d'installation/
 Istruzioni di installazione/Instrucciones de instalación/Installatie-instructies/
 Installationsanvisningar/Instrukcje instalacji

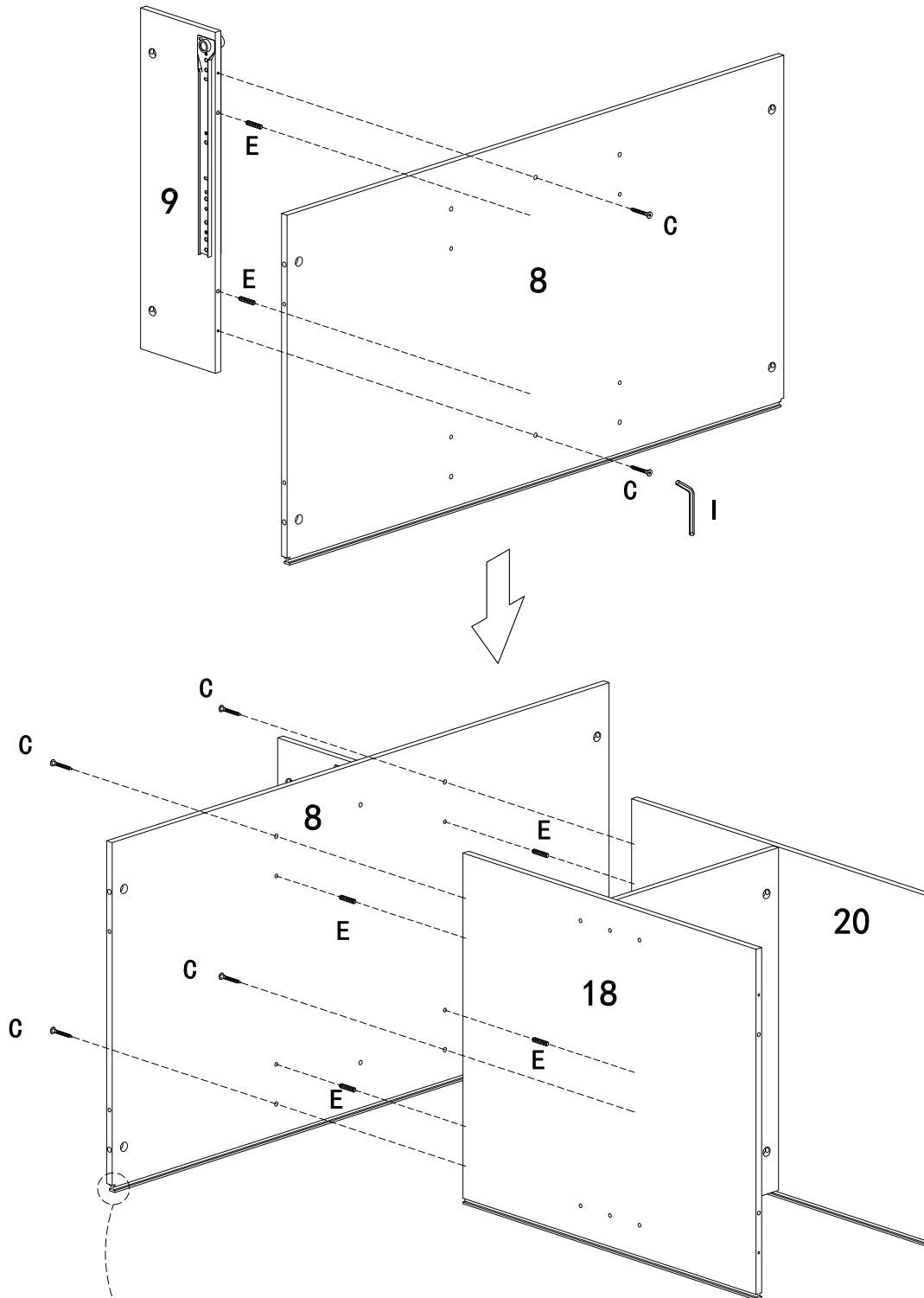
Schritt 6/Step 6/ étape 6/ passo 6/paso 6/ stap 6/steg 6/ krok 6





| | | |
|---|---|---|
|  |  |  |
| C x6pcs | E x6pcs | I |

Installationsanleitung/Installation Instruction/Instruction d'installation/
Istruzioni di installazione/Instrucciones de instalación/Installatie-instructies/
Installationsanvisningar/Instrukcje instalacji

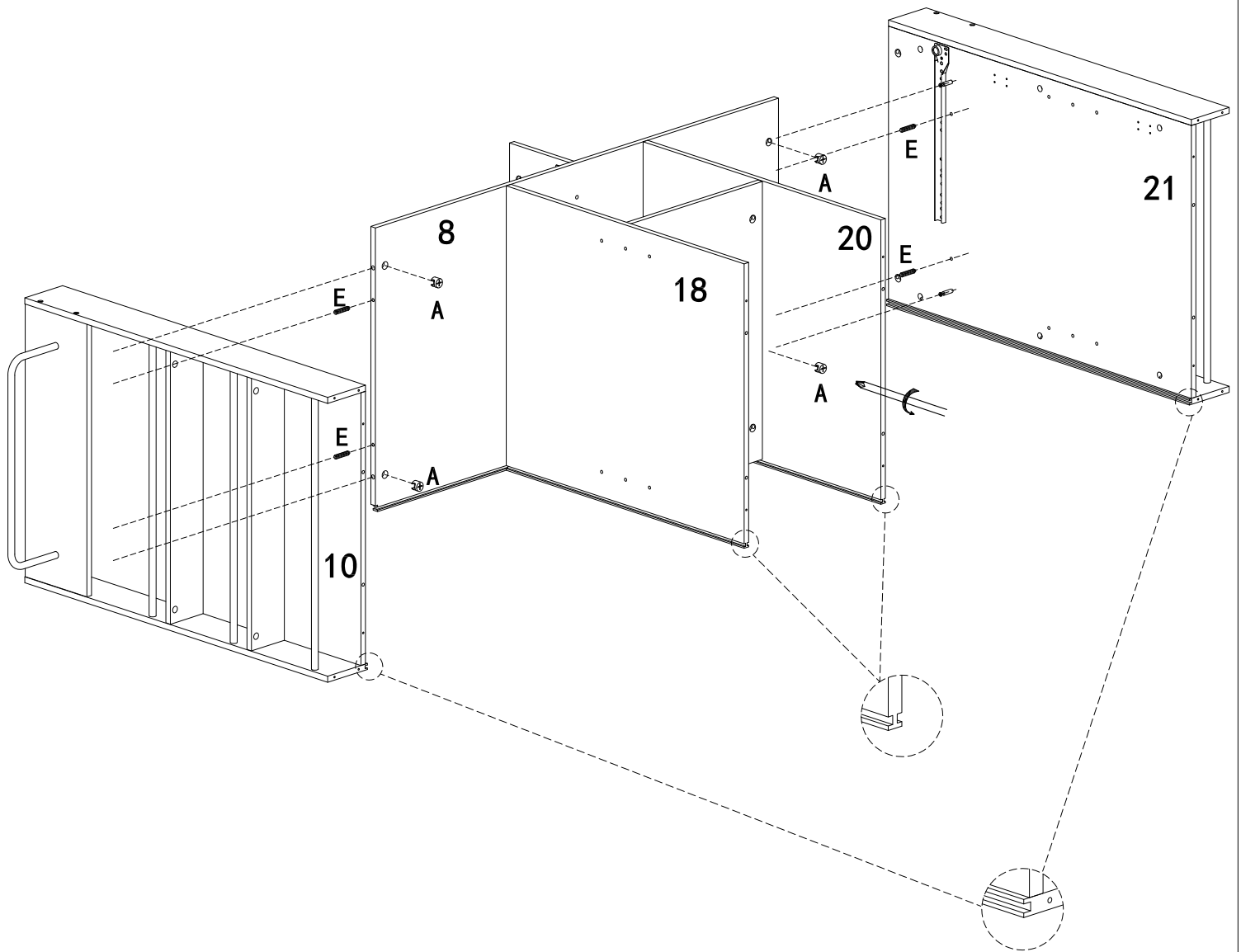
Schritt 7/Step 7/ étape 7/ passo 7/paso 7/ stap 7/steg 7/ krok 7



| | |
|---|---|
|  |  |
| A x4pcs | E x4pcs |

Installationsanleitung/Installation Instruction/Instruction d'installation/
Istruzioni di installazione/Instrucciones de instalación/Installatie-instructies/
Installationsanvisningar/Instrukcje instalacji



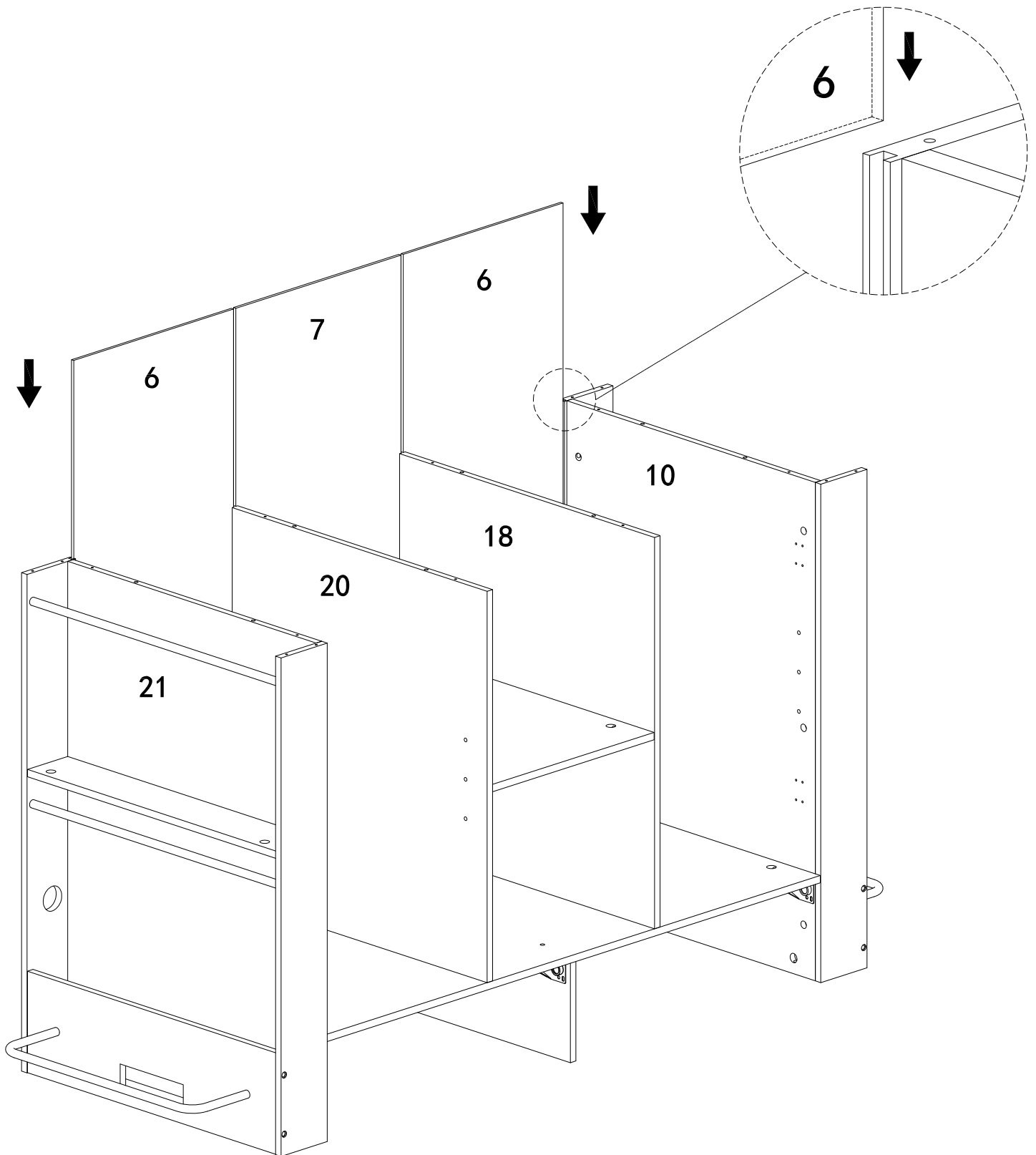

Schritt 8/Step 8/ étape 8/ passo 8/paso 8/ stap 8/steg 8/ krok 8

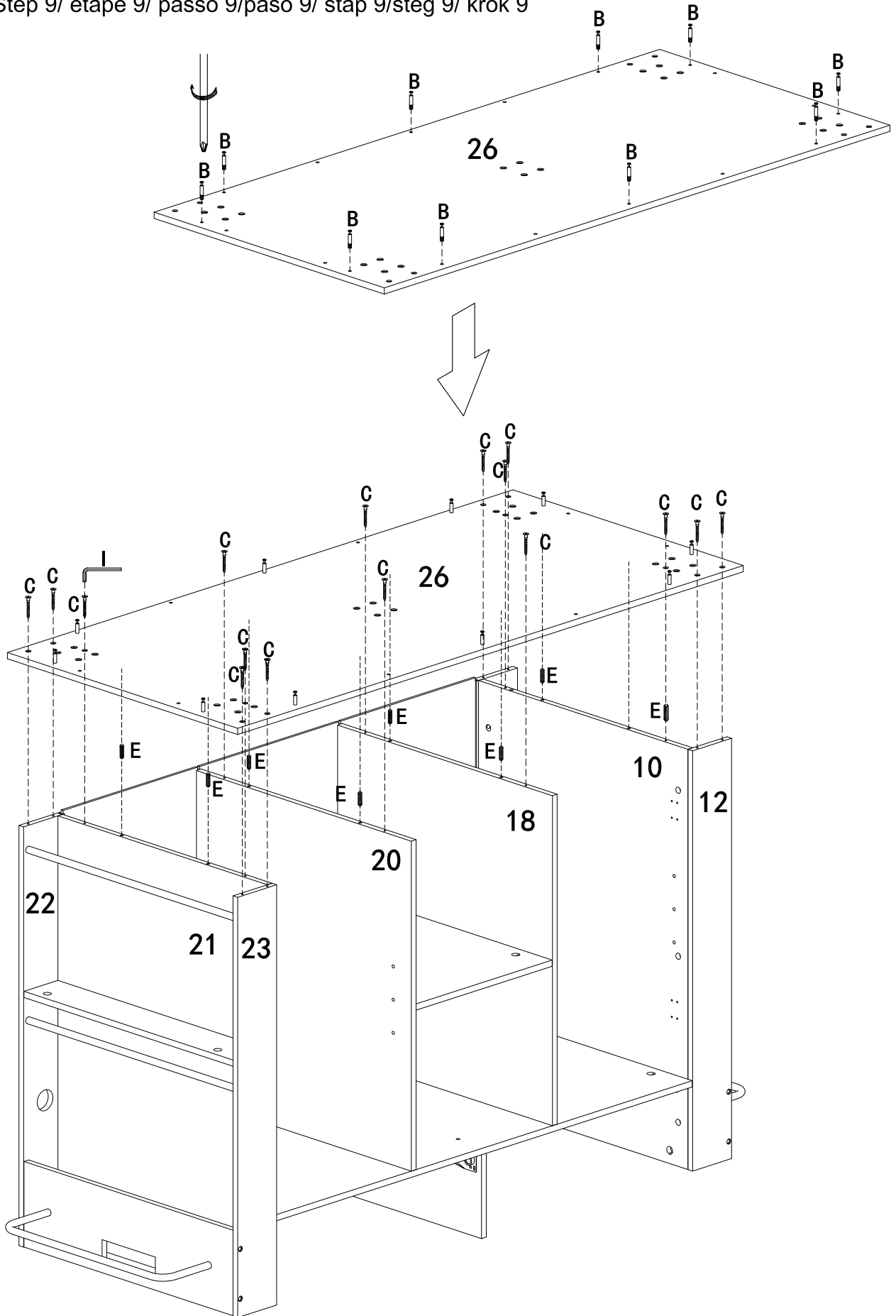

Installationsanleitung/Installation Instruction/Instruction d'installation/
 Istruzioni di installazione/Instrucciones de instalación/Installatie-instructies/
 Installationsanvisningar/Instrukcje instalacji

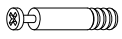
Schritt 9/Step 9/ étape 9/ passo 9/paso 9/ stap 9/steg 9/ krok 9





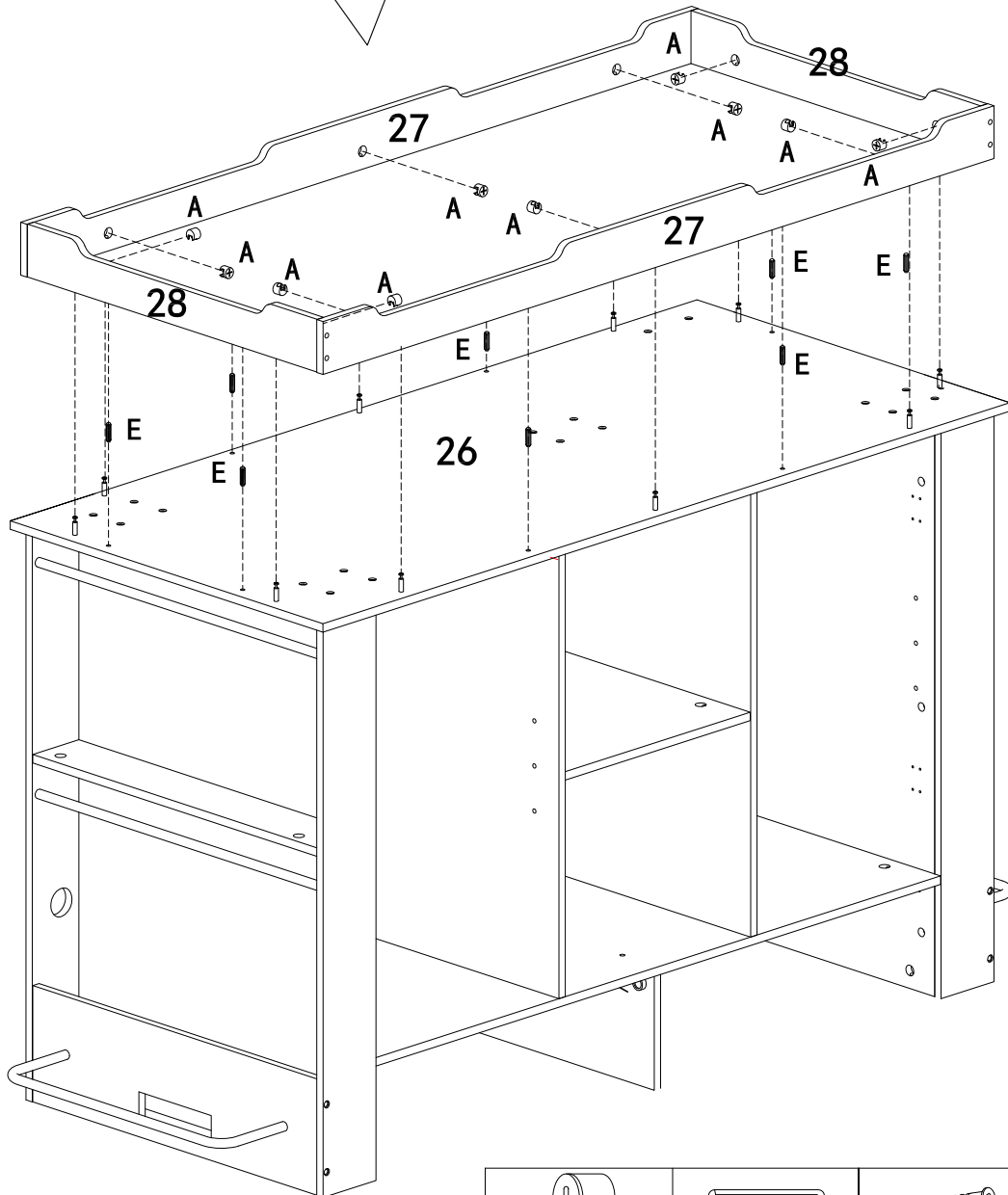
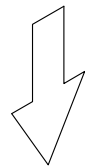
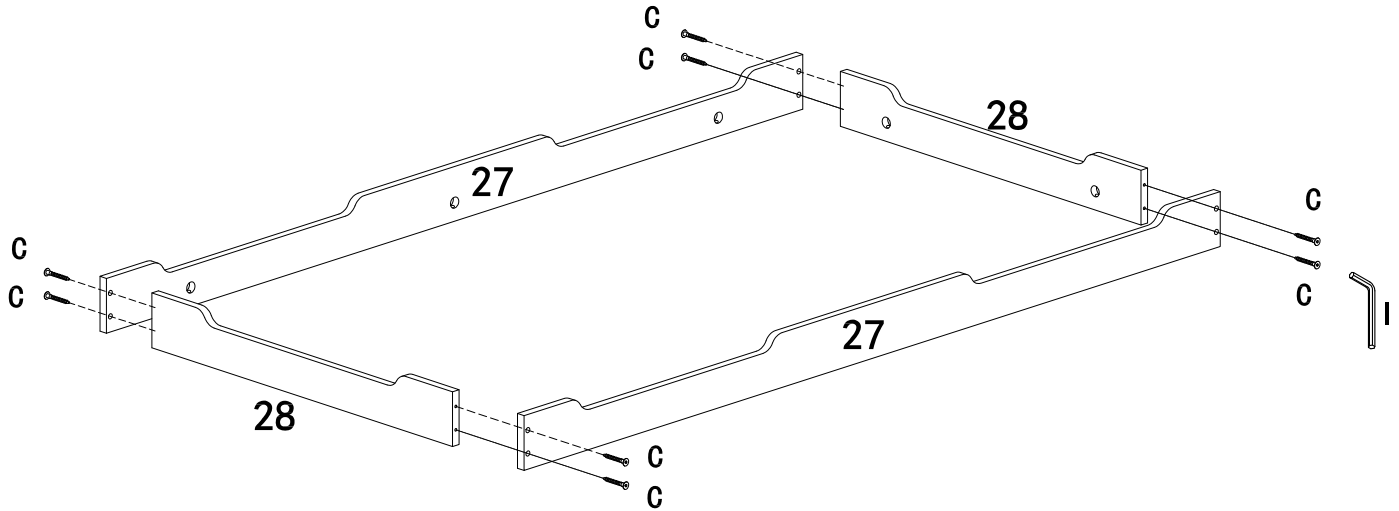

| | | | |
|---|---|---|---|
|  |  |  |  |
| B x10pcs | C x16pcs | E x8pcs | I |

Installationsanleitung/Installation Instruction/Instruction d'installation/
 Istruzioni di installazione/Instrucciones de instalación/Installatie-instructies/
 Installationsanvisningar/Instrukcje instalacji

Schritt 10/Step 10/ étape 10/ passo 10/paso 10/ stap 10/steg 10/ krok 10





| | | | |
|---|---|---|---|
|  |  |  |  |
| A x10pcs | E x8pcs | C x8pcs | I |

Installationsanleitung/Installation Instruction/Instruction d'installation/
Istruzioni di installazione/Instrucciones de instalación/Installatie-instructies/
Installationsanvisningar/Instrukcje instalacji

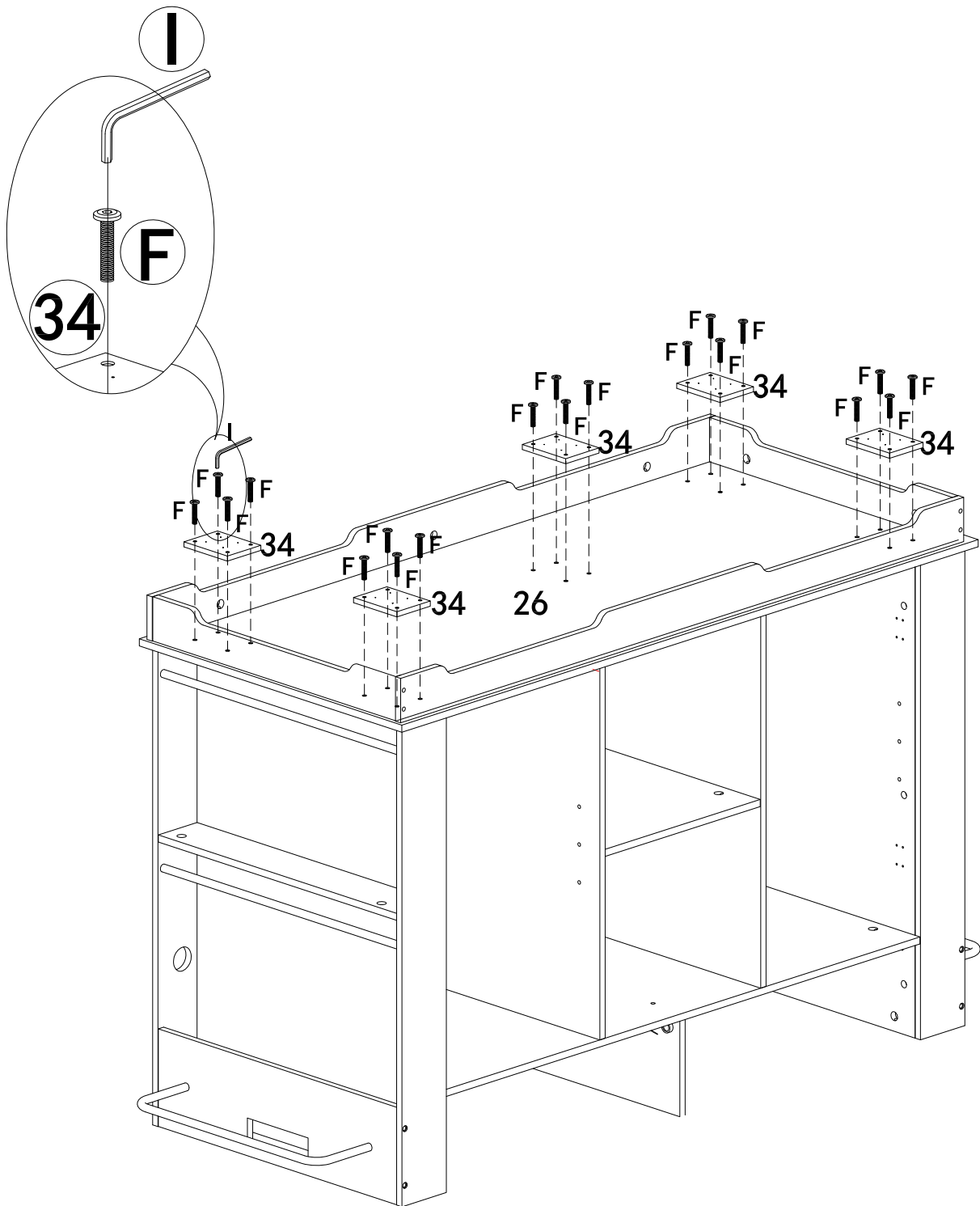
Schritt 11/Step 11/ étape 11/ passo 11/paso 11/ stap 11/steg 11/ krok 11





| | |
|---|---|
|  |  |
| F x20pcs | I |

Installationsanleitung/Installation Instruction/Instruction d'installation/
Istruzioni di installazione/Instrucciones de instalación/Installatie-instructies/
Installationsanvisningar/Instrukcje instalacji

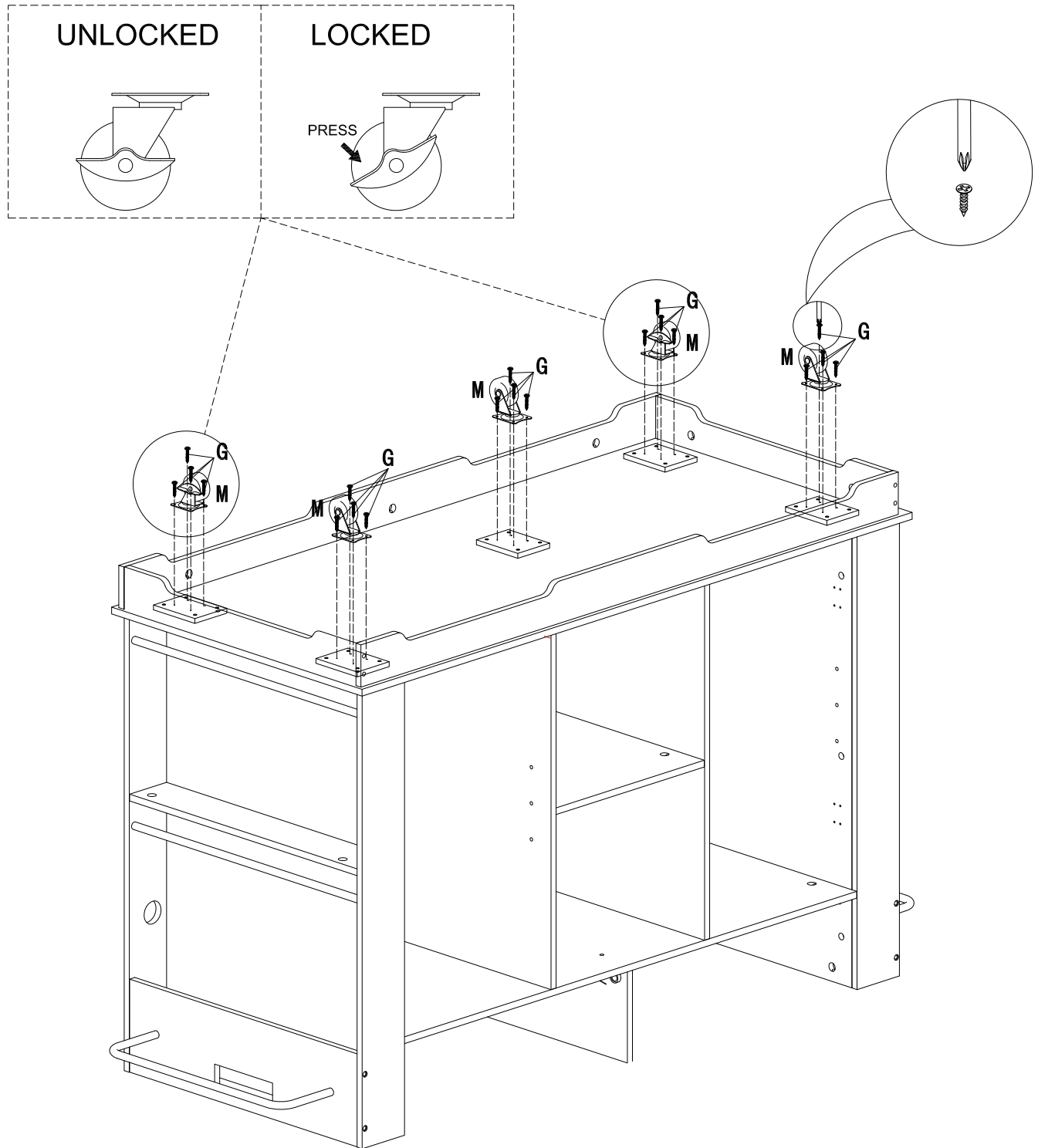
Schritt 12/Step 12/ étape 12/ passo 12/paso 12/ stap 12/steg 12/ krok 12





| | |
|---|---|
|  |  |
| G x20pcs | M x5pcs |

Installationsanleitung/Installation Instruction/Instruction d'installation/
Istruzioni di installazione/Instrucciones de instalación/Installatie-instructies/
Installationsanvisningar/Instrukcje instalacji

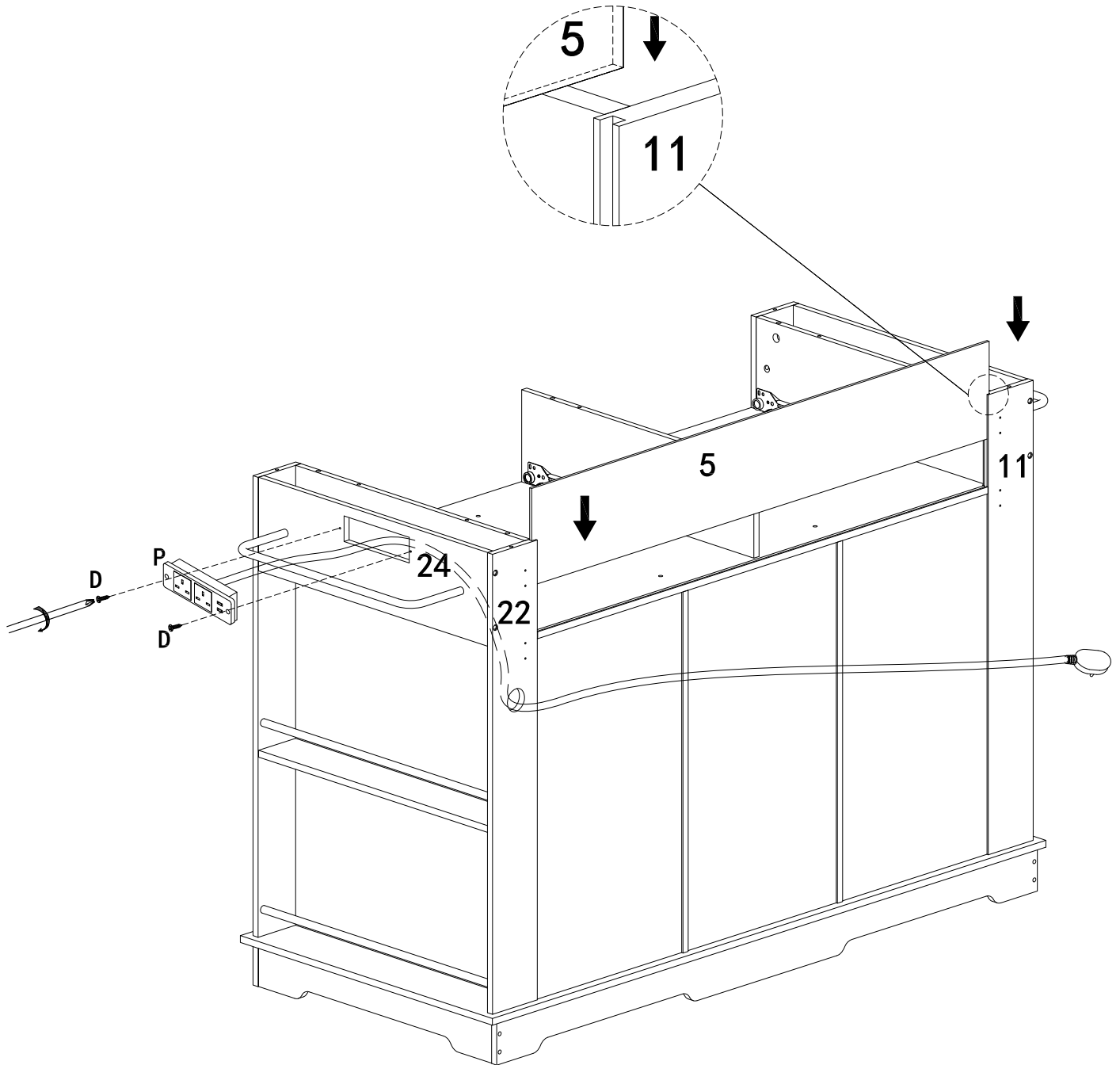
Schritt 13/Step 13/ étape 13/ passo 13/paso 13/ stap 13/steg 13/ krok 13





| | |
|---|---|
|  |  |
| D x2pcs | P x1pc |

Installationsanleitung/Installation Instruction/Instruction d'installation/
 Istruzioni di installazione/Instrucciones de instalación/Installatie-instructies/
 Installationsanvisningar/Instrukcje instalacji

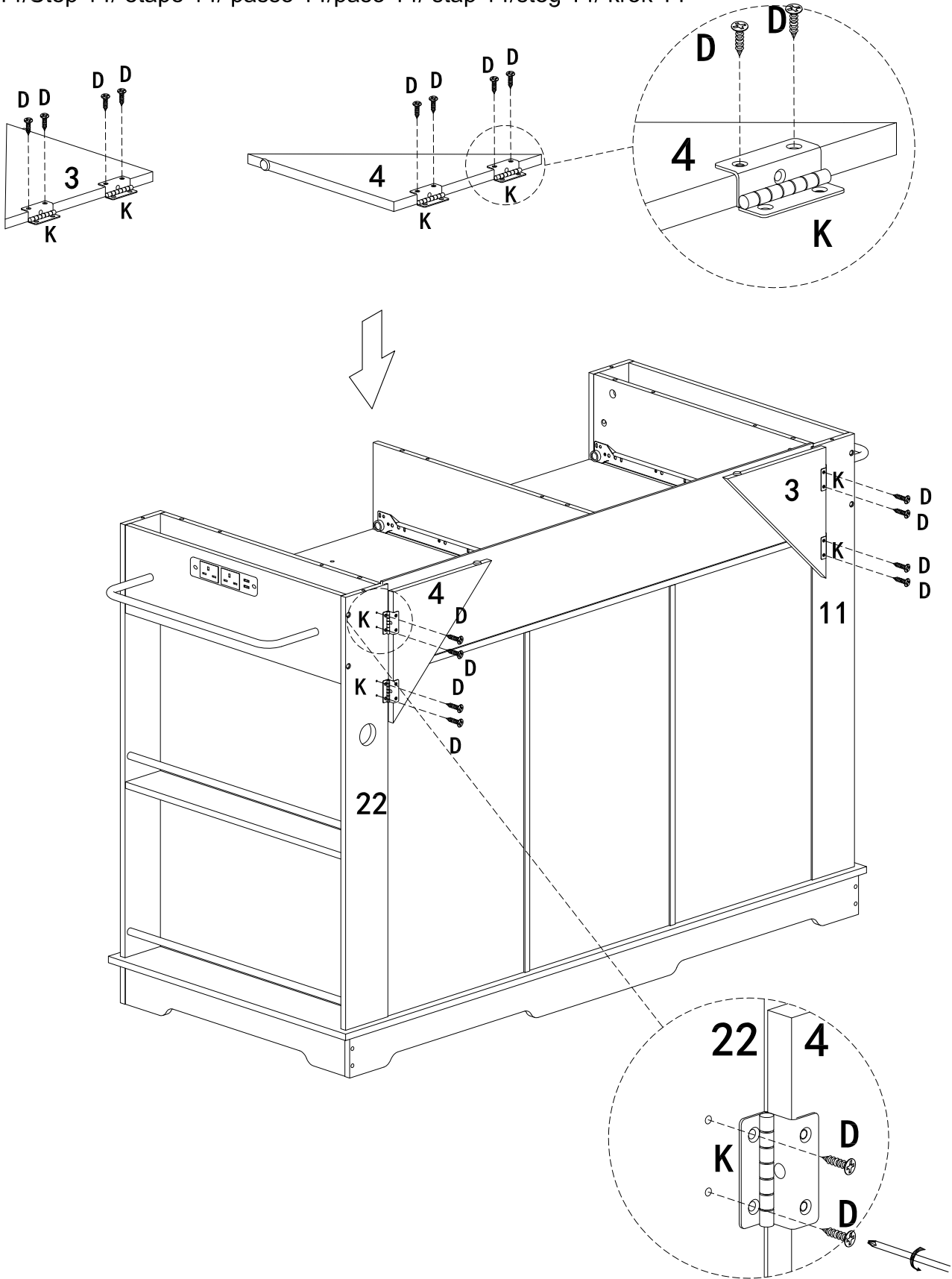
Schritt 14/Step 14/ étape 14/ passo 14/paso 14/ stap 14/steg 14/ krok 14





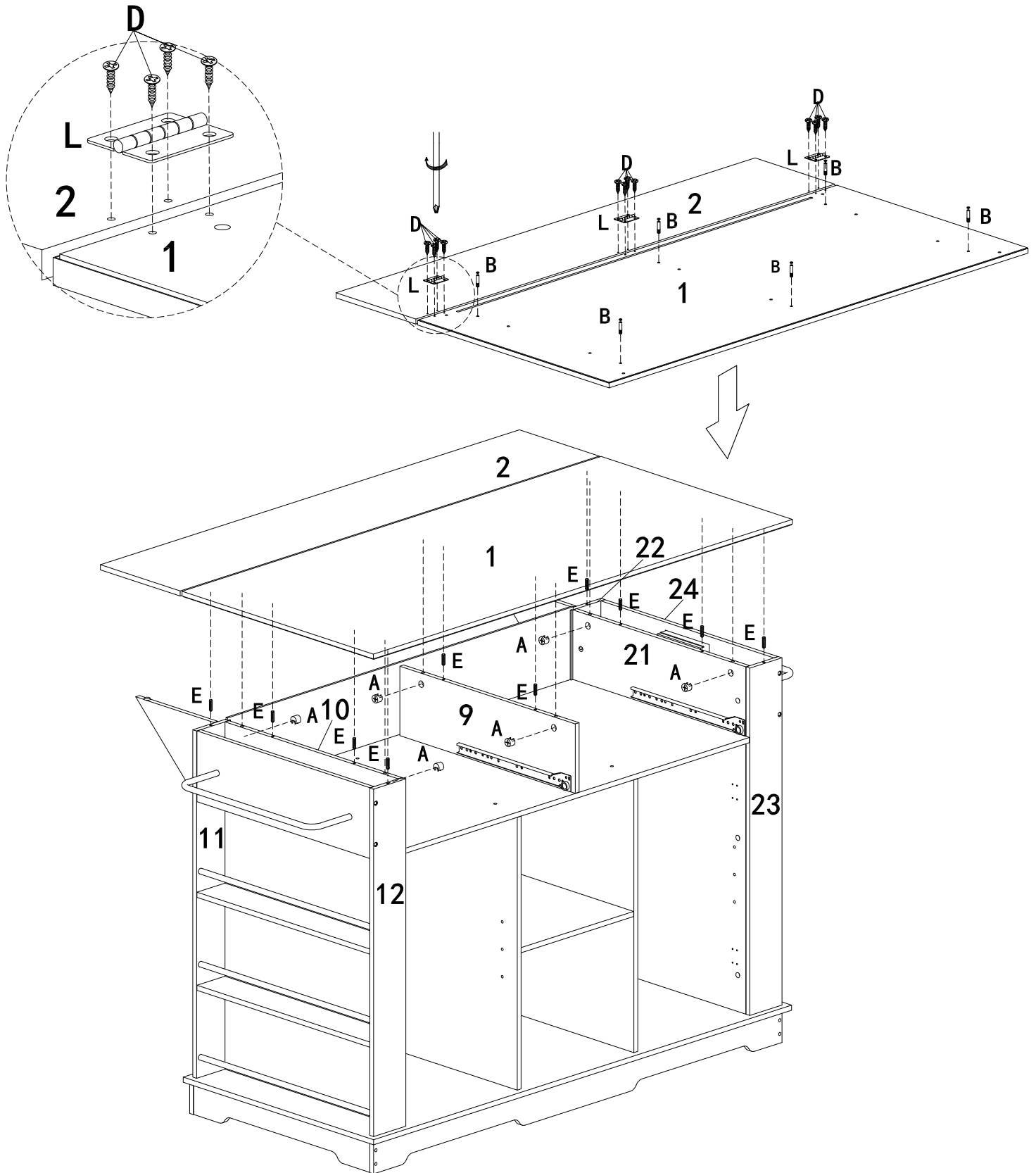

| | |
|---|---|
|  |  |
| D x16pcs | K x4pcs |

Installationsanleitung/Installation Instruction/Instruction d'installation/
 Istruzioni di installazione/Instrucciones de instalación/Installatie-instructies/
 Installationsanvisningar/Instrukcje instalacji

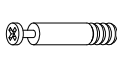
Schritt 15/Step 15/ étape 15/ passo 15/paso 15/ stap 15/steg 15/ krok 15



| | | | | |
|---|---|---|---|---|
|  |  |  |  |  |
| A x6pcs | B x6pcs | D x12pcs | E x10pcs | L x3pcs |

Installationsanleitung/Installation Instruction/Instruction d'installation/
 Istruzioni di installazione/Instrucciones de instalación/Installatie-instructies/
 Installationsanvisningar/Instrukcje instalacji

Schritt 16/Step 16/ étape 16/ passo 16/paso 16/ stap 16/steg 16/ krok 16

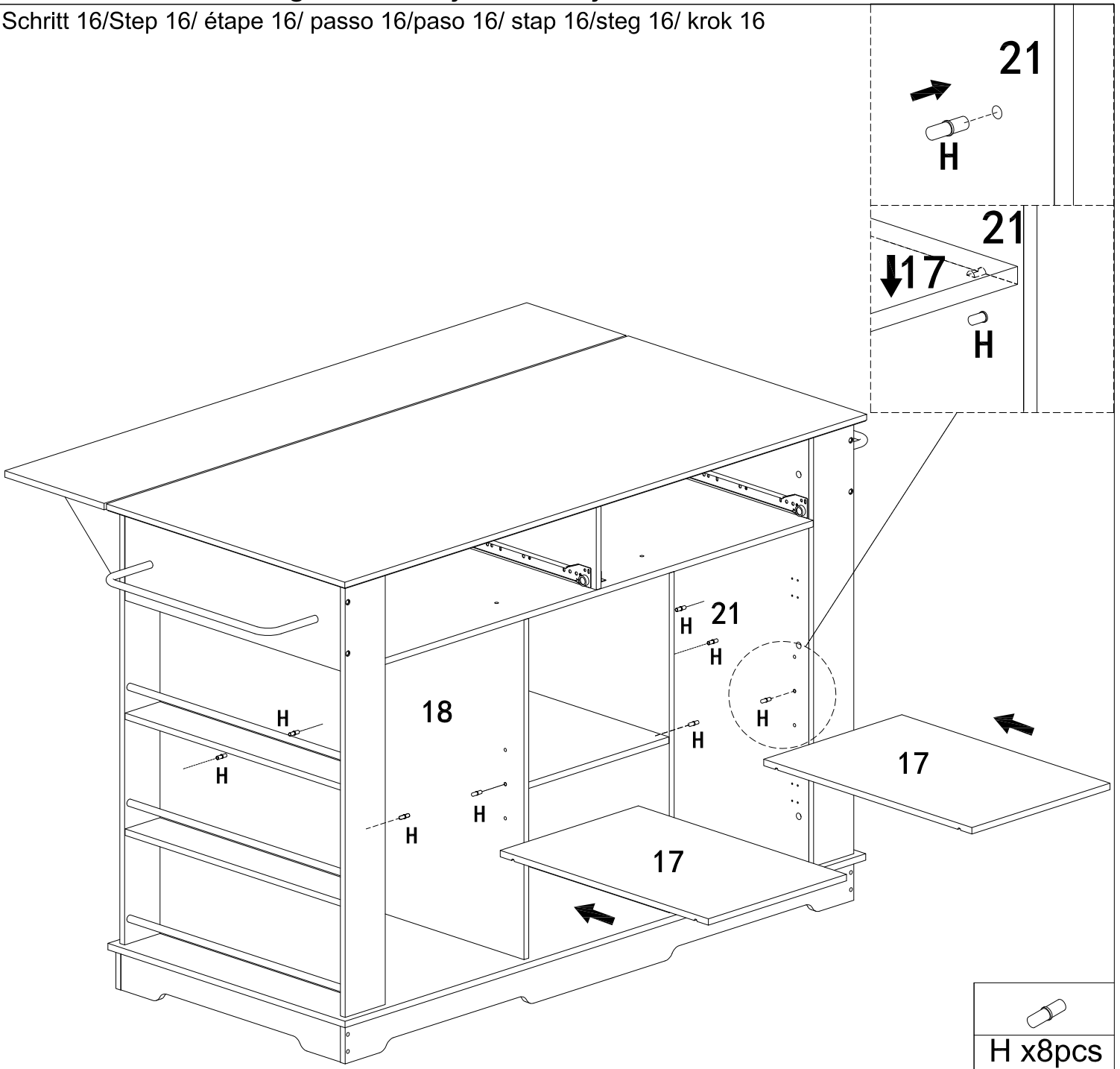



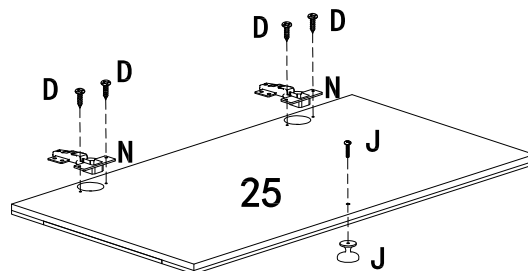

 H x8pcs

Schritt 17/Step 17/ étape 17/ passo 17/paso 17/ stap 17/steg 17/ krok 17

X 2PCS



| | | |
|--|---|---|
|  |  |  |
| D x8pcs | J x2pcs | N x4pcs |

Installationsanleitung/Installation Instruction/Instruction d'installation/
Istruzioni di installazione/Instrucciones de instalación/Installatie-instructies/
Installationsanvisningar/Instrukcje instalacji

Schritt 18/Step 18/ étape 18/ passo 18/paso 18/ stap 18/steg 18/ krok 18

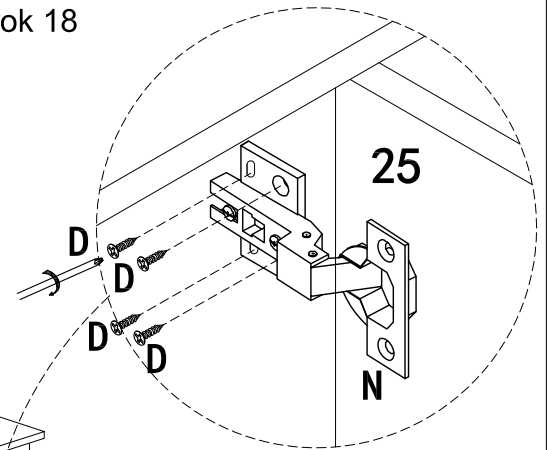
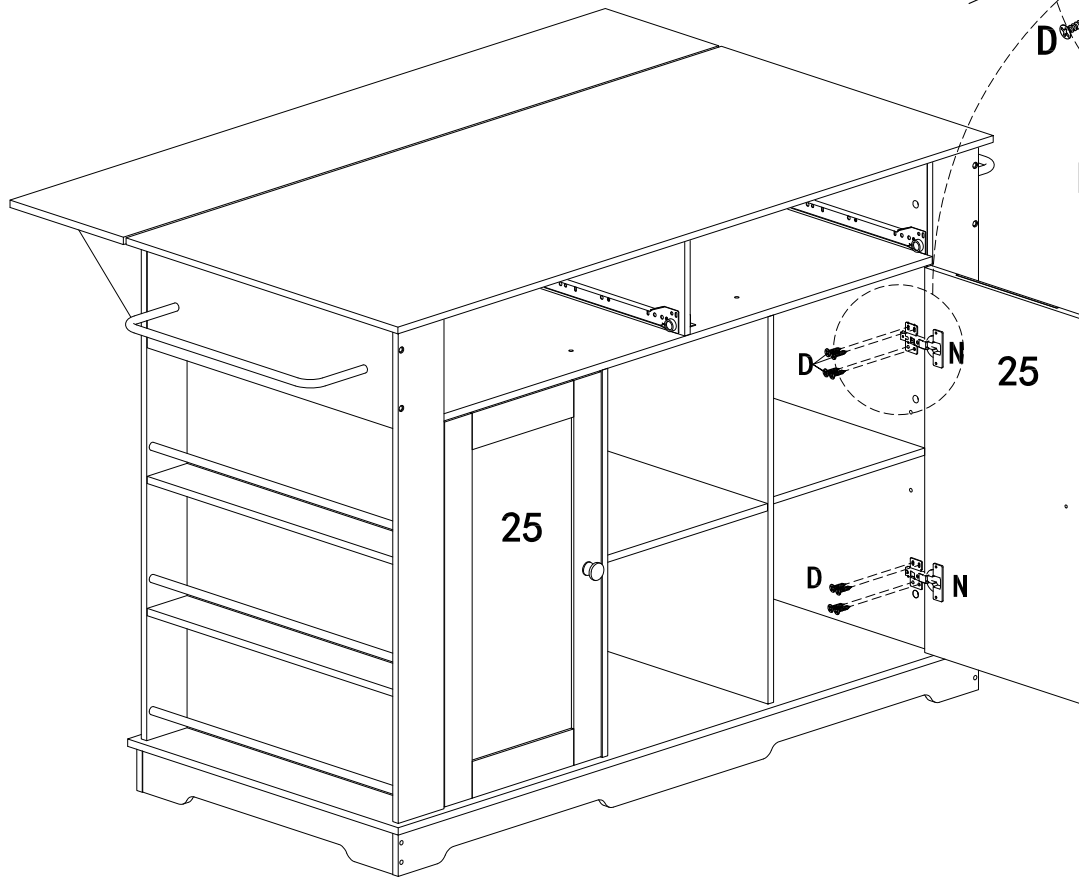



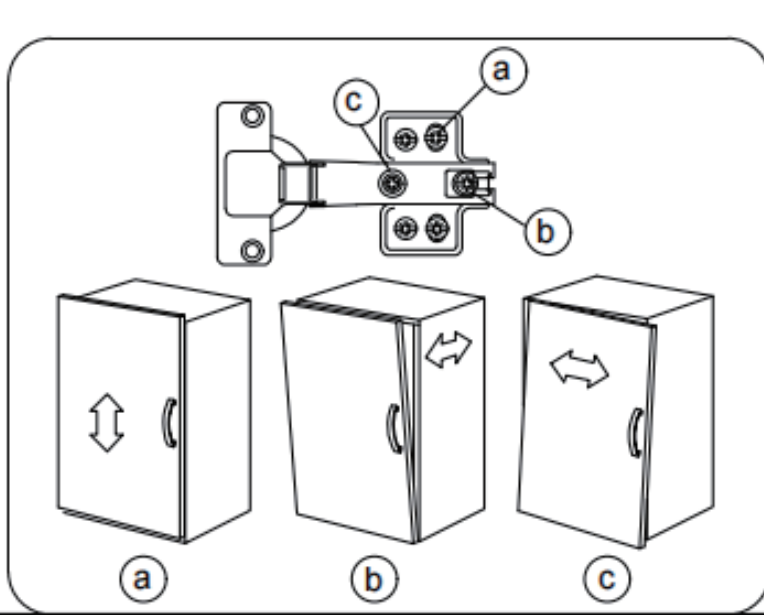

Repeat this assembly step for another door

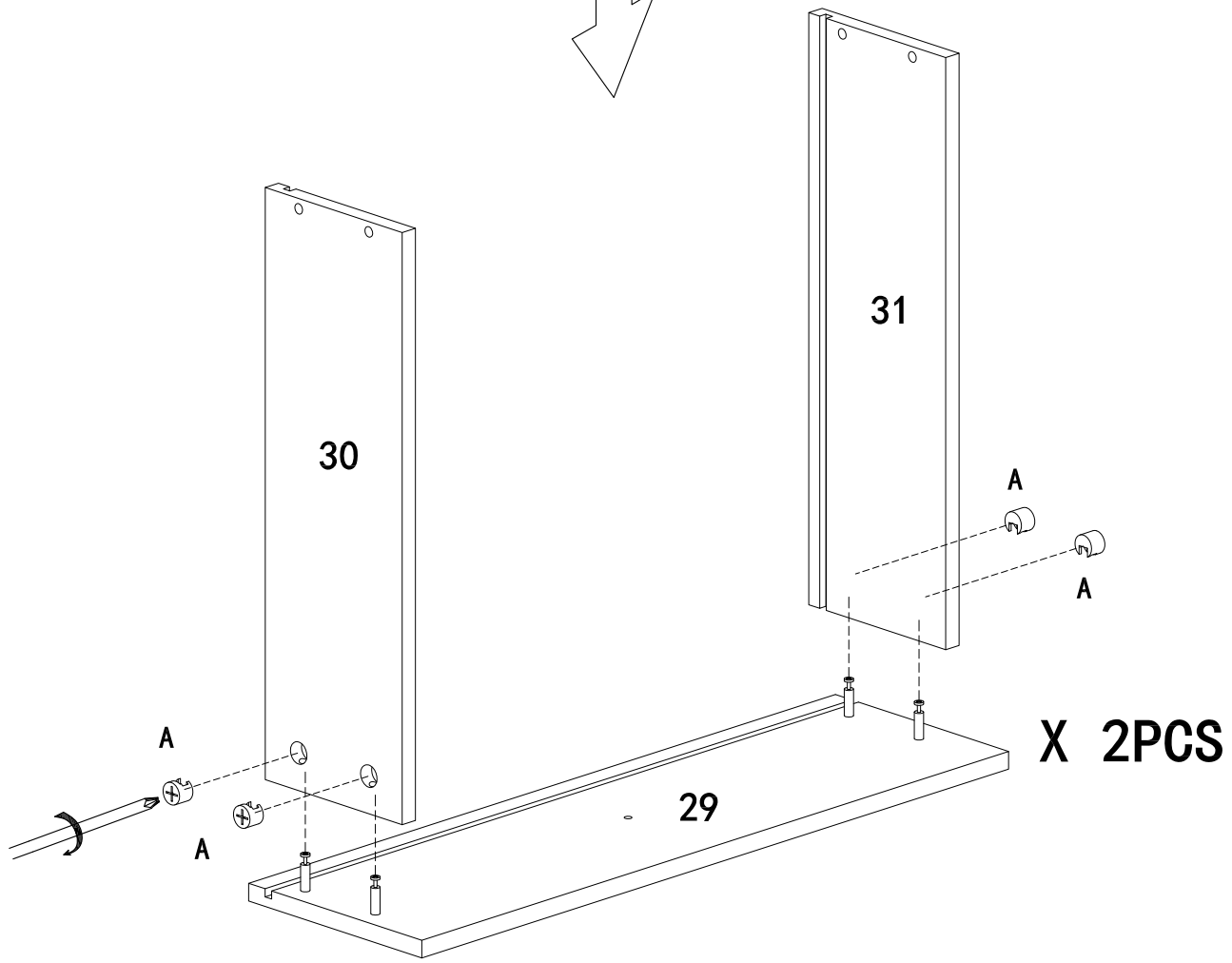
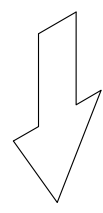
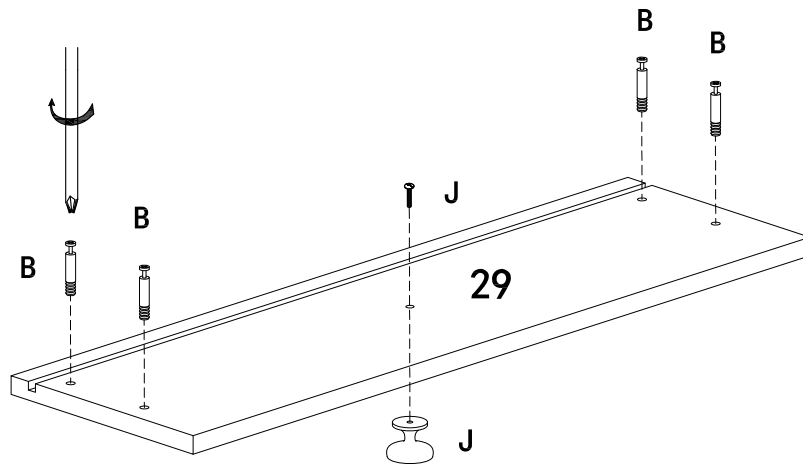

Installationsanleitung/Installation Instruction/Instruction d'installation/
 Istruzioni di installazione/Instrucciones de instalación/Installatie-instructies/
 Installationsanvisningar/Instrukcje instalacji

Schritt 19/Step 19/ étape 19/ passo 19/paso 19/ stap 19/steg 19/ krok 19

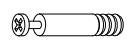



| | | |
|---|---|---|
|  |  |  |
| A x8pcs | B x8pcs | J x2pcs |

Installationsanleitung/Installation Instruction/Instruction d'installation/
Istruzioni di installazione/Instrucciones de instalación/Installatie-instructies/
Installationsanvisningar/Instrukcje instalacji

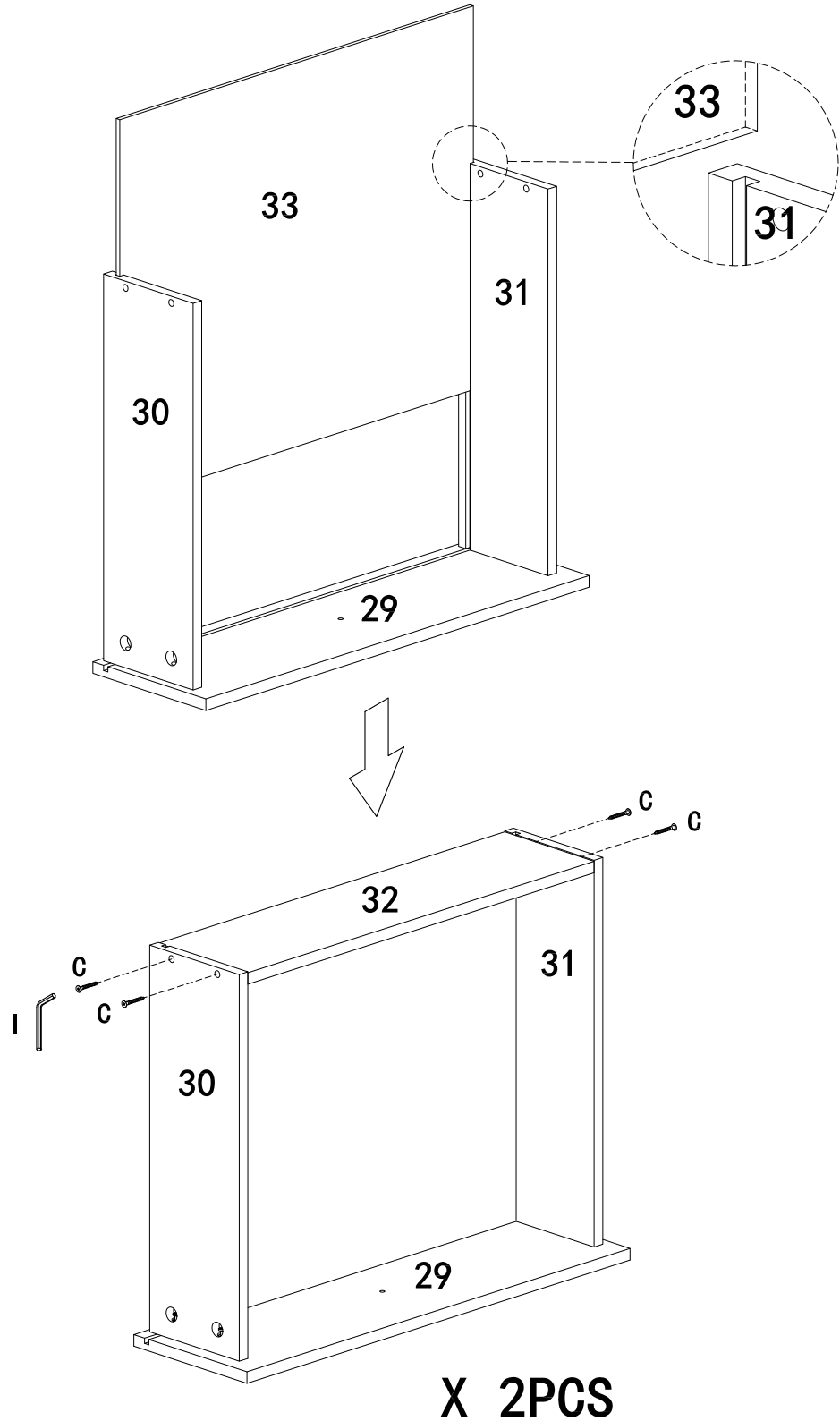
Schritt 20/Step 20/ étape 20/ passo 20/paso 20/ stap 20/steg 20/ krok 20



| | |
|---|---|
|  |  |
| C x8pcs | I |



Installationsanleitung/Installation Instruction/Instruction d'installation/
 Istruzioni di installazione/Instrucciones de instalación/Installatie-instructies/
 Installationsanvisningar/Instrukcje instalacji

Schritt 21/Step 21/ étape 21/ passo 21/paso 21/ stap 21/steg 21/ krok 21

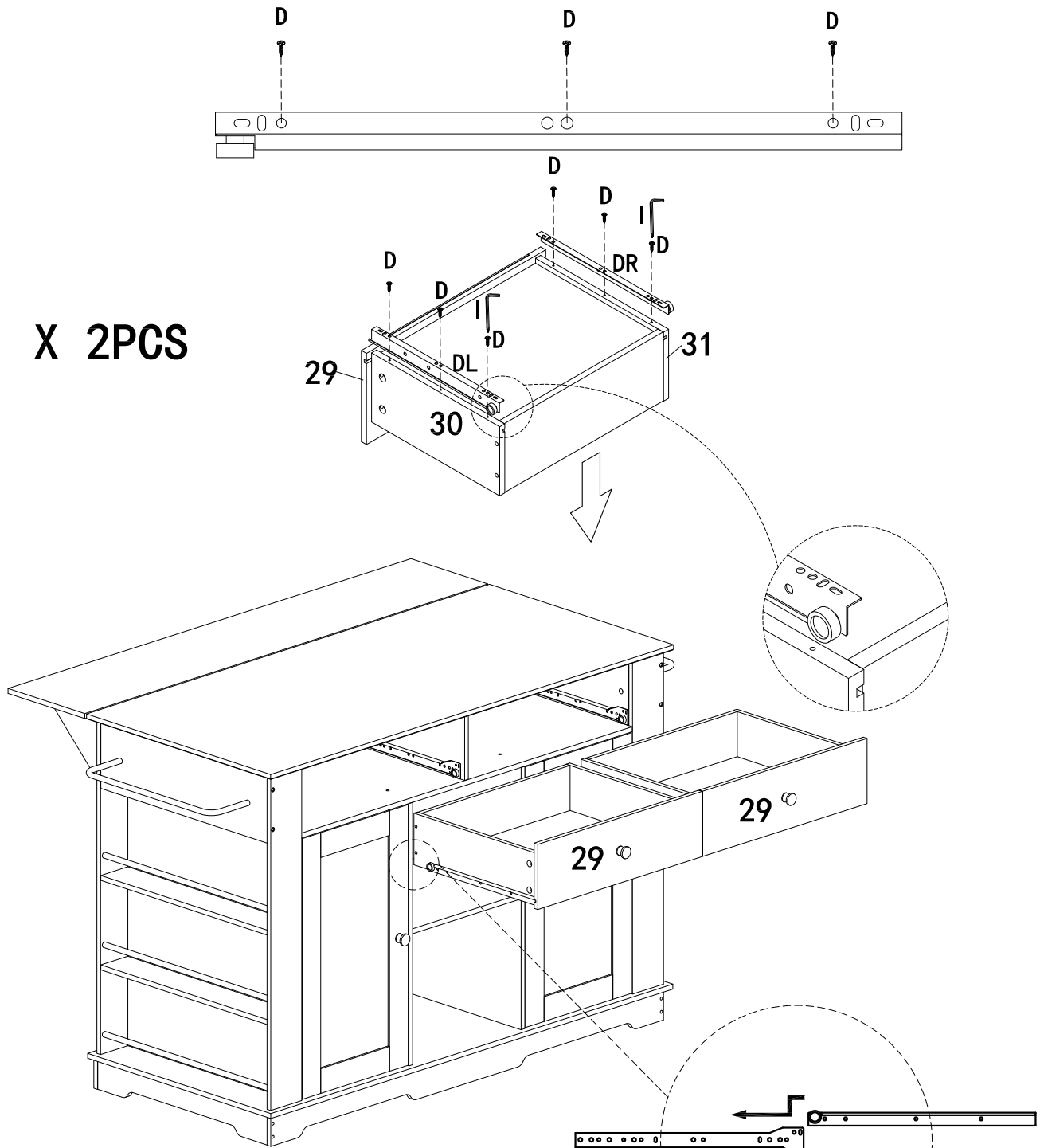
X 2PCS



Installation abgeschlossen
 Installation Completed
 Installation terminée
 Installazione completata
 Instalación finalizada
 Installatie voltooid
 Installation slutförd
 Instalacja zakończona

| | |
|---|--|
|  |  DLx2 DRx2 |
| D x12pcs | O x2pcs |



China

Attestation of Conformity

No. N8AUK 120613 0003 Rev. 00

Holder of Attestation: **DONGGUAN BAIYOU ELECTRONIC CO.,LTD**

2F A Building Wufeng Industrial, Jintan Road, Shijie Town
523290 Dongguan City
PEOPLE'S REPUBLIC OF CHINA

Product: **Multiple Socket Outlets**

This Attestation of Conformity is issued on a voluntary basis according to the Electrical Equipment (Safety) Regulations 2016 relating to electrical equipment designed for use within certain voltage limits. It confirms that the listed equipment complies with the principal protection requirements of the regulation and is based on the technical specifications applicable at the time of issuance. It refers only to the particular sample submitted for conformity assessment.

For details see: www.tuvsud.com/ps-cert

Test report no.: 874102337710-00

Date, 2023-09-08

(Jie Zhu)

Page 1 of 3

This Attestation does not replace the regulatory UK Declaration of Conformity (DoC) and does not allow for UKCA marking. After preparation of the necessary technical documentation and establishing compliance to requirements of all applicable regulations, the manufacturer may sign a DoC and apply the UKCA marking. The DoC is issued under the sole responsibility of the manufacturer.

**UK
CA**

TUV®



China

Attestation of Conformity

No. N8AUK 120613 0003 Rev. 00

Model(s): **BY213-BS011, BY213-BS011-C, BY213-BS021, BY213-BS021-C, BY213-BS031, BY213-BS031-C, BY213-BS041, BY213-BS041-C**

Parameters:

Rated voltage: 250V~
 Rated frequency: 50Hz
 Rated current: 13A
 Protection class: I
 Degree of protection: IP20
 Type of cable: H05VV-F 3G1.0mm² or H05VV-F 3G1.25mm² or H05VV-F 3G1.5mm²

Remark: For BY213-BS011, BY213-BS021, BY213-BS031, BY213-BS041:
 USB rated output voltage:5.0VDC
 USB rated output current:
 Single Type A: 2.1A max
 Type A + Type A: 2.1A max

For BY213-BS011-C, BY213-BS021-C, BY213-BS031-C, BY213-BS041-C:
 USB rated output voltage:5.0VDC
 USB rated output current:
 Single Type A: 3.0A max
 Single Type C: 3.0A max
 Type A + Type C: 3.1A max
 USB rated output voltage:9.0VDC
 USB rated output current:
 Single Type A: 2.0A max
 Single Type C: 2.22A max
 USB rated output voltage:12.0VDC
 USB rated output current:
 Single Type A:1.5A max
 Single Type C: 1.67A max

Page 2 of 3

This Attestation does not replace the regulatory UK Declaration of Conformity (DoC) and does not allow for UKCA marking. After preparation of the necessary technical documentation and establishing compliance to requirements of all applicable regulations, the manufacturer may sign a DoC and apply the UKCA marking. The DoC is issued under the sole responsibility of the manufacturer.





China

Attestation of Conformity

No. N8AUK 120613 0003 Rev. 00

| Model | Number of socket-outlets | With two USB ports, type A +type A | With two USB ports, type A +type C |
|---------------|--------------------------|------------------------------------|------------------------------------|
| BY213-G011Y | 1 | Yes | No |
| BY213-G011Y-C | 1 | No | Yes |
| BY213-G021Y | 2 | Yes | No |
| BY213-G021Y-C | 2 | No | Yes |
| BY213-G031Y | 3 | Yes | No |
| BY213-G031Y-C | 3 | No | Yes |
| BY213-G041Y | 4 | Yes | No |
| BY213-G041Y-C | 4 | No | Yes |

Tested according to:

BS 1363-2:2016/A1:2018

Page 3 of 3

This Attestation does not replace the regulatory UK Declaration of Conformity (DoC) and does not allow for UKCA marking. After preparation of the necessary technical documentation and establishing compliance to requirements of all applicable regulations, the manufacturer may sign a DoC and apply the UKCA marking. The DoC is issued under the sole responsibility of the manufacturer.

