

Version:1.0

DJ504525

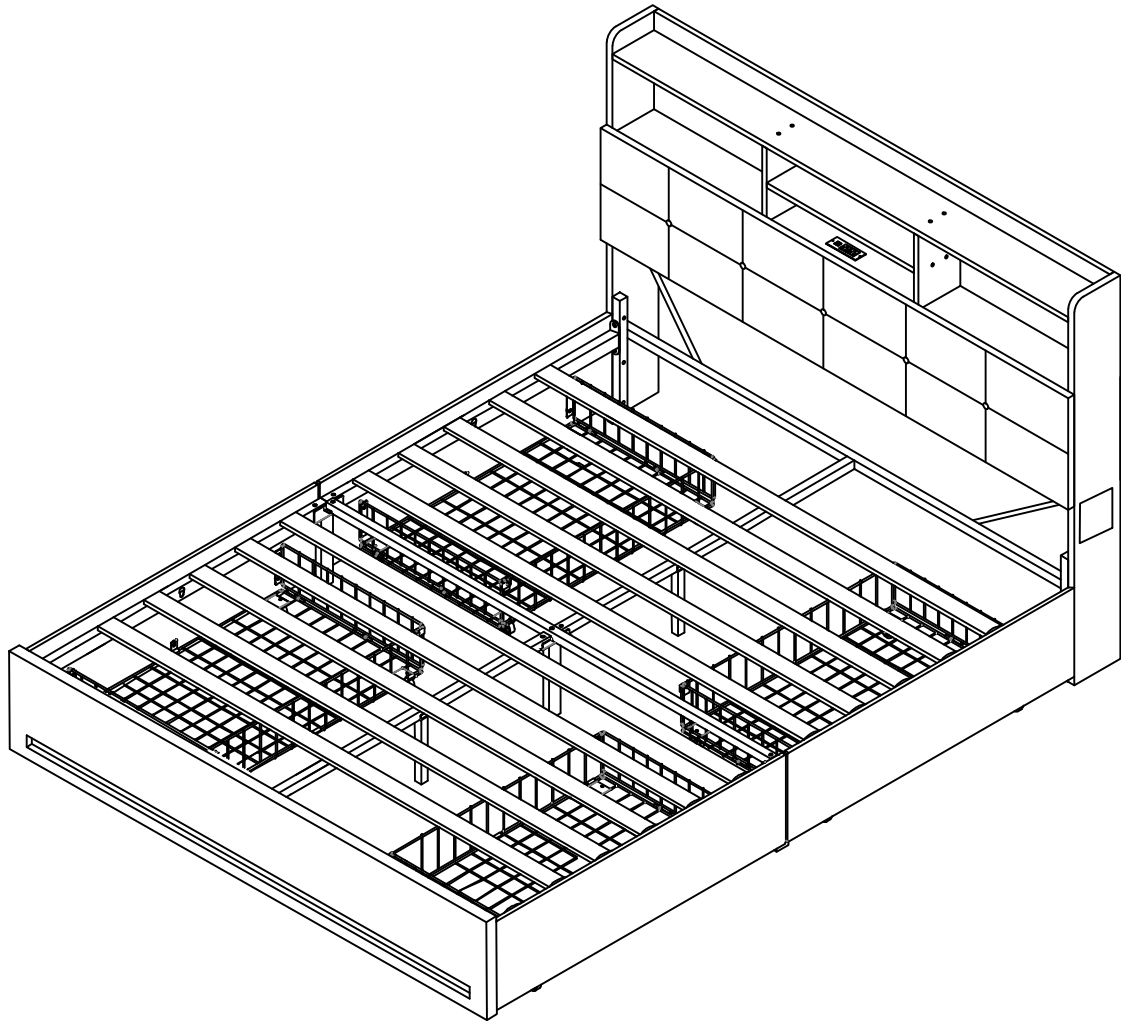

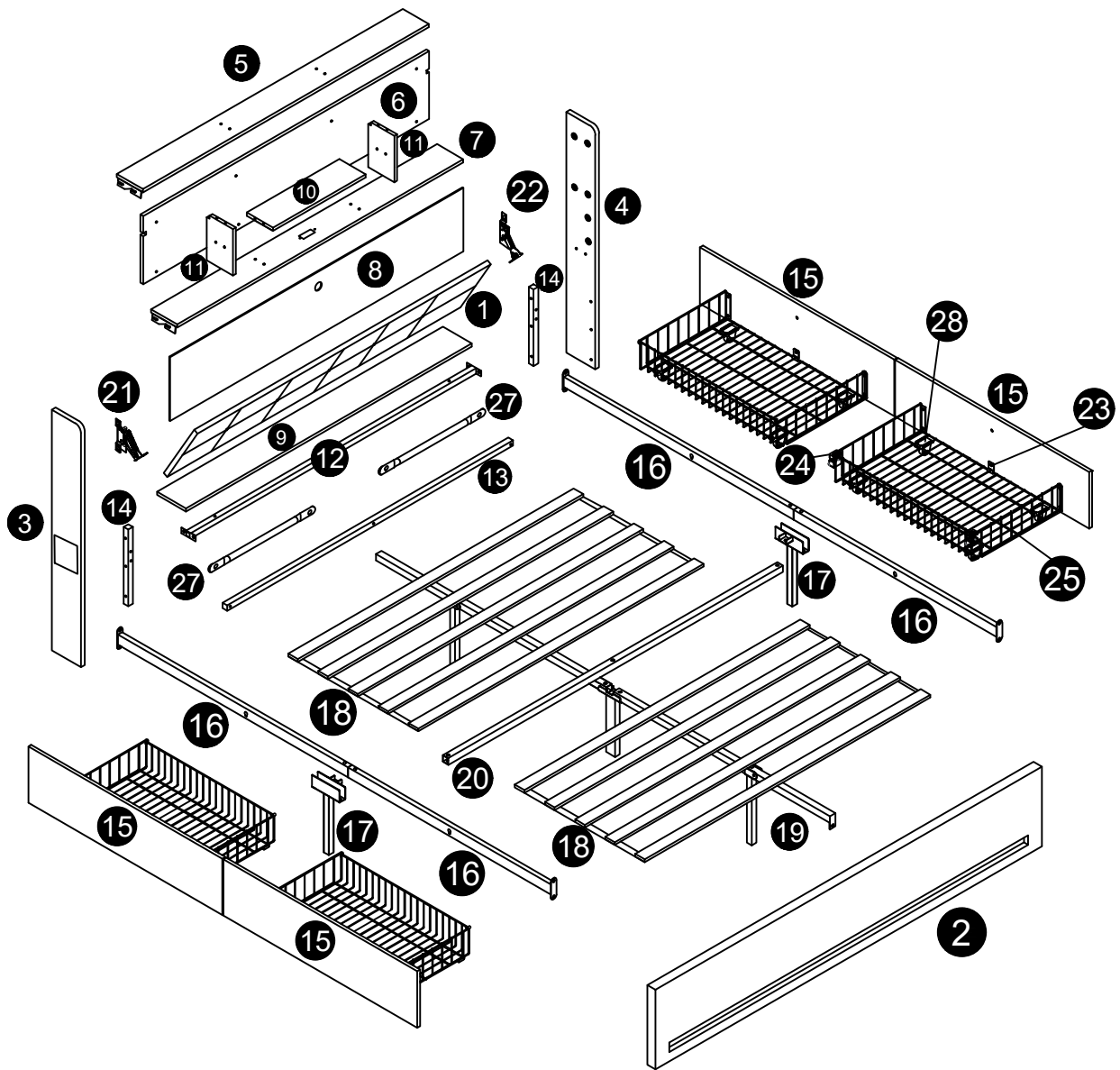

DJ504526

DJ504527



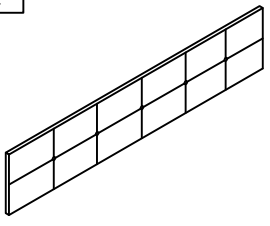
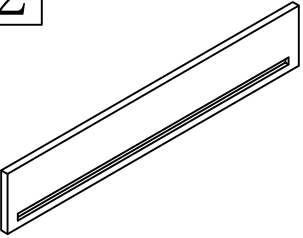

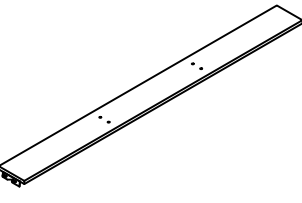
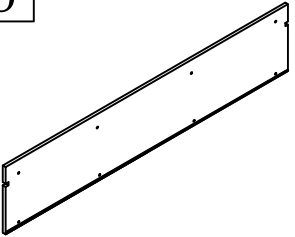
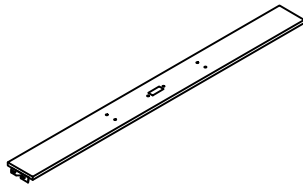
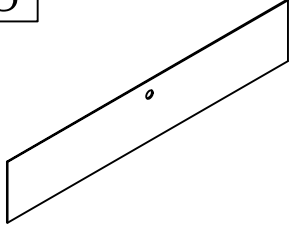
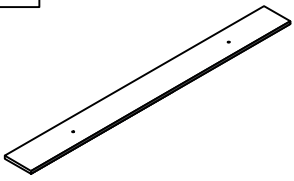
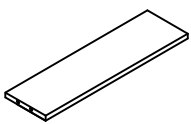
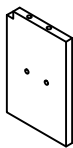
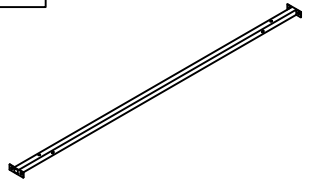
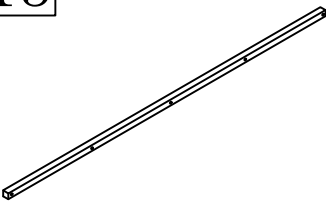
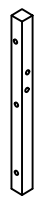
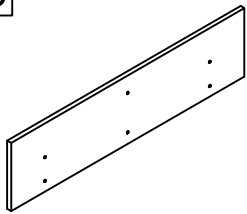
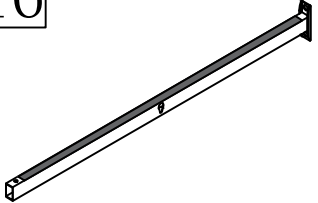
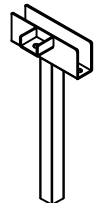
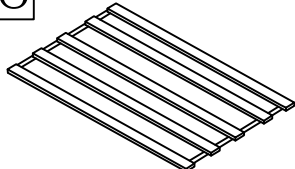
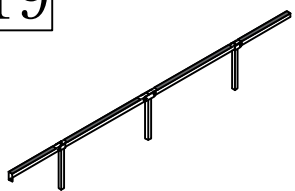
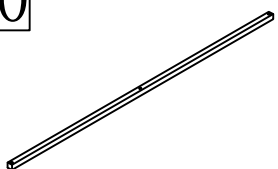
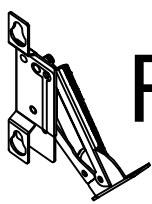

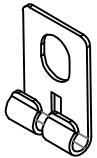
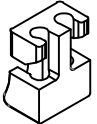



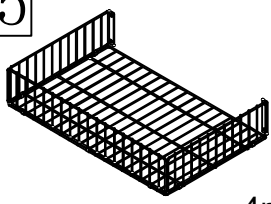
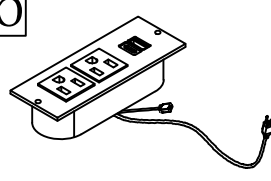
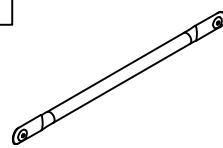
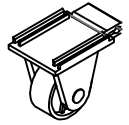
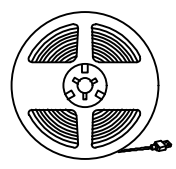

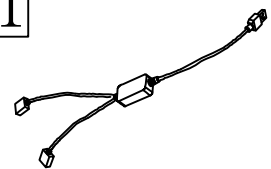
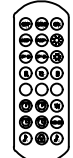
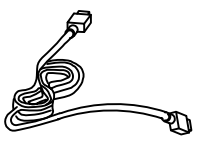
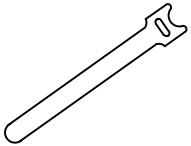

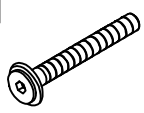

Part list

<p>1</p>  <p>1pc</p>	<p>2</p>  <p>1pc</p>	<p>3</p>  <p>1pc</p>	<p>4</p>  <p>1pc</p>
<p>5</p>  <p>1pc</p>	<p>6</p>  <p>1pc</p>	<p>7</p>  <p>1pc</p>	<p>8</p>  <p>1pc</p>
<p>9</p>  <p>1pc</p>	<p>10</p>  <p>1pc</p>	<p>11</p>  <p>2pcs</p>	<p>12</p>  <p>1pc</p>
<p>13</p>  <p>1pc</p>	<p>14</p>  <p>2pcs</p>	<p>15</p>  <p>4pcs</p>	<p>16</p>  <p>4pcs</p>
<p>17</p>  <p>2pcs</p>	<p>18</p>  <p>2pcs</p>	<p>19</p>  <p>1pc</p>	<p>20</p>  <p>1pc</p>
<p>21</p>  <p>R</p> <p>1PC</p>	<p>22</p>  <p>L</p> <p>1PC</p>	<p>23</p>  <p>4pcs</p>	<p>24</p>  <p>8pcs</p>

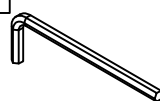

Part list

<p>25</p>  <p>4pcs</p>	<p>26</p>  <p>1pc</p>	<p>27</p>  <p>2pcs</p>	<p>28</p>  <p>16pcs</p>
<p>29</p>  <p>long</p> <p>1pc</p>	<p>30</p>  <p>short</p> <p>1pc</p>	<p>31</p>  <p>1pc</p>	<p>32</p>  <p>1pc</p>
<p>33</p>  <p>1pc</p>	<p>34</p>  <p>5pcs</p>		

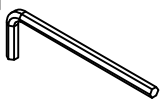
Hardware list

<p>A</p>  <p>M8*50mm</p> <p>6pcs</p>	<p>B</p>  <p>M8*35mm</p> <p>16pcs</p>	<p>C</p>  <p>M8*20mm</p> <p>18pcs</p>	<p>D</p>  <p>M8*15mm</p> <p>5pcs</p>	<p>E</p>  <p>M6*12mm</p> <p>22pcs</p>
<p>F</p>  <p>M6*20mm</p> <p>4pcs</p>	<p>G</p>  <p>M5*30mm</p> <p>22PCS</p>	<p>H</p>  <p>M4*12mm</p> <p>3pcs</p>	<p>I</p>  <p>M4*65MM</p> <p>1pc</p>	<p>J</p>  <p>M5*65MM</p> <p>1pc</p>
<p>K</p>  <p>M3*65MM</p> <p>1pc</p>				

Step1

H		M4x12mm	2pcs
J		M5*65	1pc

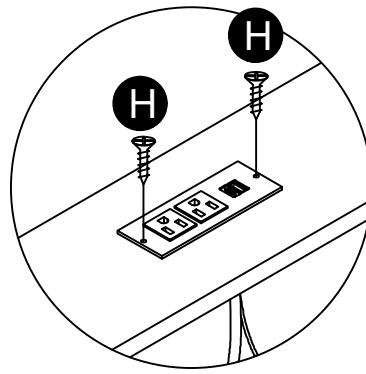
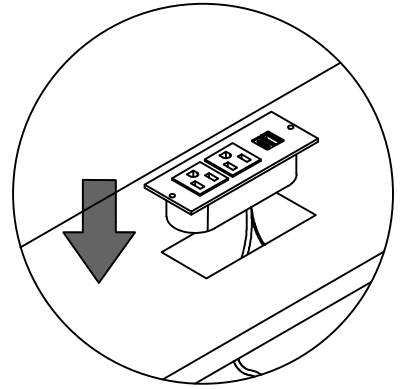
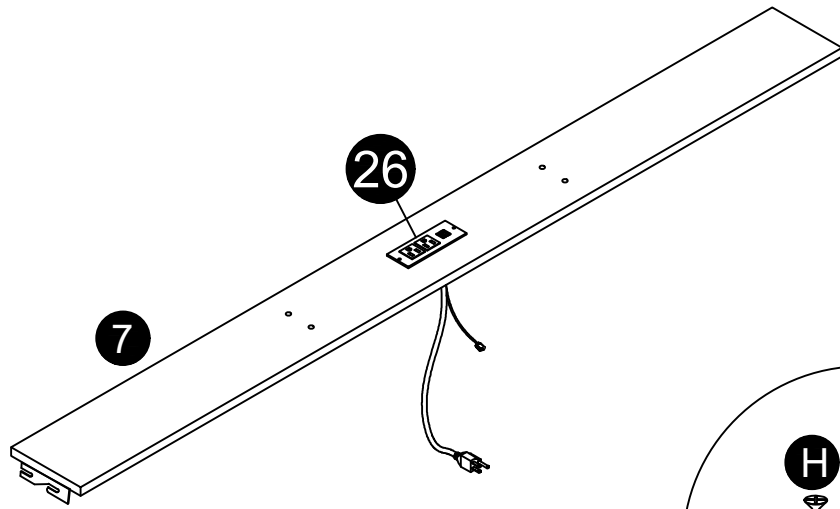

Step2

J		M5*65	1pc
---	---	-------	-----

29 Lamp strip 29 is glued onto board 5



Unfold the light strip and secure it

Hole up

Note: Velcro is facing backwards.

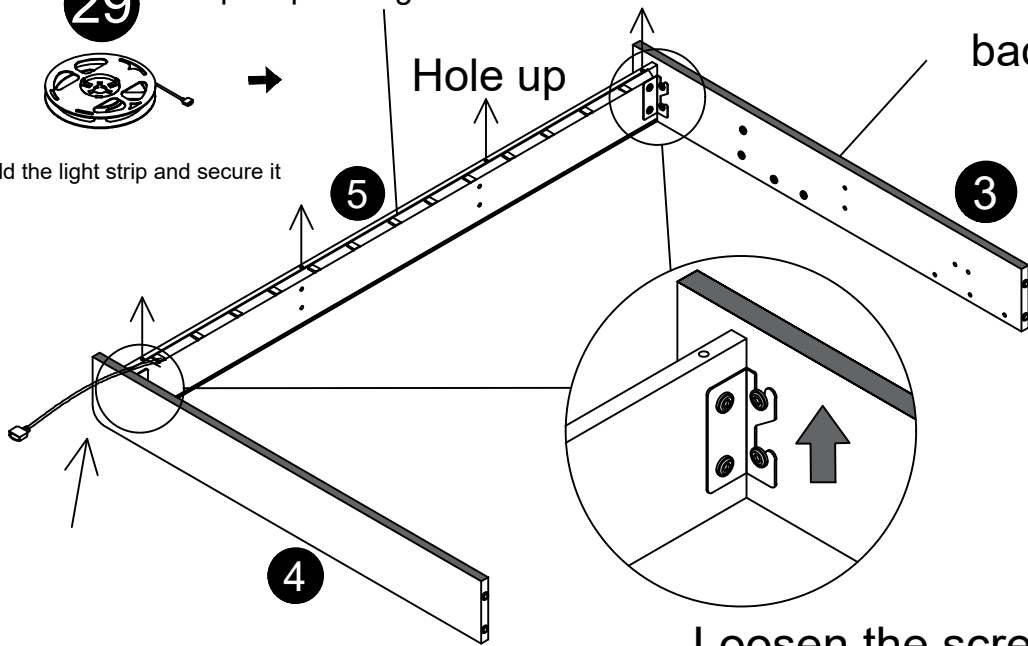

Loosen the screws on the side board, hang the brackets and tighten the screws. 5 OF 18

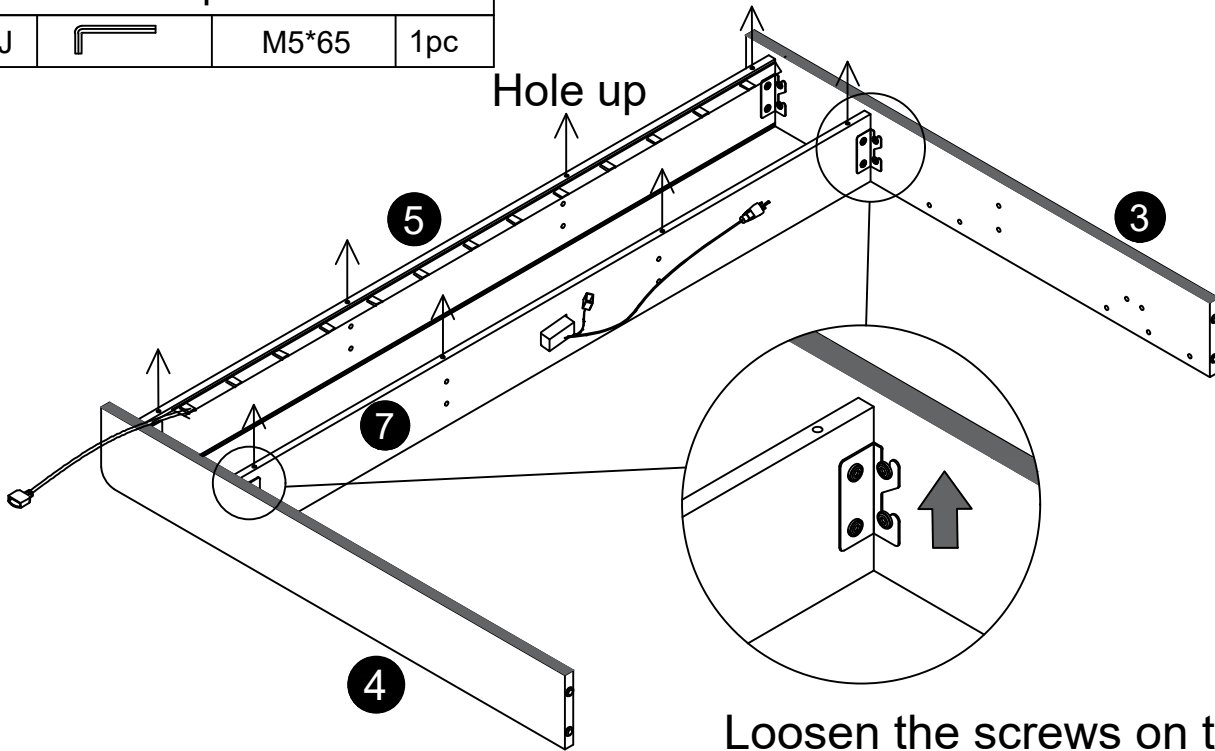

Step3

J		M5*65	1pc
---	---	-------	-----



Loosen the screws on the side board, hang the brackets and tighten the screws.

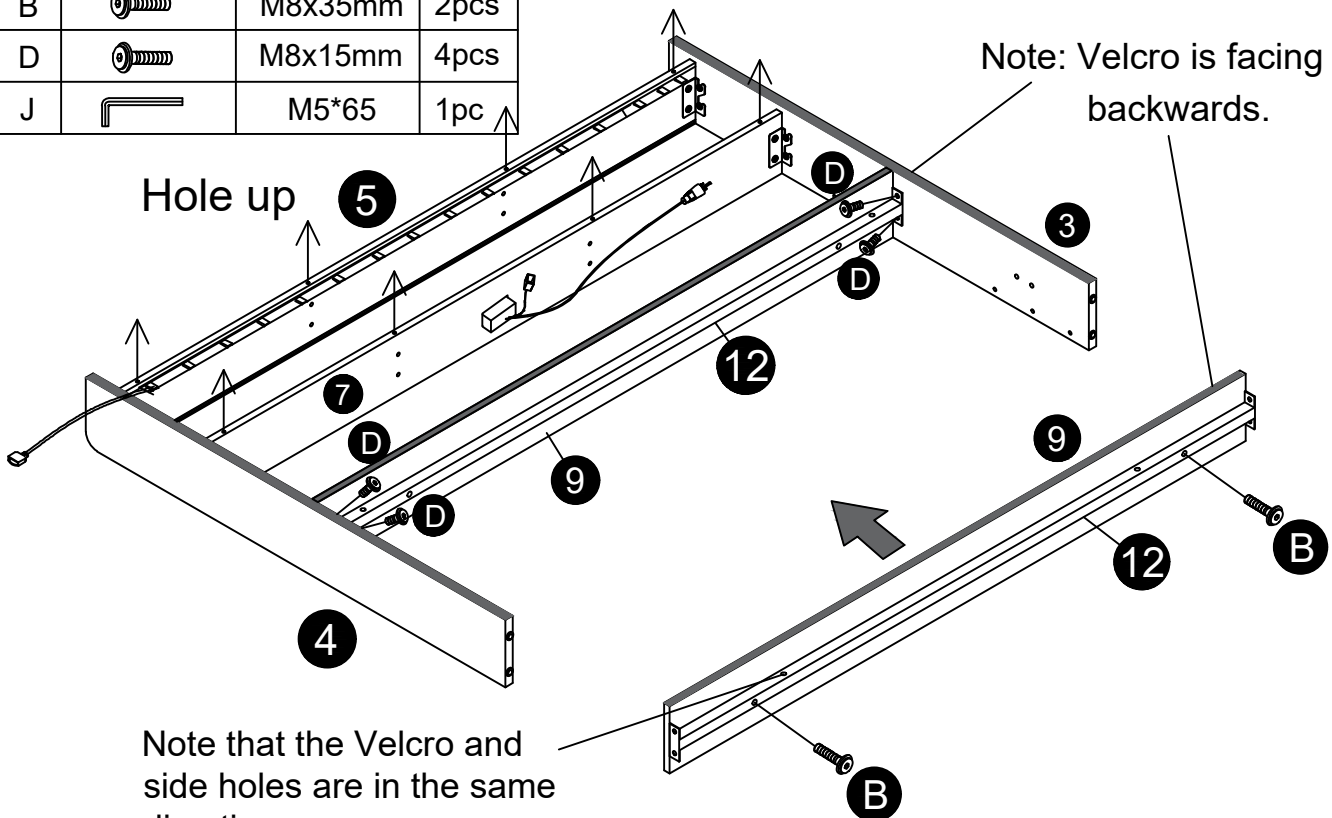

Step4

B		M8x35mm	2pcs
D		M8x15mm	4pcs
J		M5*65	1pc





Note that the Velcro and side holes are in the same direction

Step5

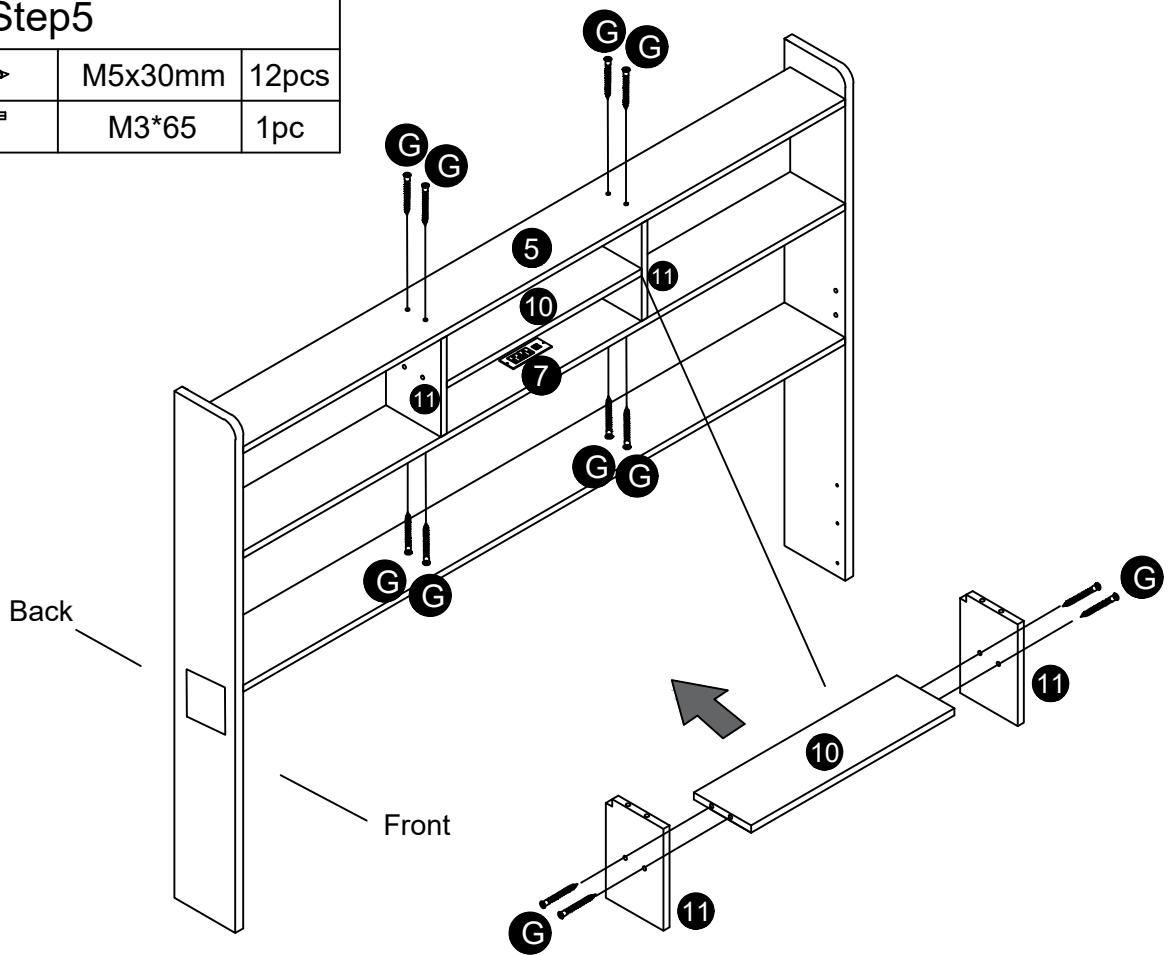
G		M5x30mm	12pcs
K		M3*65	1pc



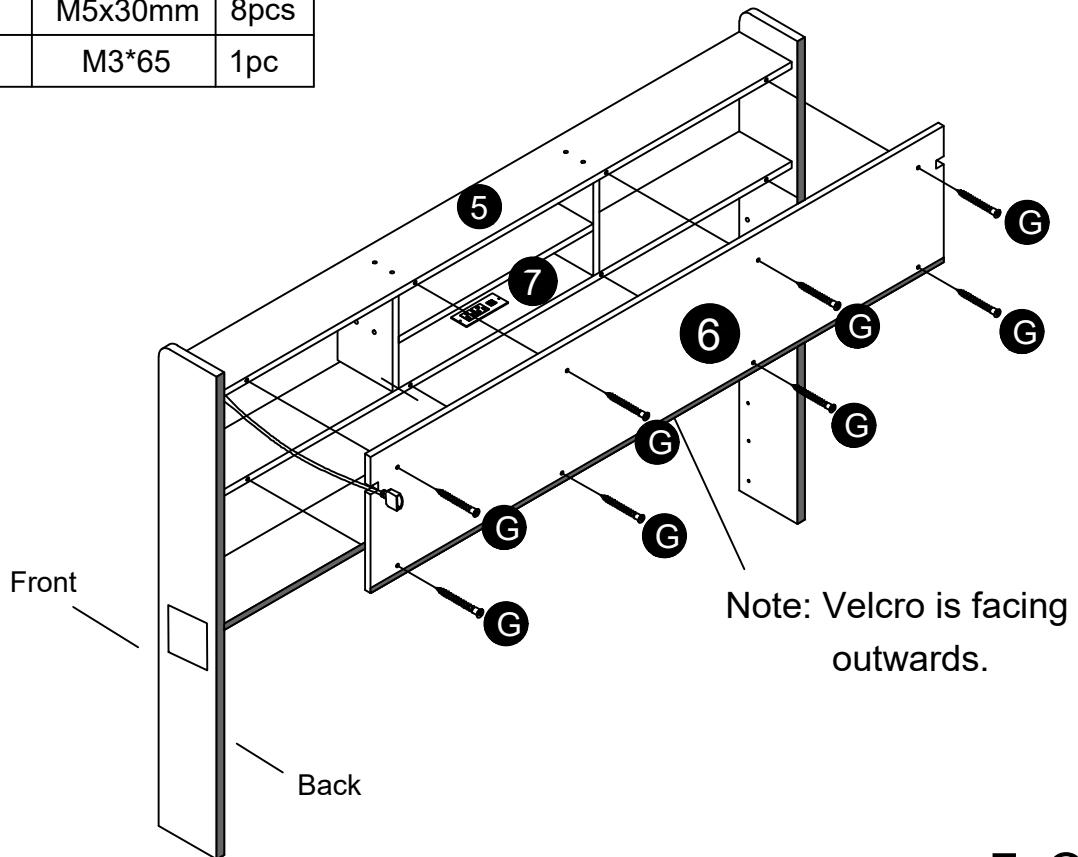

Step6

G		M5x30mm	8pcs
K		M3*65	1pc



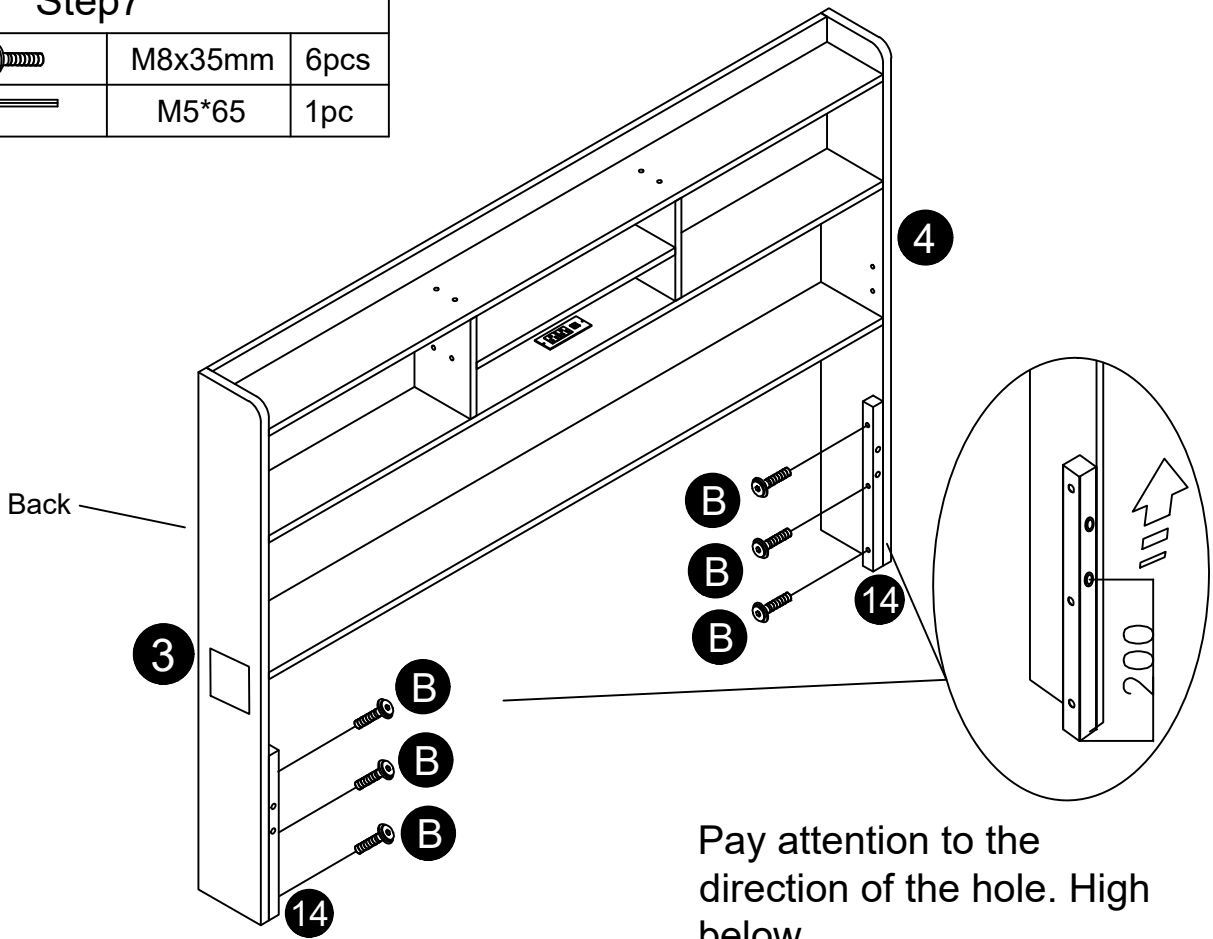

Step7

B		M8x35mm	6pcs
J		M5*65	1pc



Pay attention to the direction of the hole. High below

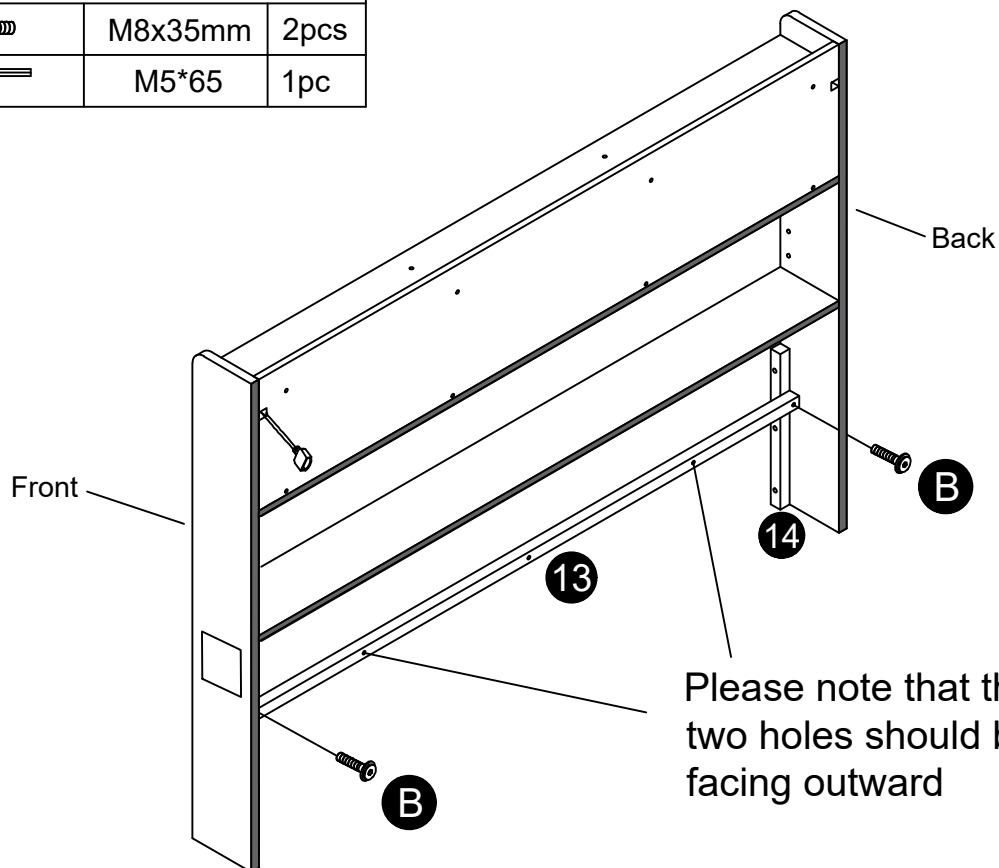

Step8

B		M8x35mm	2pcs
J		M5*65	1pc



Please note that these two holes should be facing outward

Step9

C		M8x20mm	4pcs
J		M5*65	1pc

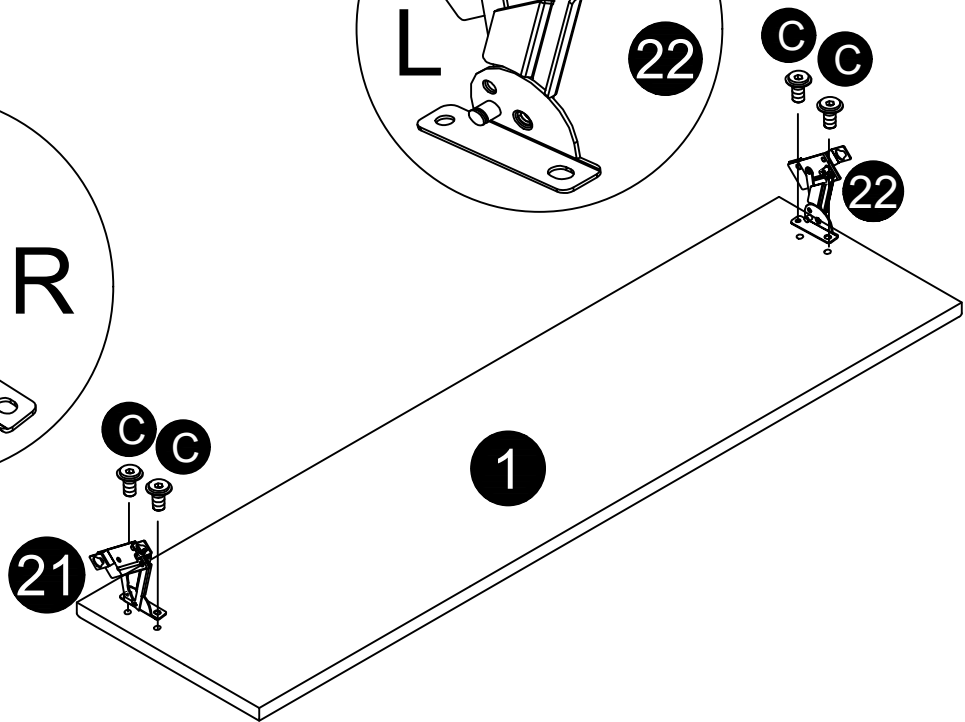
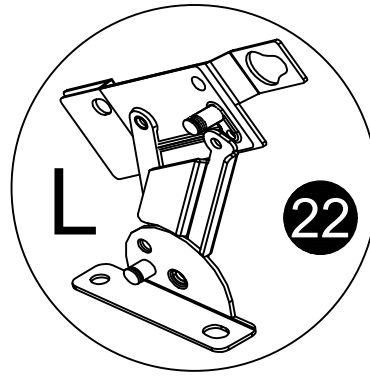
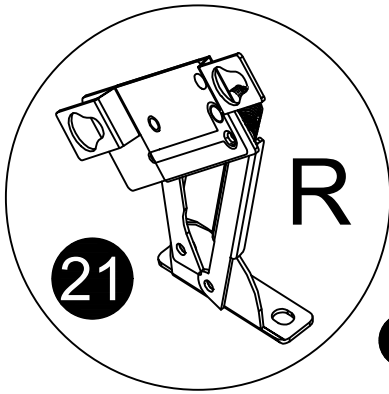

Step10

J		M5*65	1pc
---	---	-------	-----



RECOMMEND 2 OR MORE ADULTS
FOR QUICKER ASSEMBLY

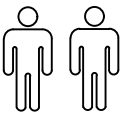

2PERS

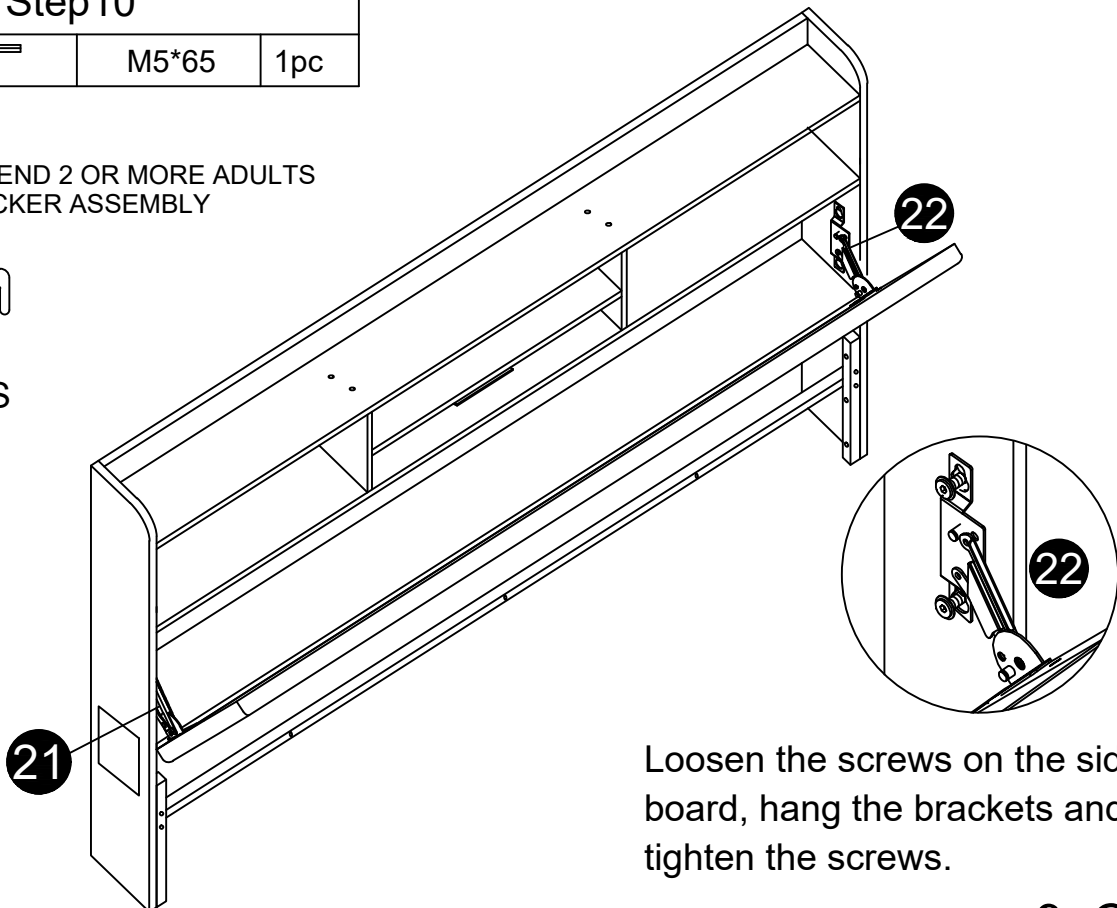

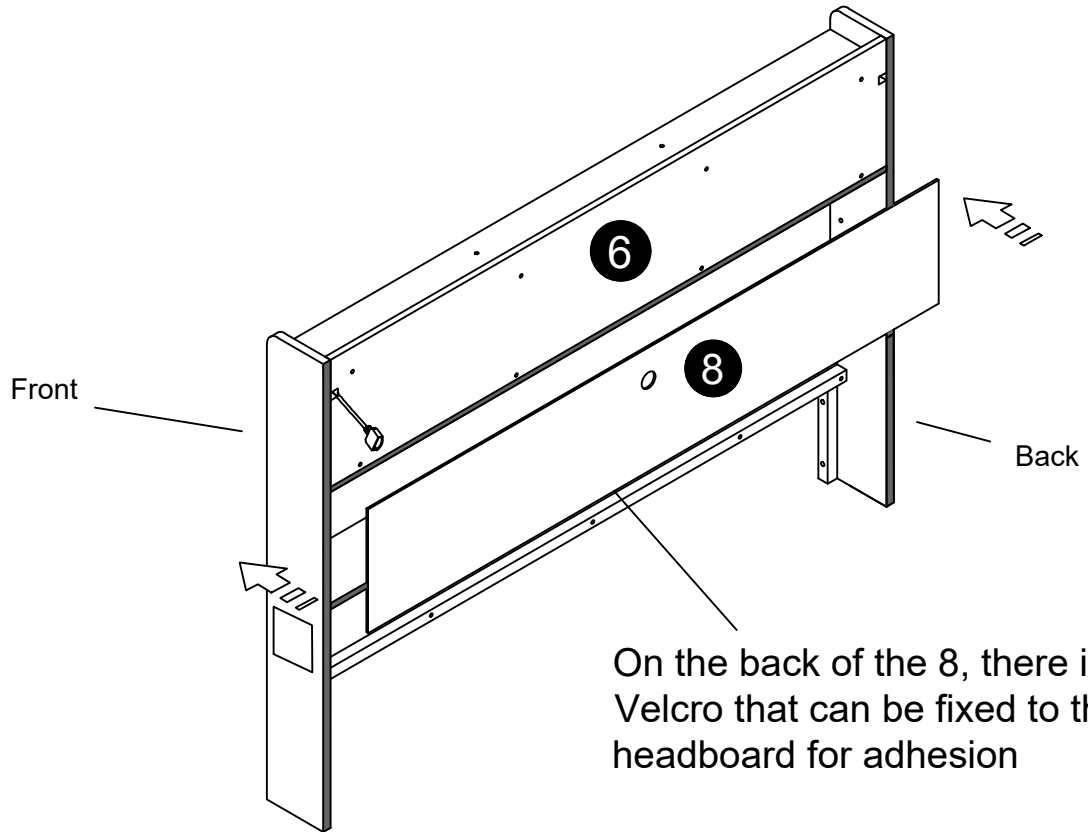

Loosen the screws on the side board, hang the brackets and tighten the screws.

Step11



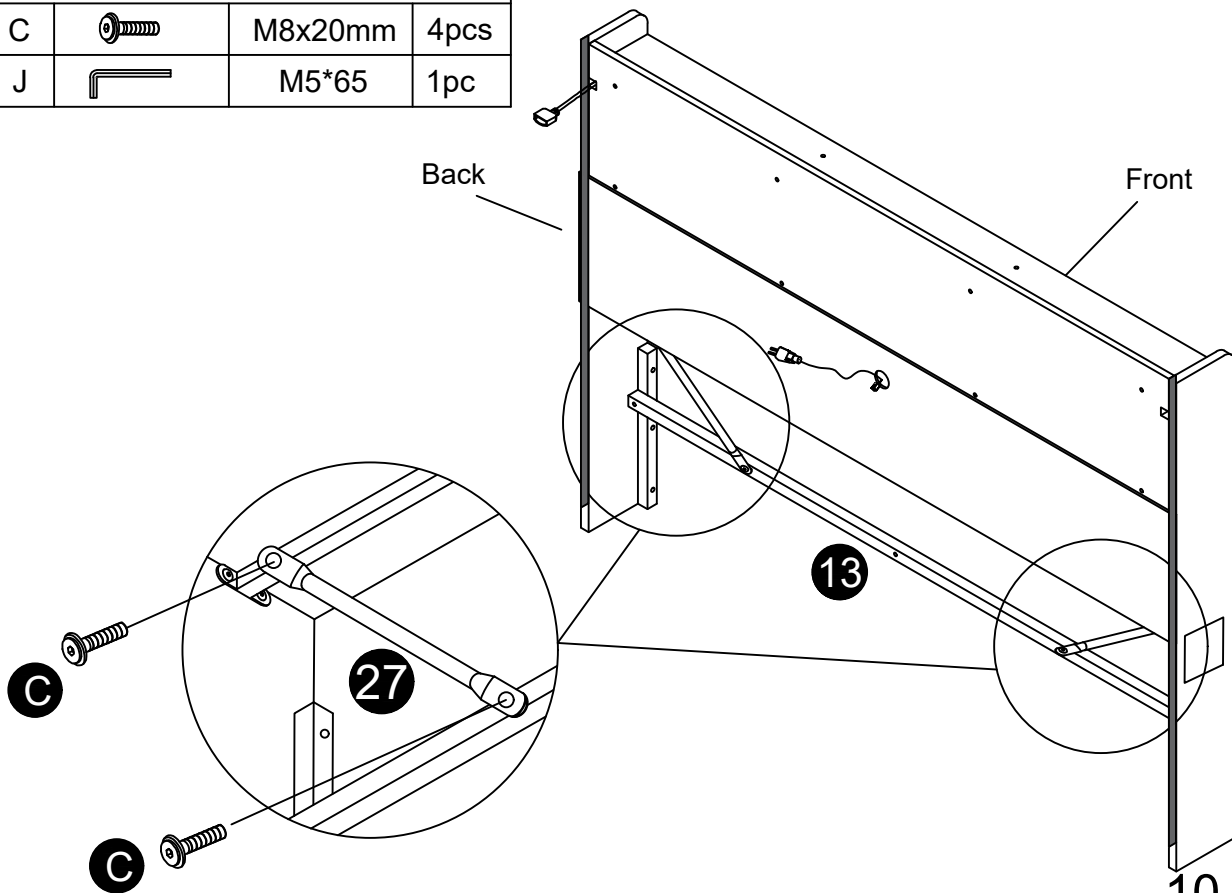

Step12

C		M8x20mm	4pcs
J		M5*65	1pc



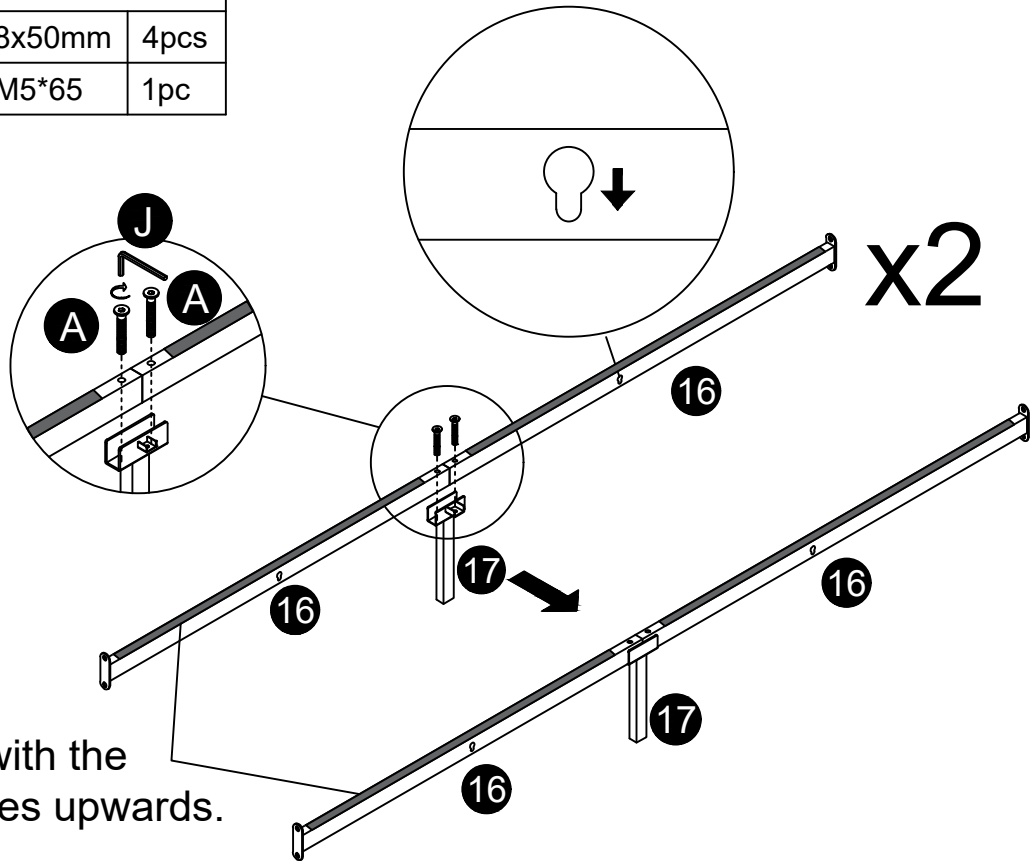

Step13

A		M8x50mm	4pcs
J		M5*65	1pc



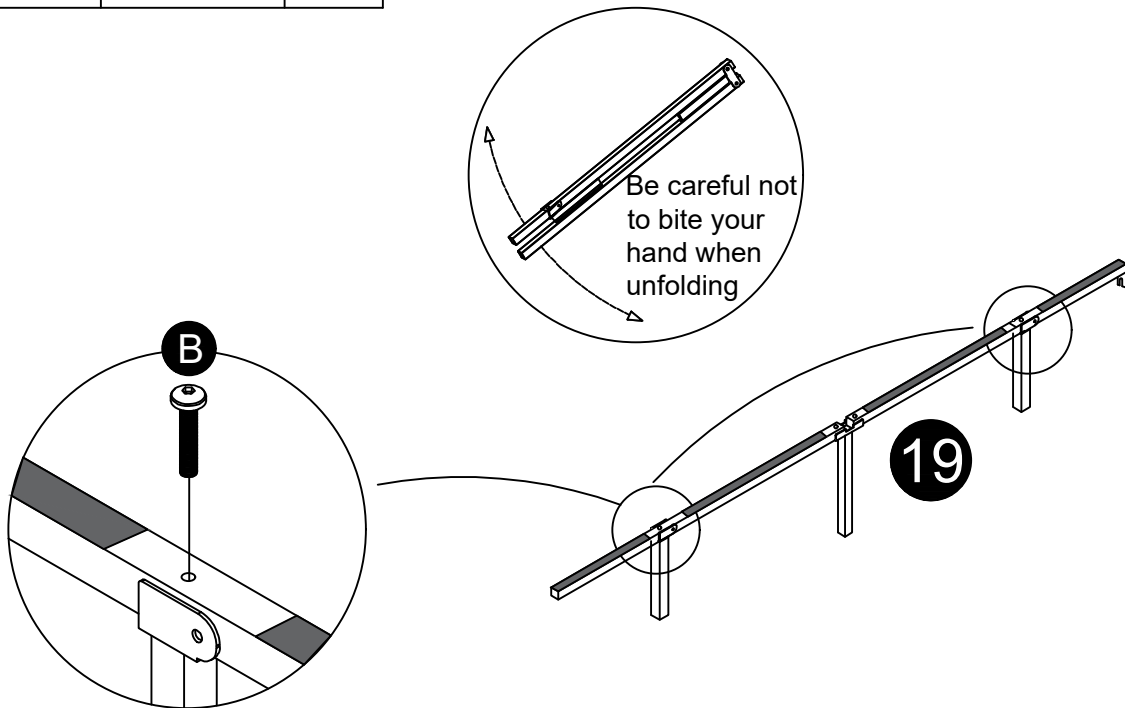

Step14

B		M8x35mm	2pcs
J		M5*65	1pc



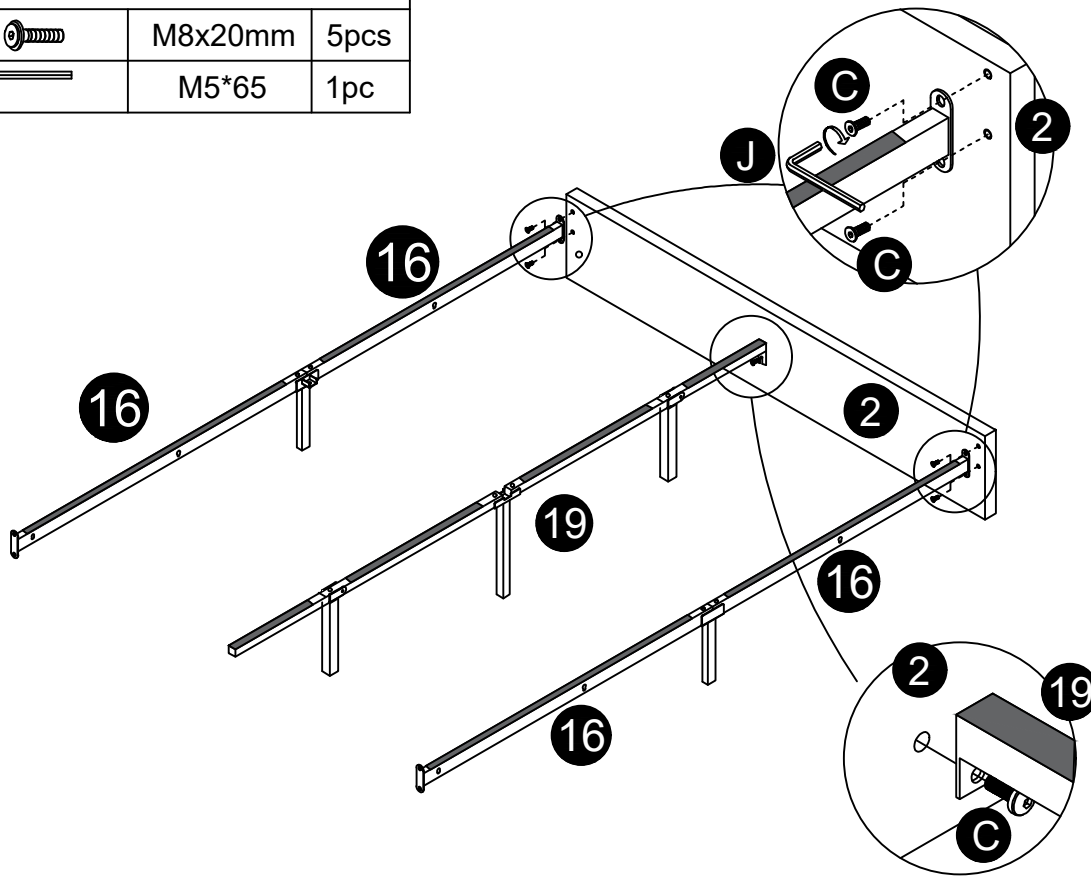

Step 15

C		M8x20mm	5pcs
J		M5*65	1pc



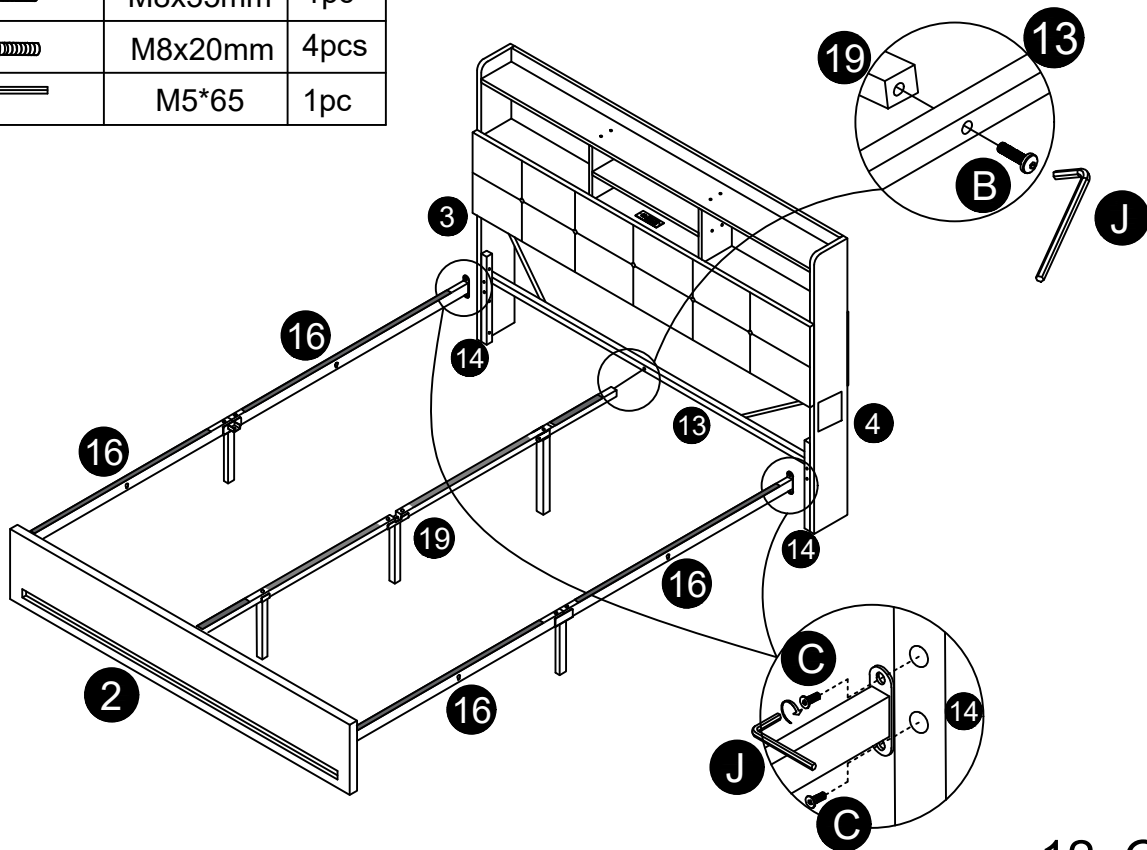

Step 16

B		M8x35mm	1pc
C		M8x20mm	4pcs
J		M5*65	1pc



Step 17

A		M8x50mm	1pc
B		M8x35mm	2pcs
J		M5*65	1pc

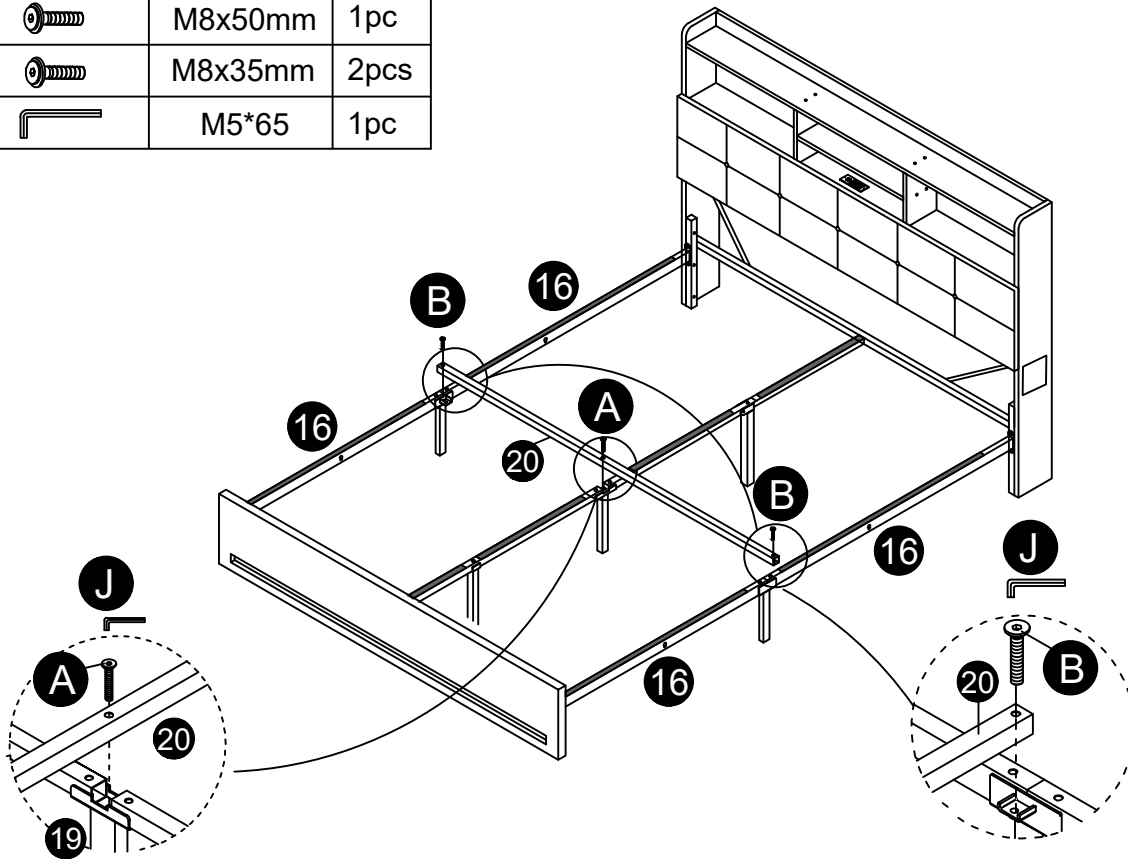

Step 18

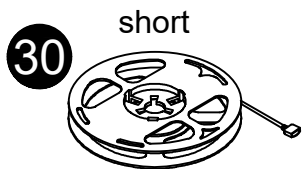

The 30th light strip is inserted from the inside of the 2nd bed tail

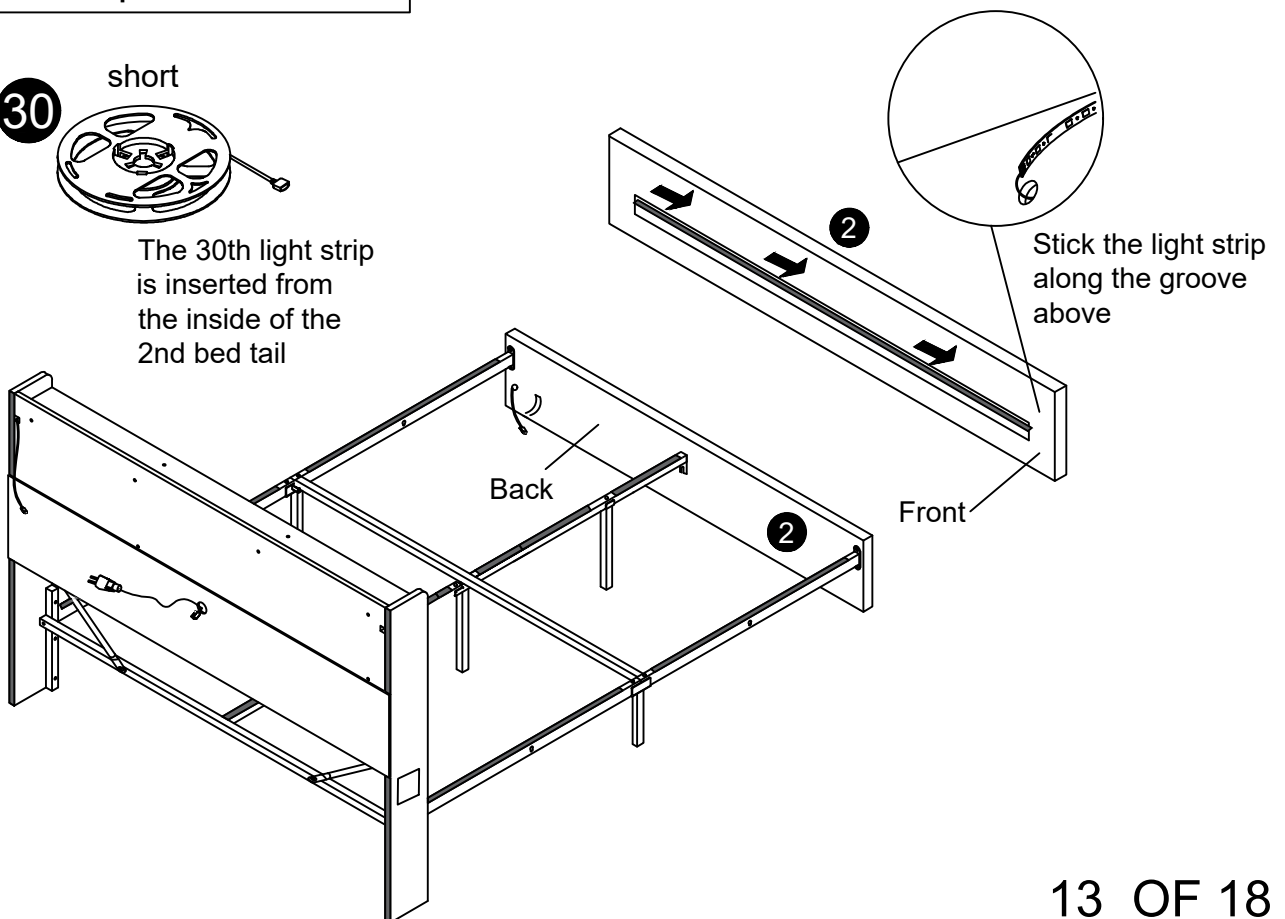

Step19

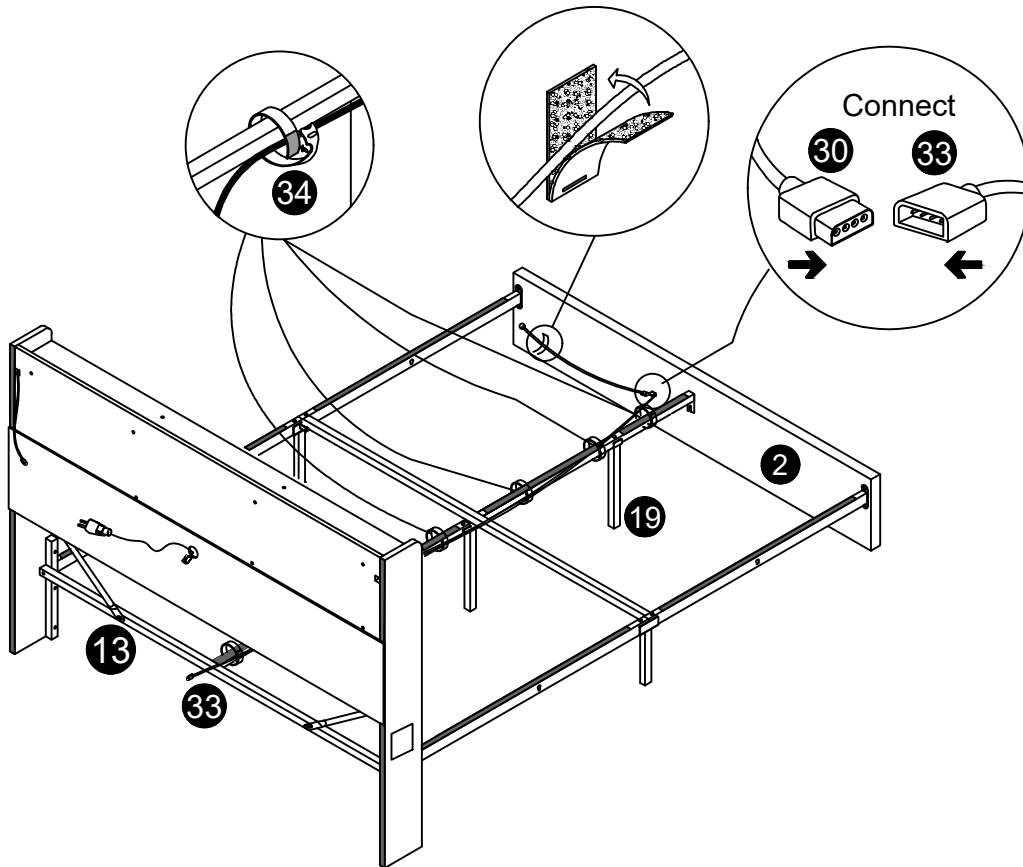

Step20

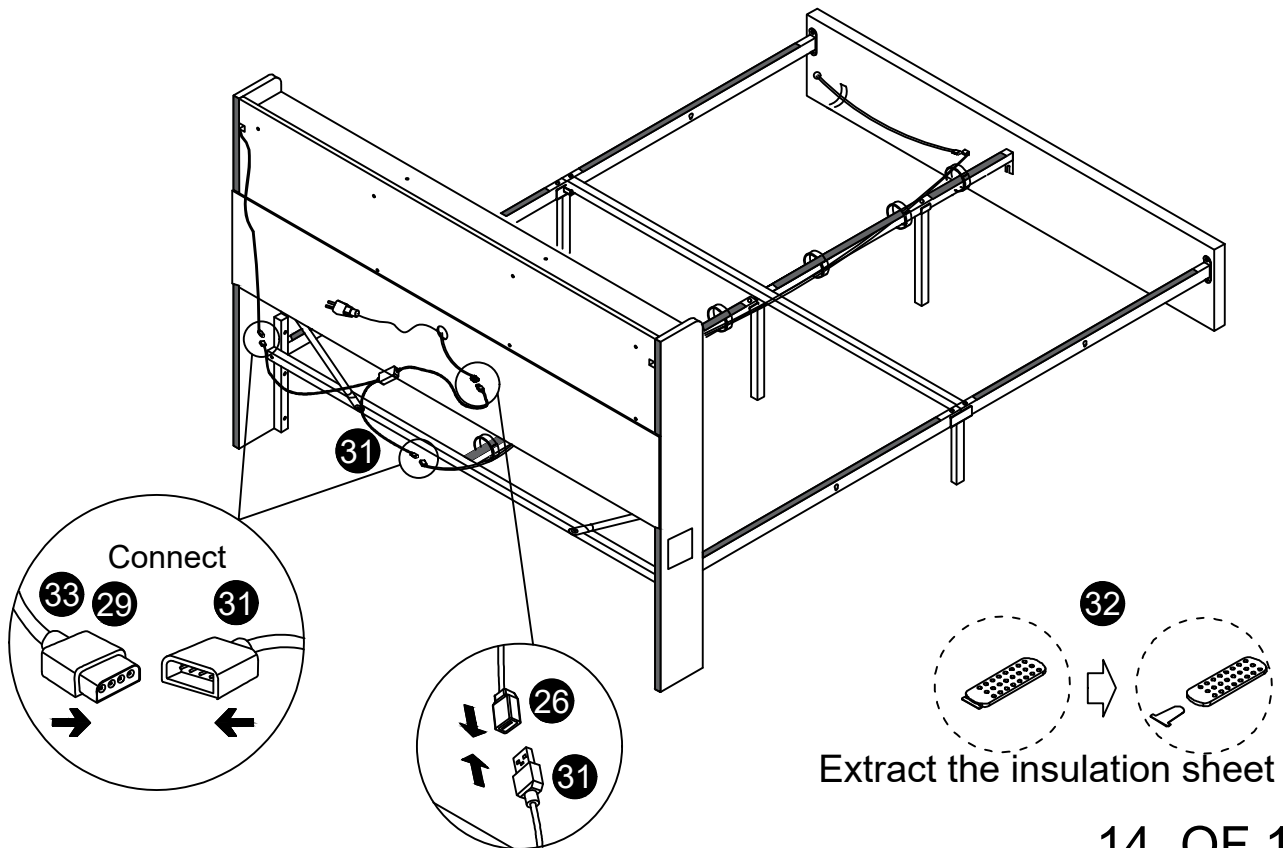

Step21

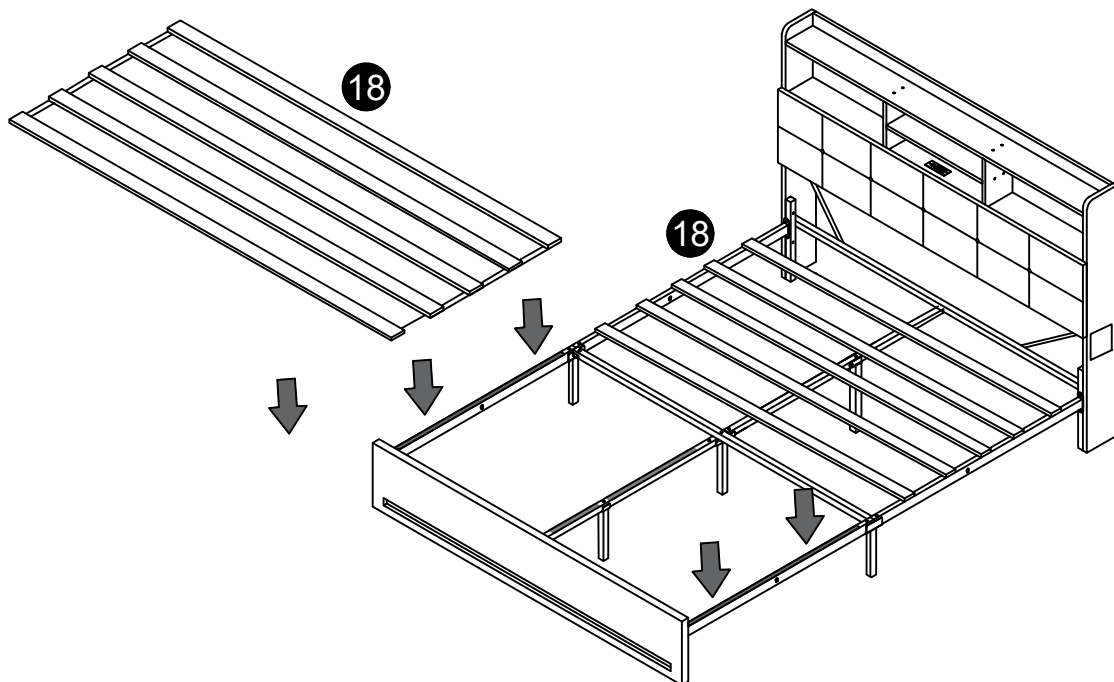

Step22

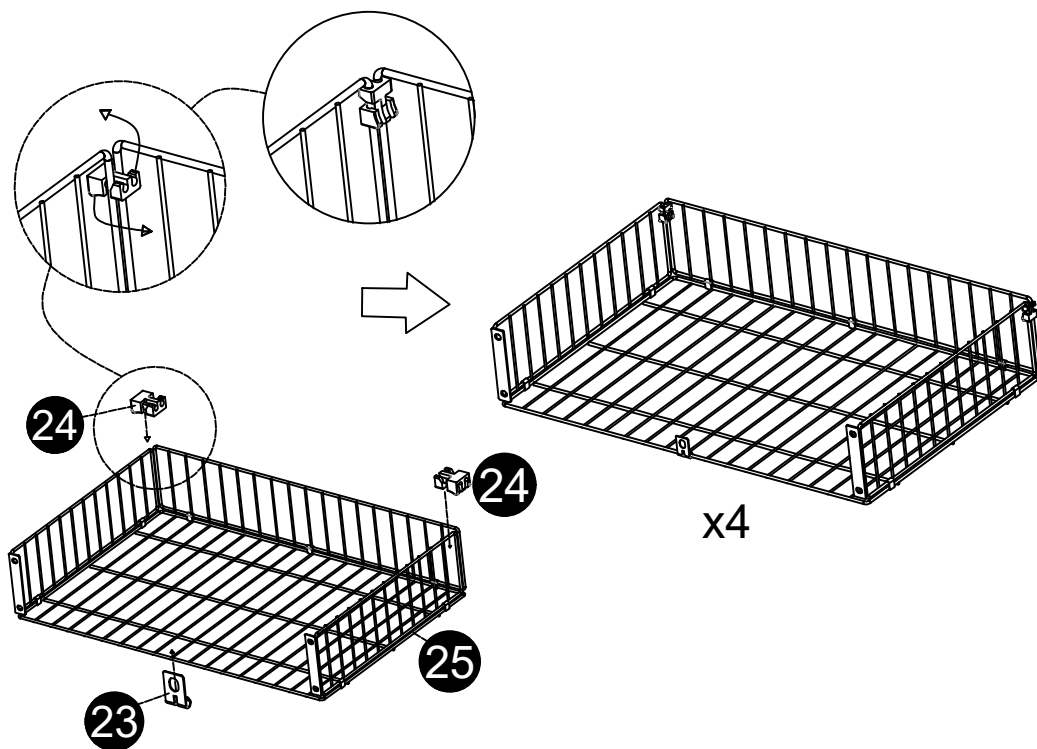

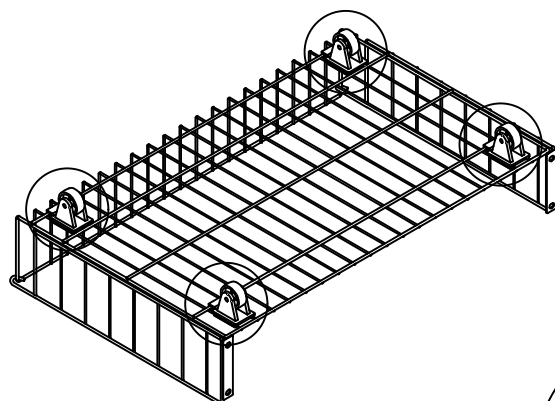

Step23

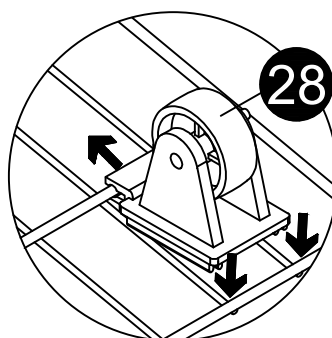

x4



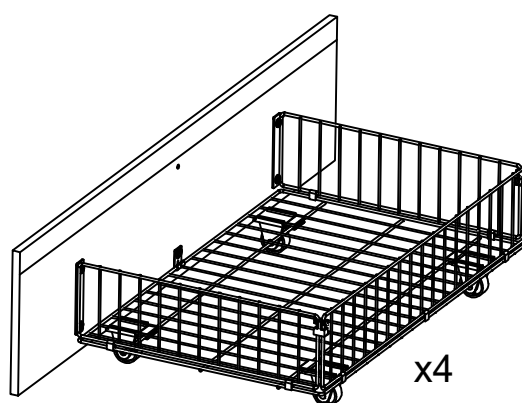
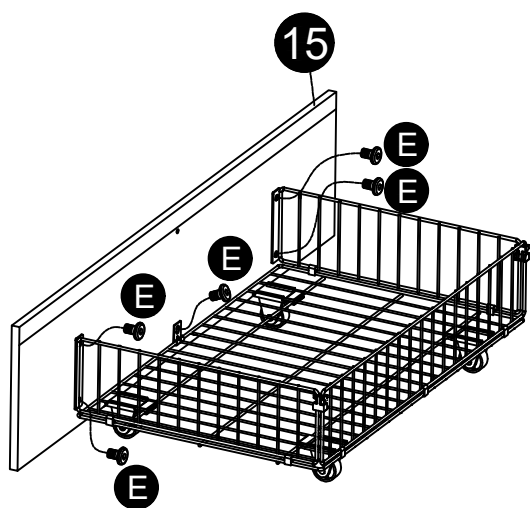

Step24

E		M6x12mm	20pcs
I		M4*65	1pc



Step25

F		M6x20mm	4pcs
I		M4*65	1pc

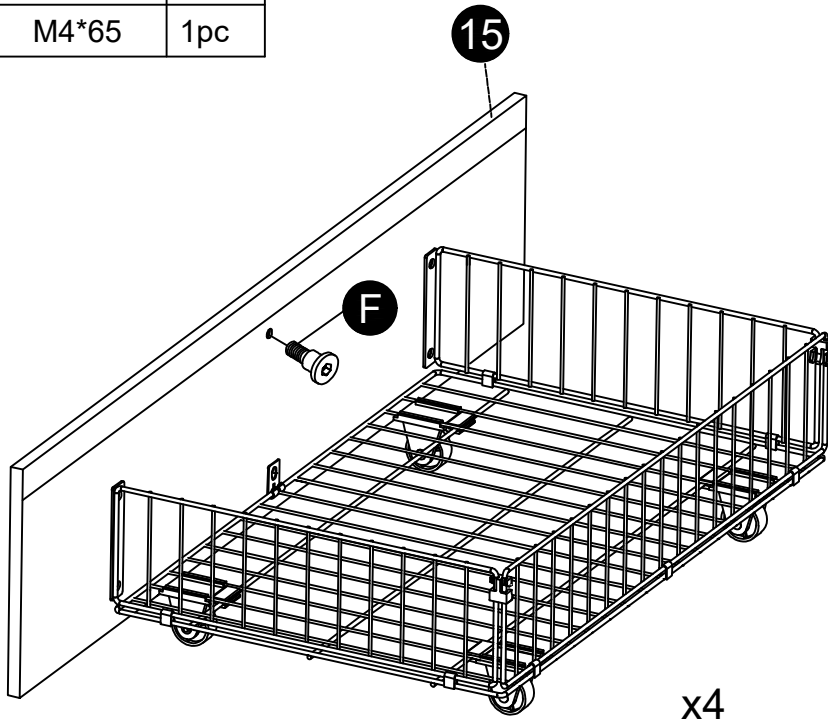

Step26

