

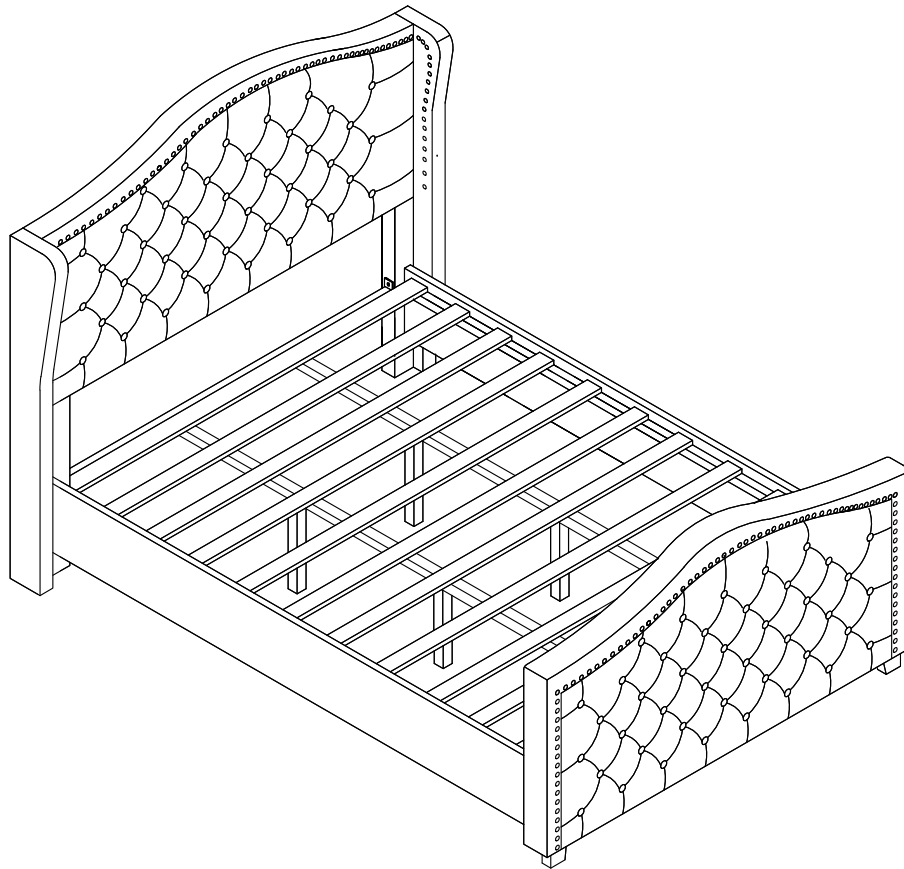









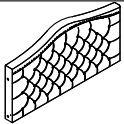

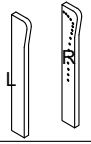

ASSEMBLY INSTRUCTION

ITEM NO: 510&520&530-CKING&EKING

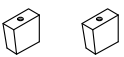
IMPORTANT: PLACE ALL PARTS ON A CLEAN AND SMOOTH SURFACE SUCH AS A RUG OR CARPET TO AVOID THE PARTS FROM BEING SCRATCHED
KINDLY FOLLOW THE ASSEMBLY INSTRUCTIONS STEP
DO NOT TIGHTEN ALL SCREWS UNTIL THE BED IS FULLY SET-UP

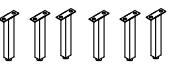

Bed is packed in 2 carton

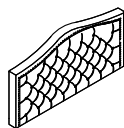
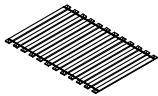
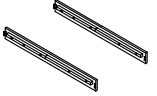
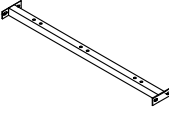
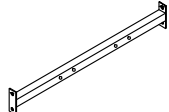
Carton	Disignation	Part	Hardware
(1/2)	1.Headboard		 #A x 1PC
	4.Wingback(2pcs)		 #B x 16PCS  #C x 26PCS  #D x 2PCS
	5.HB Leg(2pcs)		 #E x 62PCS
	6.FB Feet(2pcs)		 #F x 10PCS  #G x 32PCS
	7.Support Leg(6pcs)		 #H x 24PCS  #I x 16PCS  #J x 1PC
	2.Footboard		
	7.Slats(12pcs)		
(2/2)	3.Side rail(2pcs)		
	8.Support rail(2pcs)		
	9.Crossband		

STEP 1

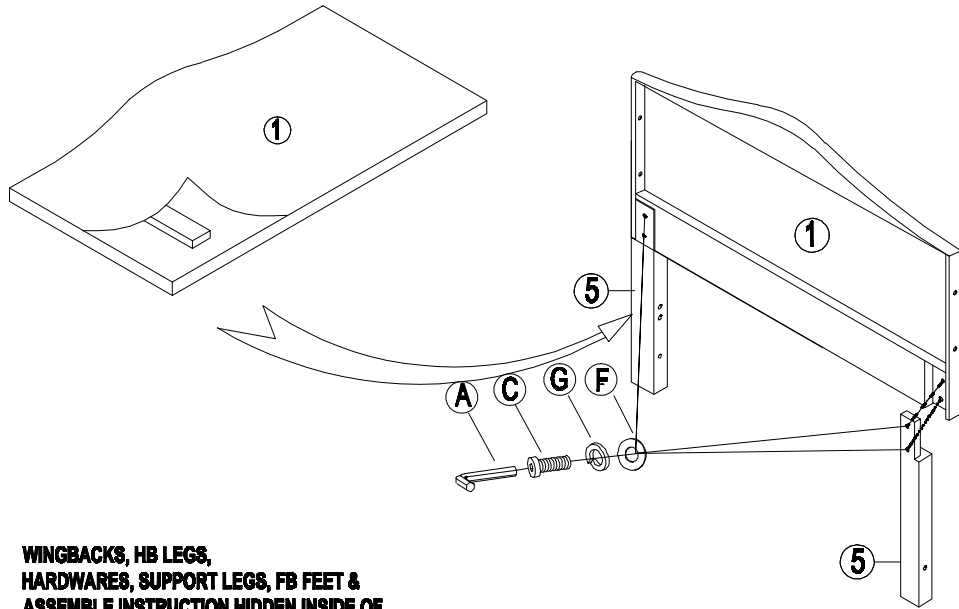

WINGBACKS, HB LEGS,
HARDWARES, SUPPORT LEGS, FB FEET &
ASSEMBLE INSTRUCTION HIDDEN INSIDE OF
THE HEADBOARD, PLZ LIFT THE COVER .

STEP 2

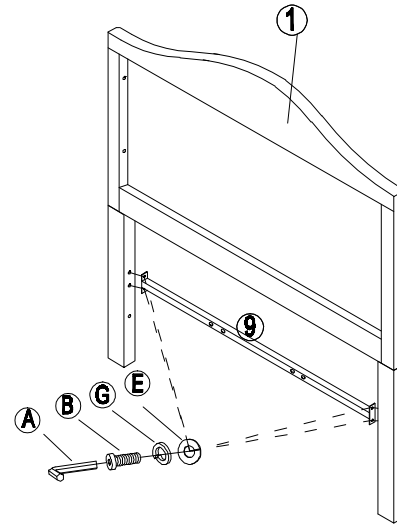

STEP 3

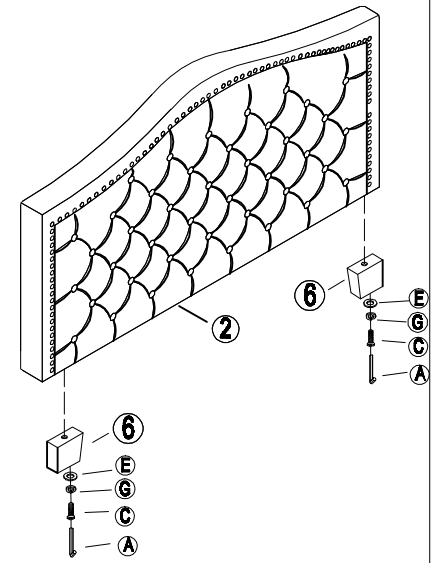

STEP 4

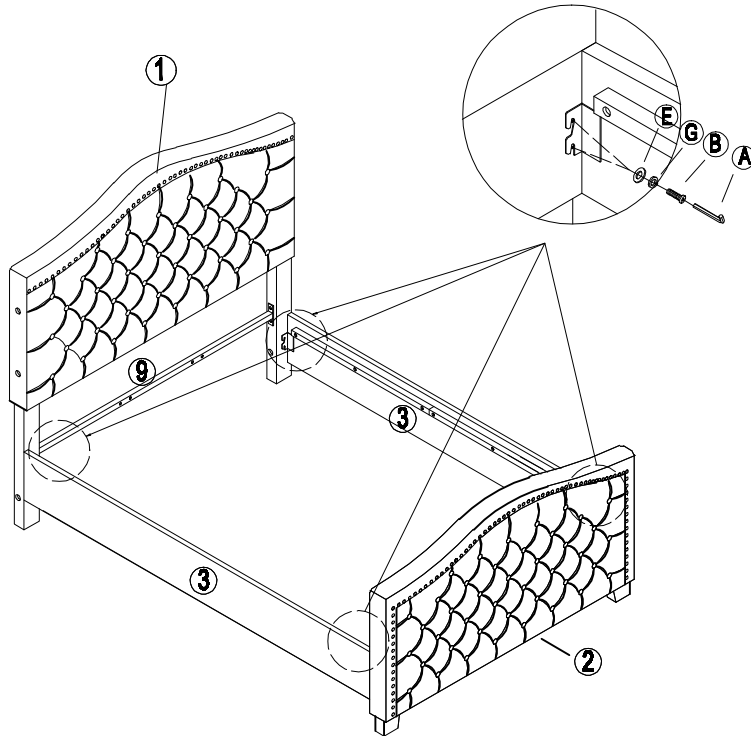

STEP 5

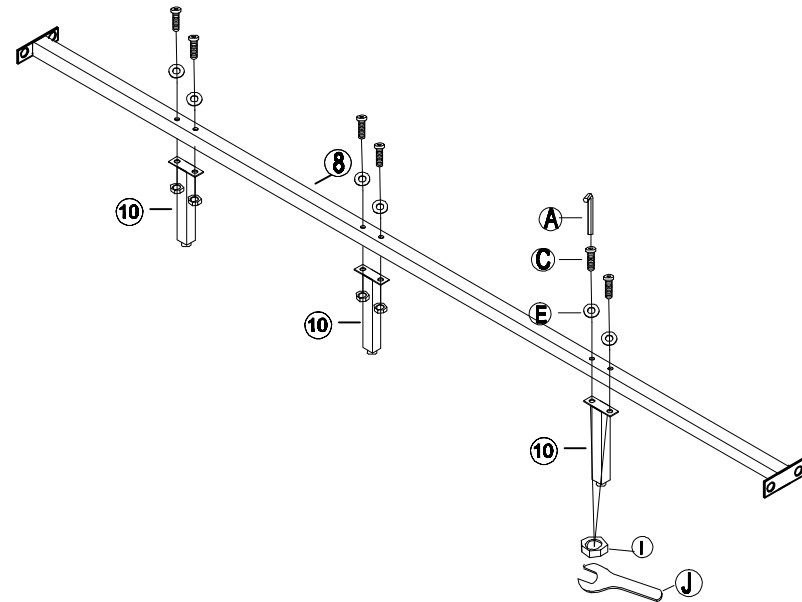

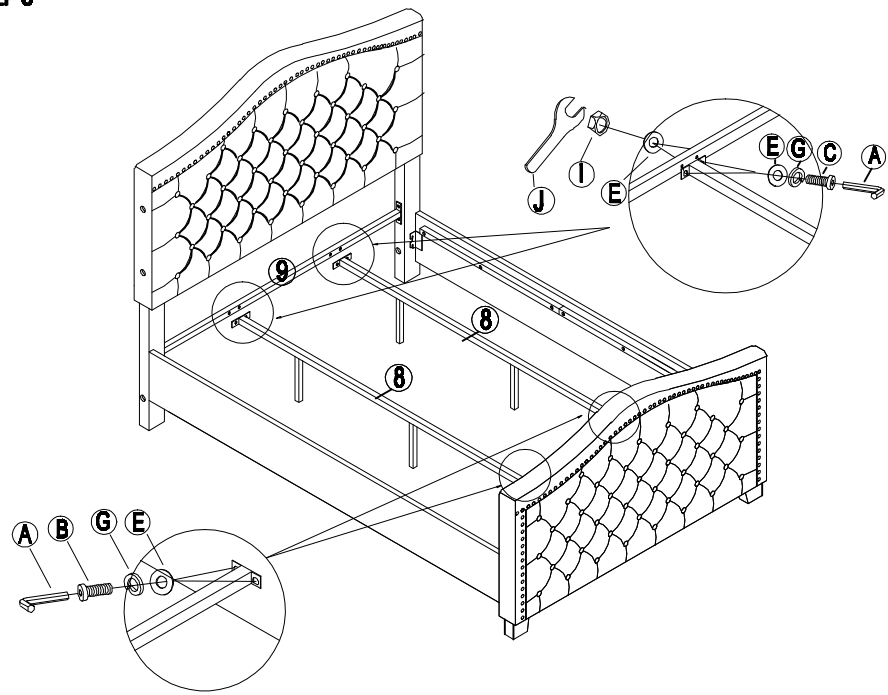
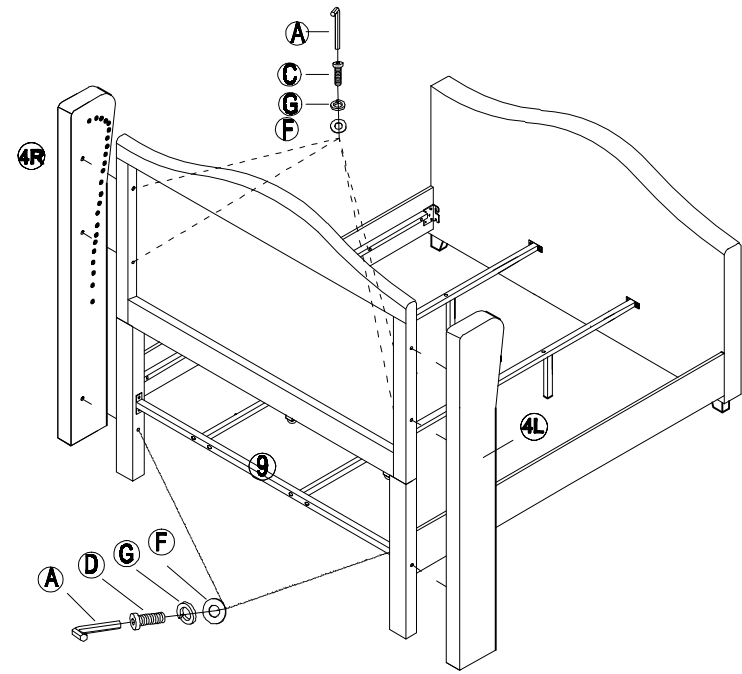
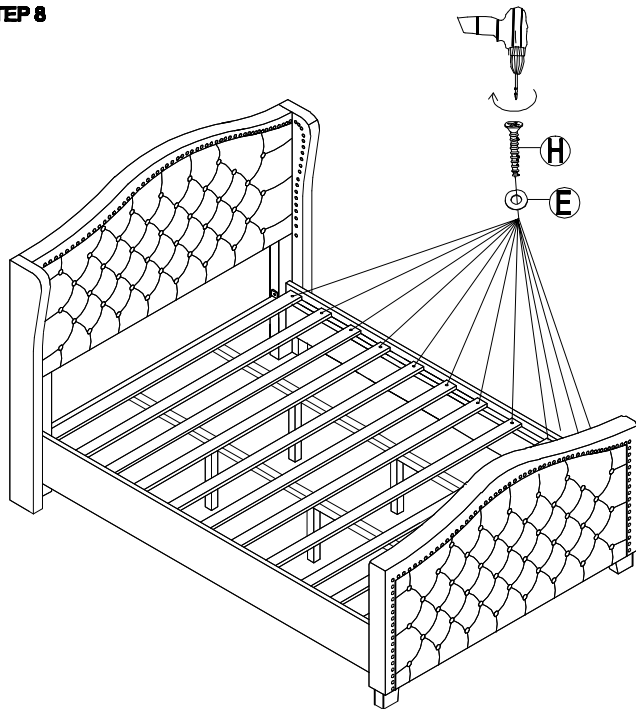
STEP 6**STEP 7****STEP 8****STEP 9**