

# Assembly Instructions

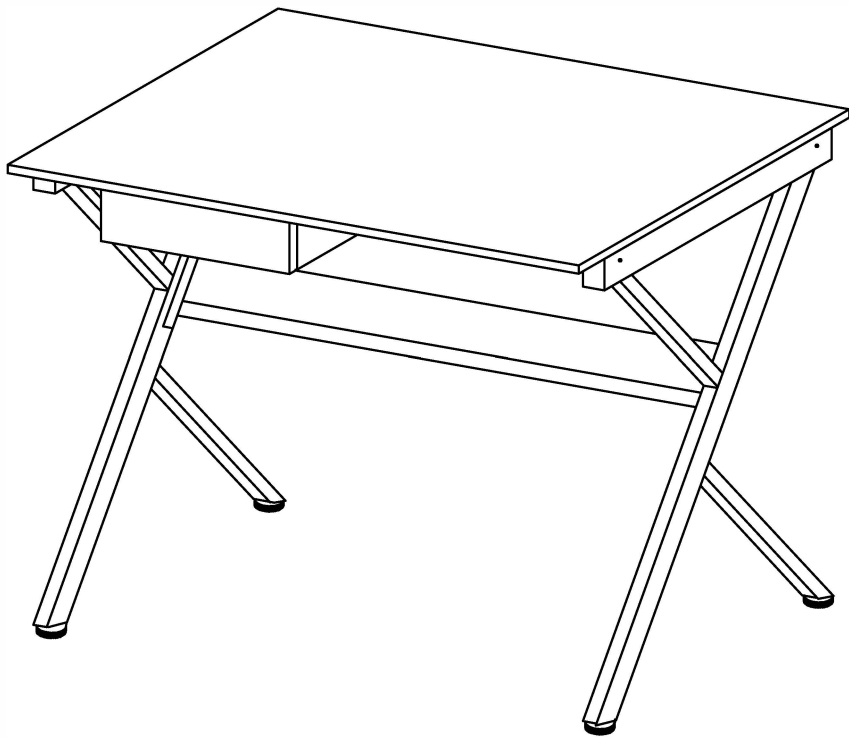

## ASSEMBLY RATING

The Assembly Rating is a 5-point system that shows the degree of effort needed in assembling a specific product (with 1 being easy and 5 being difficult). For some products, two persons are recommended.

EASY  DIFFICULT

## Tools Required For Assembly:

Allen Wrench

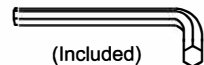

(Included)

Phillips Screwdriver



(Not Included)



2 PERSONS RECOMMENDED

# ASSEMBLY & CARE ADVICE

FOR YOUR FURNITURE TO LAST, CORRECT ASSEMBLY AND PROPER MAINTENANCE ARE NECESSARY. PLEASE FOLLOW THE INFORMATION PROVIDED BELOW TO FULLY ENJOY YOUR FURNITURE.

## BASIC ASSEMBLY TECHNIQUES



When lock or spring washer is used in an assembly, please make sure the lock or spring washer is placed between the larger flat washer and the head of the screw or bolt.



Position each part correctly and insert screws or bolts into their respective holes by hand tighten or using the proper hand tool. Only tighten when step is completed or when instructed to do so.



Use cardboard or carpet area when assembling furniture to prevent scratches. Make sure the furniture rests on a flat and level surface with each leg evenly touching the floor.



Some furniture comes with height adjustment knobs underneath each leg. To lower or to raise each leg, you need to turn clockwise or counterclockwise, respectively.



Make sure all parts are properly aligned, then use the appropriate hand tool to completely tighten the bolts or screws. Do not use power tools and do not overtighten.



Save the instructions and store the Allen wrench or any supplied tool for later maintenance. After two weeks, check and tighten any loose hardware and repeat again every six months thereafter.

IT IS THE USER'S RESPONSIBILITY TO MAINTAIN THE FURNITURE. THE HARDWARE MAY LOOSEN OVER TIME AND MAY CAUSE THE FURNITURE TO BE WOBBLY AND UNABLE TO SUPPORT ITS INTENDED WEIGHT CAPACITY. THIS MAY LEAD TO COLLAPSE AND MAY CAUSE SERIOUS INJURY.



**FAILURE TO FOLLOW THE GUIDELINES ABOVE MAY RESULT IN INJURY AND/OR PROPERTY DAMAGE.**

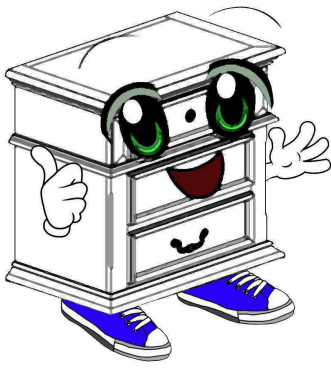

Before you begin, please read Page 2 of "Assembly and Care Advice".

And remember, do not tighten until each step is completed or instructed.

## Parts List

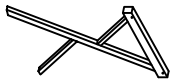

#1 x 2pcs  
Side Panel



#2 x 2pcs  
Stretcher



#3 x 1pc  
Back Panel

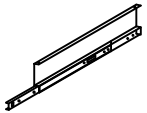

#4 x 1pc  
Drawer Panel - Left

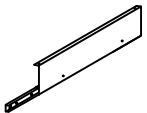

#5 x 1pc  
Drawer Panel - Right



#6 x 1pc  
Table Top



#7 x 1pc  
Drawer Front



#8 x 1pc  
Drawer Back Board



#9 x 1pc  
Drawer Front Board



#10 x 1pc  
Drawer Board - Left

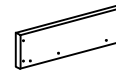

#11 x 1pc  
Drawer Board - Right

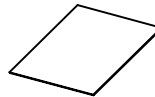

#12 x 1pc  
Drawer Bottom Board

## Hardware List



#A x 4pcs  
Leveler

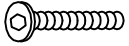

#Bx 4pcs  
Bolt 1/4" x 1-3/4"



#C x 4pcs  
Bolt 1/4"X1-1/4"



#D x 8pcs  
Bolt 1/4" x 1/2"



#Ex 2pcs  
Bolt M4 X21mm



#F x 8pcs  
Screw 25mm



#G x 6pcs  
Screw 12mm



#H x 16pcs  
Washer



#I x 1pc  
Allen Wrench



#F x 4pcs

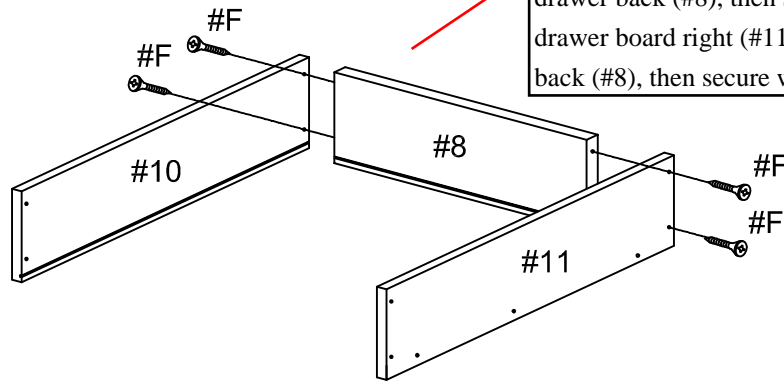

1) Align drawer board left (#10) to the left side facing drawer back (#8), then secure with screws (#F). Align drawer board right (#11) to the right side facing drawer back (#8), then secure with screws (#F).

2) Slide drawer bottom board (#12) through the thin gaps of the drawer boards.

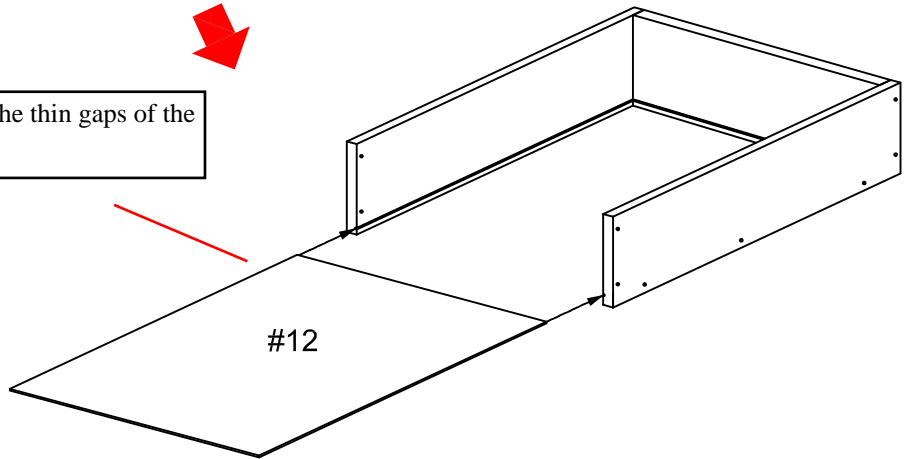

#F x 4pcs  
#E x 2pcs

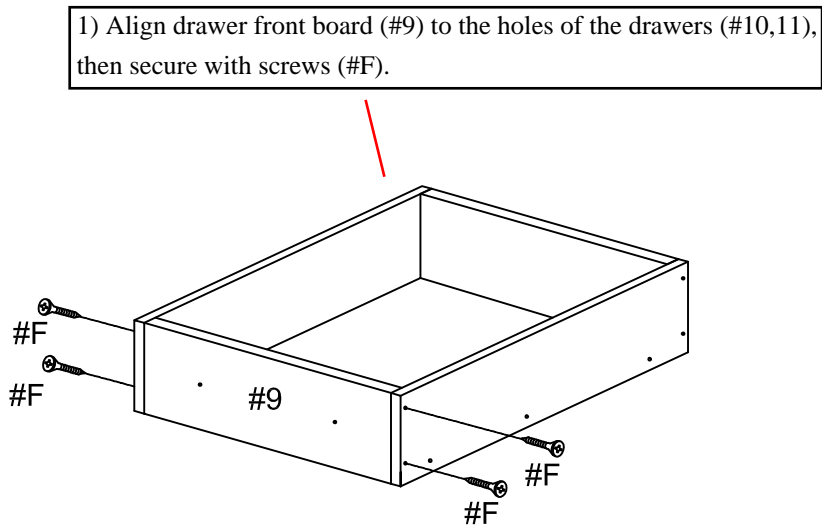

1) Align drawer front board (#9) to the holes of the drawers (#10, #11), then secure with screws (#F).

2) Align drawer front (#7) to the holes of the drawer front board (#9), then secure with bolts (#E).

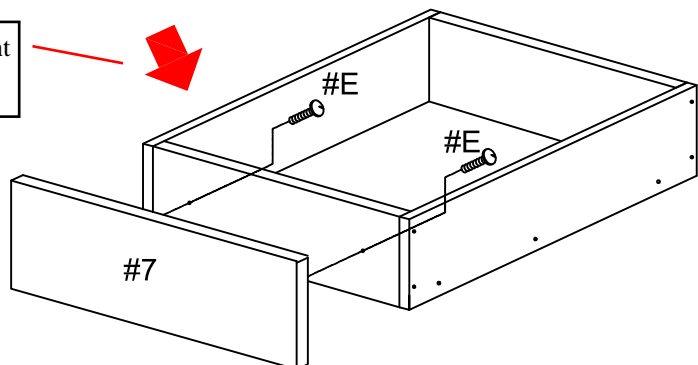



#A x 4pcs

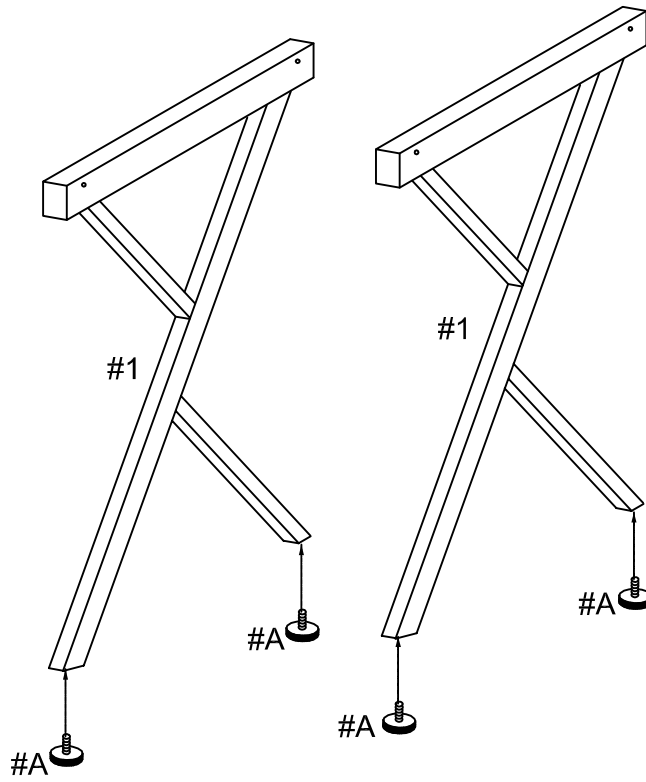

Attach adjustable floor protectors to the bottom holes of the side panels (#1). Adjust the floor protectors to ground level.



#B x 4pcs  
#H x 4pcs

Prepare 4 bolts assembly by inserting washer (#H) onto bolts (#B). Align stretchers (#2) to the holes of each side panels (#1). Secure with bolts (#B).

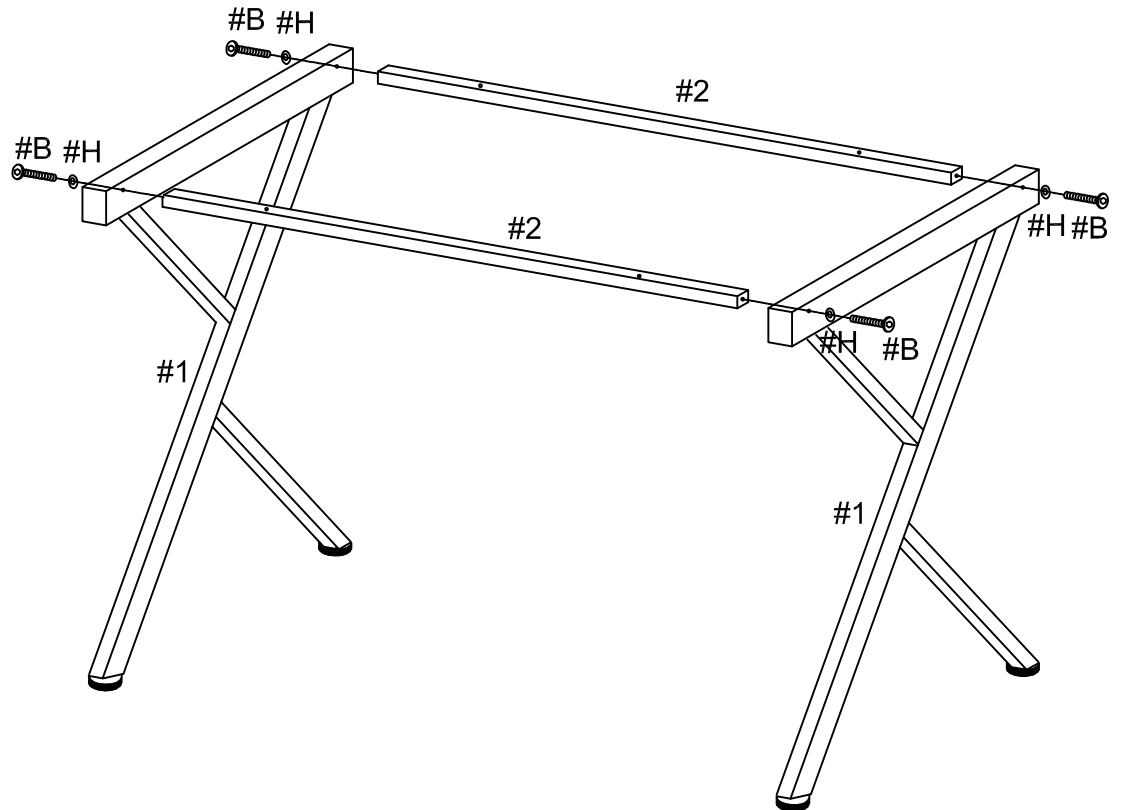



Prepare 4 bolts assembly by inserting washer (#H) onto bolts (#D). Align back panel (#3) to the holes of the side panels (#1). Secure with bolts (#D).

#D x 4pcs  
#H x 4pcs

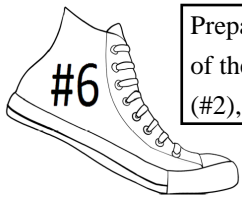
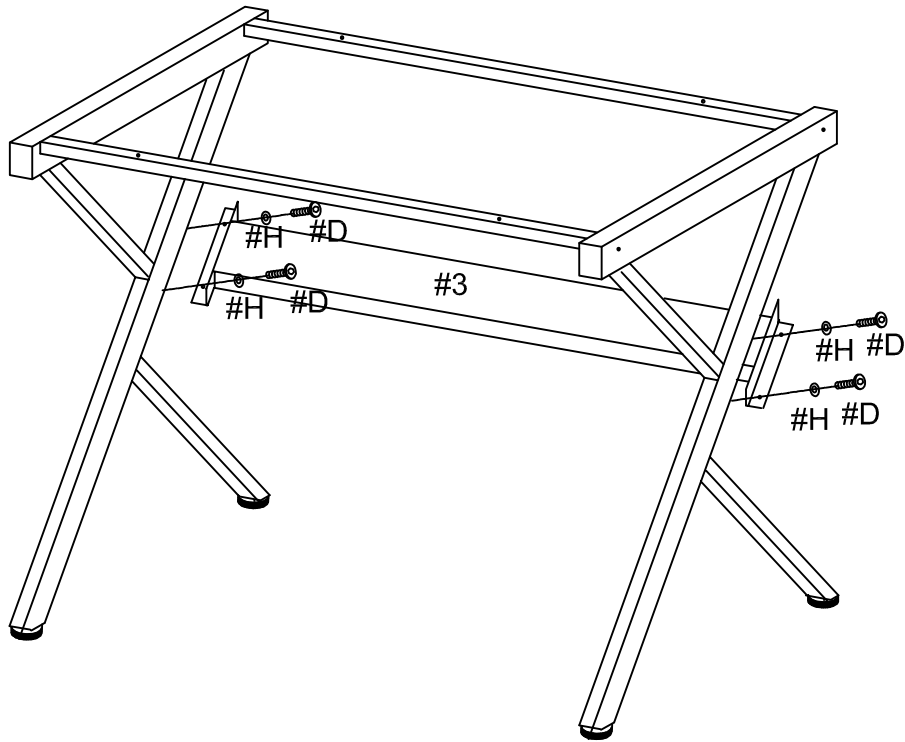

Prepare 4 bolts assembly by inserting washer (#H) onto bolts (#D). Align drawer panel left (#4) to the left side holes of the stretchers (#2), then secure with bolts (#D). Align drawer panel right (#5) to the middle holes of the stretchers (#2), then secure with bolts (#D).

#D x 4pcs  
#H x 4pcs

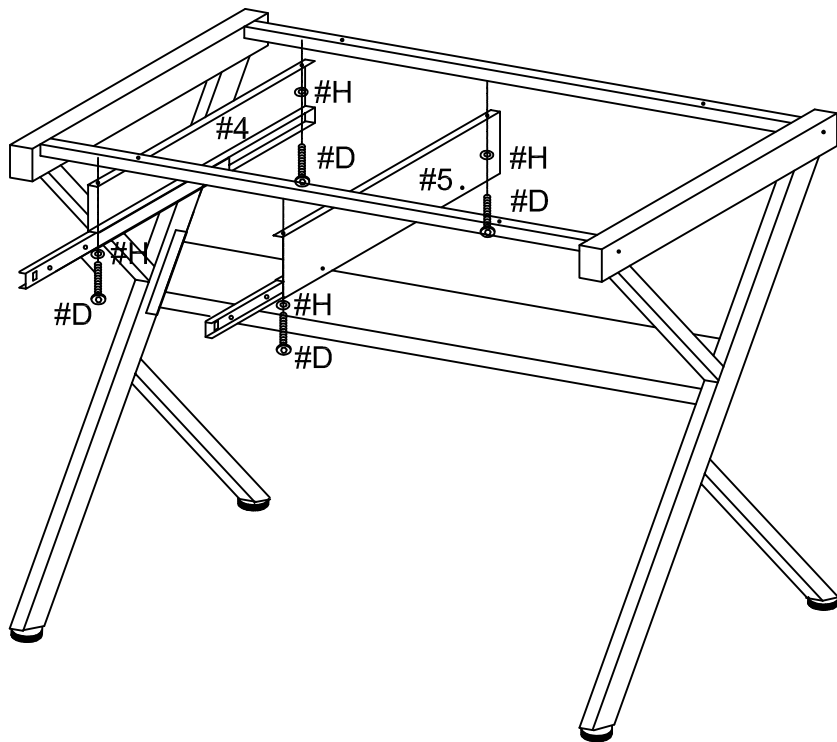



#C x 4pcs  
#H x 4pcs  
#G x 6pcs

- 1) Align drawer to the holes of the drawer rails, then secure with screws (#G).
- 2) Prepare 4 bolts assembly by inserting washer (#H) onto bolts (#C). Align table top (#6) to the holes of the desk. Secure with bolts (#C).

