

Installation & Assembly



QUESTIONS OR CONCERNS?

IMPORTANT! Please read all instructions before use and keep this manual for future reference. Your satisfaction is very important to us. If you have any issues, **PLEASE CONTACT US** before initiating a **RETURN**.

ATTENTION

Attention Customers living in the United States and Canada

If you are missing parts, hardware, or if your product has been damaged during shipping

DO NOT RETURN YOUR PRODUCT

The store does not stock parts and may not be able to help you. Please contact us directly and **we will ship you the parts** you need to your shipping address **at no cost to you**. For the quickest and most efficient service, please reach out to us.

We're here to help!

※ Stuck in Assembly Limbo? Check out our website or contact our support team for quick solutions!

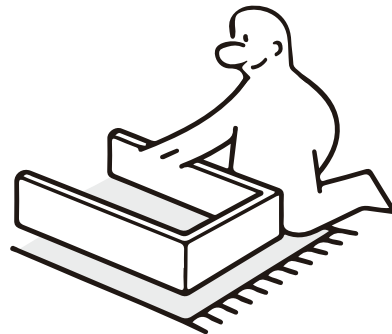
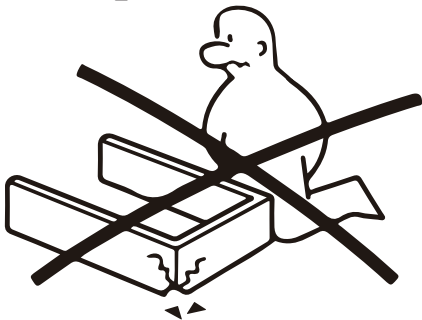

※ Stay Scratch-Free: Safeguard Your Furniture by Assembling on Carpet.

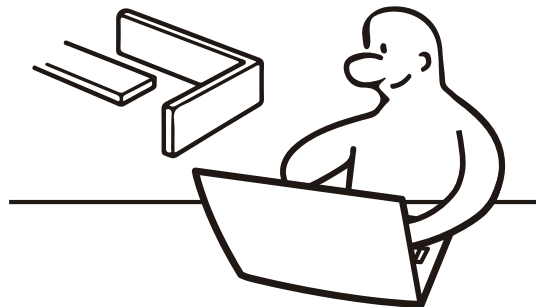
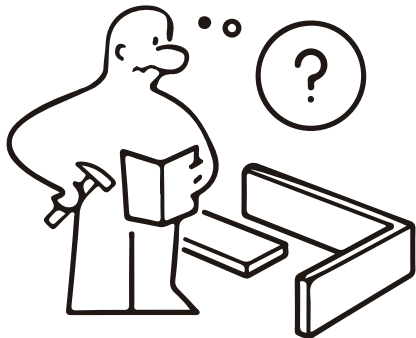

WARNING: ASSEMBLY NOTICE

Attention

Important Instructions for Assembling Your Furniture To ensure the longevity and integrity of your MDF furniture, please adhere to the following guidelines:

DO NOT USE AN ELECTRIC DRILL

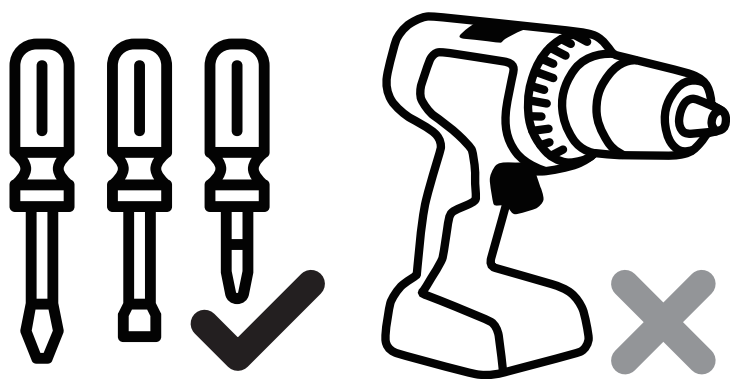

Using an electric drill can cause irreversible **damage to the MDF boards**, leading to compromised structural integrity and potential voiding of your warranty.

IF AN ELECTRIC DRILL MUST BE USED

- **Set to Lowest Torque Setting :**

Ensure your drill is set to the lowest possible torque setting to avoid over-tightening and damaging the material.

- **Proceed with Caution :**

Carefully monitor the drilling process to prevent excessive force and damage.

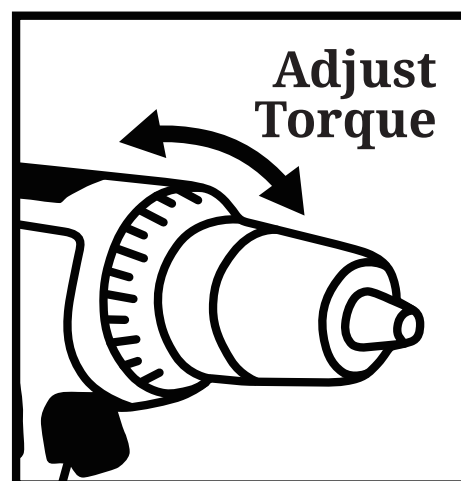

For best results and to avoid any damage, we highly recommend using the provided manual tools or a handheld screwdriver.

Thank you for your attention and understanding.

PARTS

LIST

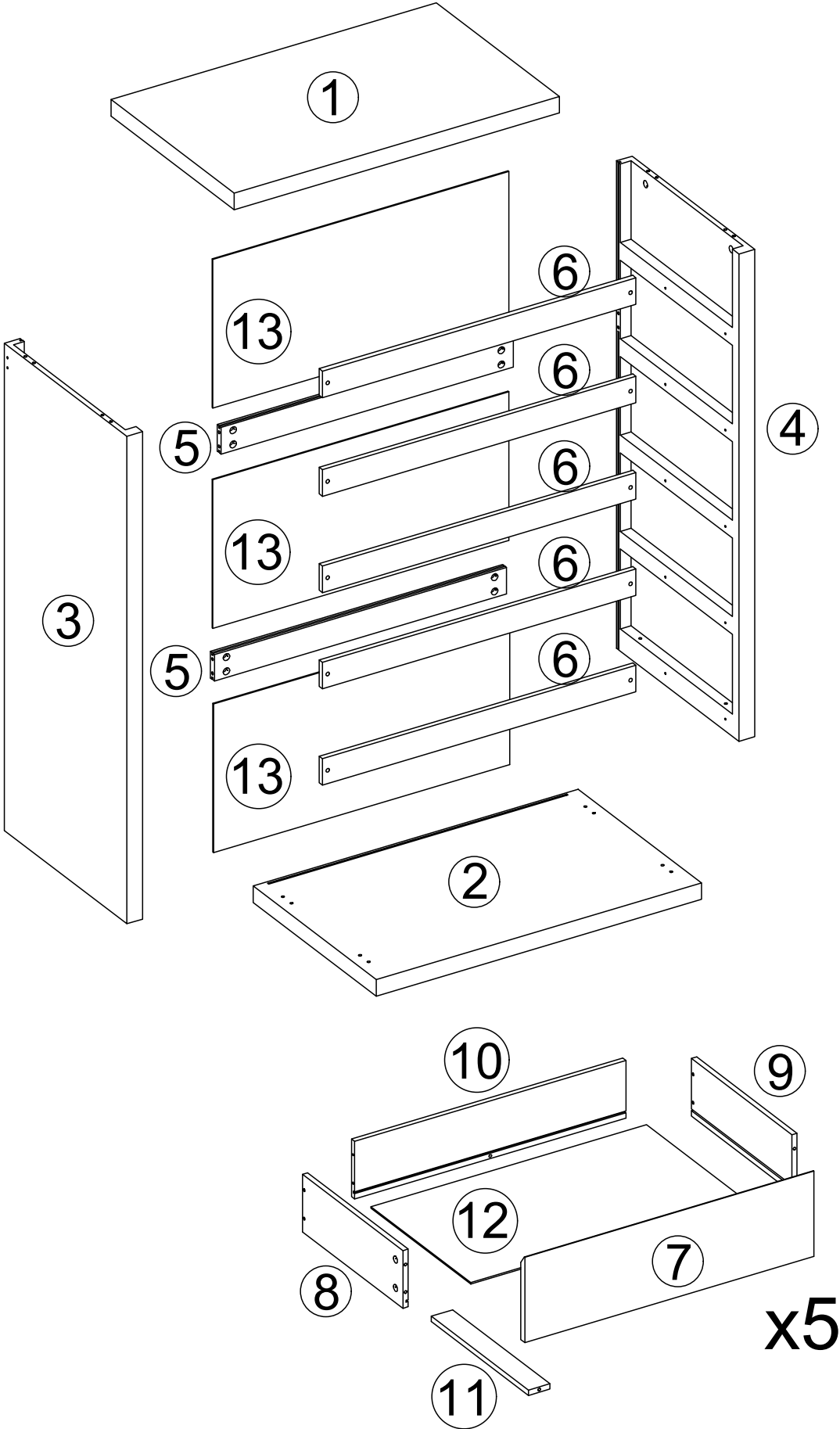





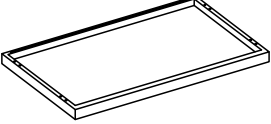
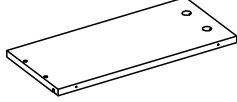
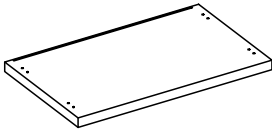
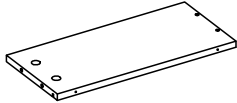
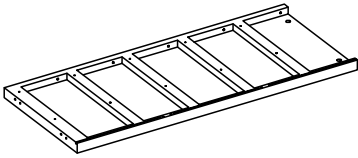
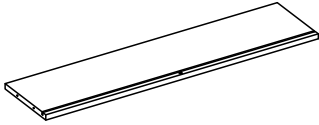
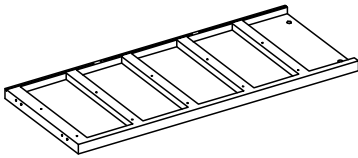
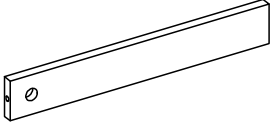
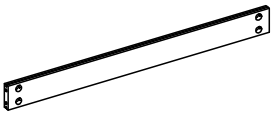
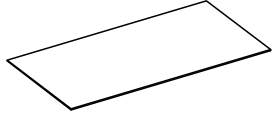
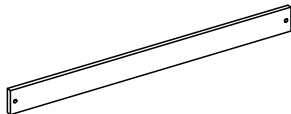
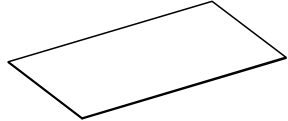
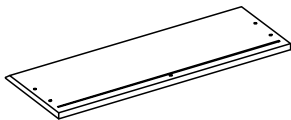



PARTS

LIST

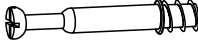
Item no.	Reference Image	Qty	Item no.	Reference Image	Qty
1		x1	8		x5
2		x1	9		x5
3		x1	10		x5
4		x1	11		x5
5		x2	12		x5
6		x5	13		x3
7		x5			

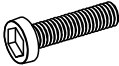
HARDWARE

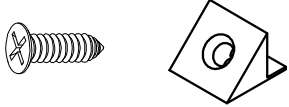
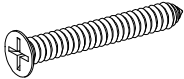
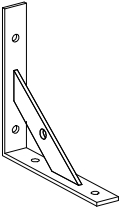
LIST

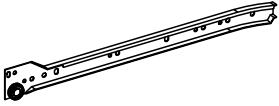
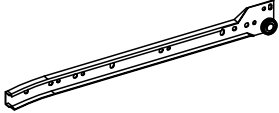
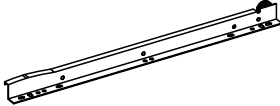
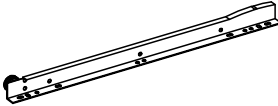
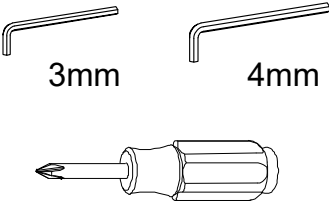
<p>A</p>  <p>x25</p>	<p>B</p>  <p>x8</p>	<p>C</p>  <p>x37</p>	<p>D</p>  <p>x37</p>
<p>E</p>  <p>φ3*12 x40</p>	<p>F</p>  <p>M6*20 x10</p>	<p>G</p>  <p>M6*60 x4</p>	<p>H</p>  <p>φ3*14 x12</p>
<p>I</p>  <p>x4</p>	<p>J</p>  <p>x2</p>	<p>K</p>  <p>K1 K2 K3 K4</p> <p>x2</p>	
<p>CL</p>  <p>x5</p>	<p>CR</p>  <p>x5</p>	<p>DL</p>  <p>x5</p>	<p>DR</p>  <p>x5</p>
 <p>3mm 4mm</p>			

1

3

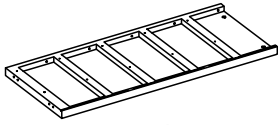

x1

4

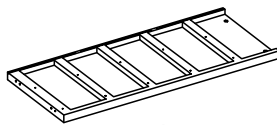

x1

C



x8

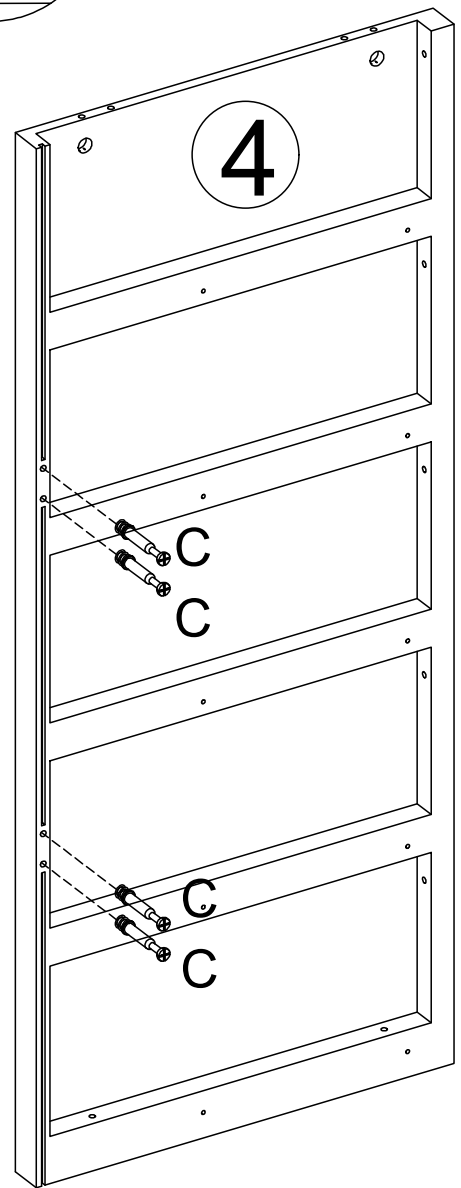
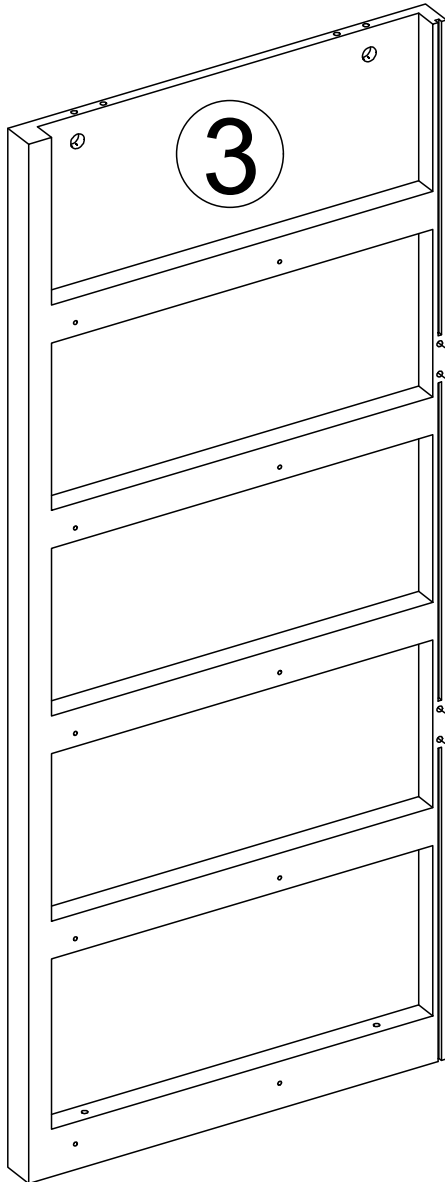
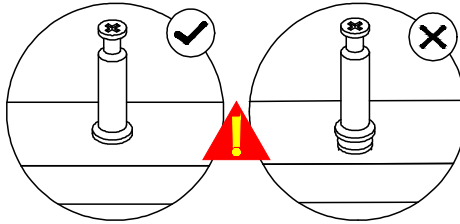

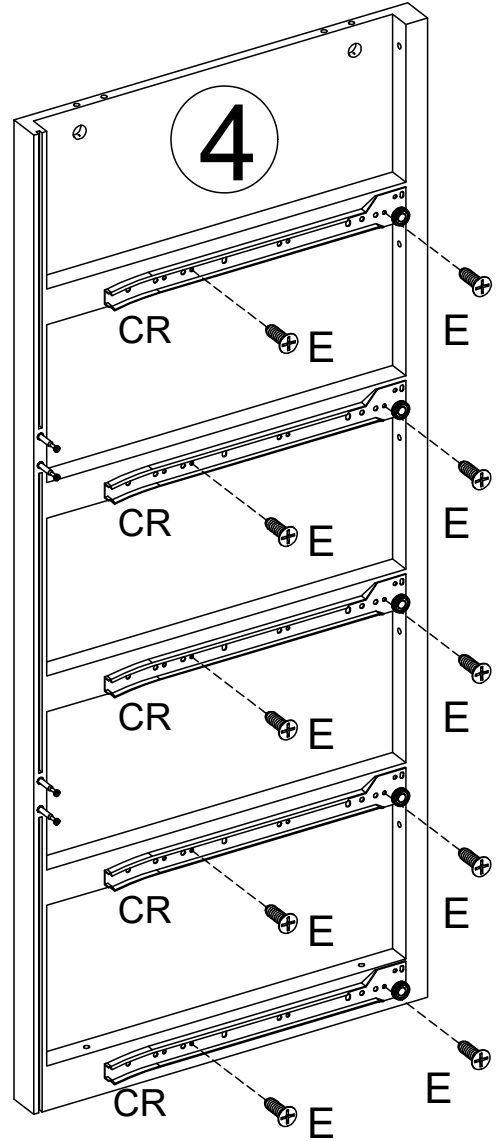
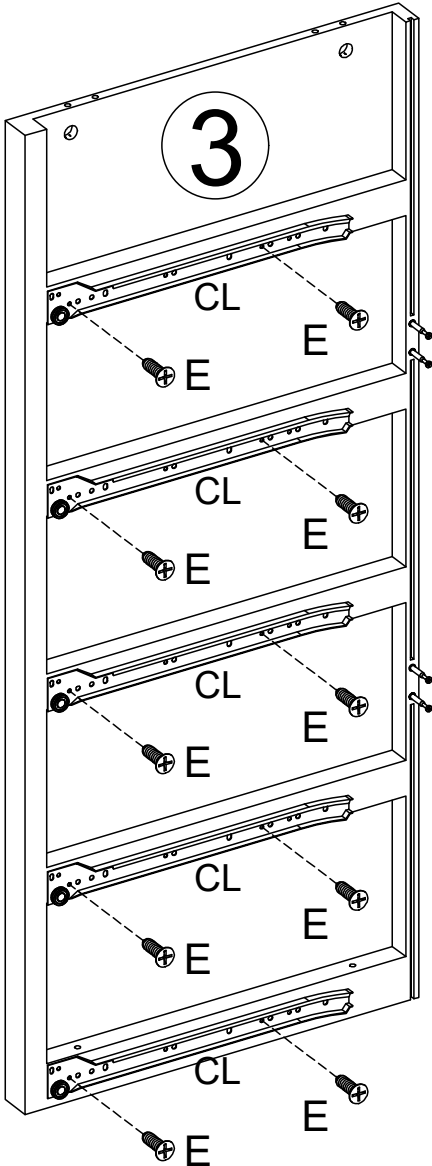
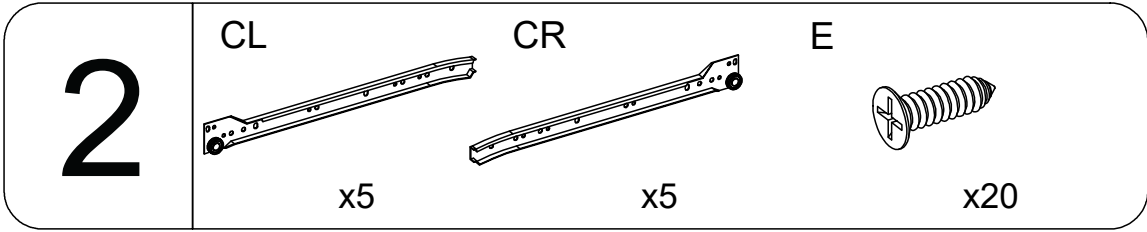

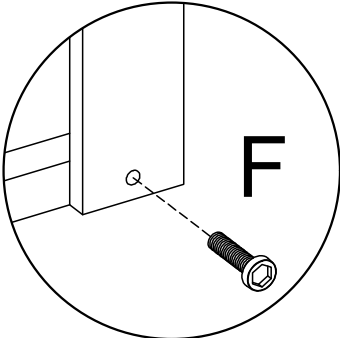
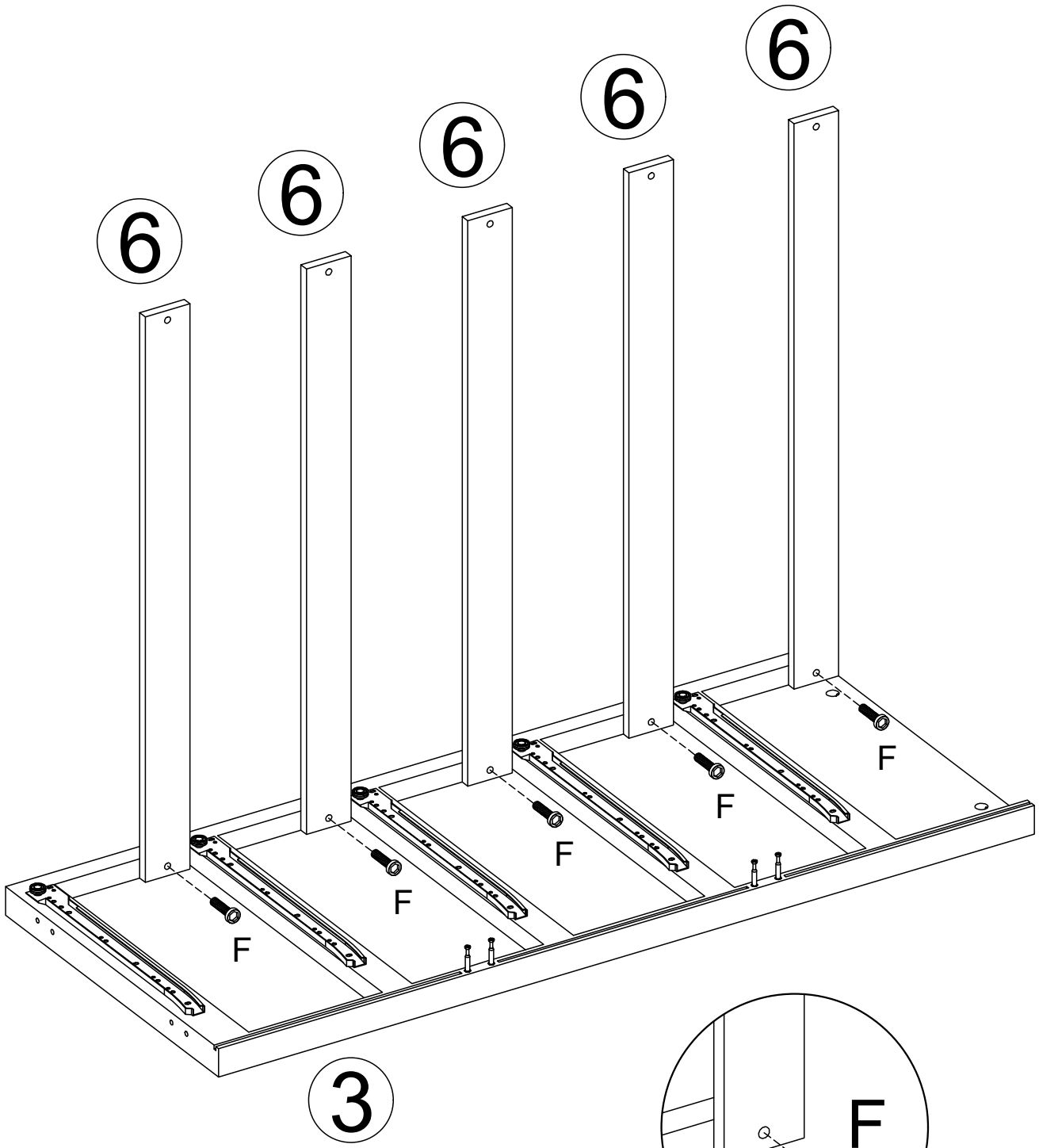
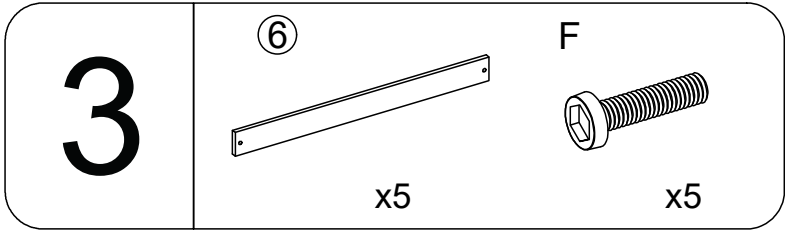

4

⑤

D

x2

x4

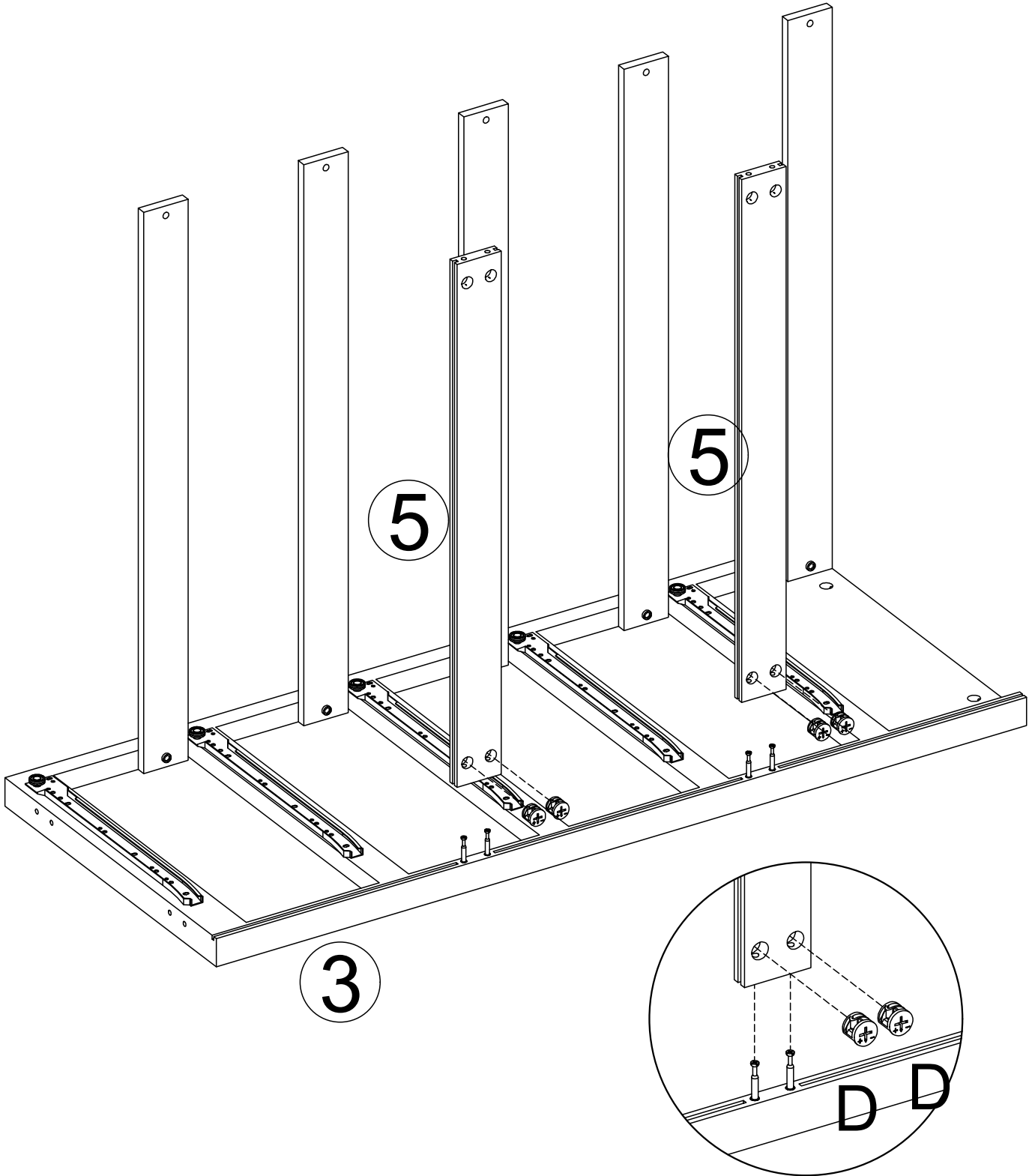
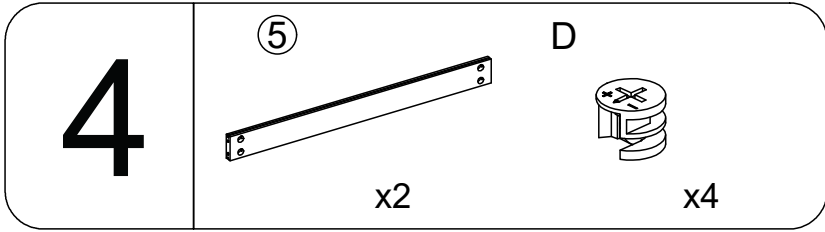

5

13

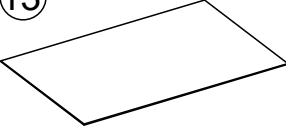

x1

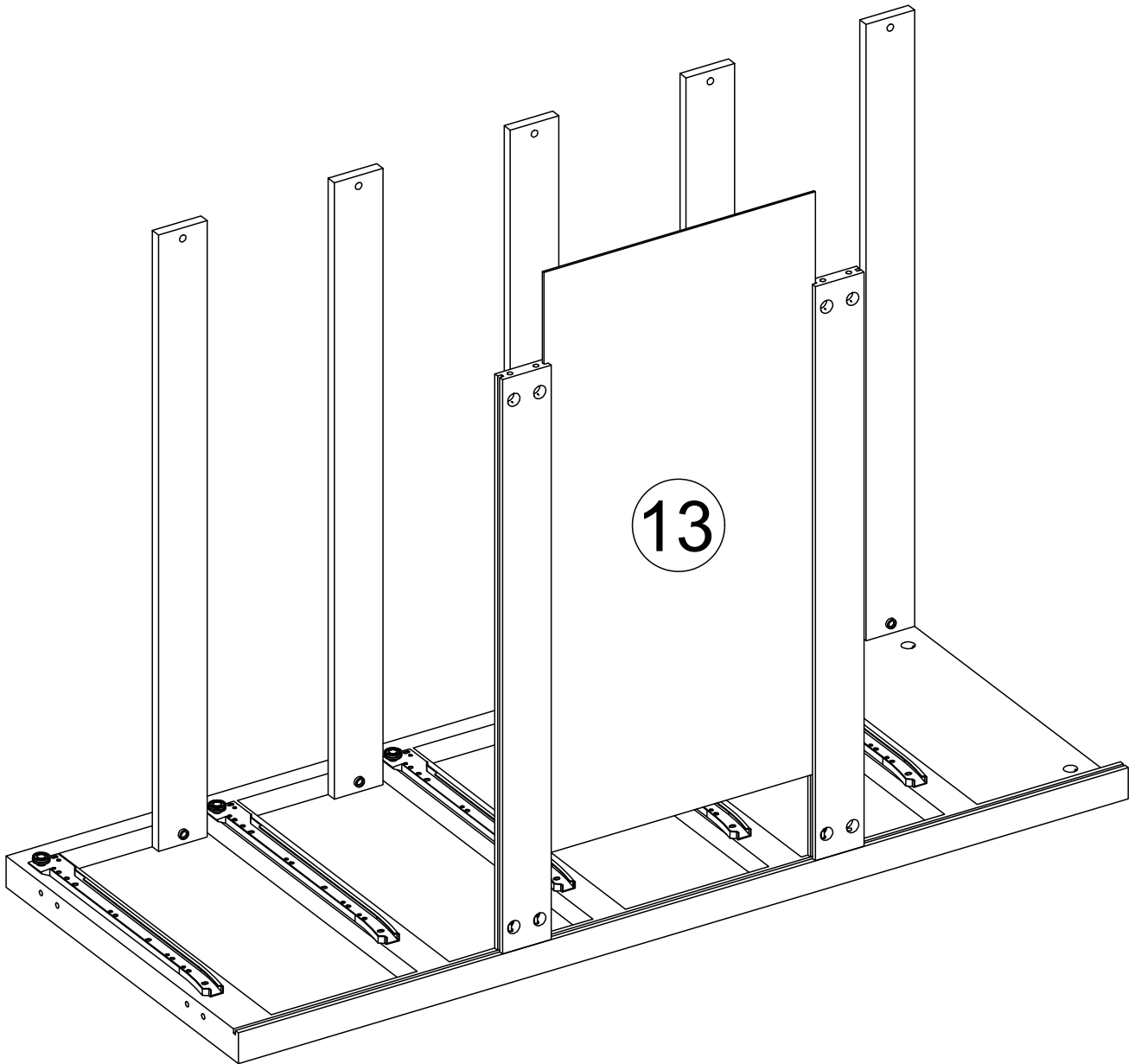

6

F D



x5 x4

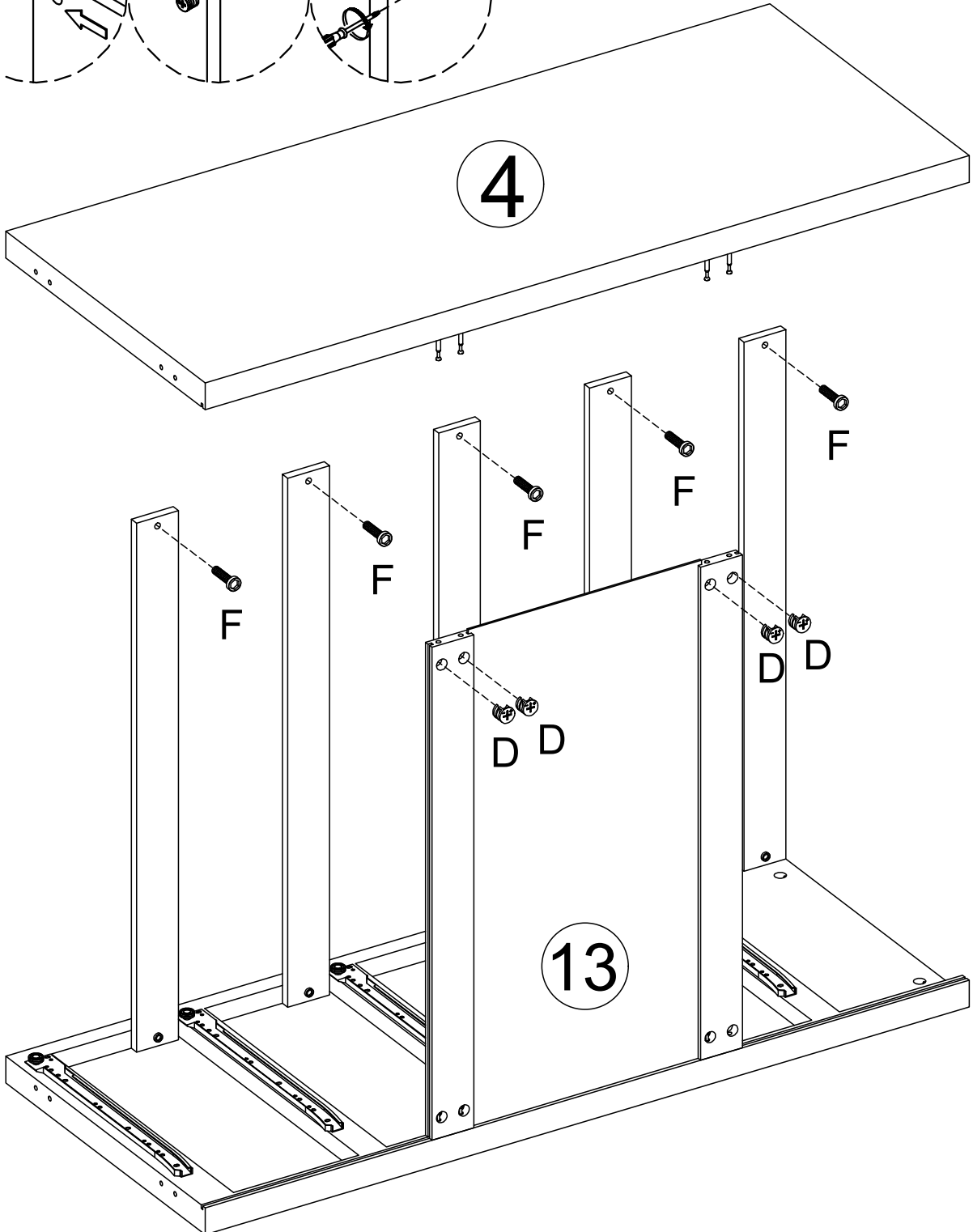
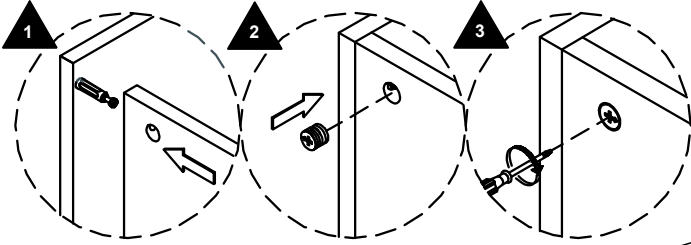

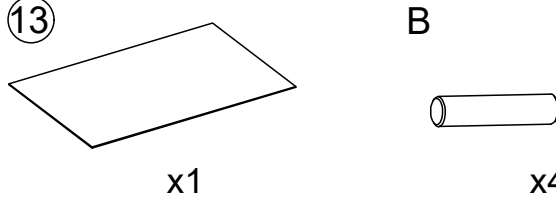

7 **13** **B**

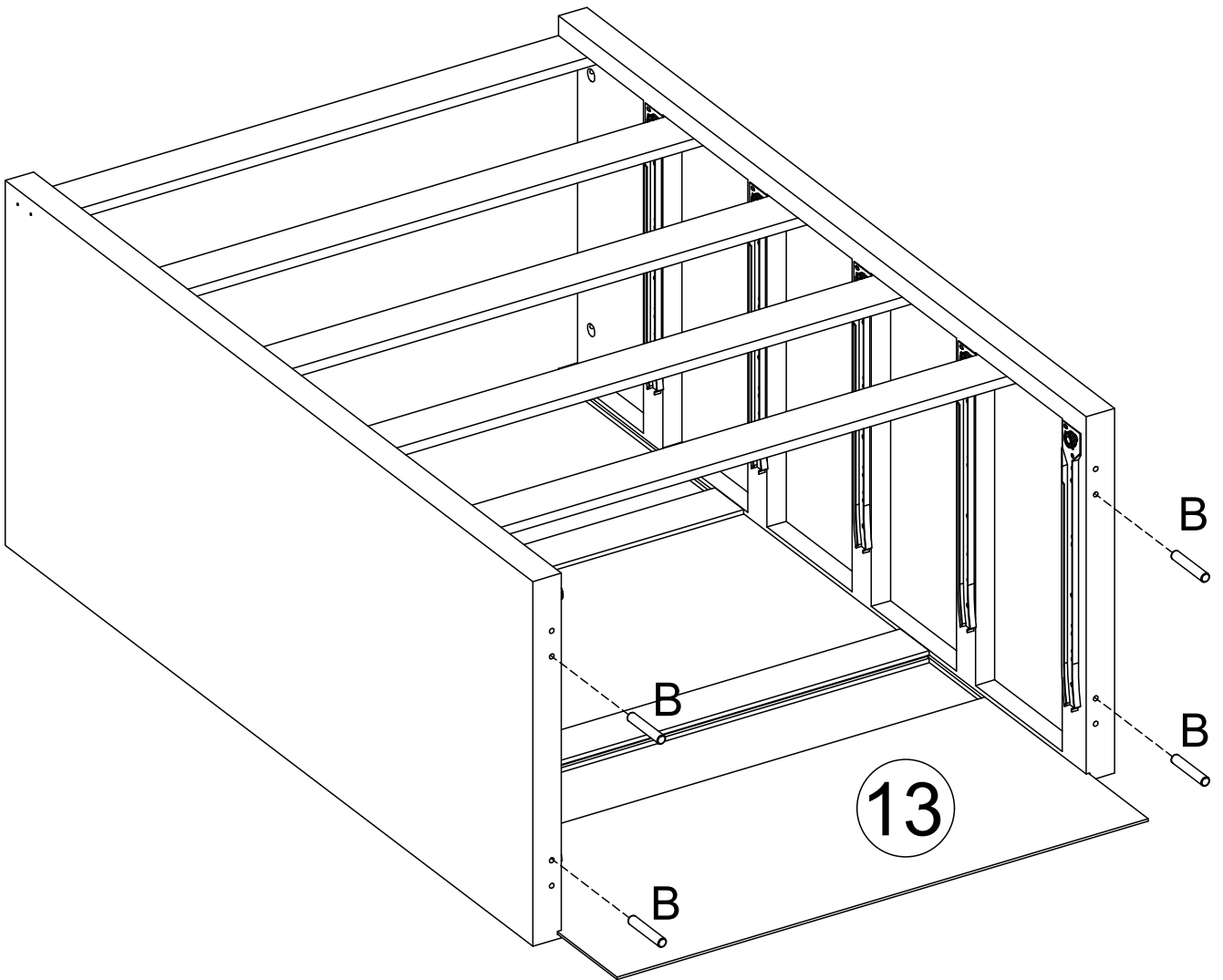

x1 x4

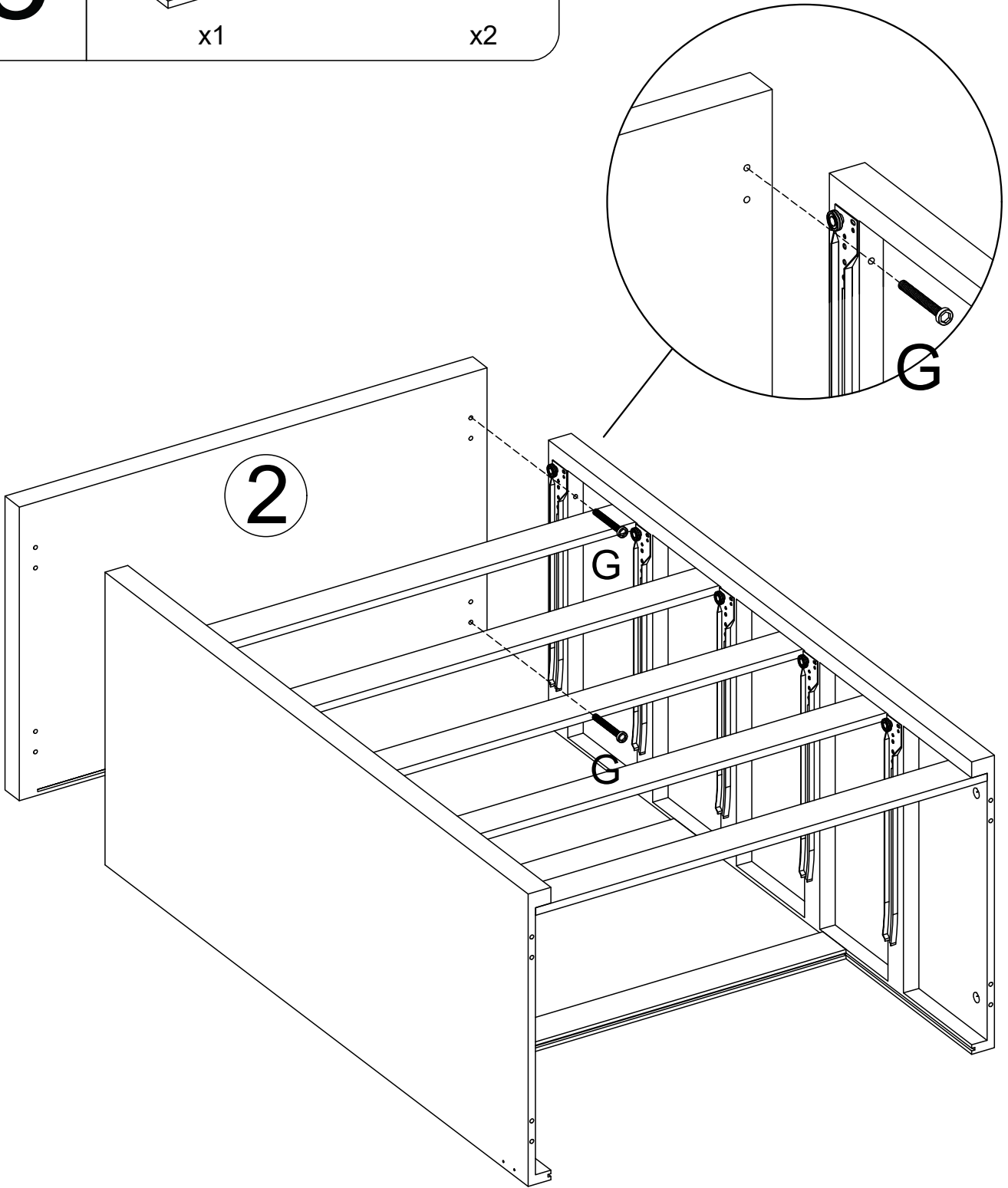
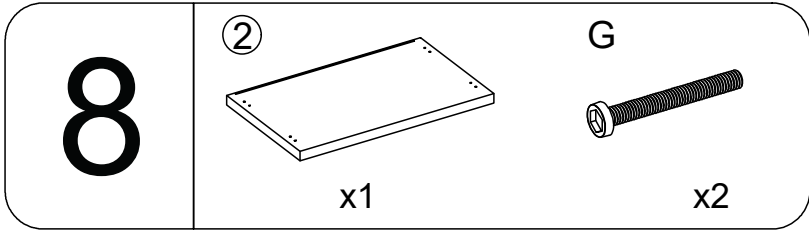



<h1>9</h1>	<p>G</p>  <p>x2</p>
------------	--

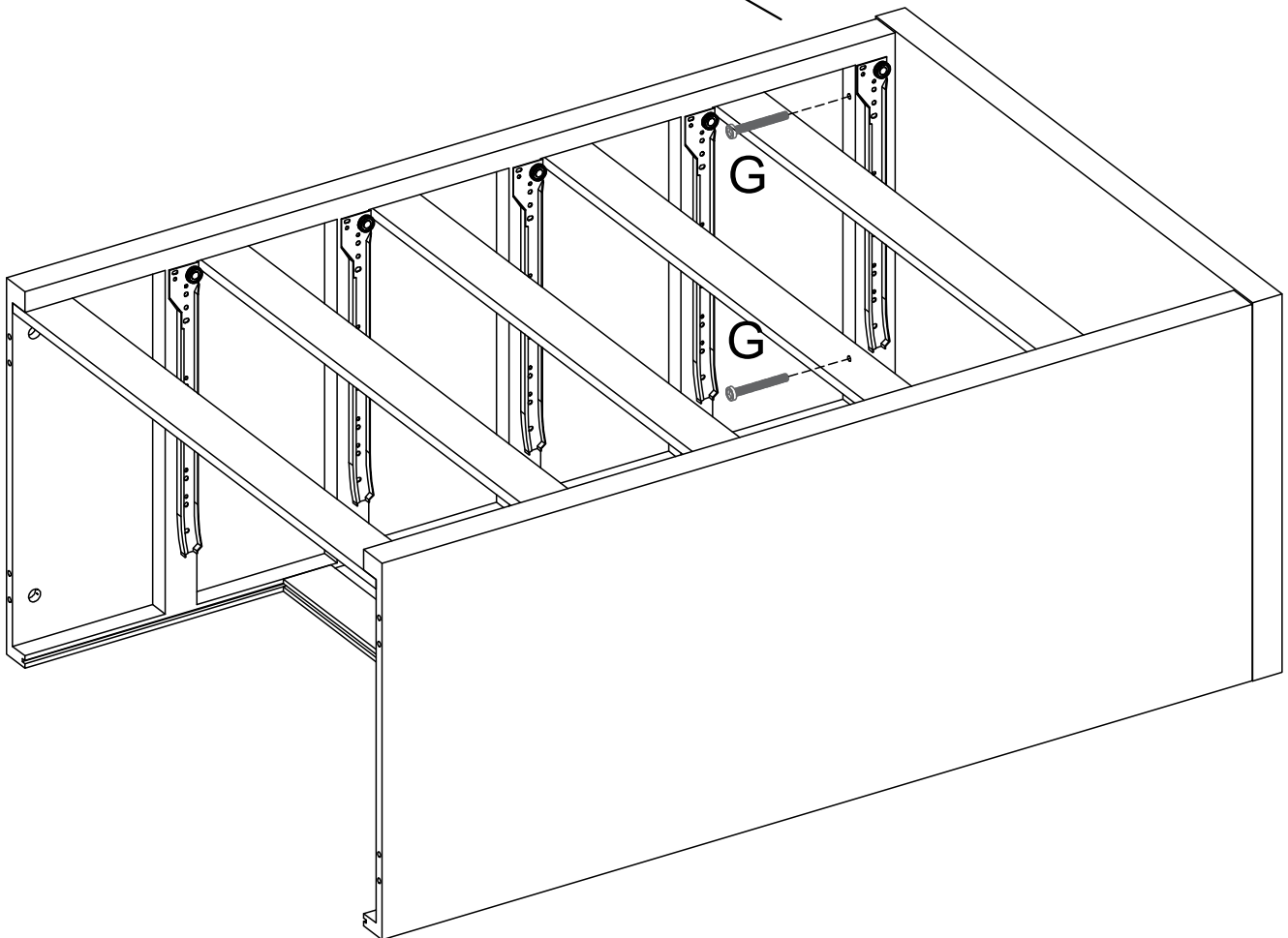
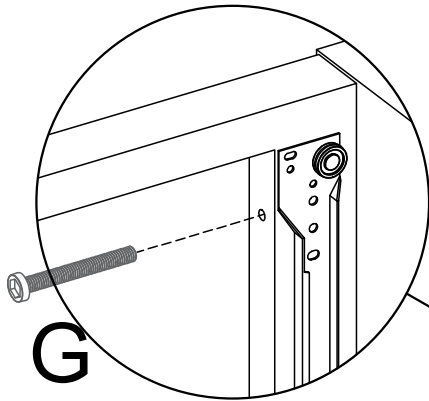

10

13

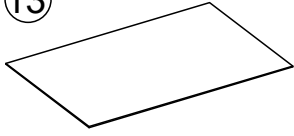

x1

B

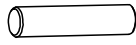

x4

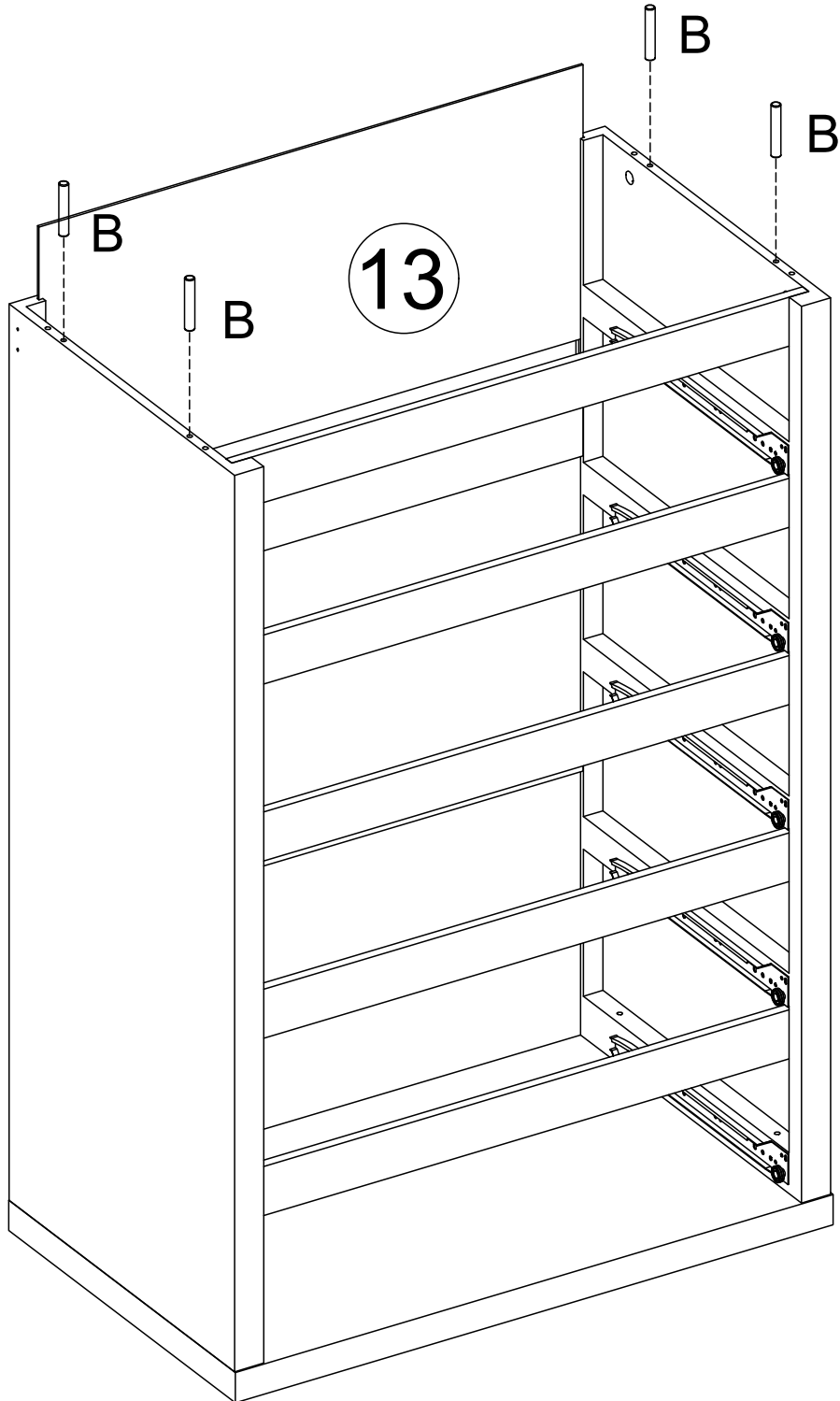

11

①

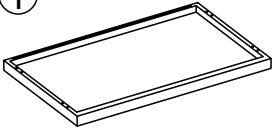

x1

C



x4

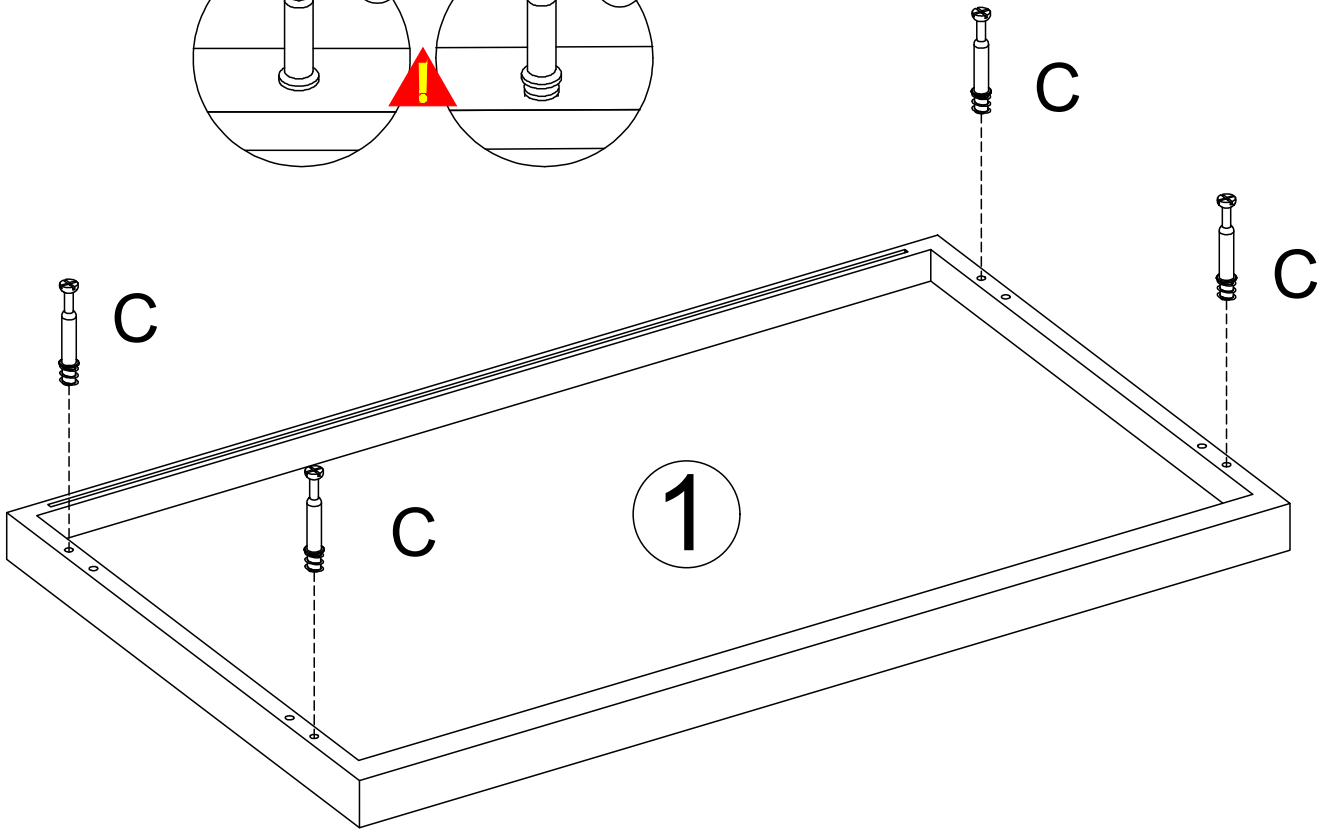
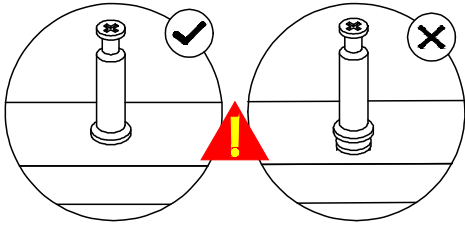

12

D



x4

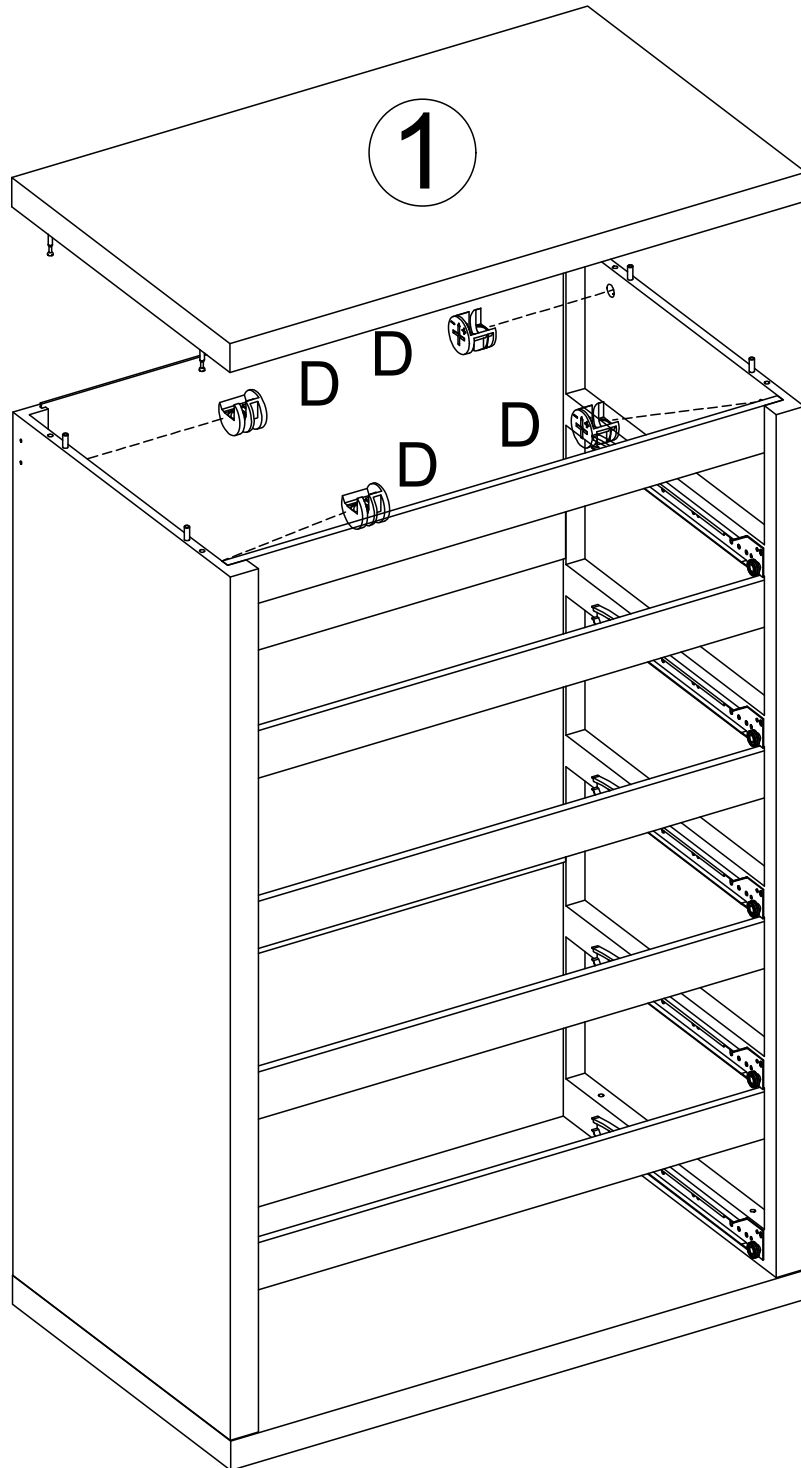
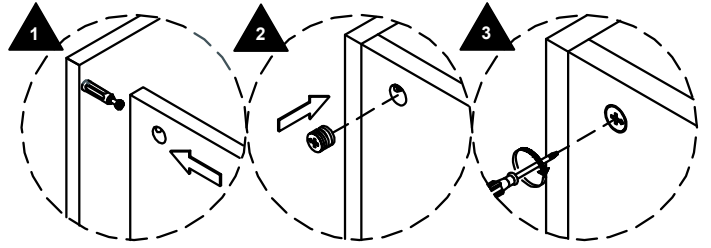

13

8

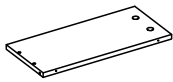

x5

9

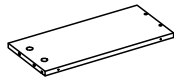

x5

10



x5

11



x5

A



x25

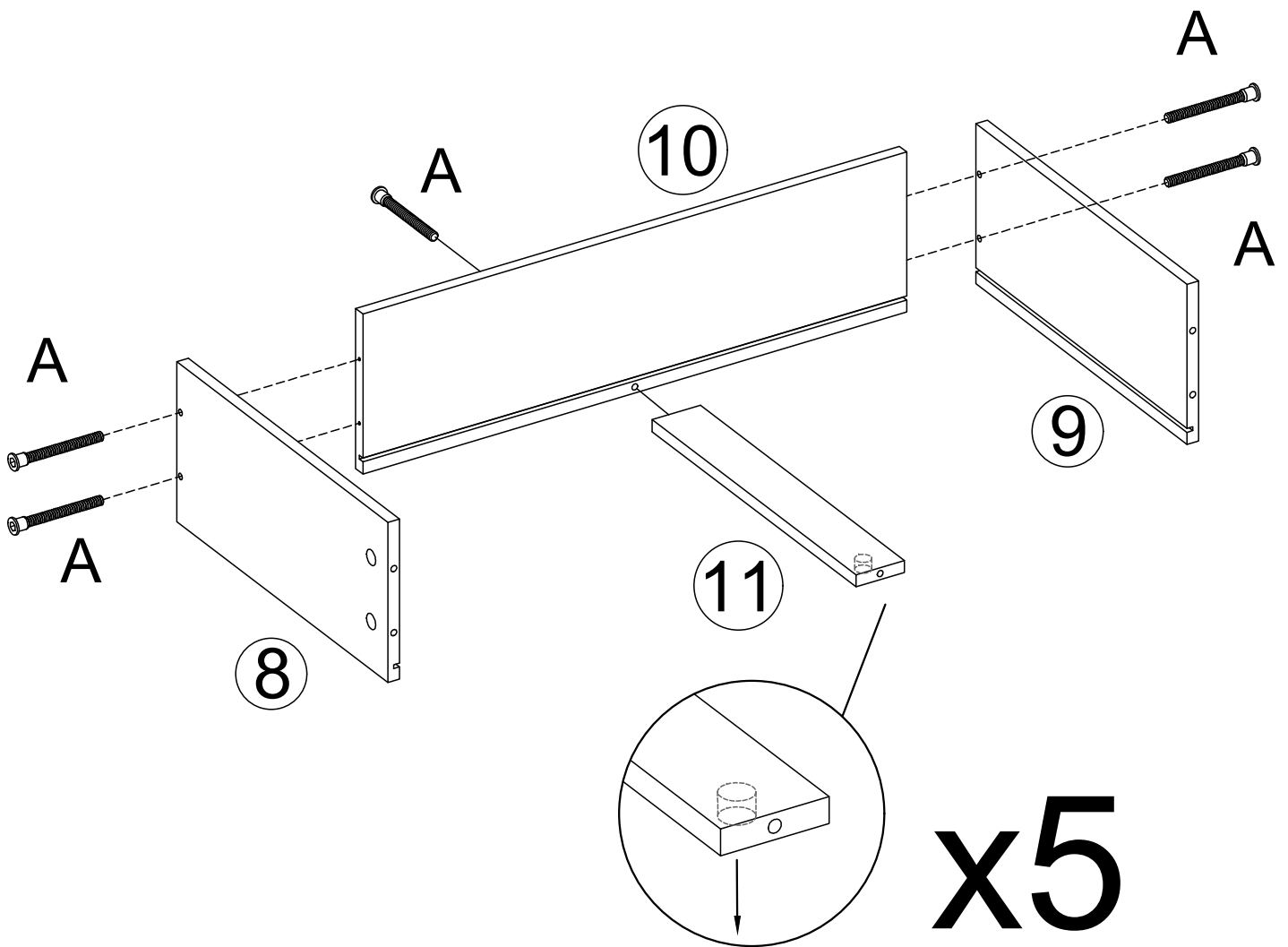

14

7



x5

12

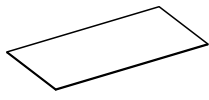

x5

C



x25

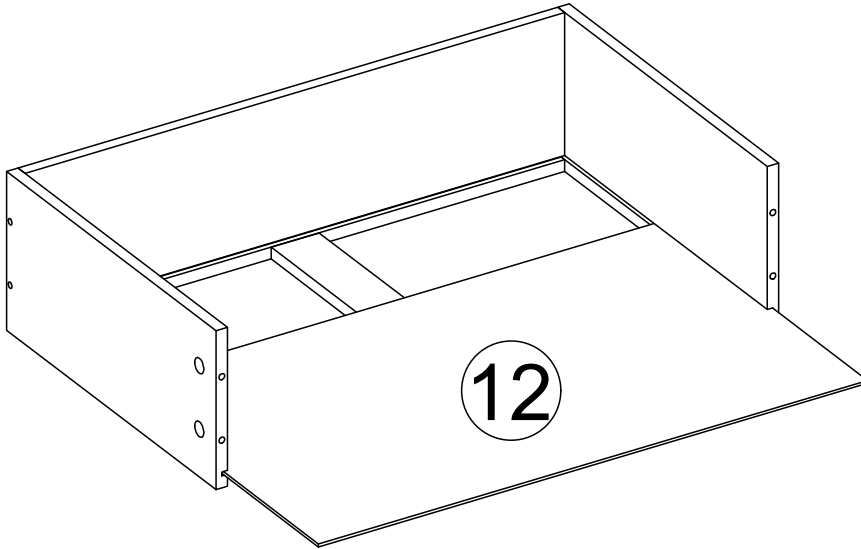

x5

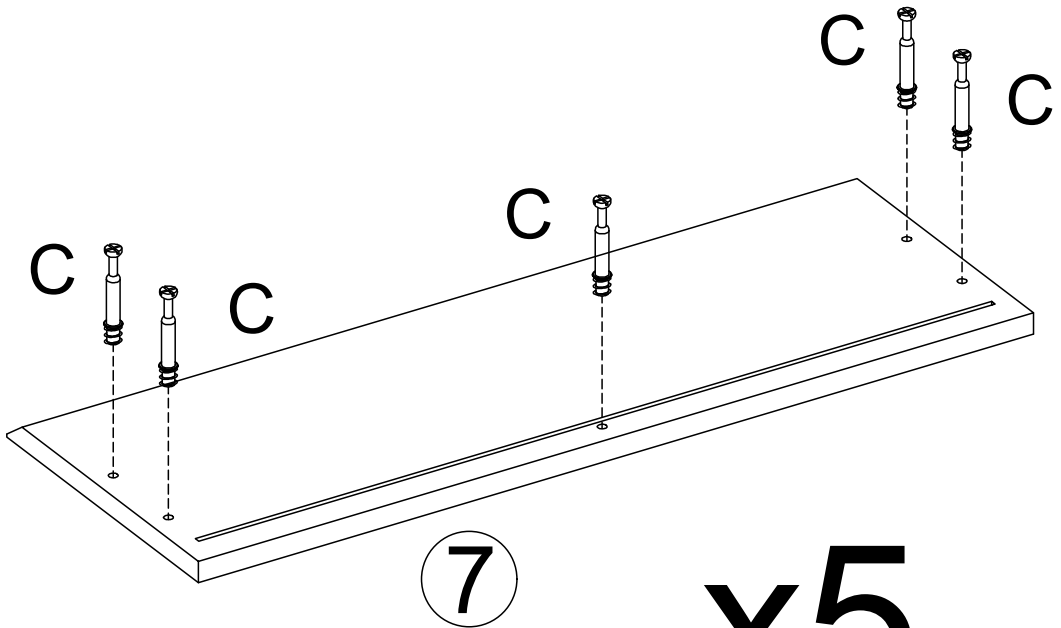

x5

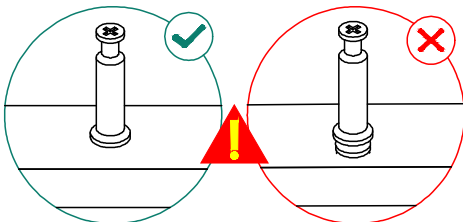

15 ^D  x20

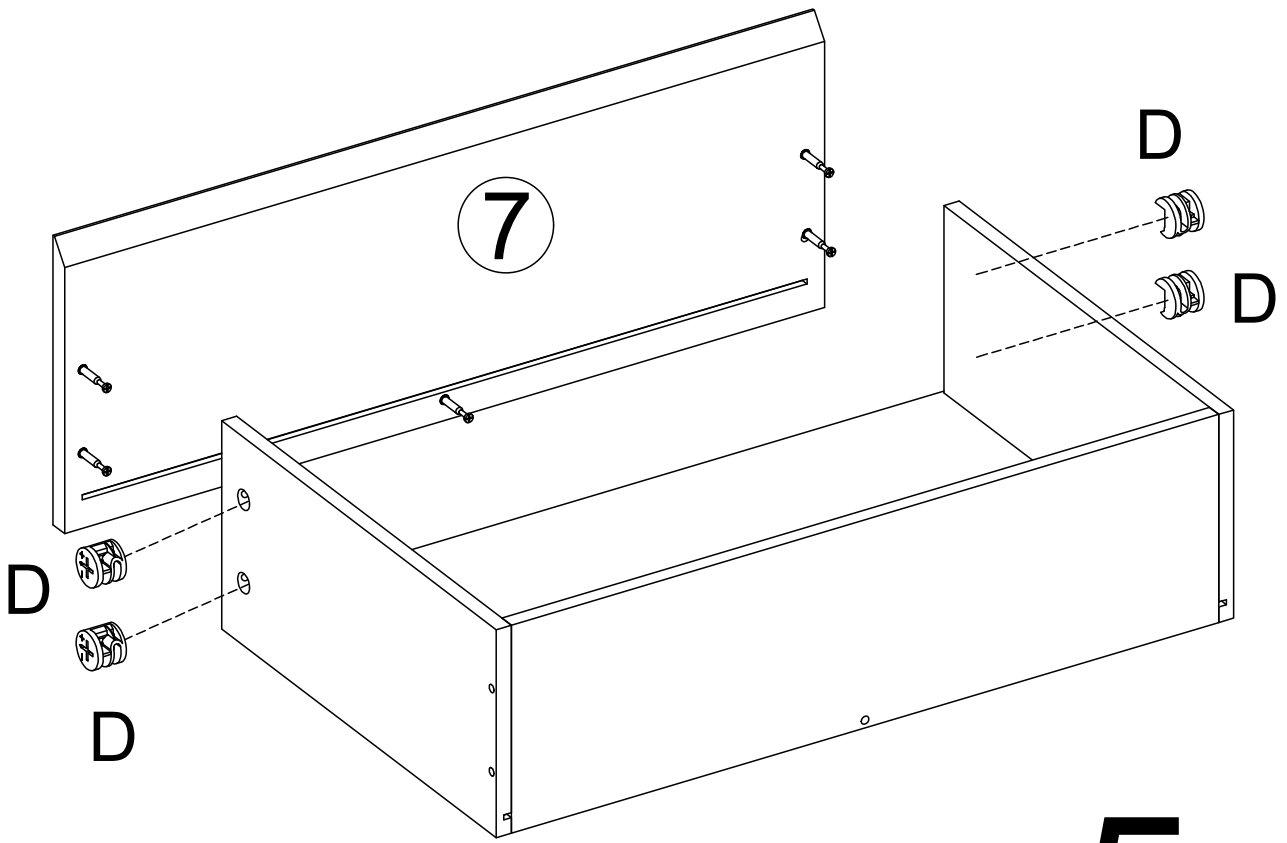

x5

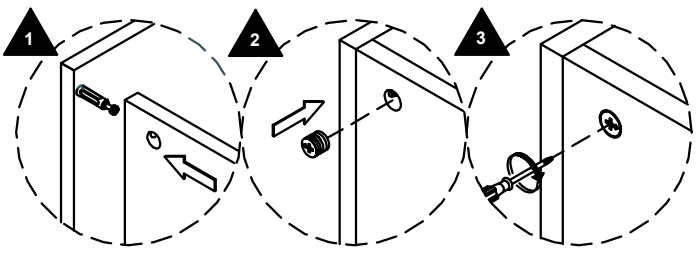

16

DL

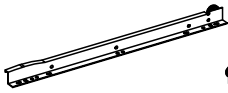

x5

DR

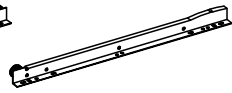

x5

E

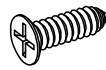

x20

D



x5

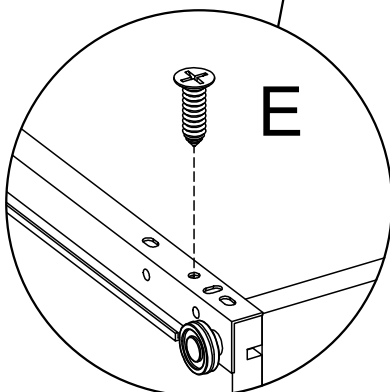
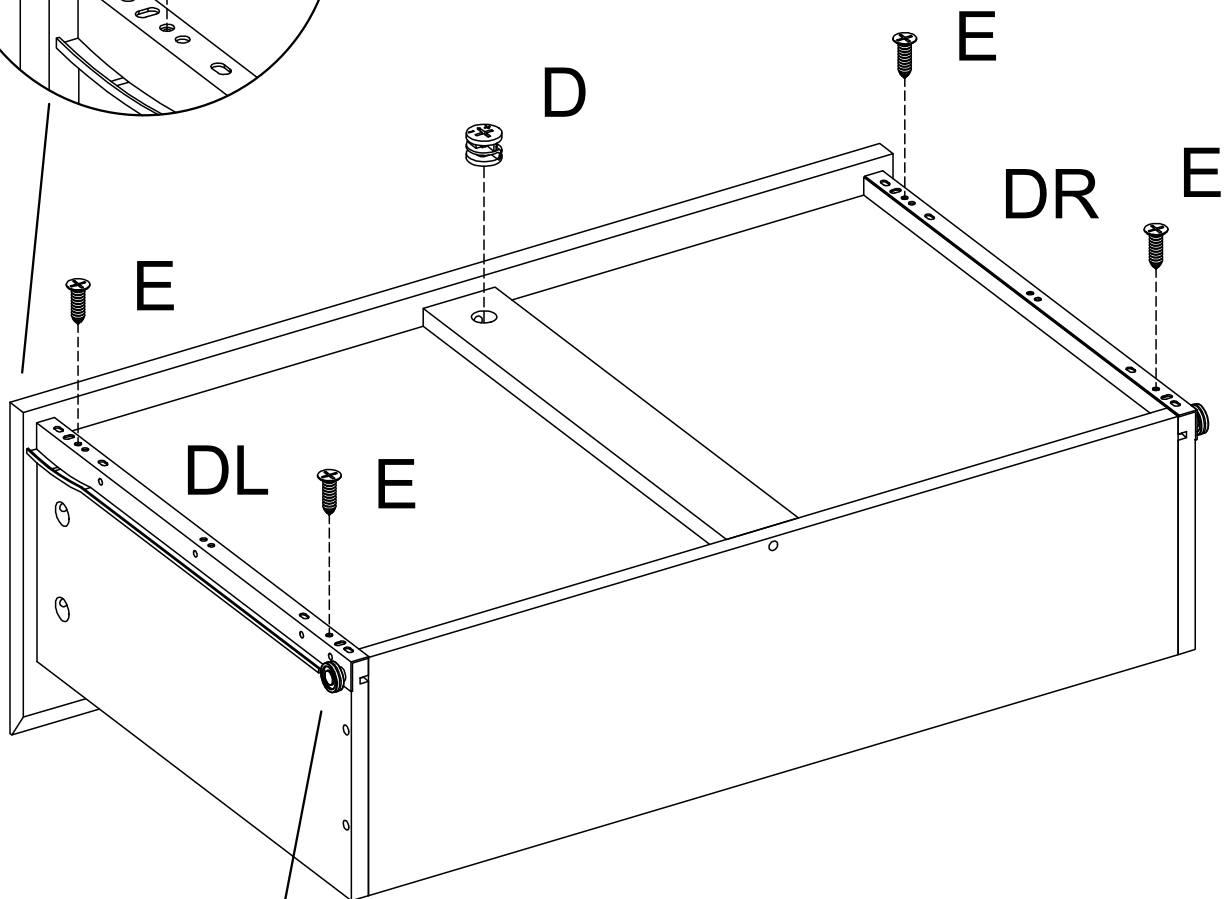
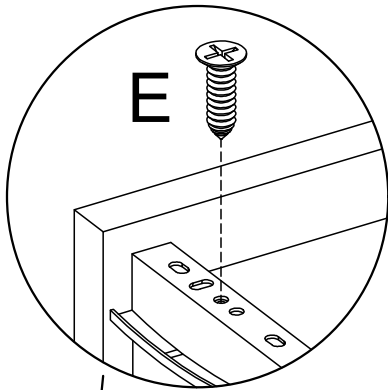

x5

17

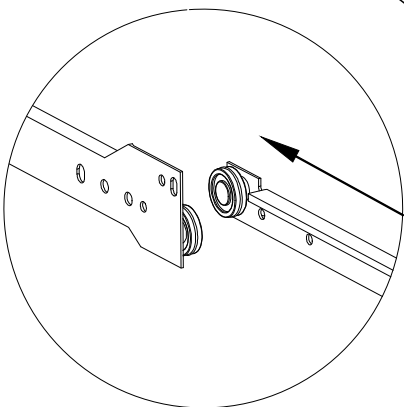
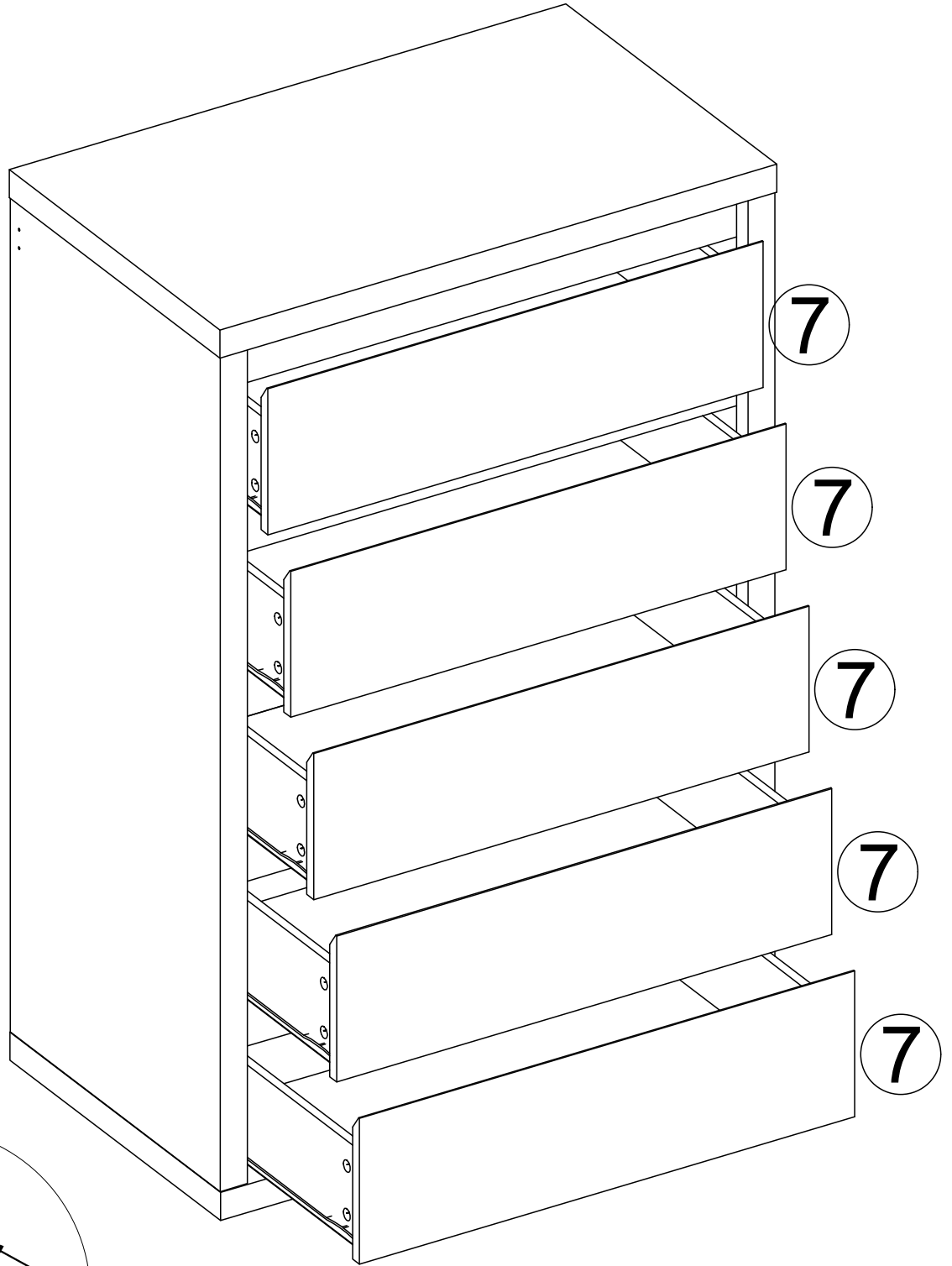

18

H

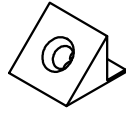
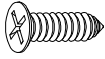

x12

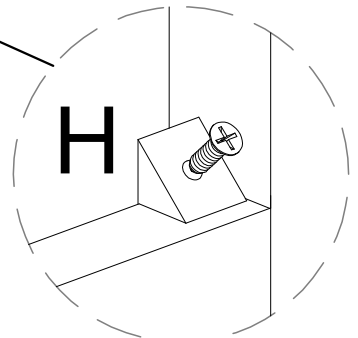
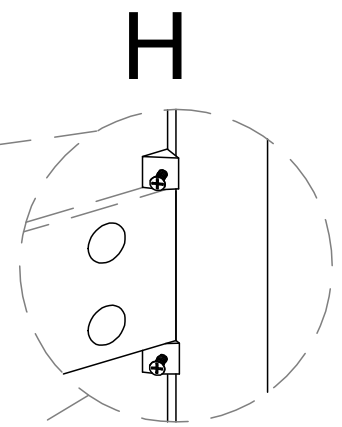
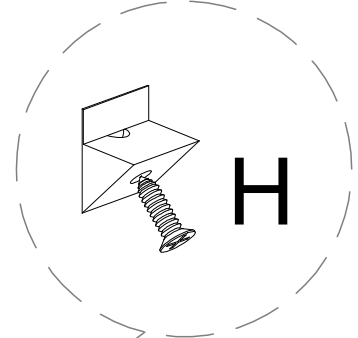
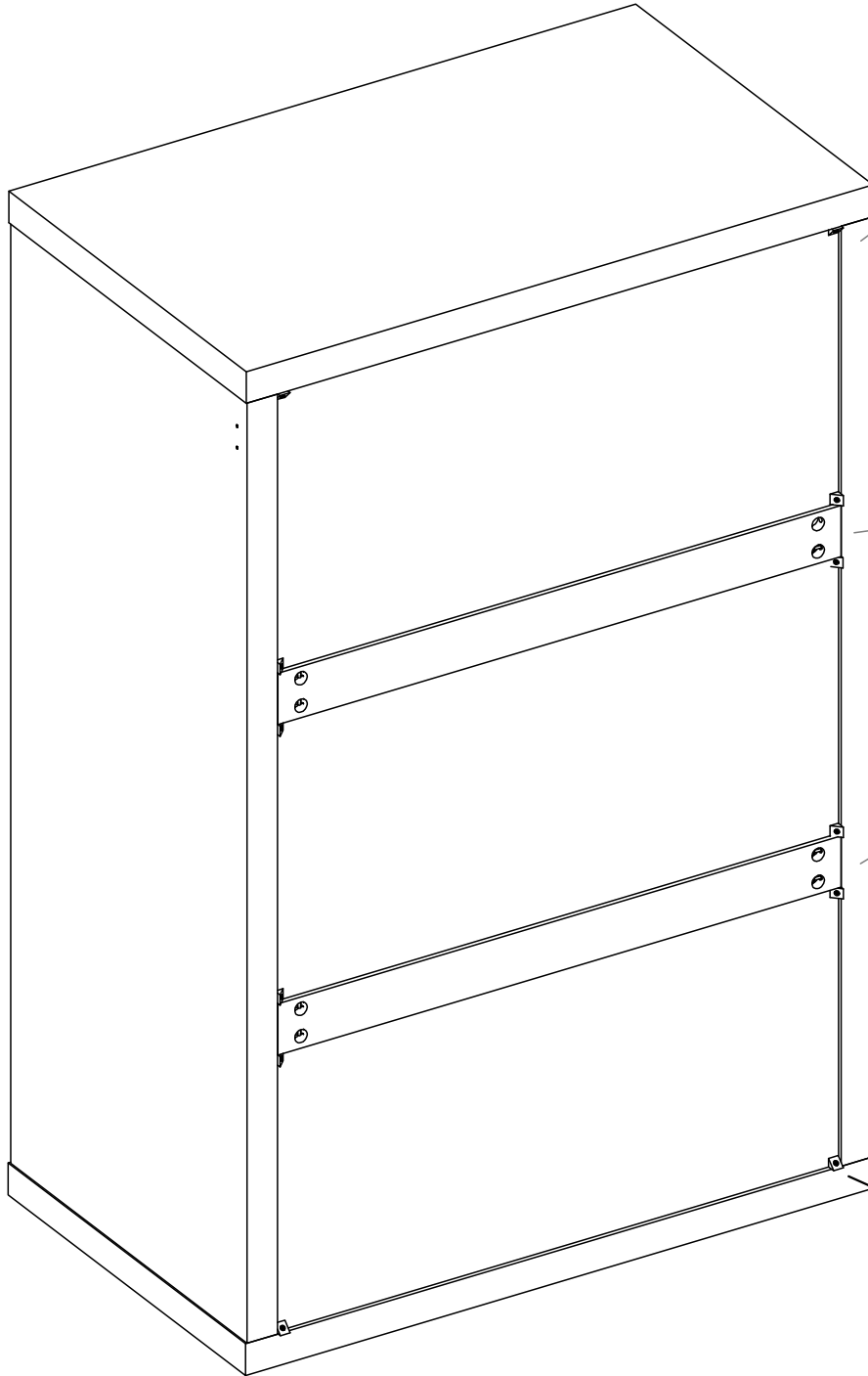

19

I



x4

J

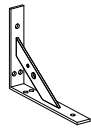

x2

K



K1



K2



K3



K4

x2

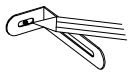
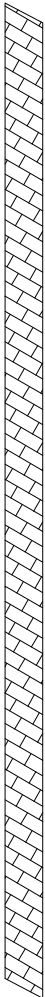
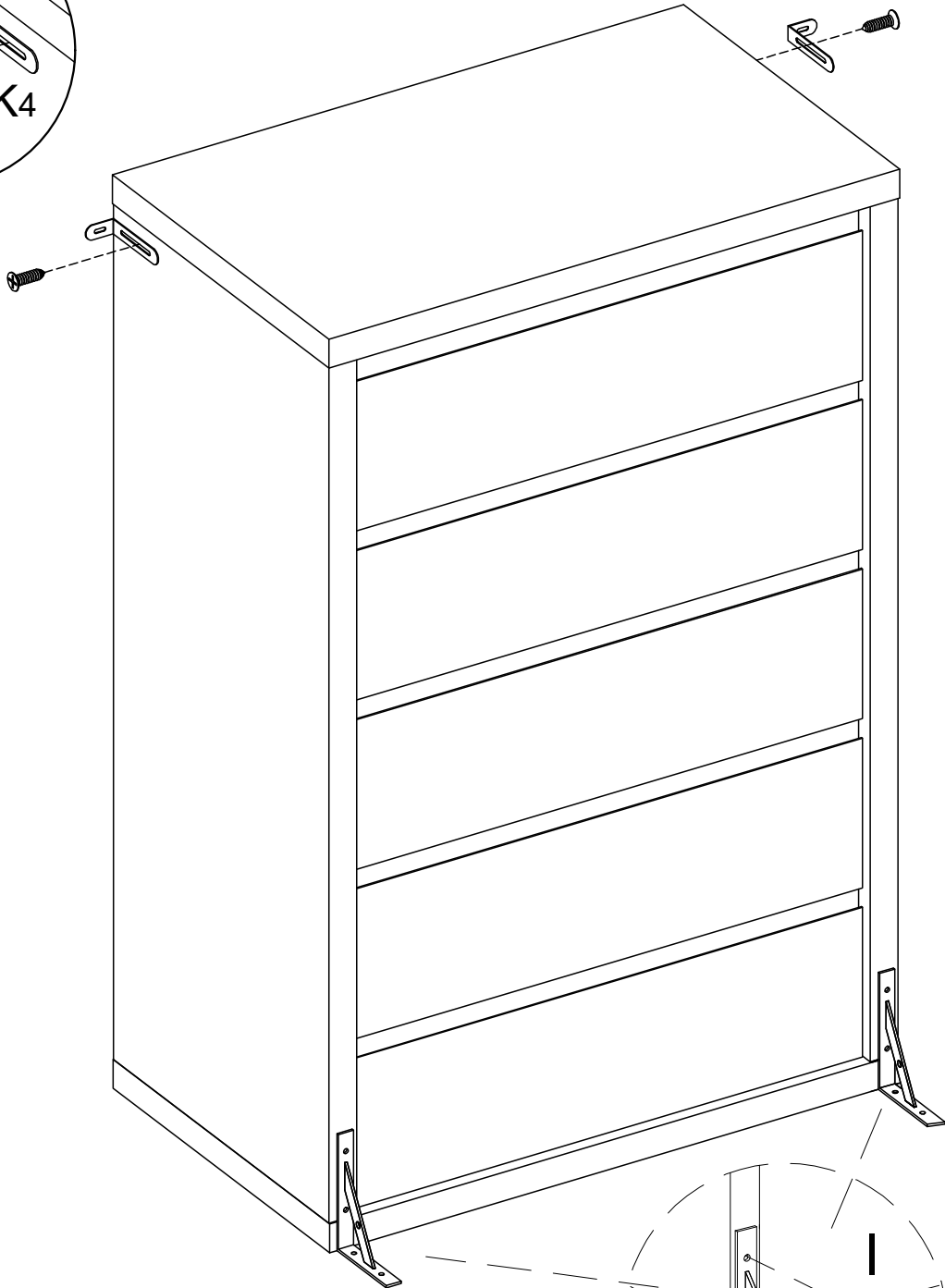
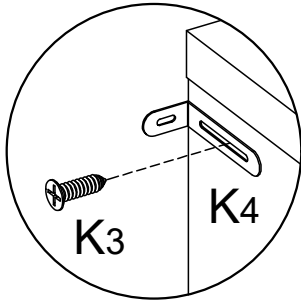

Step 1

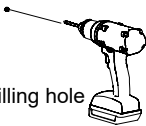

drilling hole

Step 2



K1

Step 3

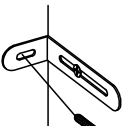

Step 4

K2

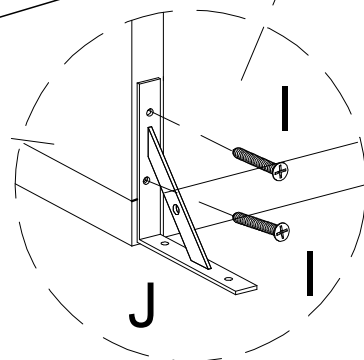

19

J

Thank You!

For Purchasing from us

Despite our reinforced packaging, transit mishandling can sometimes occur. In the rare event that your product arrives damaged, we're here to assist you. If your product is in perfect condition, you can disregard this message.

If you discover any damage upon receipt of your package, please contact our after-sales mailbox immediately.

Additionally, we kindly request your assistance in filing a claim against the shipping carrier for the mishandling of your package. Please help us by providing clear photos as follows:

- ★ **Complete Shipping Label (Express Delivery Waybill):** Take a clear image of the entire shipping label affixed to the package with visible and legible text and barcodes
- ★ **Exterior Packaging Damage:** Capture a comprehensive photo showing the damaged exterior of the shipping package.
- ★ **Interior Item Damage:** Provide images focusing on the damaged areas of product

Your cooperation is invaluable, and we assure you that we're committed to resolving this issue promptly. Your satisfaction remains our top priority.

Thank you for your understanding and assistance.

Best regards,