

# Adirondack Collection Folding & Reclining Adirondack Chairs

## Assembly Guide

### IMPORTANT!

DO NOT fully tighten the bolts until all bolts are started.  
Once all bolts are inserted, go back & tighten all the bolts.

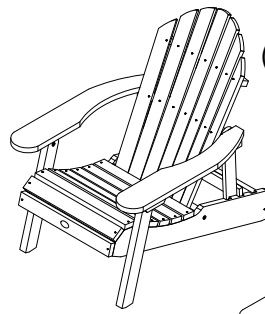

AD-CHL1  
(7) BACK SLATS

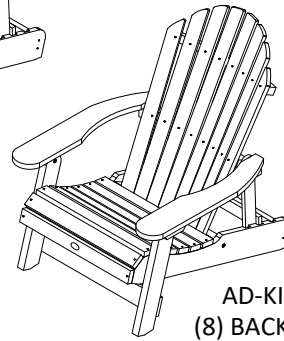

AD-KING1  
(8) BACK SLATS

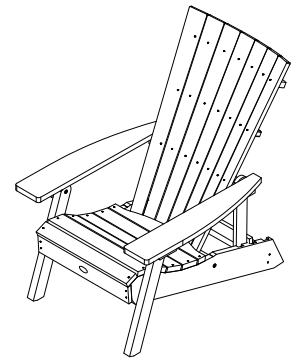

AD-ADRID29A

### HARDWARE INCLUDED

**A**  Qty: 10  
#7 x 2-1/4"  
AD-CHL1 (Qty: 4)  
AD-ADRID29A (Qty: 4)  
AD-KING1 (Qty: 10)

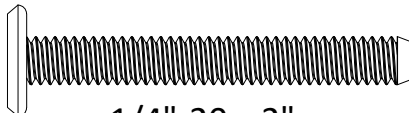
**B**  Qty: 4  
1/4"-20 x 2"

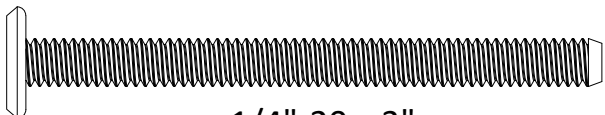
**C**  Qty: 2  
1/4"-20 x 3"

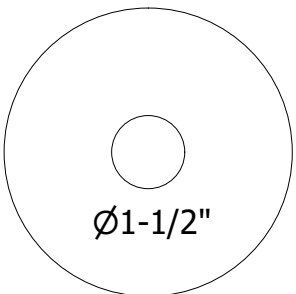
**D**  Qty: 2  
Ø1-1/2"

### TOOLS INCLUDED

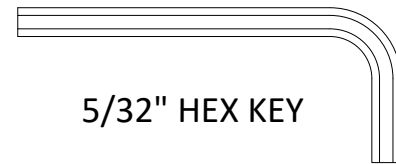

5/32" HEX KEY

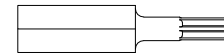

T-15 TORX BIT

### CUSTOMER SUPPLIED TOOLS

Cordless screwdriver/drill OR  
Multi-bit handle for the Torx Bit

### STEPS 1-2

Attach Seat to Back using Bolt B.

Repeat on other side.

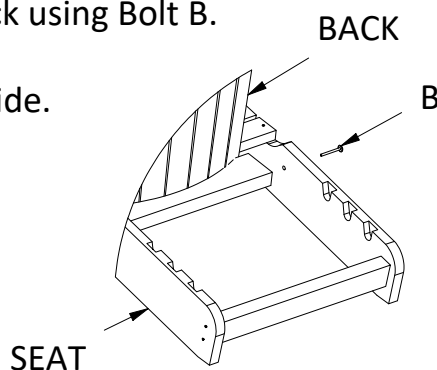

### STEP 3

Attach Back Support Brace to Back Support Sides with (4) A Screws.

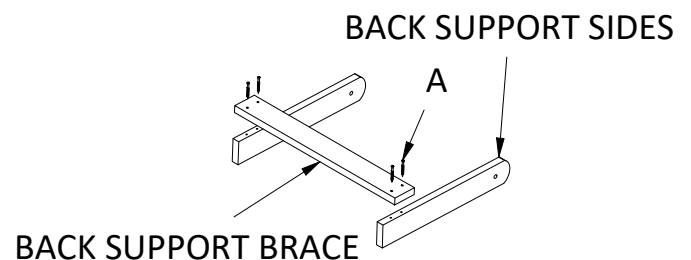

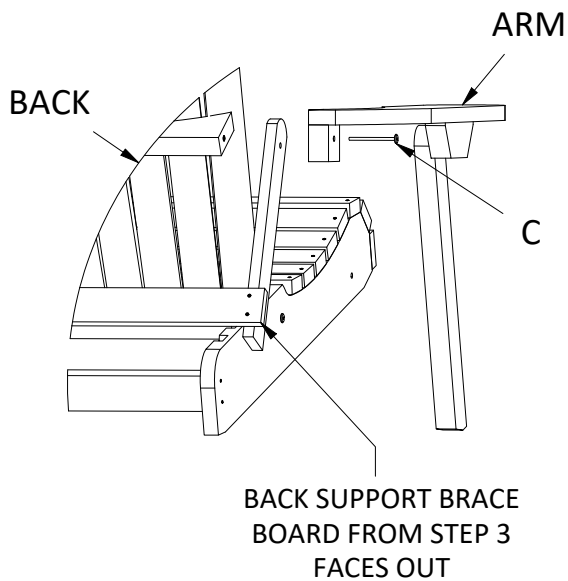

#### STEP 4-5

Attach Arm to Back using Bolt C. Insert Bolt from Arm, through Back Support Side, into the Back. (Note: Screws face outward on Back Support Brace)

Repeat on other side.

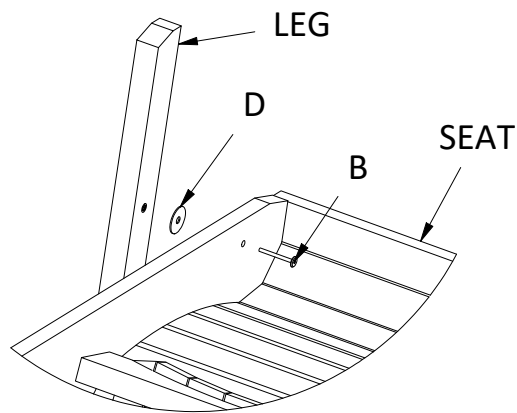

#### STEP 6-7

Turn chair over. Place Washer D in between Seat and Leg. Attach using Bolt B.

Repeat on other side.

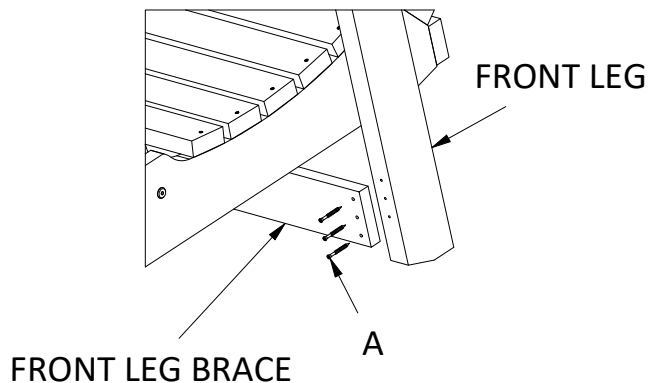

#### STEP 8-9 FOR AD-KING1 MODELS with included Front Brace ONLY

\*\*A Front Leg Brace is not included with AD-CHL1 and AD-ADRID29A Models.\*\*

Attach Front Leg Brace to Front Leg using (3) A Screws.

Repeat on other side.

### IMPORTANT NOTE!

NEVER adjust the level of recline while you are sitting in the chair, or while anyone else is in the chair. Always adjust with an empty chair and ensure that the back support is completely secure in the recline slots on each side of the chair. To fold the chair, lift the back support and gently push down on the back of the chair. The chair will collapse down to the floor level.