









Read this instruction carefully. See hardware and furniture part list for guidance.
 Be sure all parts are complete, before you assemble. Place all wooden furniture parts on a clean and flat soft surface to prevent from being scratched.
 Follow the figure to start assembling.

CAUTION : 1. Do not FULLY - TIGHTEN the nuts or nuts bolts until they are ready for assembly.
 2. Do not OVER - TIGHTEN the nuts or bolts to avoid causing damages to the thread.
 3. Keep all hardware parts out of reach of children.

NOTE : THE LIST AND QUANTITY SHOWN ARE FOR 1 UNIT ASSEMBLY.

Tools needed : Screwdriver (not provided).

PART LIST			
ITEM	DESCRIPTION	BOX	QTY
A	HEADBOARD	1	1 PC
B	HEADBOARD LEG	1	2 PCS
C	HEADBOARD SUPPORT WOOD (1)	1	2 PCS
D	HEADBOARD SUPPORT WOOD (2)	1	2 PCS
E	HEADBOARD SUPPORT RAIL	1	1 PC
F	FOOTBOARD	2	1 PC
G	SIDE RAIL	3	2 PCS
H	CENTER RAIL	3	1 PC
I	CENTER SUPPORT LEG	3	3 PCS
J	CENTER SUPPORT WOOD	3	2 PCS
K	BED SLAT	2	26 PCS
L	BED LEG	2	4 PCS

HARDWARE LIST (BOX : 2)			
ITEM	DESCRIPTION		QTY
1	JCBB BOLT M8 x 45mm		14 PCS
2	M8 FLAT WASHER		14 PCS
3	M8 SPRING WASHER		14 PCS
4	WOOD SCREW M3.5 x 16mm		8 PCS
5	WOOD SCREW M4 x 20mm		2 PCS
6	BED SLAT SIDE FITTER		26 PCS
7	BED SLAT CENTER FITTER		13 PCS
8	M5 ALLEN KEY (BALL SHAPE)		1 PC

STEP 1

Take out HEADBOARD LEG (B) & HEADBOARD SUPPORT RAIL (E) from the HEADBOARD BACK (A).

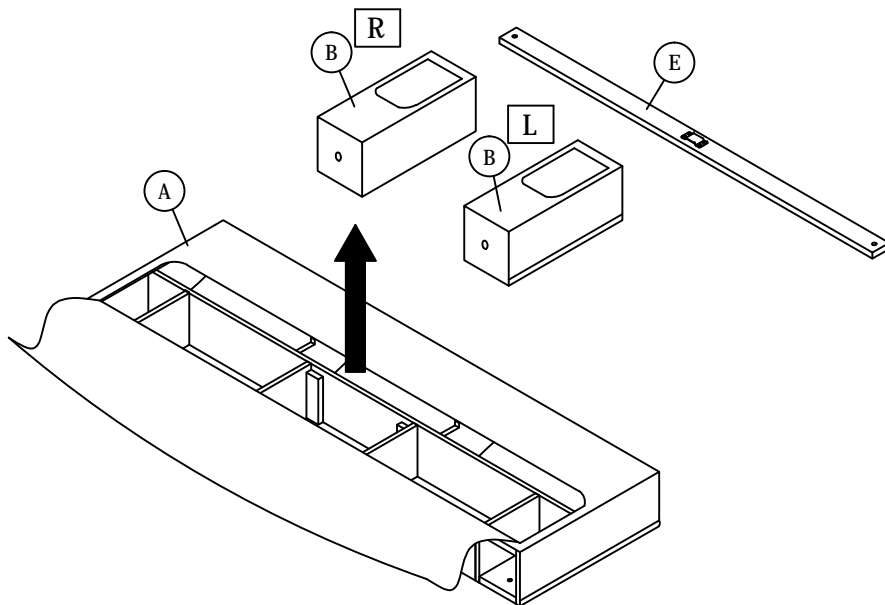

STEP 2

Take out HEADBOARD SUPPORT WOOD 1 (C) & HEADBOARD SUPPORT WOOD 2 (D) for the HEADBOARD LEG (B).

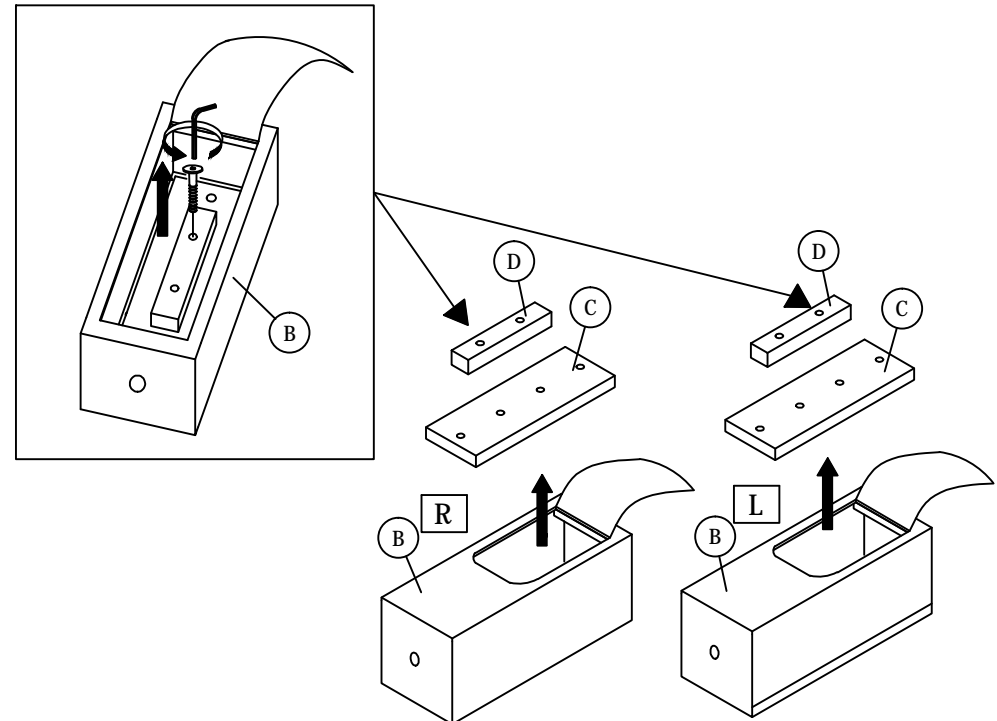

ASSEMBLY INSTRUCTIONS

STEP 3

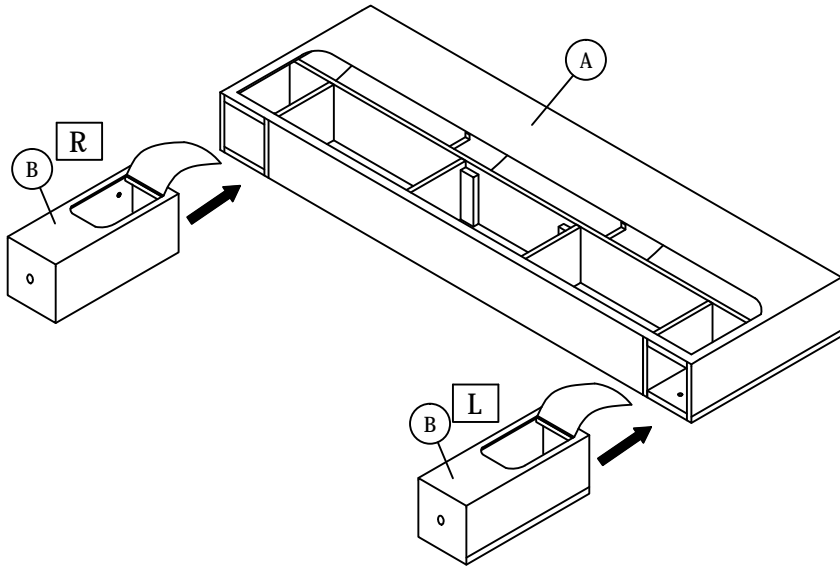

STEP 4

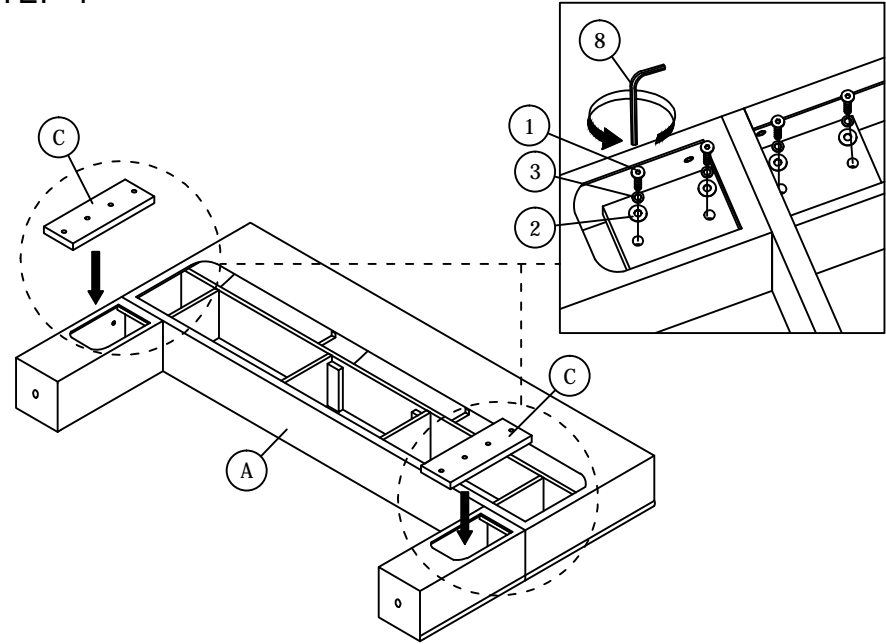

STEP 5

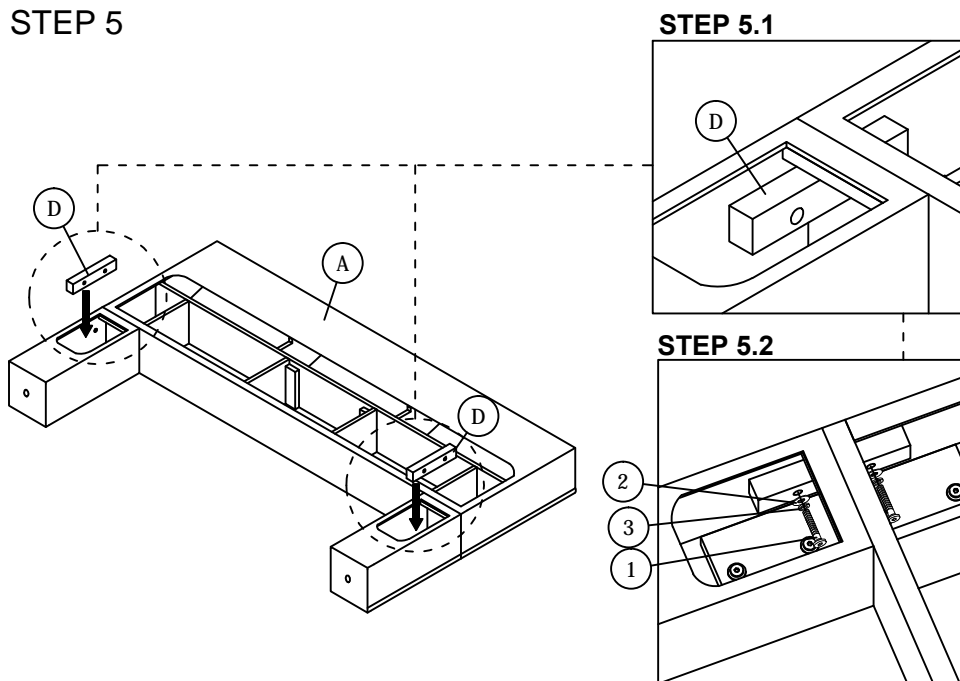

STEP 6

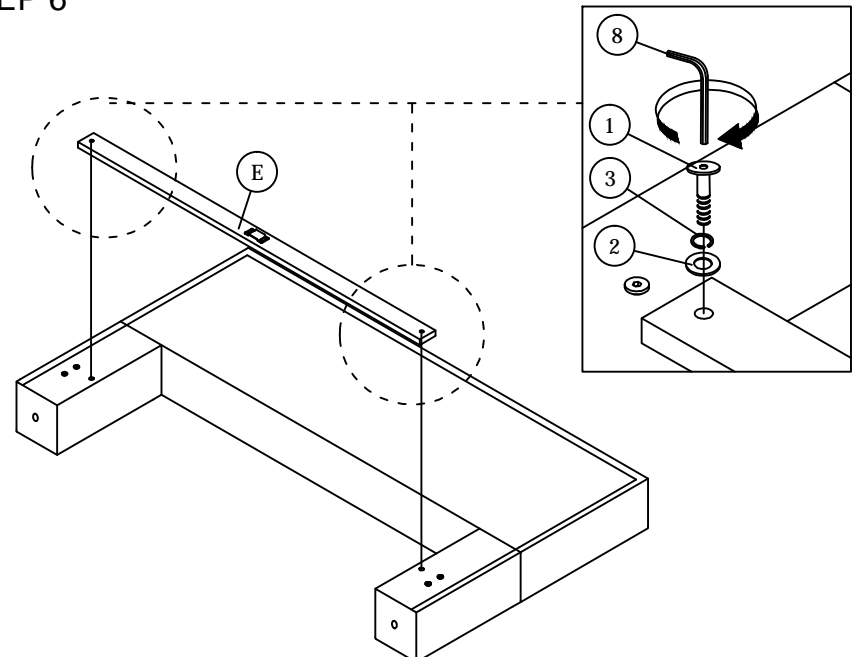

ASSEMBLY INSTRUCTIONS

STEP 7

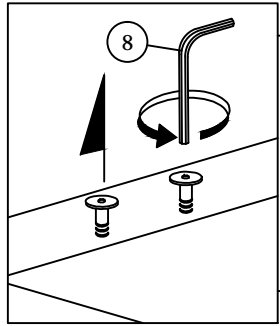

Loosen the pre-inserted bolt on the headboard and footboard using Allen key ball shape (8).

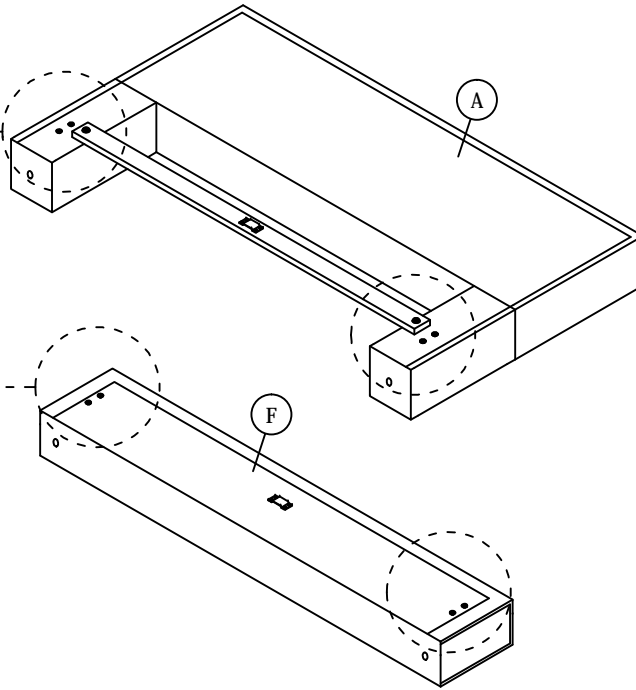

STEP 8

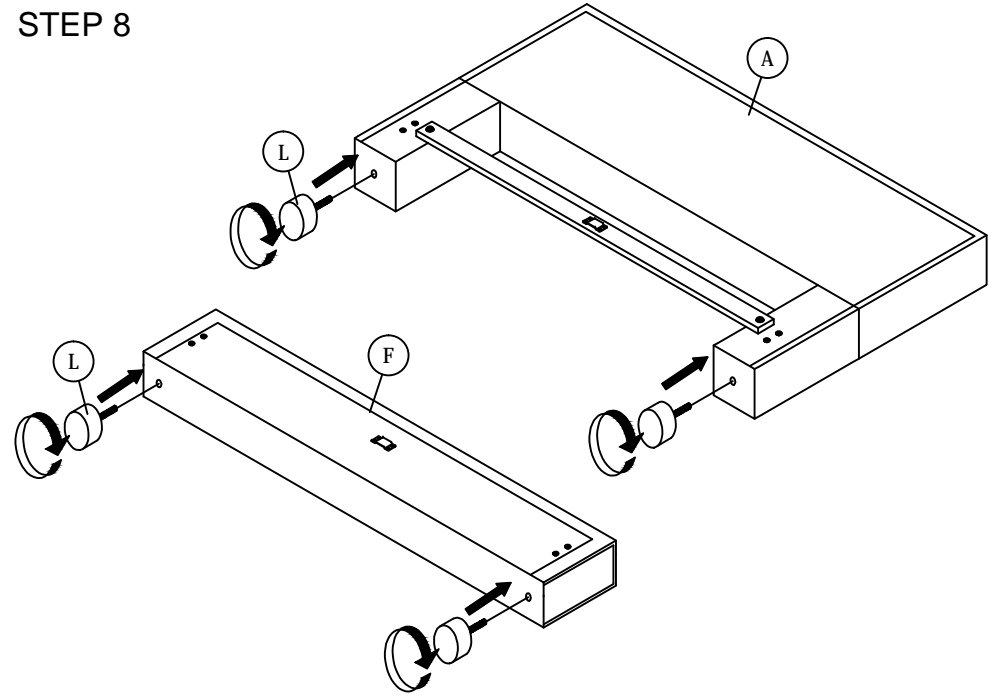

STEP 9

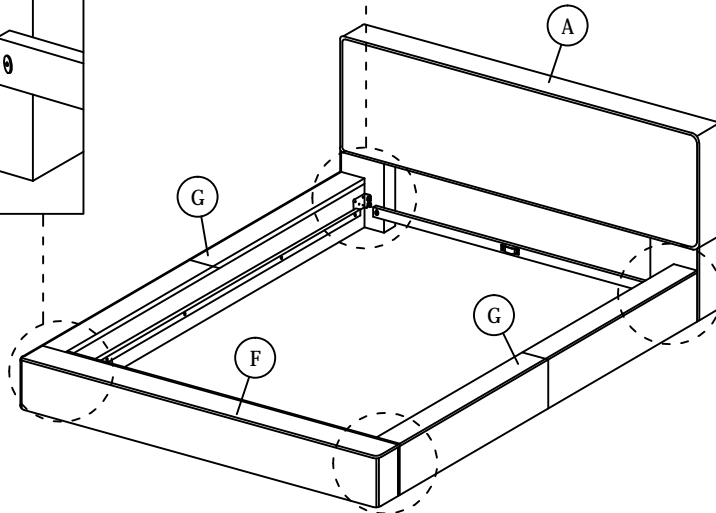
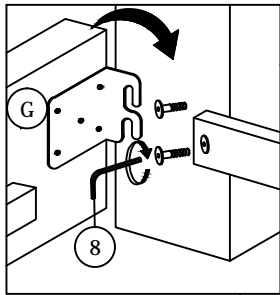

STEP 10

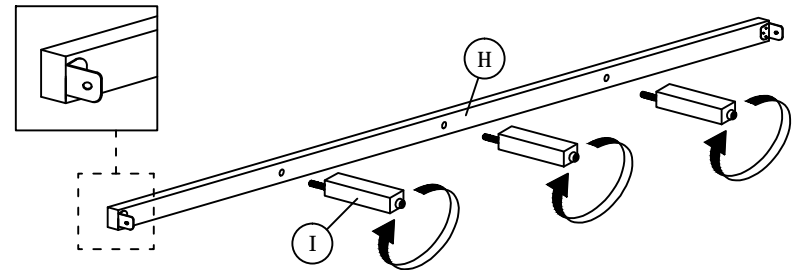

ASSEMBLY INSTRUCTIONS

STEP 11

STEP 10.1

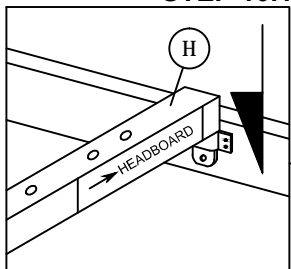

Note: Make sure the sticker
"-> HEADBOARD"
faced to
headboard [A]

STEP 10.2

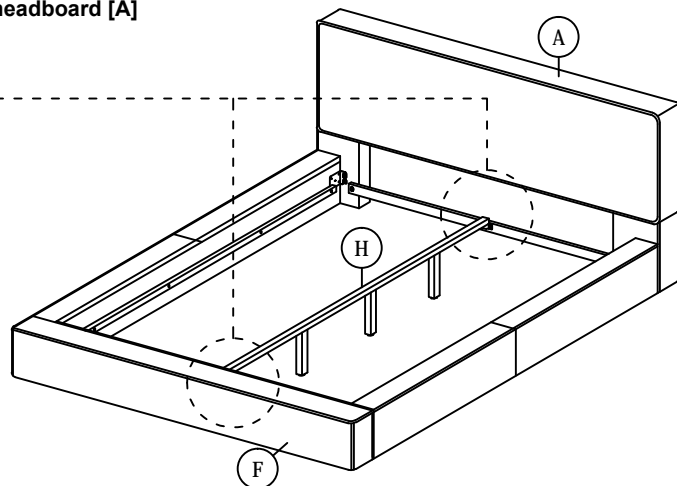
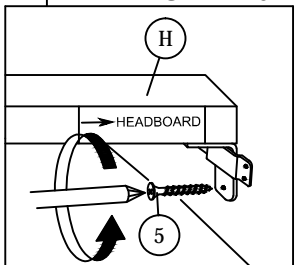

STEP 12

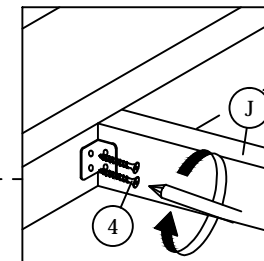
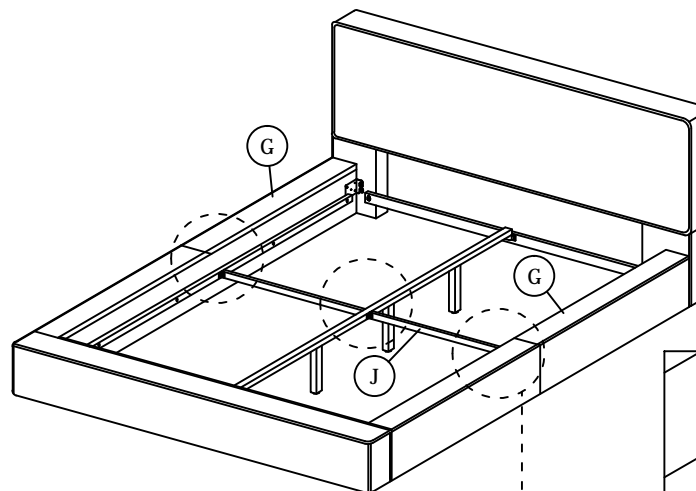

STEP 13

STEP 13.1

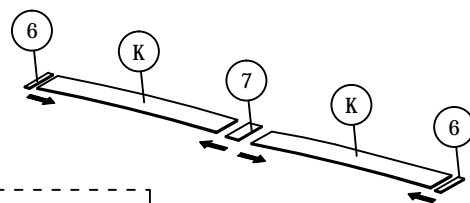
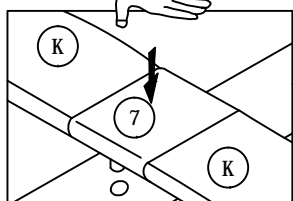

STEP 13.2

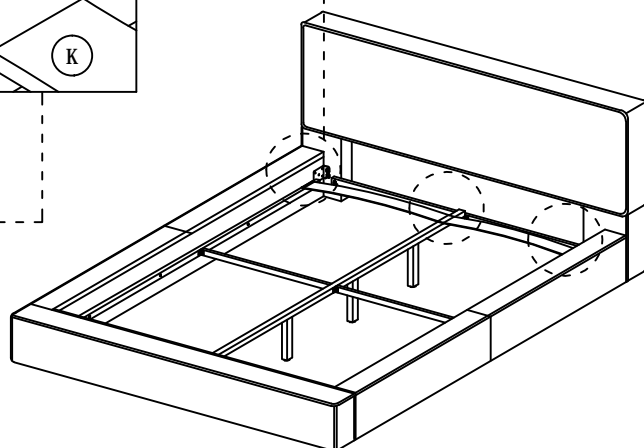
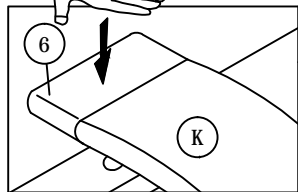

STEP 14

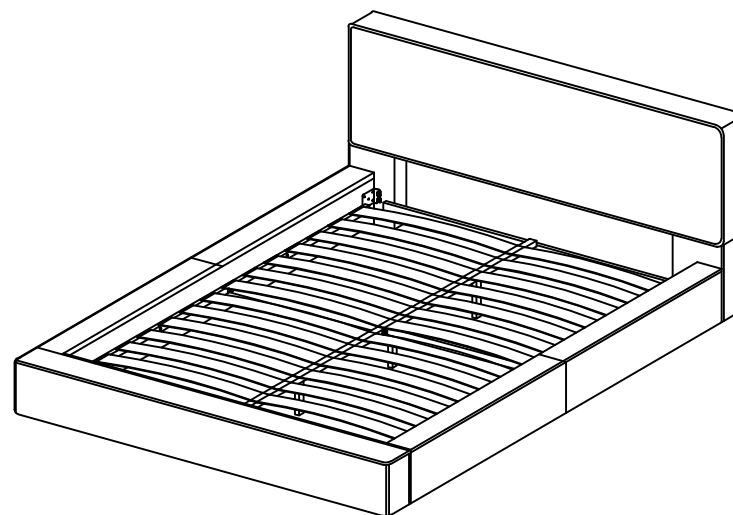

* When moving the bed position, the center support legs
must be adjusted or straightened to avoid any broken problems.