

JY9894BR01

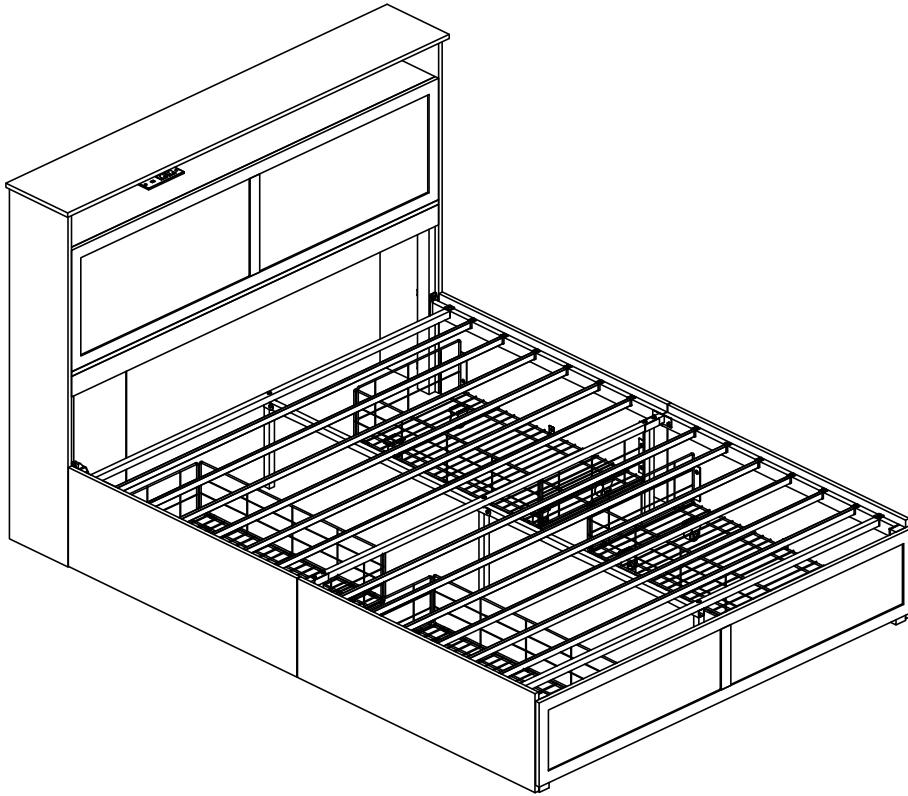

As this item contains many parts, please read the installation instruction carefully before installation. Please use tools properly and carefully. If you have any questions about the product and installation, please contact us.

hosoteservice@gmail.com

Our professional after-sales team will serve you online all day.

Before You Start

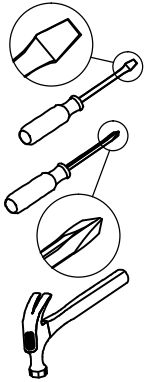

- ✓ Read through each step carefully and follow the proper order
- ✓ Separate and count all your parts and hardware
- ✓ Give yourself enough room for the assembly process
- ✓ Have the following tools: Flat Head Screwdriver, #2 Phillips Head Screwdriver and Hammer
- ✓ Caution: If using a power drill or power screwdriver for screwing, please be aware of to slow down and stop when screw is tight. Failure to do so may result in stripping the screw. (Assembly speed can be increased by using electric screwdriver)

Helpful Hints

PEOPLE NEEDED FOR ASSEMBLY: 1-2

- Open your item in the area you plan to keep it to avoid excessive heavy lifting.



- Identify, sort and count the parts before attempting assembly.

- Compression dowels are lightly tapped in with a hammer.



- Make sure to always face the point on the top of the Cam Lock towards the outer edge.



- If there is a back panel in the package, please install it to make sure your unit is complete and sturdy.



- Please fix all the screws provided for the back panel which can enhance product stability. If it is difficult to fix it when tightening, it can be fixed with the help of a hammer and then tightened.



- Do NOT use harsh chemicals or abrasive cleaners on this item.

- Never push, pull, or drag your furniture.



Parts Identification 1/2

Not actual size

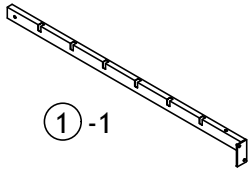

Side rail
Q'ty: 1

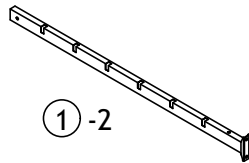

Side rail
Q'ty: 1

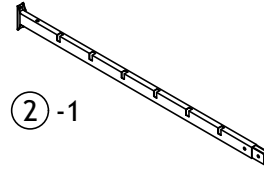

Side rail
Q'ty: 1

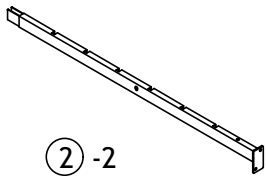

Side rail
Q'ty: 1

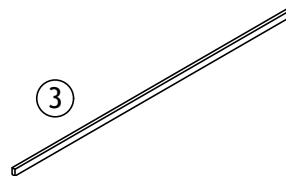

Sparerib strips
Q'ty: 12

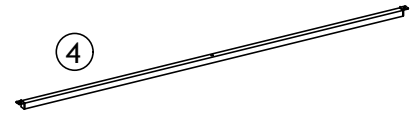

Headstock tail connecting rod and
bed-end transverse tube
Q'ty: 2

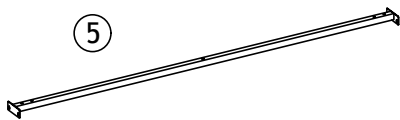

Middle cross bar
Q'ty: 1

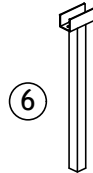

Leg
Q'ty: 2

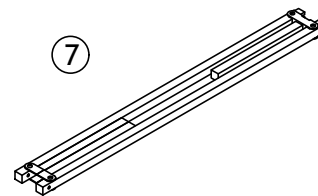

Middle connecting rod
Q'ty: 1

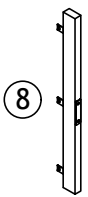

High foot
Q'ty: 1

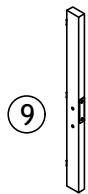

High foot
Q'ty: 1

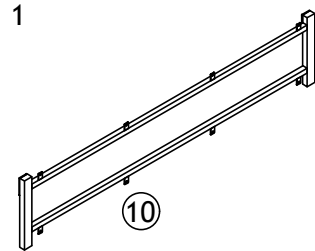

Bed-end frame
Q'ty: 1

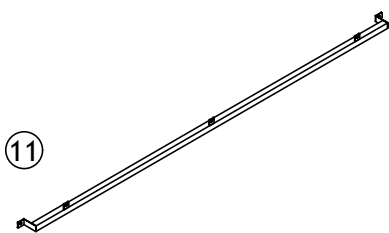

High foot connecting tube
Q'ty: 1

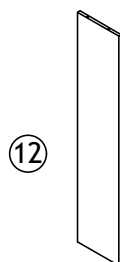

Right baffle
Q'ty: 1

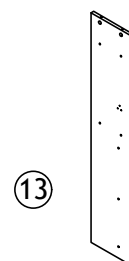

Left baffle
Q'ty: 1

Parts Identification 2/2

Not actual size

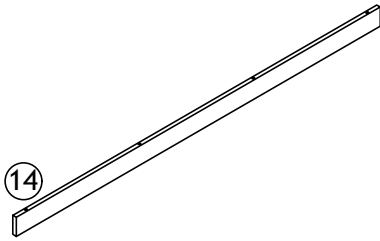

14
Bedside lower backrest panel
Q'ty: 1

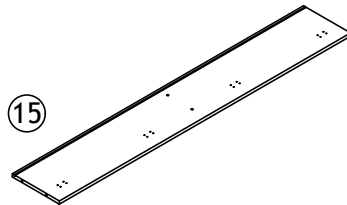

15
Bedside cabinet bottom panel
Q'ty: 1

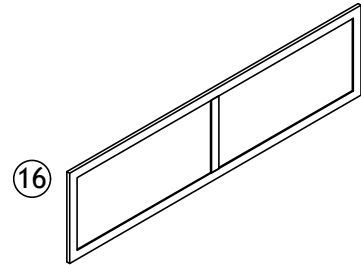

16
Cabinet door
Q'ty: 1



17
Divider panel
Q'ty: 1

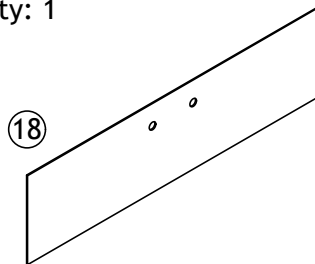

18
Lower back panel
Q'ty: 1

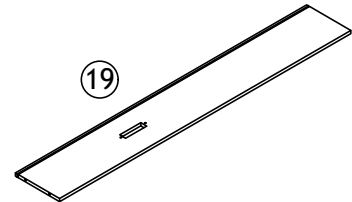

19
Fixed shelf
Q'ty: 1

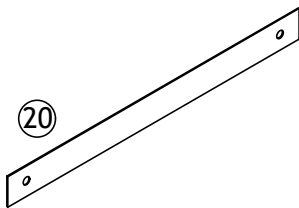

20
Upper back panel
Q'ty: 1

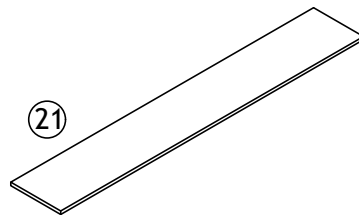

21
Top panel
Q'ty: 1

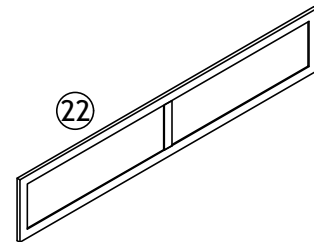

22
Bed tail panel
Q'ty: 1

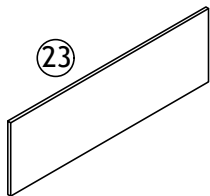

23
Drawer panel
Q'ty: 2

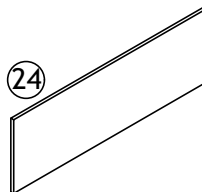

24
Drawer panel
Q'ty: 2

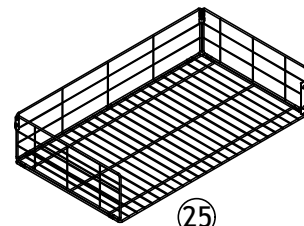

25
Drawer frame
Q'ty: 4

Hardware List

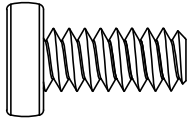

M8 x 13mm

(A) x 4

BOLT
spare: 1

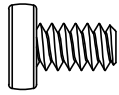

Ø1/4" x 11mm

(B) x 51

BOLT
spare: 5

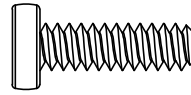

Ø1/4" x 25mm

(C) x 4

BOLT
spare: 1

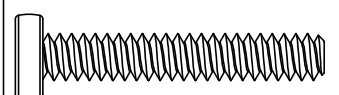

Ø1/4" x 50mm

(D) x 3

BOLT
spare: 1

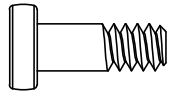

Ø1/4" x 16mm

(E) x 4

BOLT
spare: 1

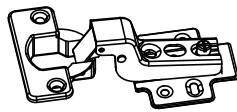

(F) x 4

HINGE

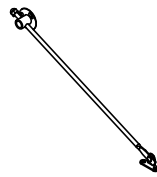

(G) x 2

PULL ROD

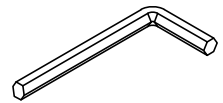

M4

(H) x 1

ALLEN KEY

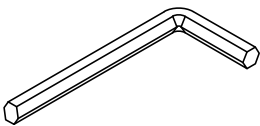

M5

(I) x 1

ALLEN KEY



(J) x 2

CABLE HOLE COVER

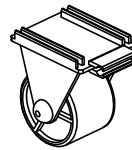

(K) x 16

CASTER



Ø4 x 12mm

(L) x 43

SCREW
spare: 4

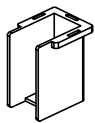

(M) x 24

PLASTIC CAP
spare: 2

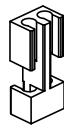

(N) x 8

DRAWER CLIP



(O) x 4

DRAWER CONNECTING
HINGE

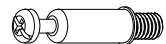

(P) x 22

CAM BOLT
spare: 2



(Q) x 22

CAM LOCK
spare: 2

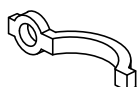

(R) x 7

LED STRIP CLIP



(S)

LED STRIP SET

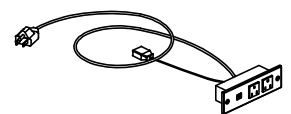

(T)

SOCKET

Parts Identification

Not actual size

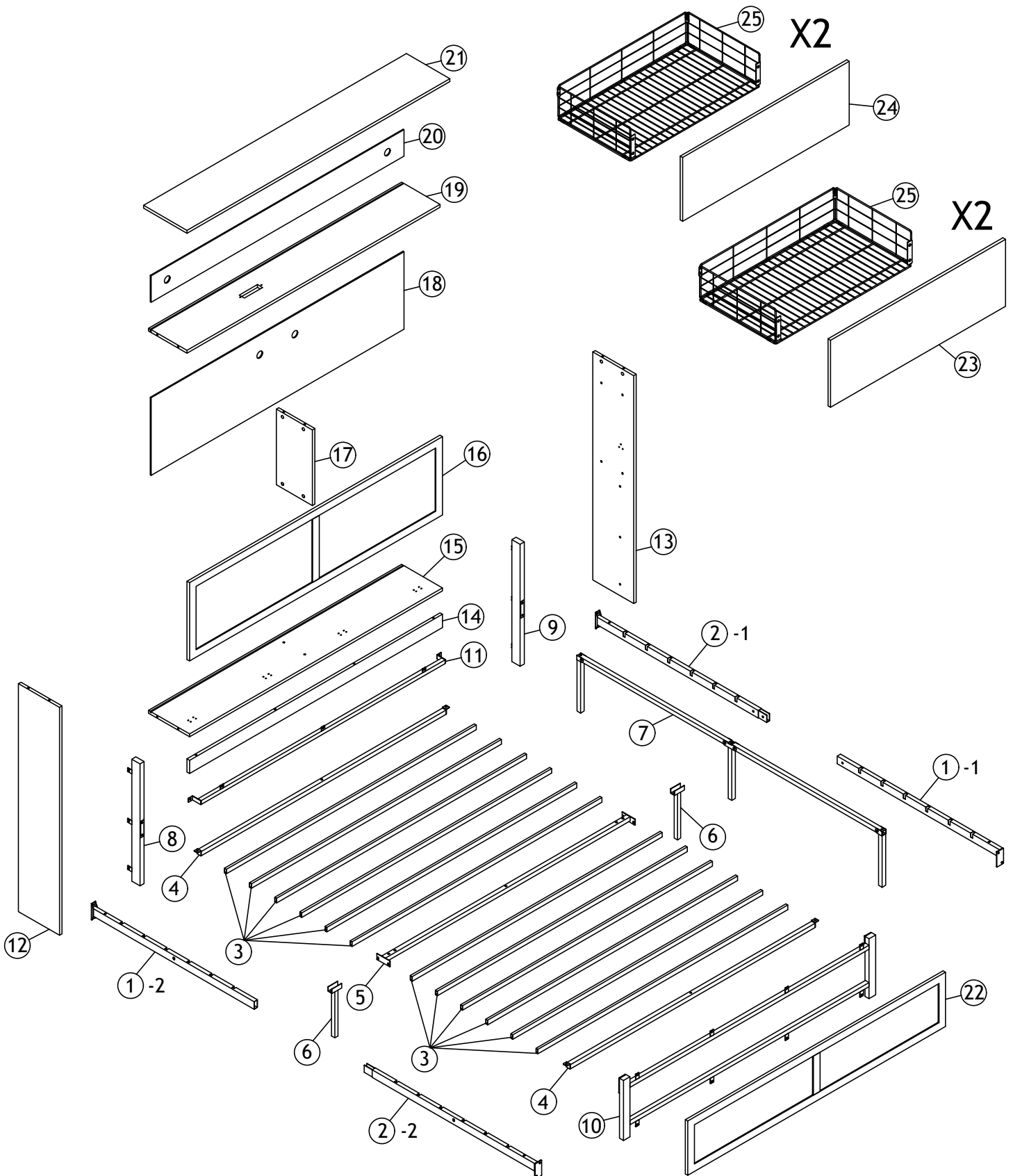

STEP 1

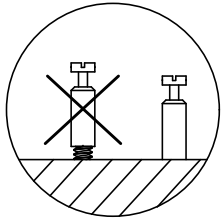
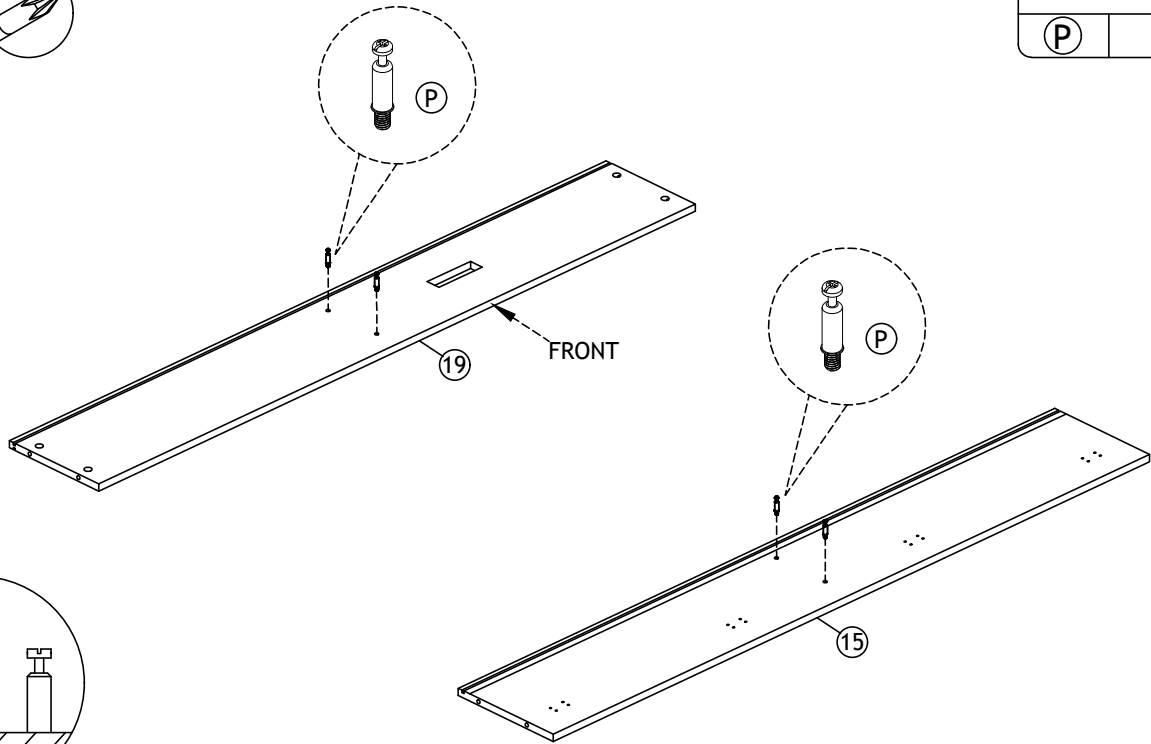
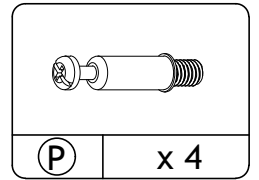
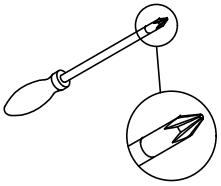

STEP 2

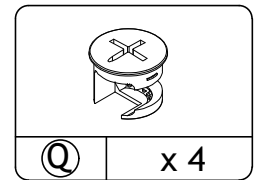
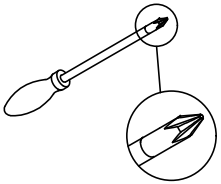

Please be careful not to install the front and back of panel (17) backwards.

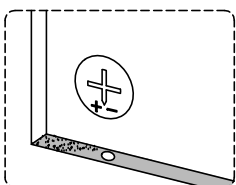
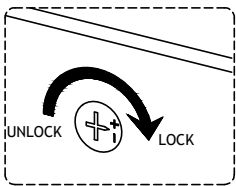
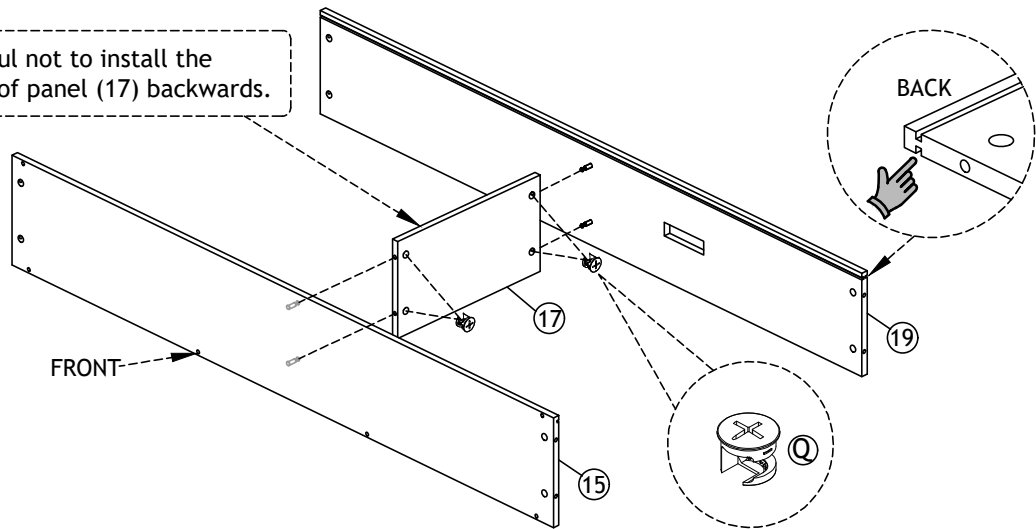

Proper orientation of CAM LOCK

STEP 3

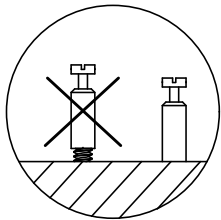
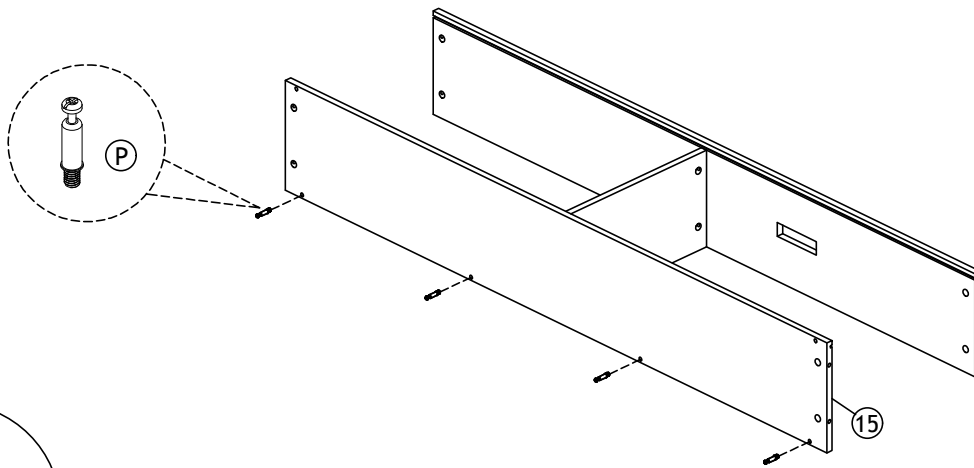
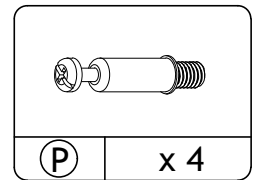
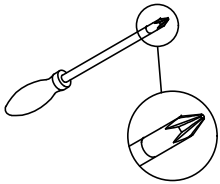

STEP 4

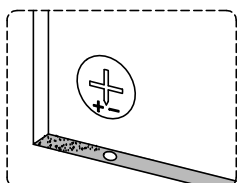
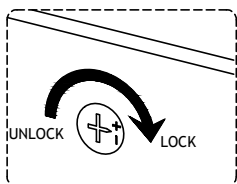
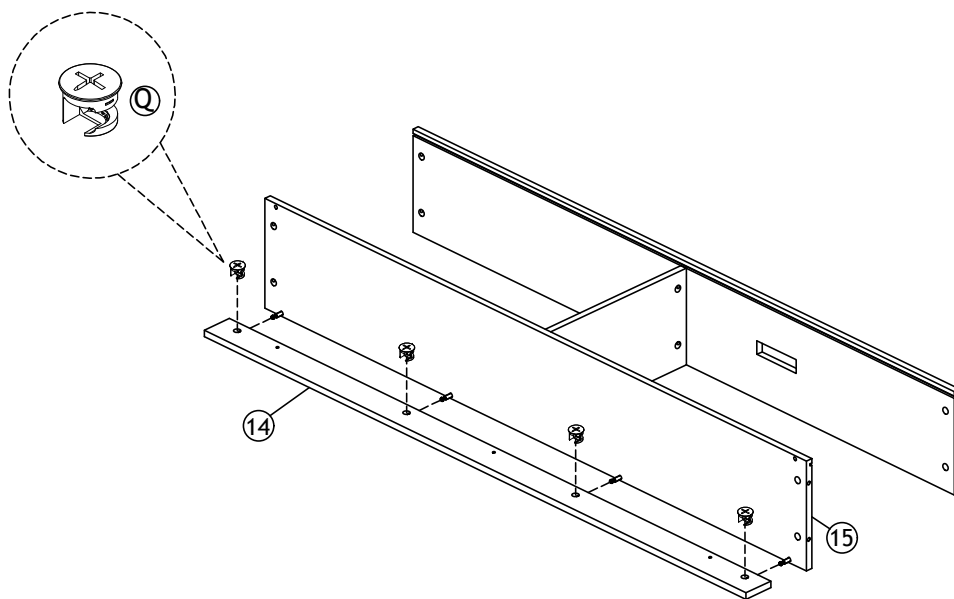
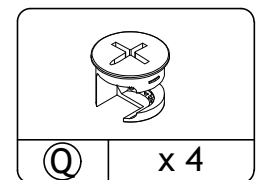
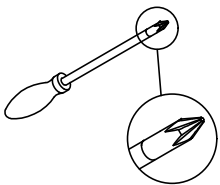

Proper orientation of CAM LOCK

STEP 5

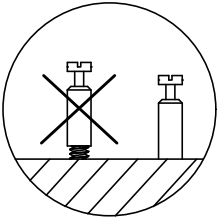
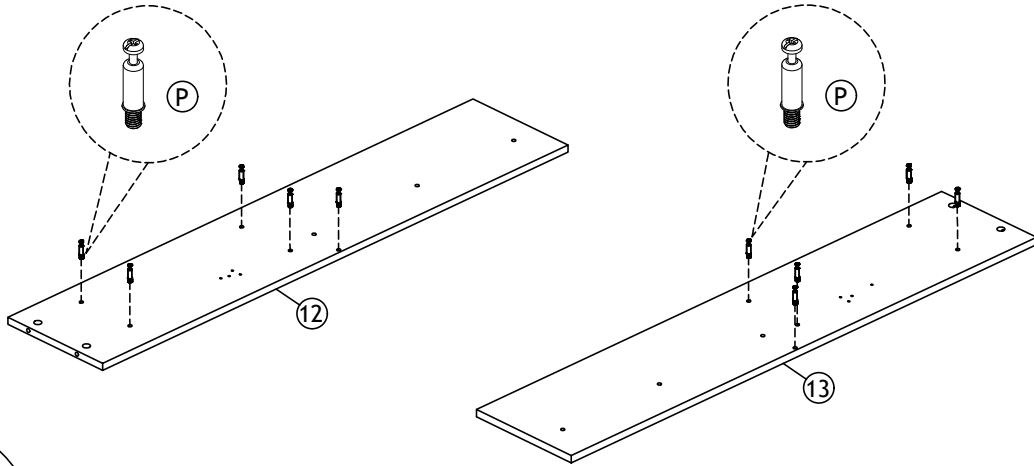
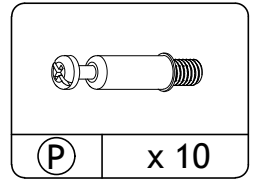
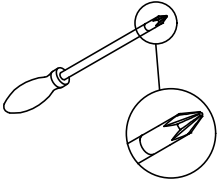

STEP 6

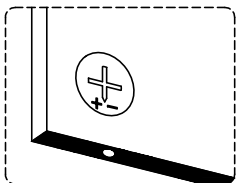
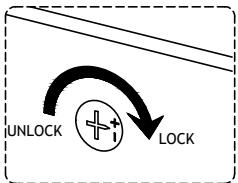
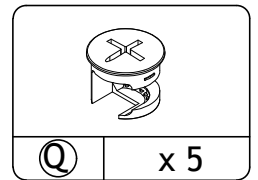
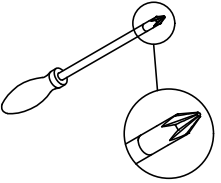

Proper orientation of CAM LOCK

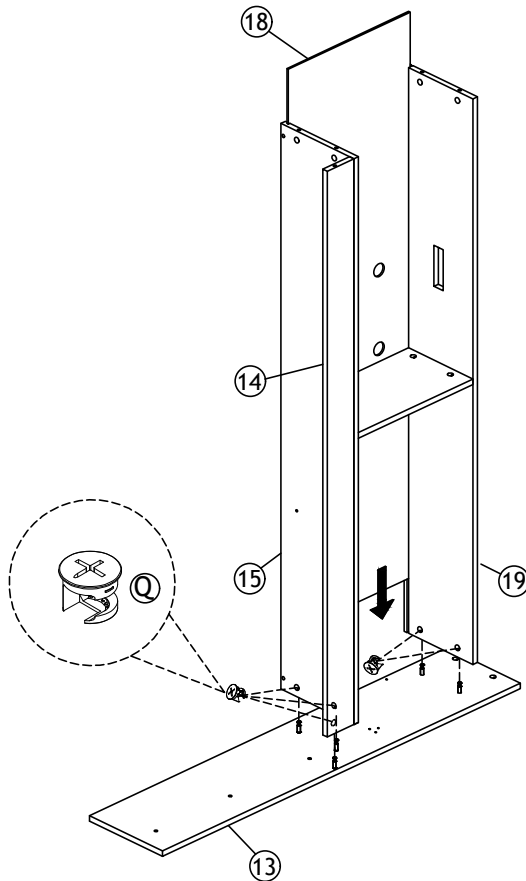

STEP 7

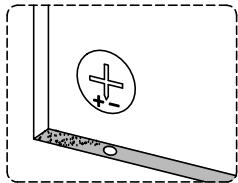
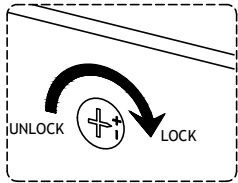
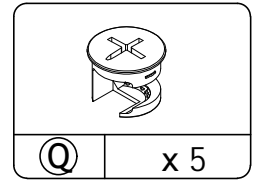
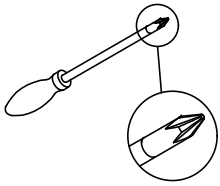

Proper orientation of CAM LOCK

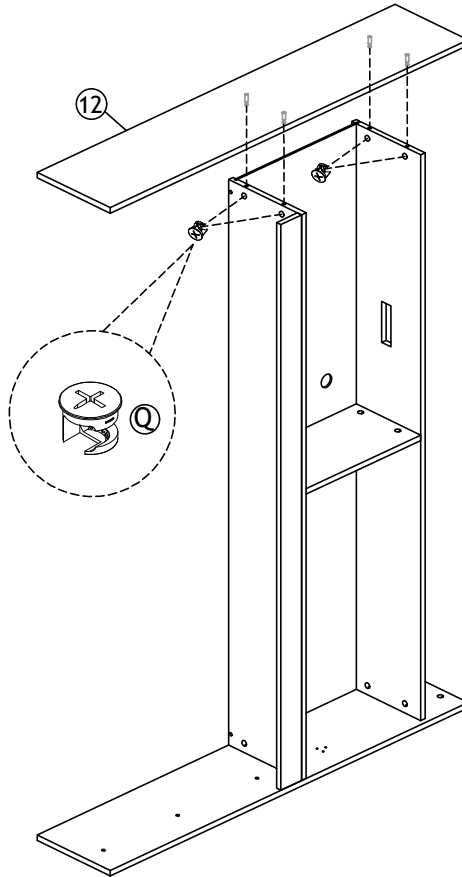

STEP 8

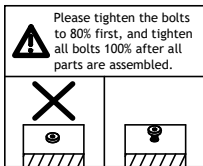

Attention: please be sure not to assemble legs 8 and 9 backwards, otherwise the assembly will not work in the following steps.

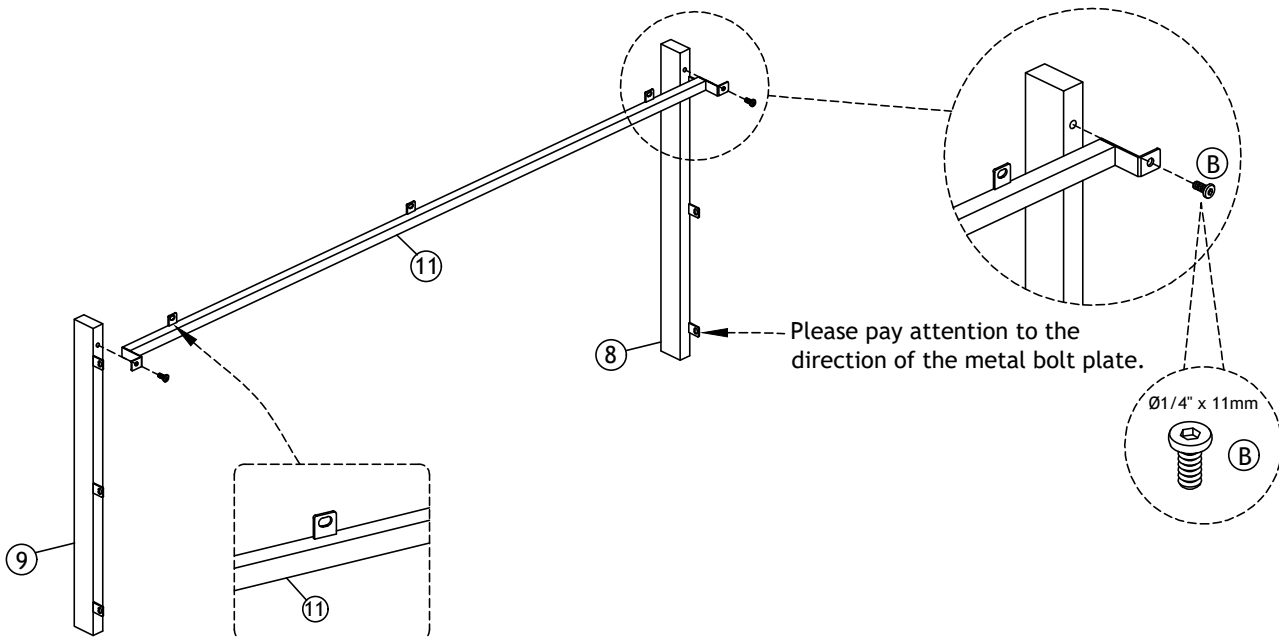
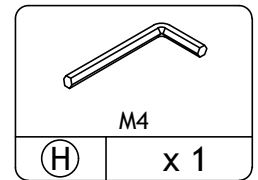
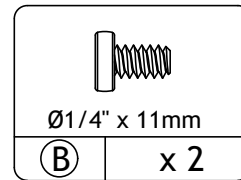

Please pay attention to the direction of the metal bolt plate.

Please pay attention to the direction of the metal bolt plate.

STEP 9

⚠ Please tighten the bolts to 80% first, and tighten all bolts 100% after all parts are assembled.

Ø1/4" x 11mm

(B)	x 9
-----	-----

M4

(H)	x 1
-----	-----

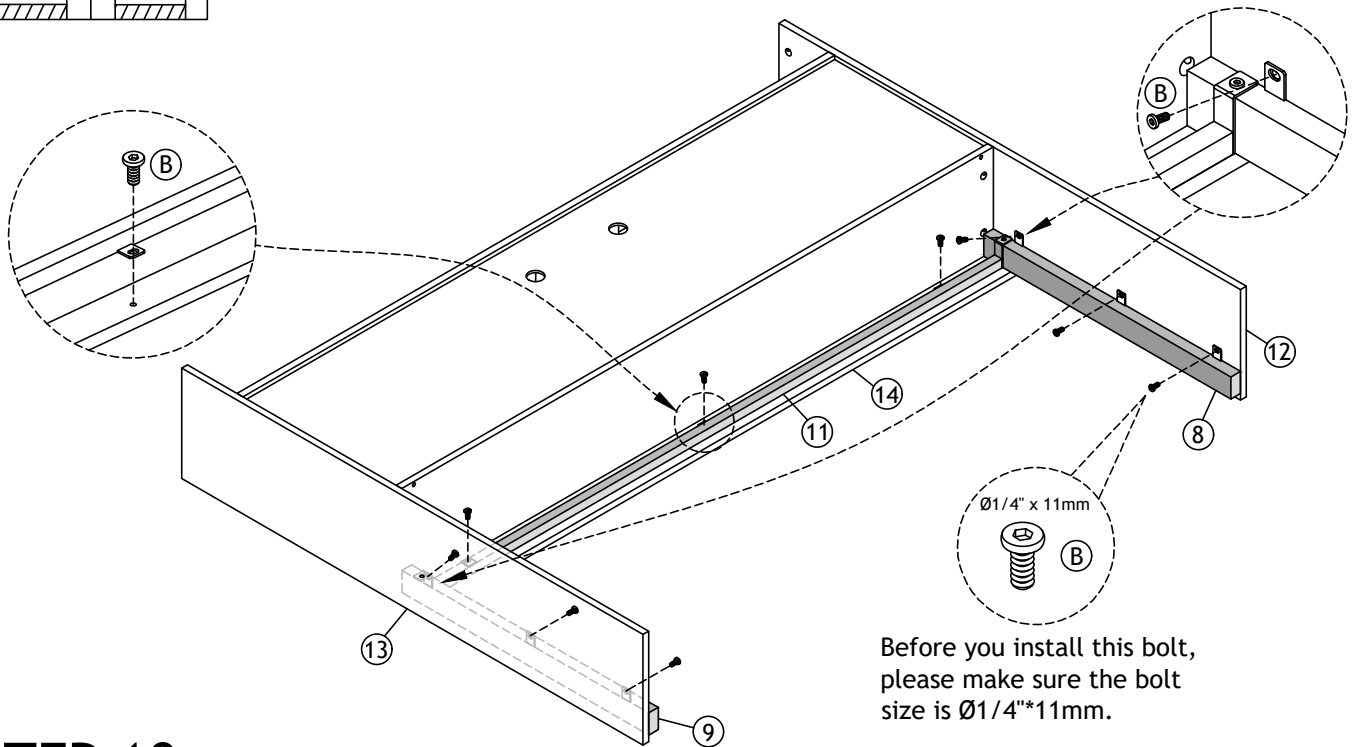

Before you install this bolt, please make sure the bolt size is Ø1/4"*11mm.

STEP 10

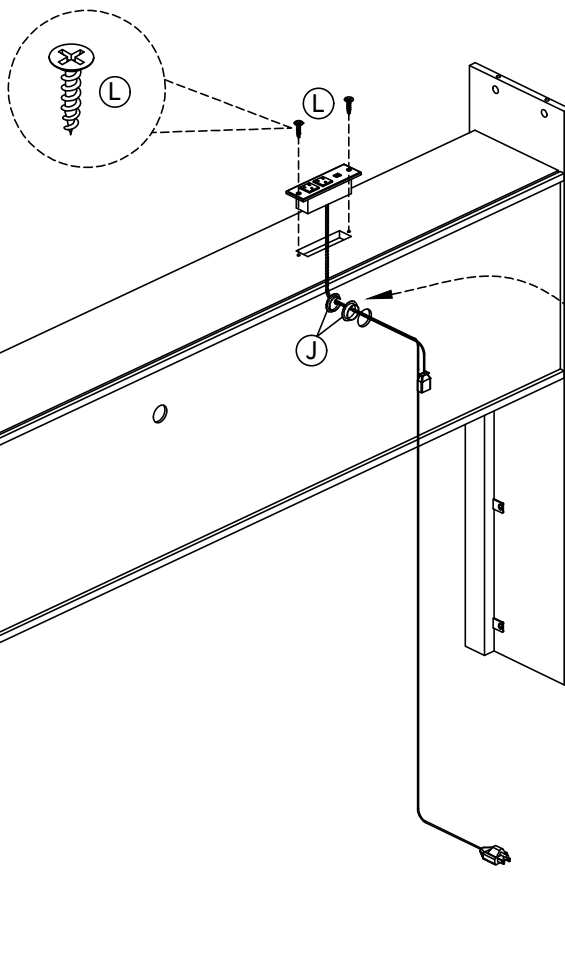

Ø4 x 12mm

(L)	x 2
-----	-----

J-1 J-2

(J)	x 1
-----	-----

T

(T)	x 1
-----	-----

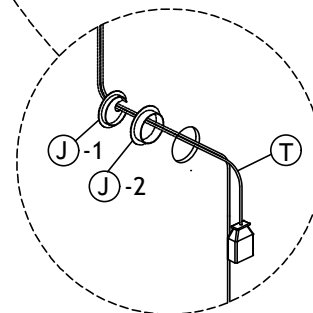

STEP 11

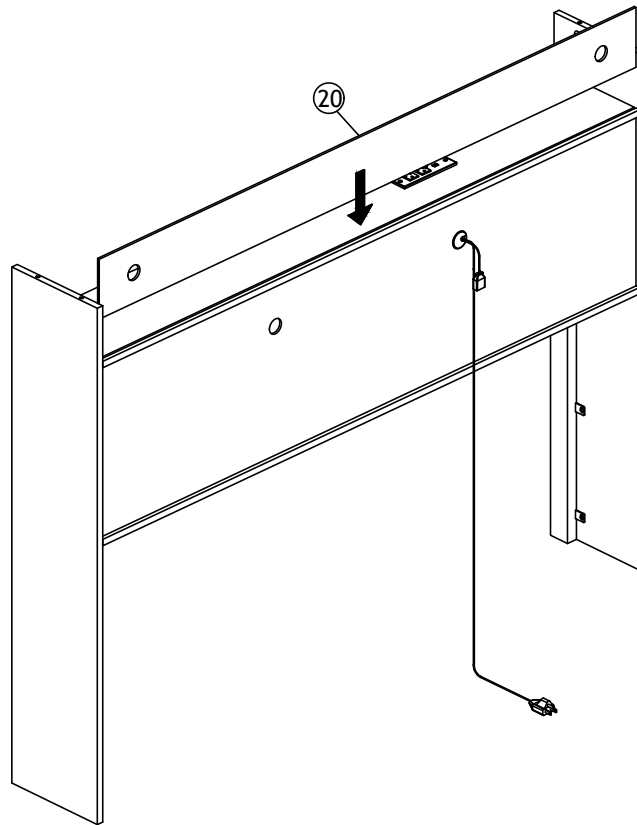

STEP 12

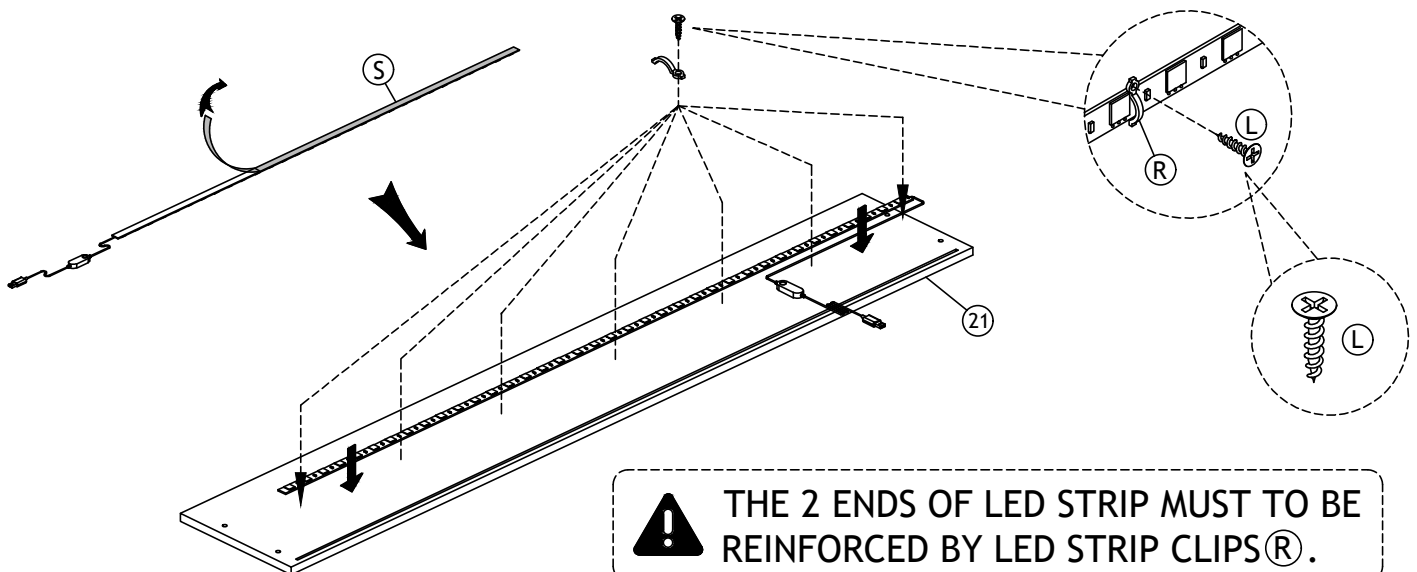
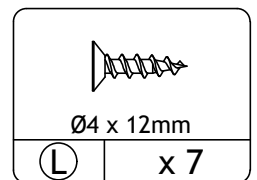
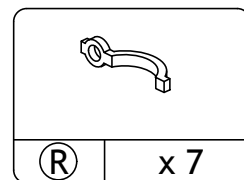
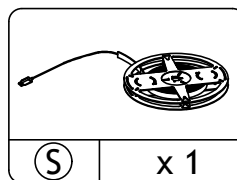
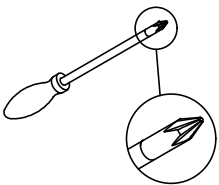

Stick LED strip (S) underneath board (21), then put the clips (R) on LED strip and fasten it with screws (L) to reinforce the LED strip. (There are no screw holes on board (21), you can choose suitable positions to fix the LED strip clips with screws.)

STEP 13

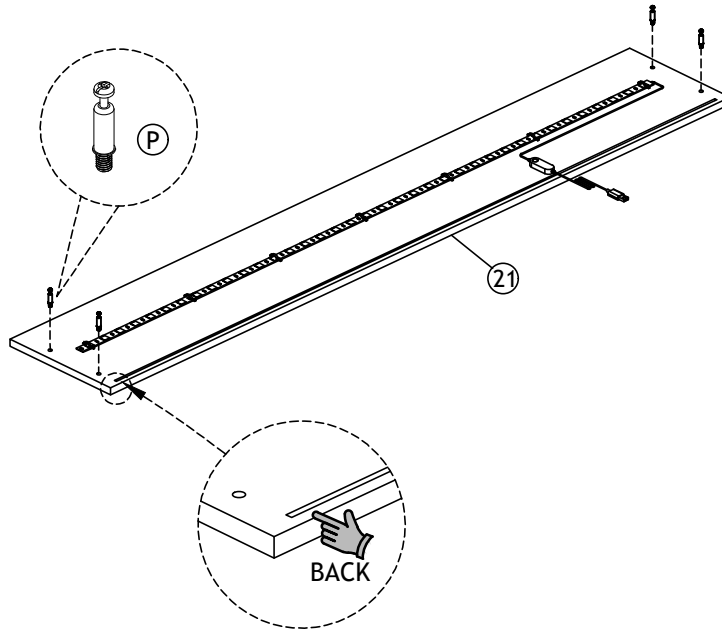
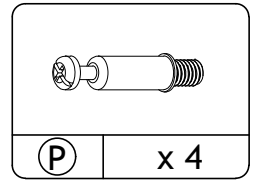
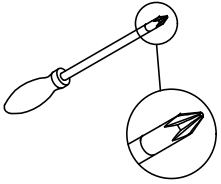

STEP 14

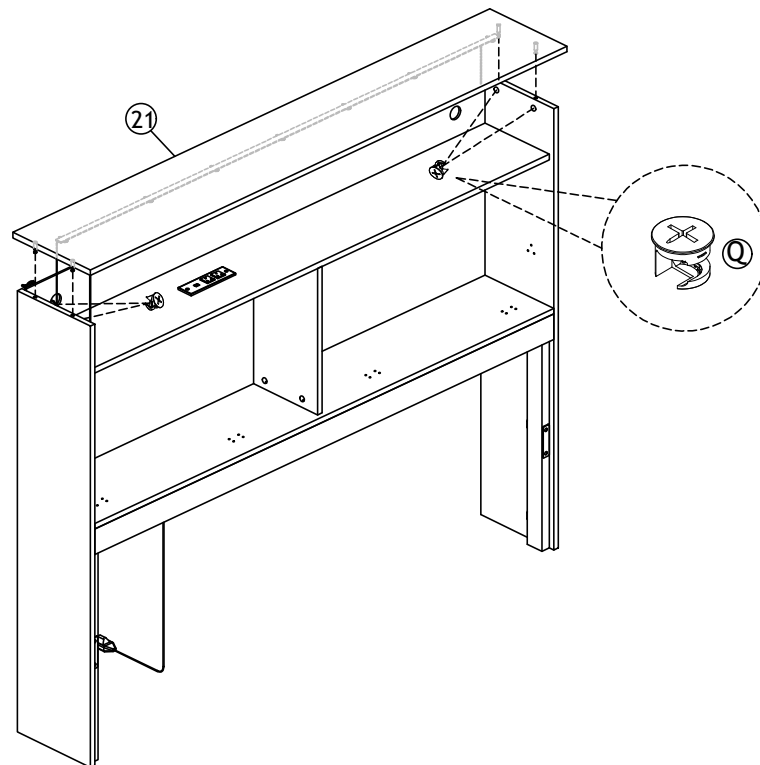
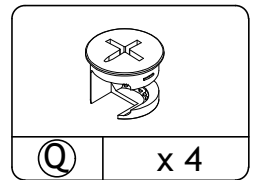

STEP 15

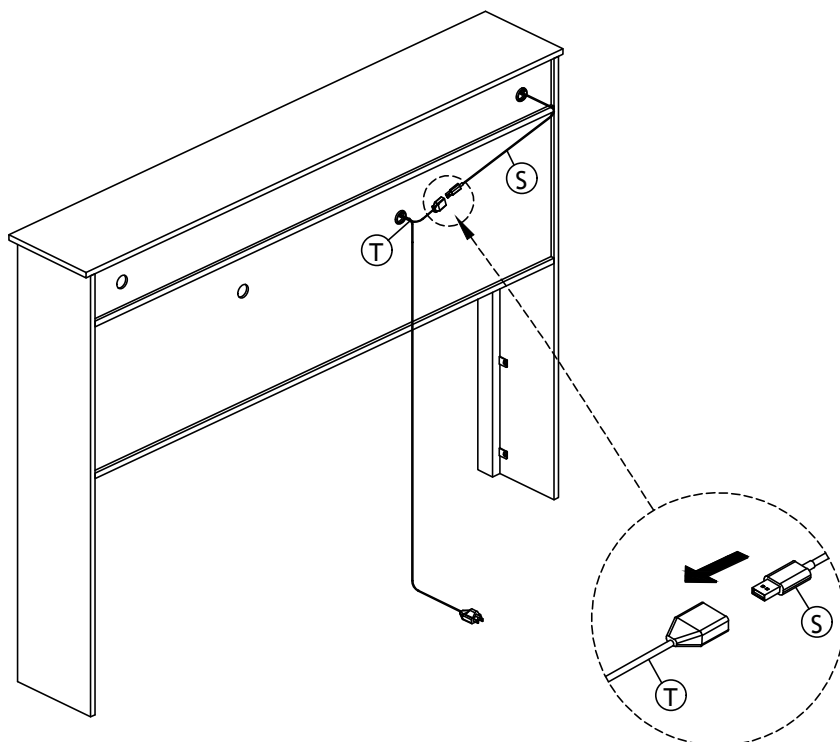

Connect LED strip usb and socket.

STEP 16

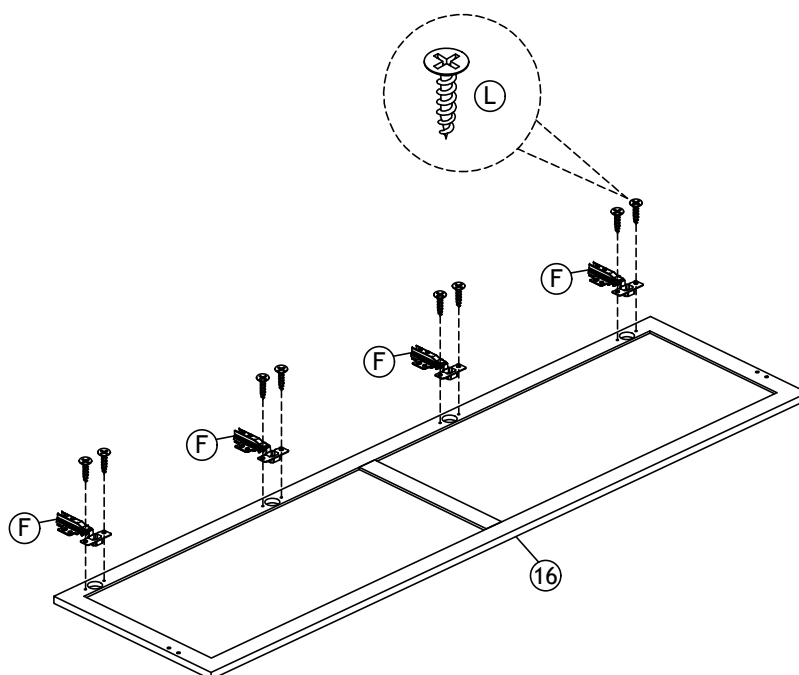
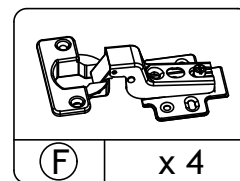
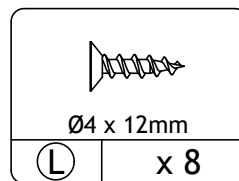
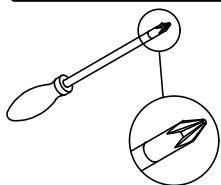

STEP 17

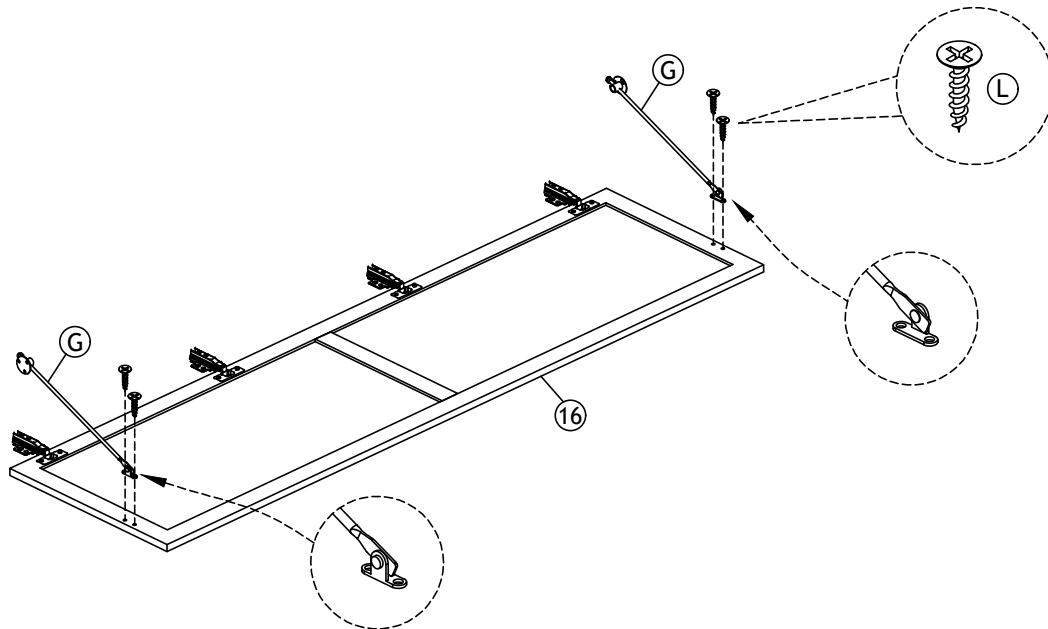
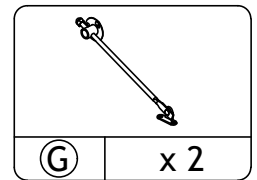
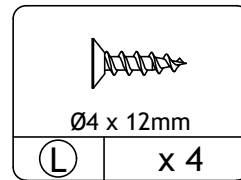
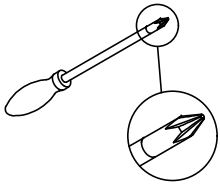

STEP 18

You will use this step in the next step.

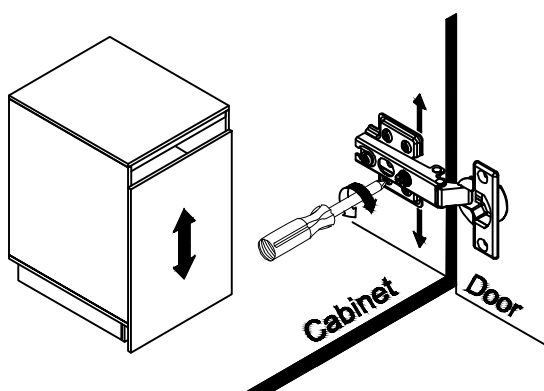
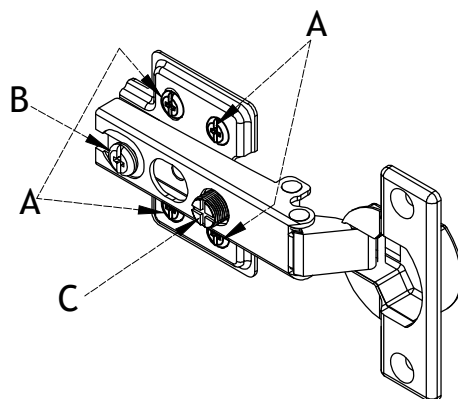

To adjust the vertical height.

Loosen the four screws "A" on both hinges. Two of them are usually in slotted holes which allows you to adjust up or down by a few mm. Then tighten back up.

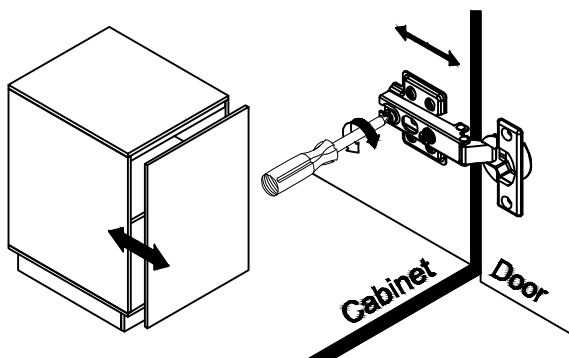

To adjust depth.

Loosen screw "B" and adjust door, if the door cannot be adjusted, please loosen screw "C", then try again. Tighten screw "B" and "C"

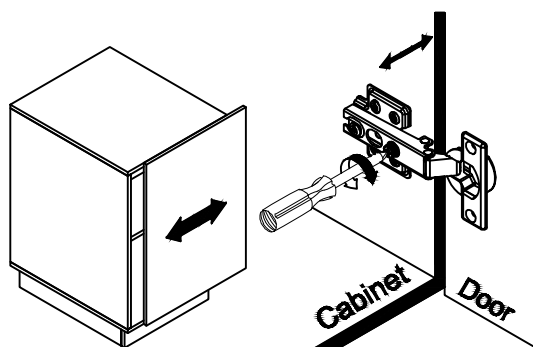

To adjust side ways.

Turning the screw "C" on BOTH hinges on each door.

STEP 19

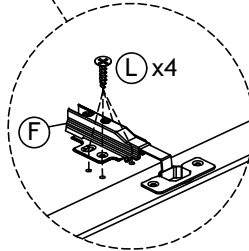
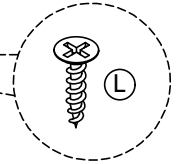
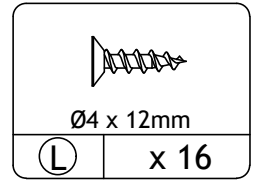
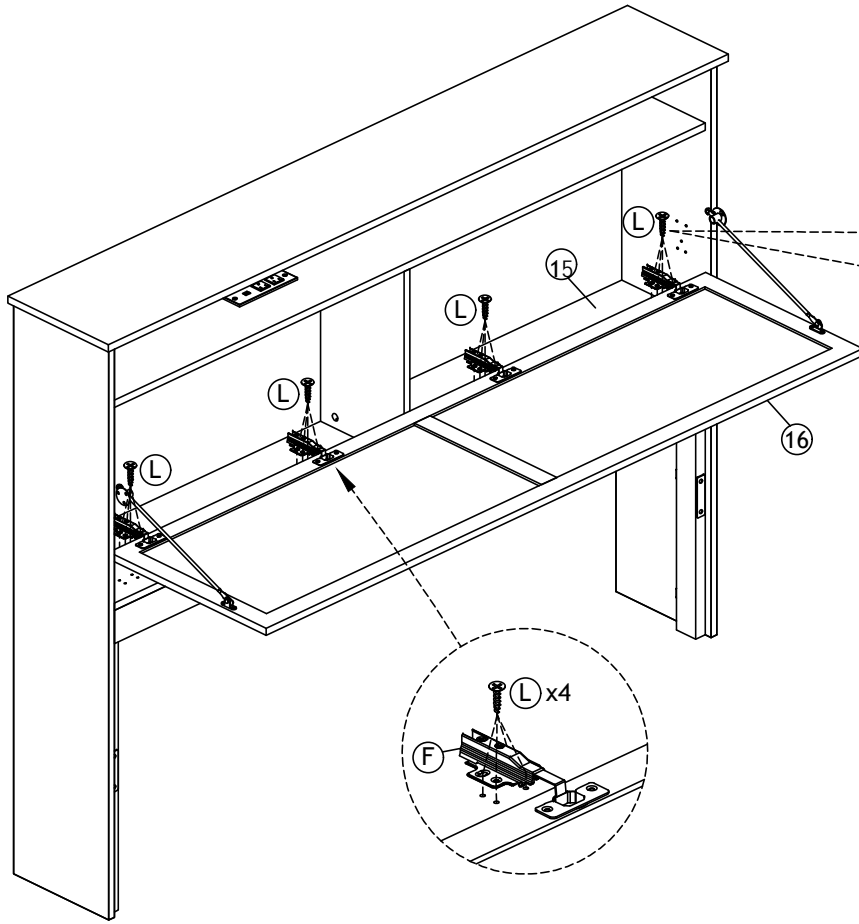
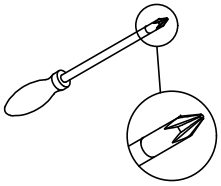

STEP 20

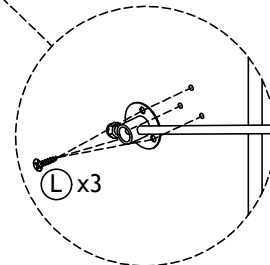
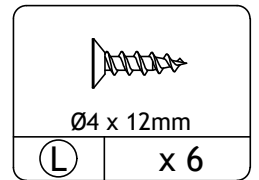
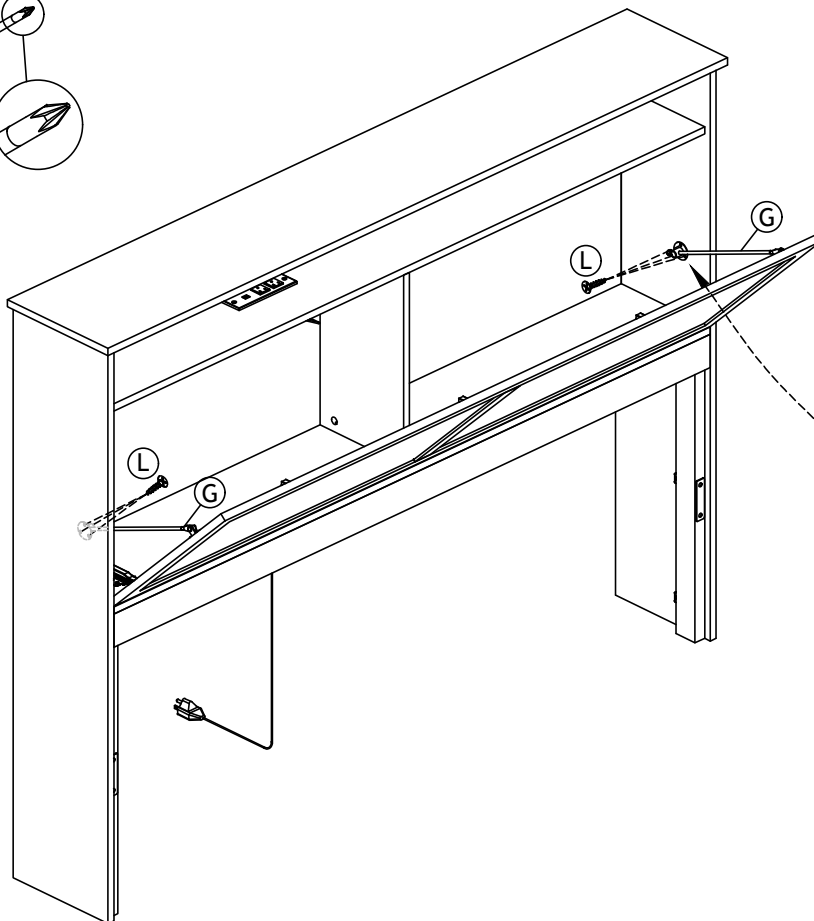
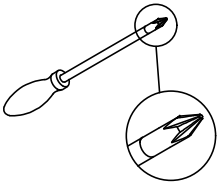

STEP 21

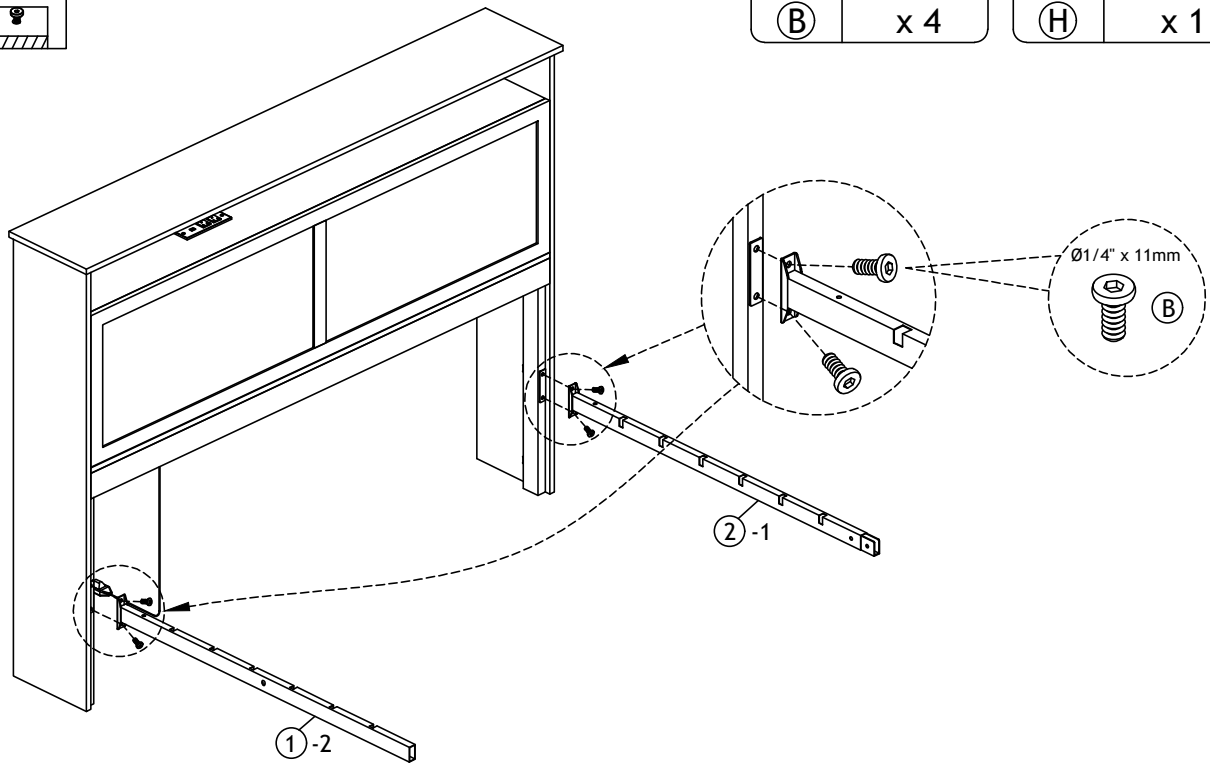
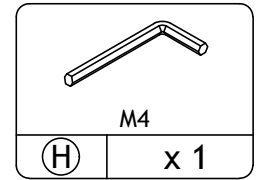
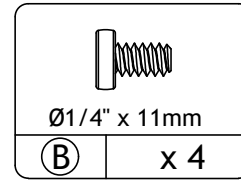
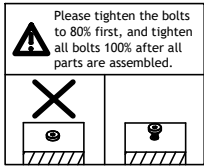

STEP 22

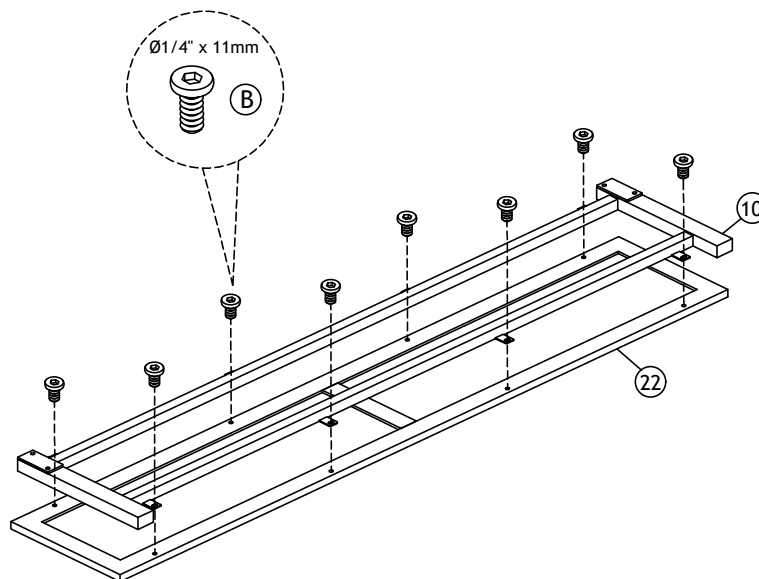
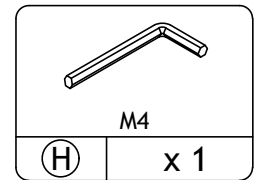
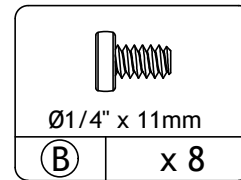
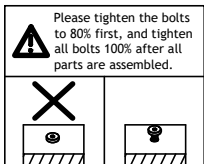

STEP 23

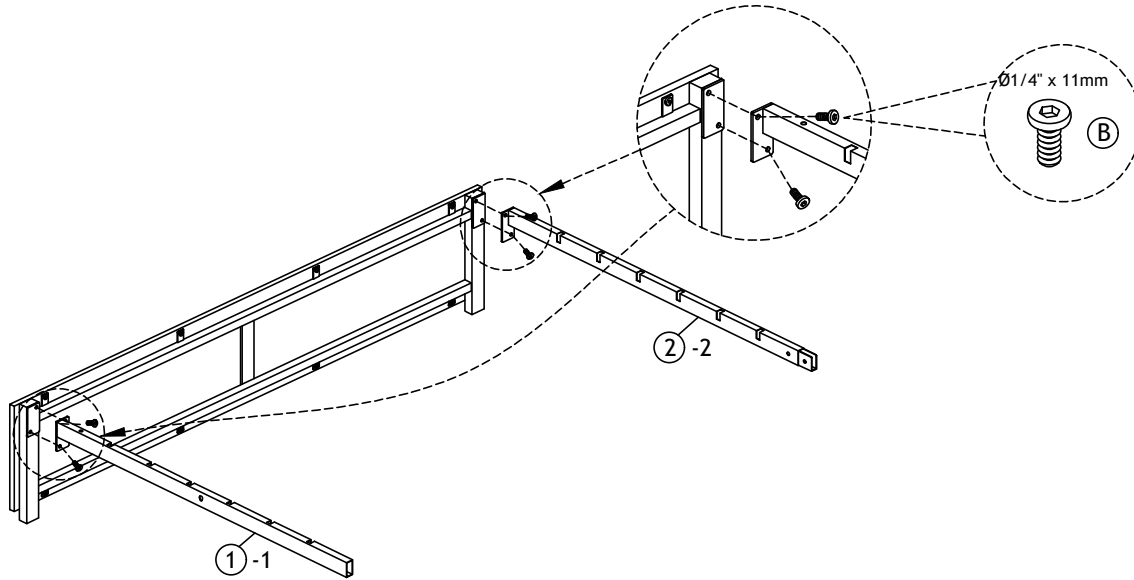
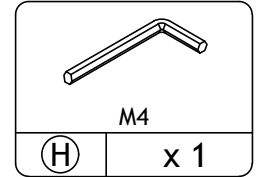
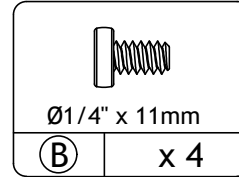
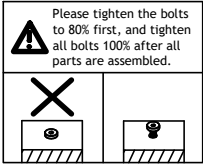

STEP 24

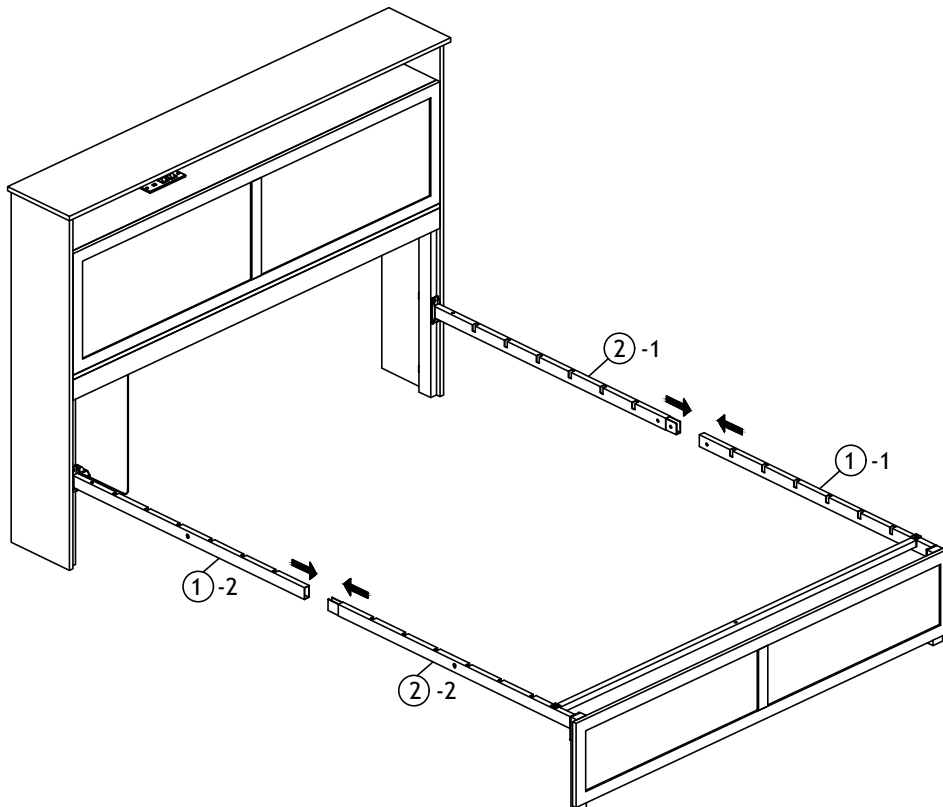

STEP 25

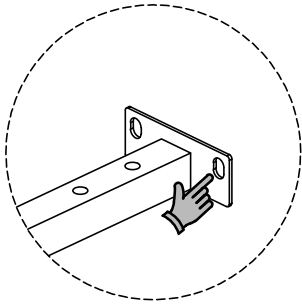
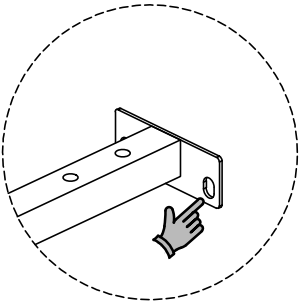
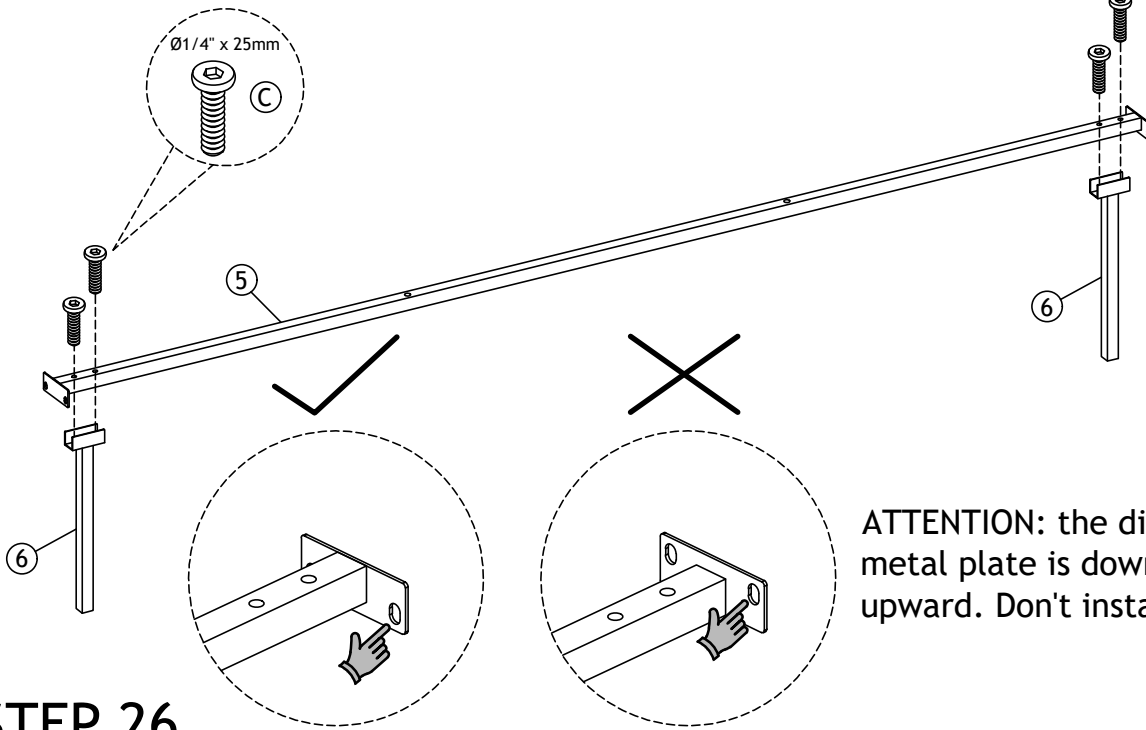
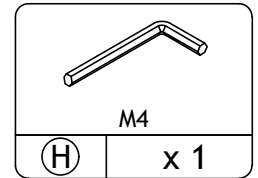
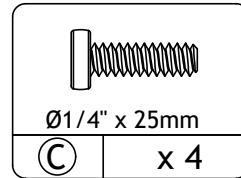
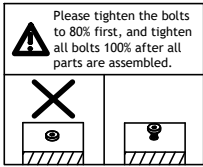

ATTENTION: the direction of the metal plate is downward and not upward. Don't install it wrongly.

STEP 26

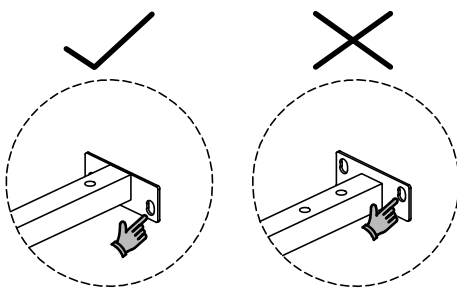
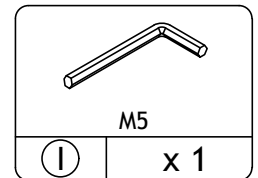
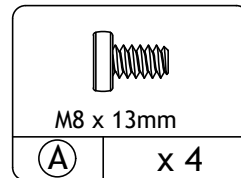
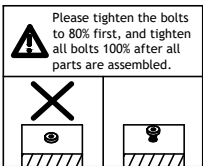

ATTENTION: the direction of the metal plate is downward and not upward. Don't install it wrongly.

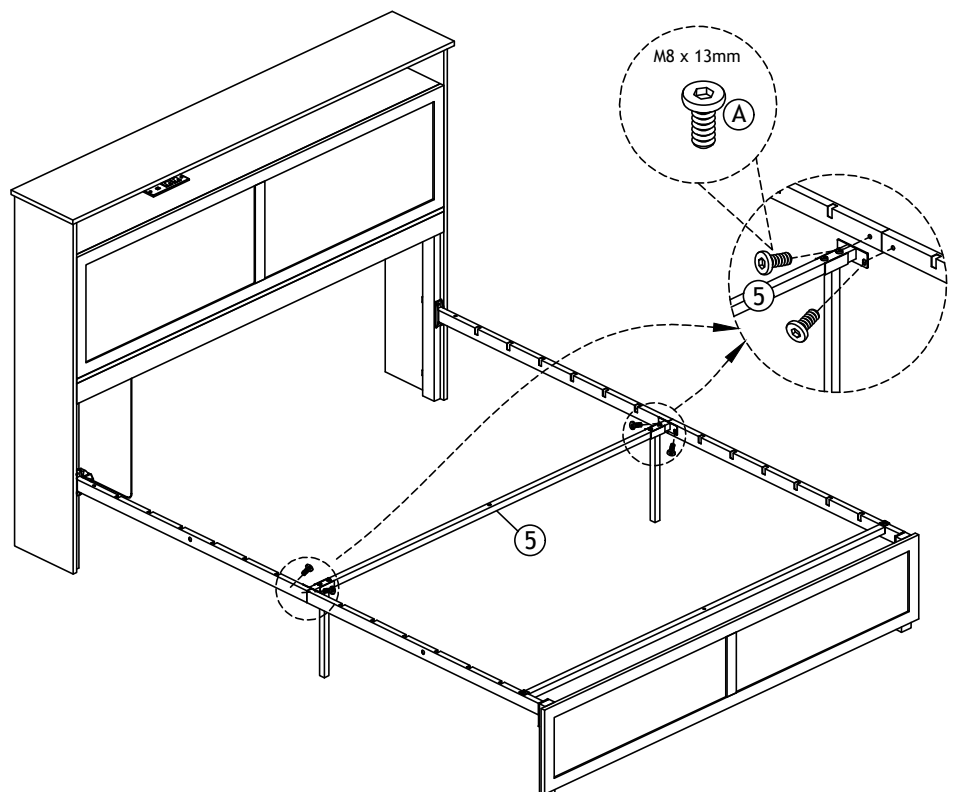

STEP 27

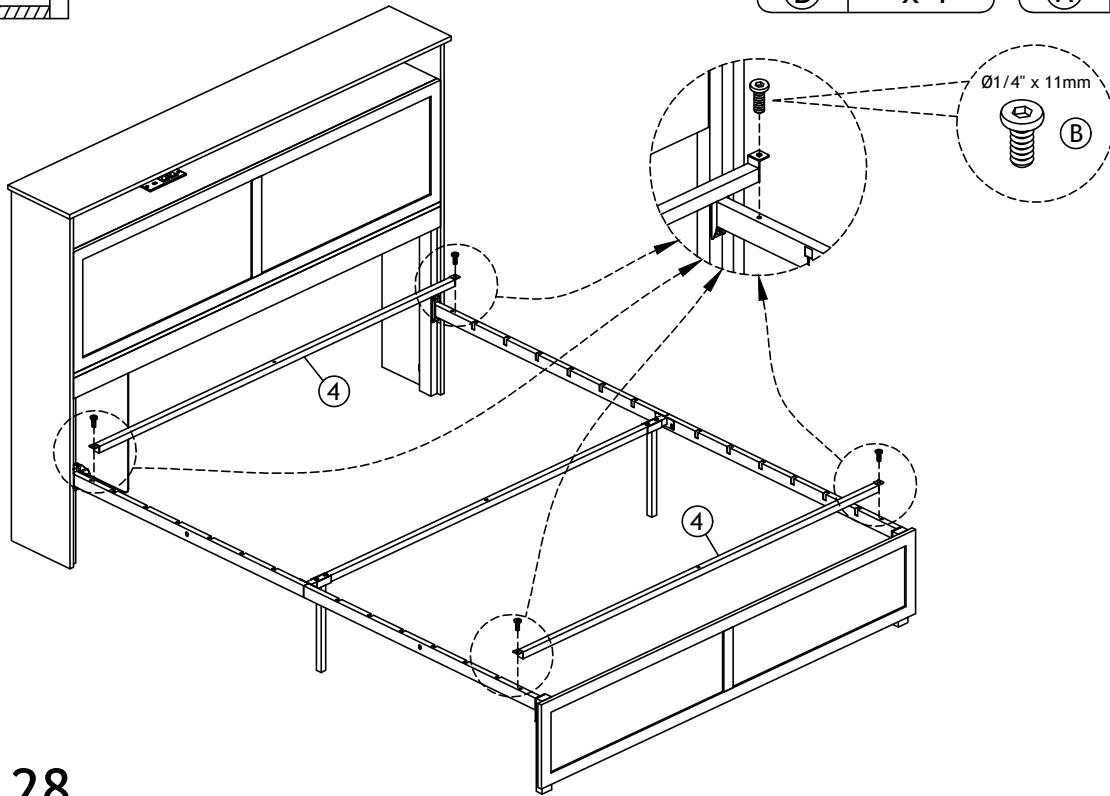
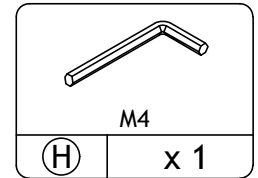
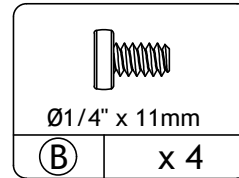
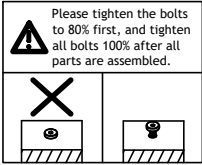

STEP 28

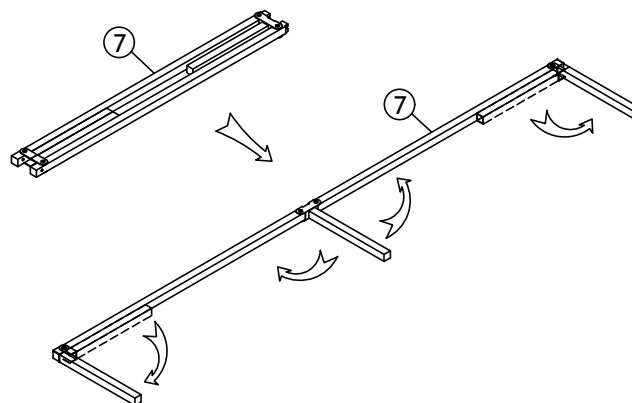

Expand the folded portion

STEP 29

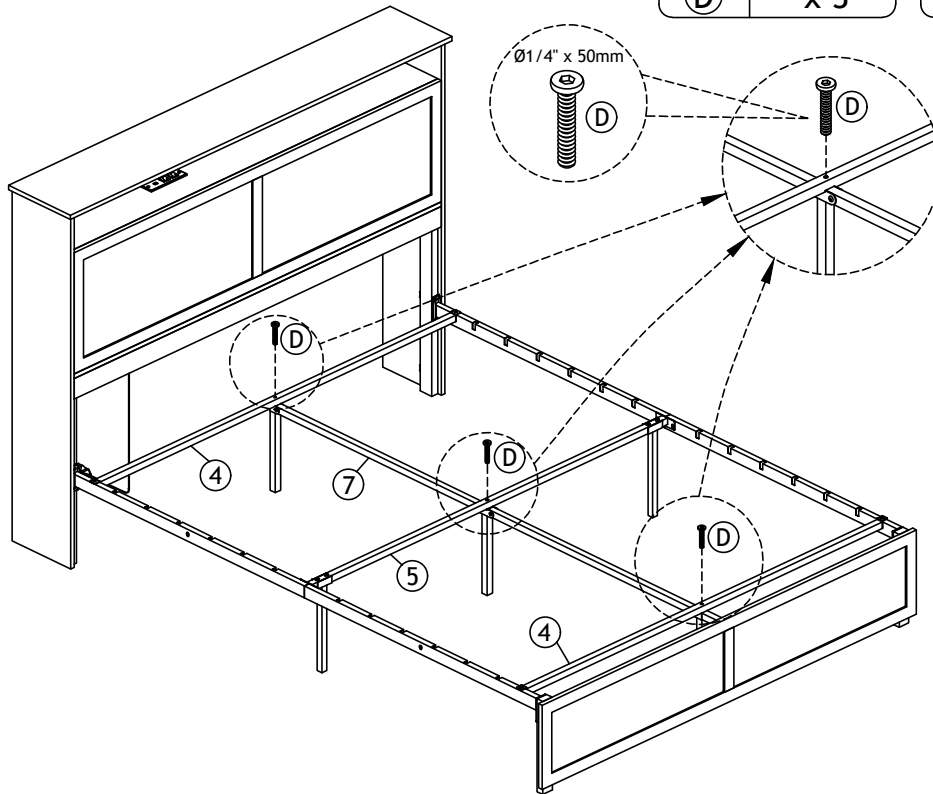
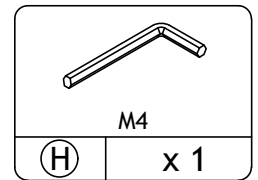
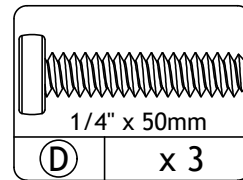
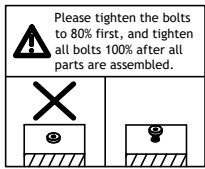

STEP 30

You will use this step in the next step.

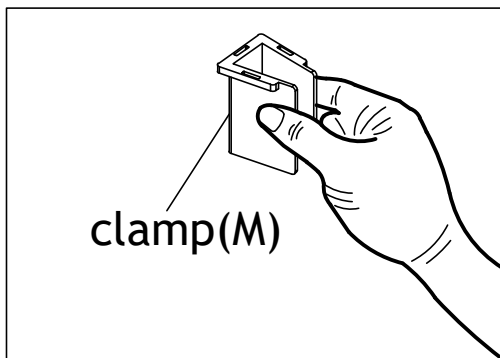

1. Squeeze the clamp (M) tightly.

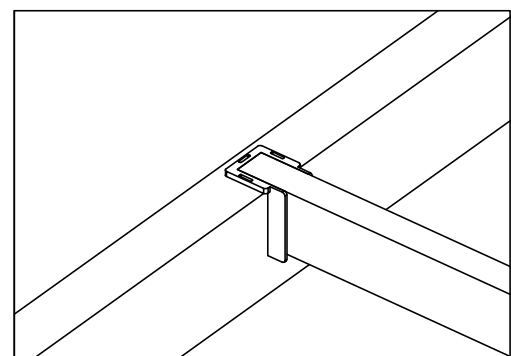
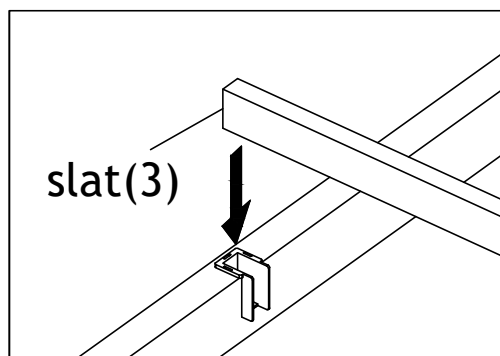
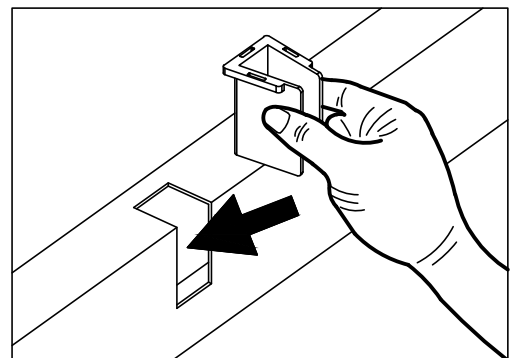

STEP 31

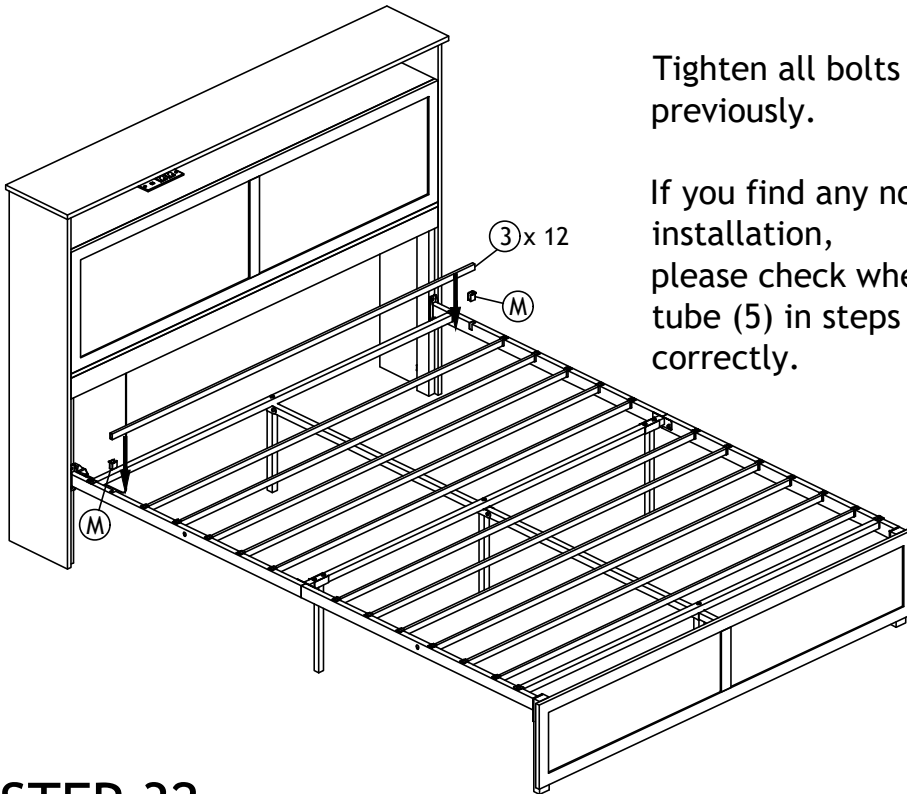
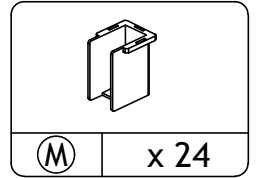

Tighten all bolts that were not tightened previously.

If you find any noise from the bed frame after installation, please check whether the direction of the tube (5) in steps 25 and 26 is installed correctly.

STEP 32

Expand the drawer frame

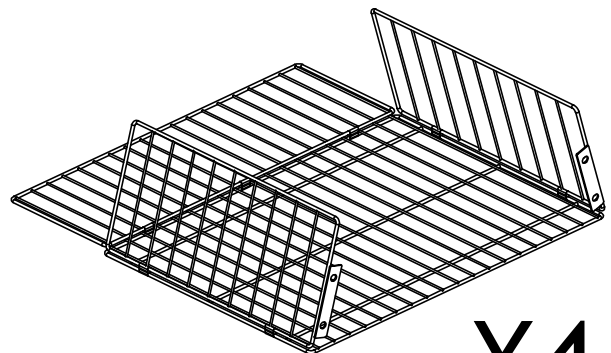
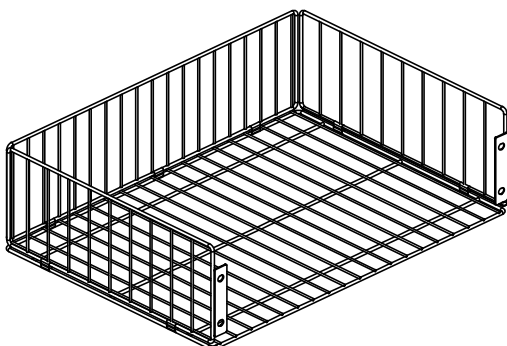
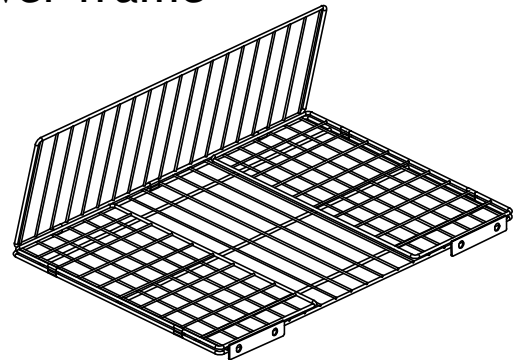
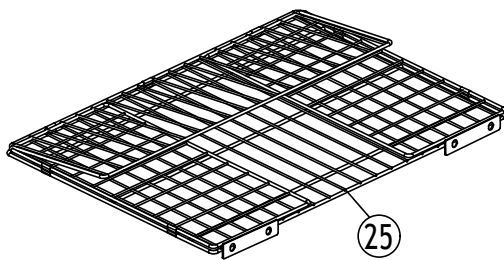

X4

STEP 33

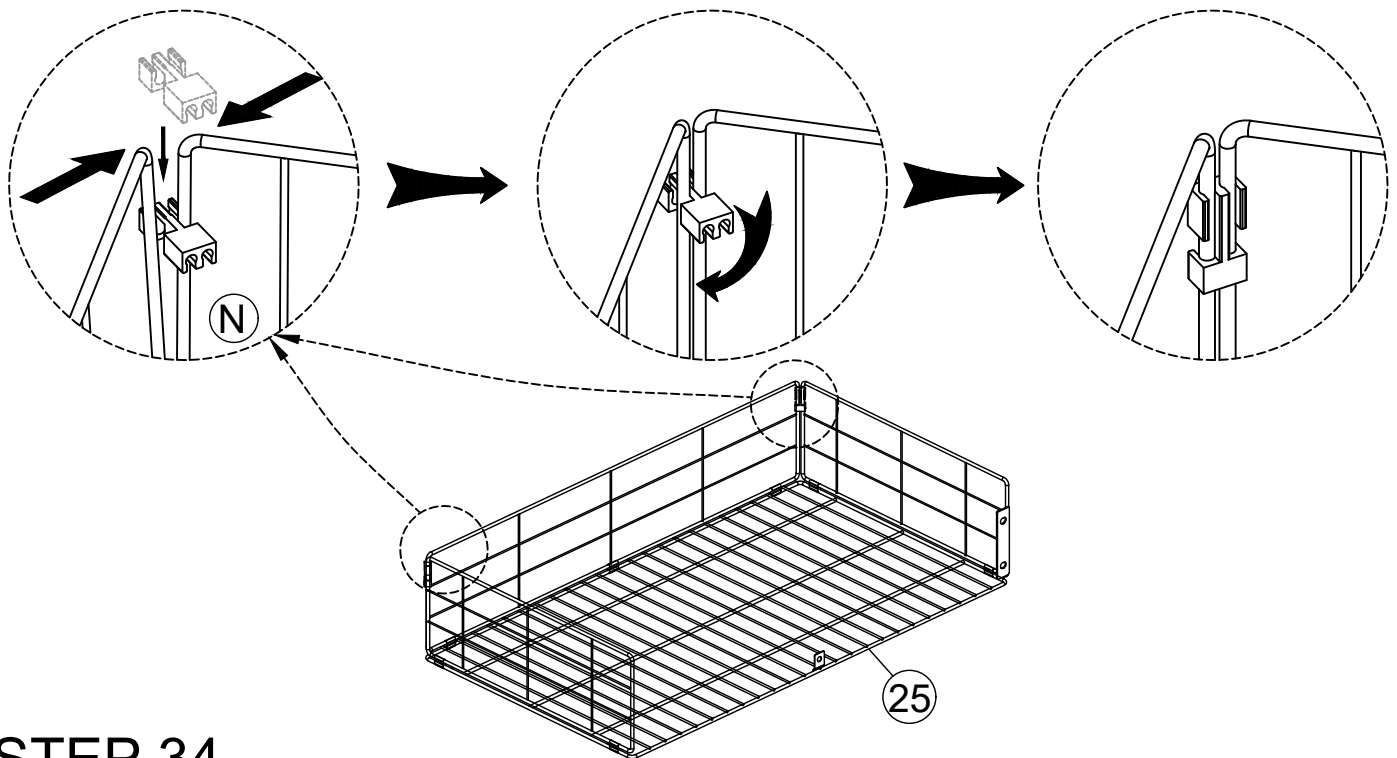
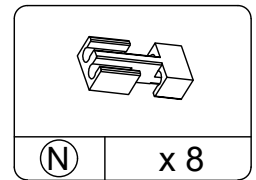

STEP 34

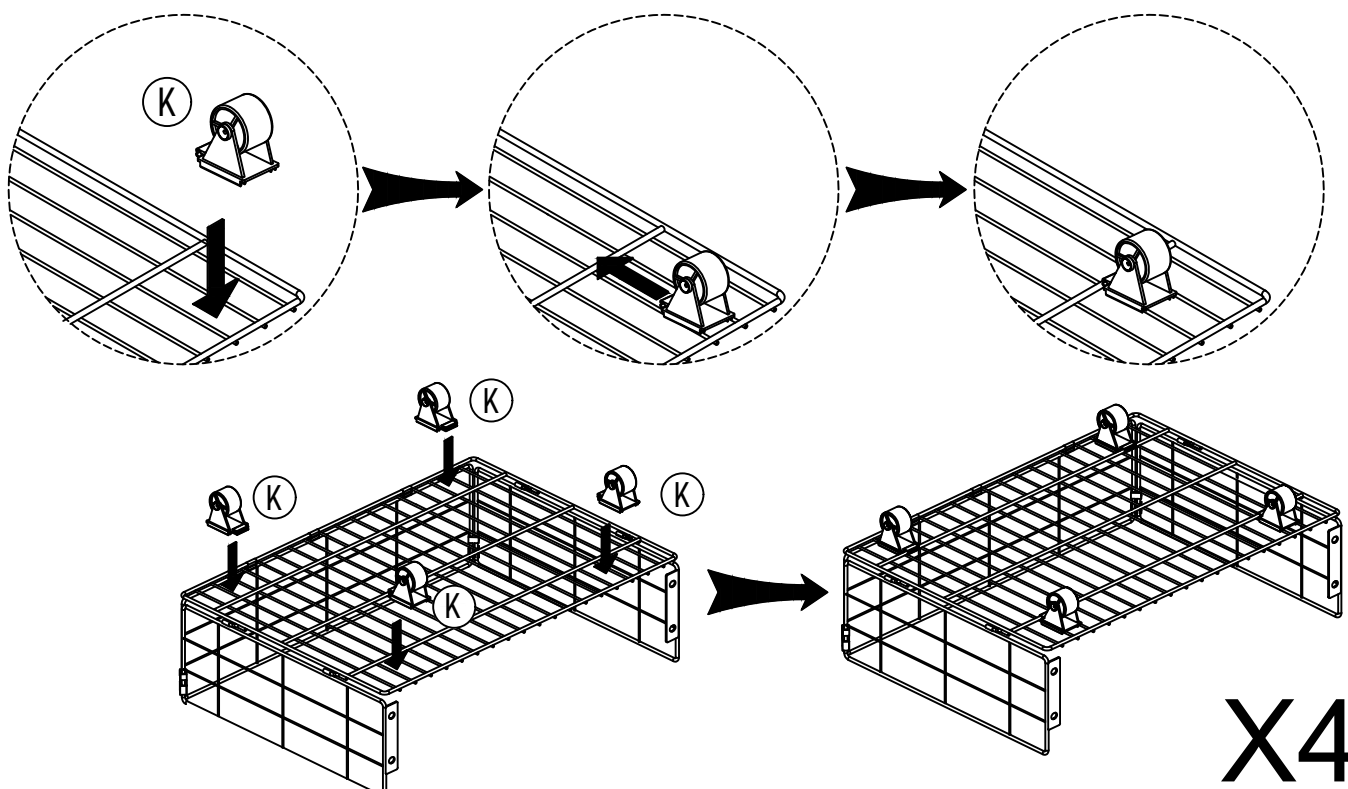
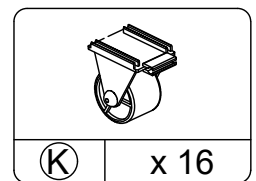

STEP 35

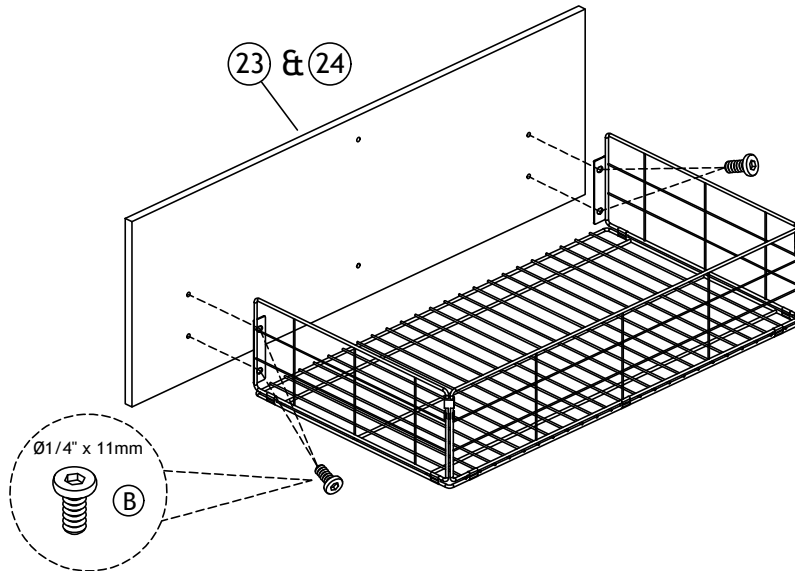
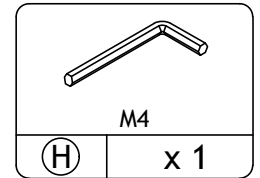
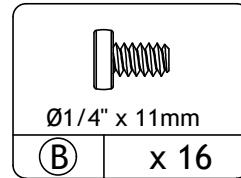
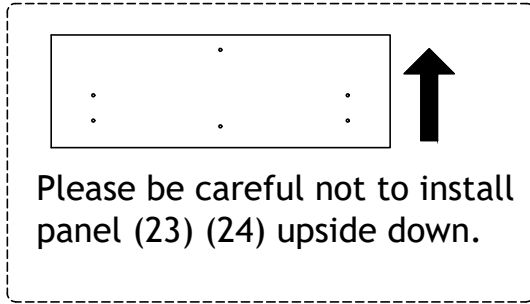
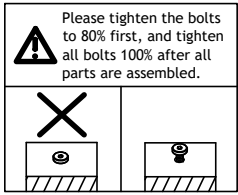

STEP 36

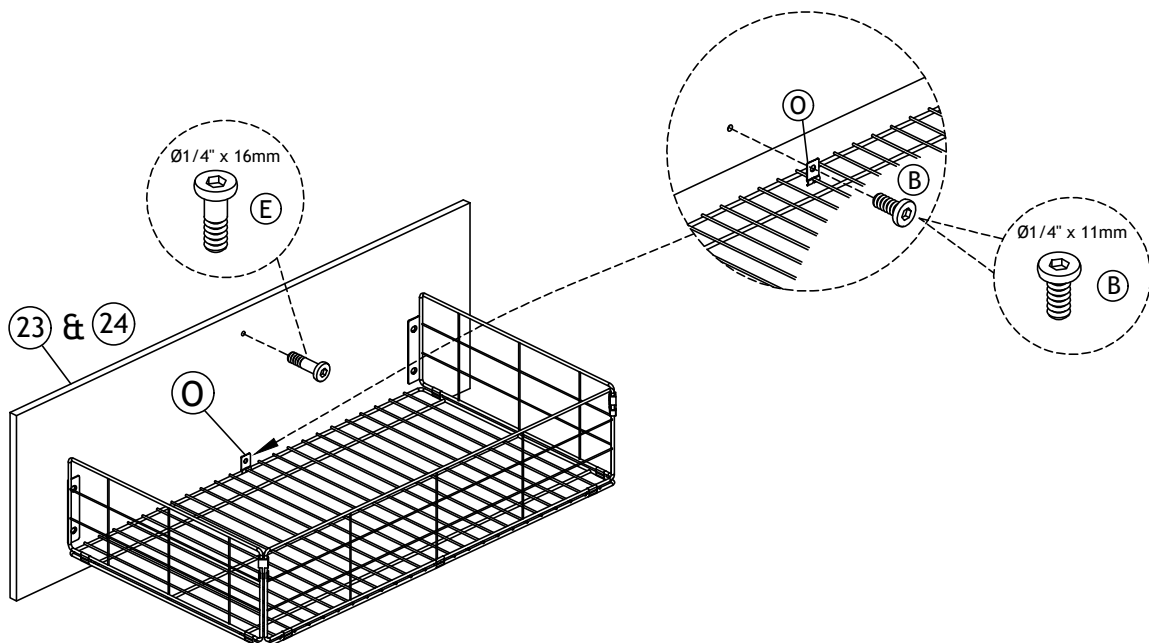
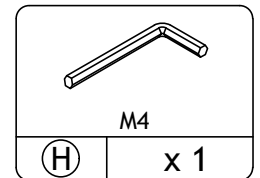
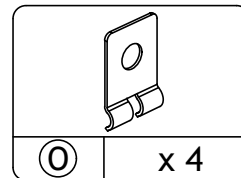
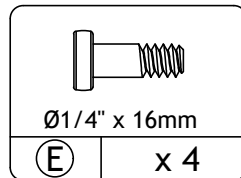
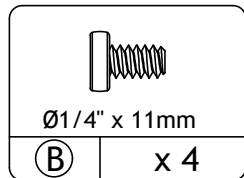

STEP 37

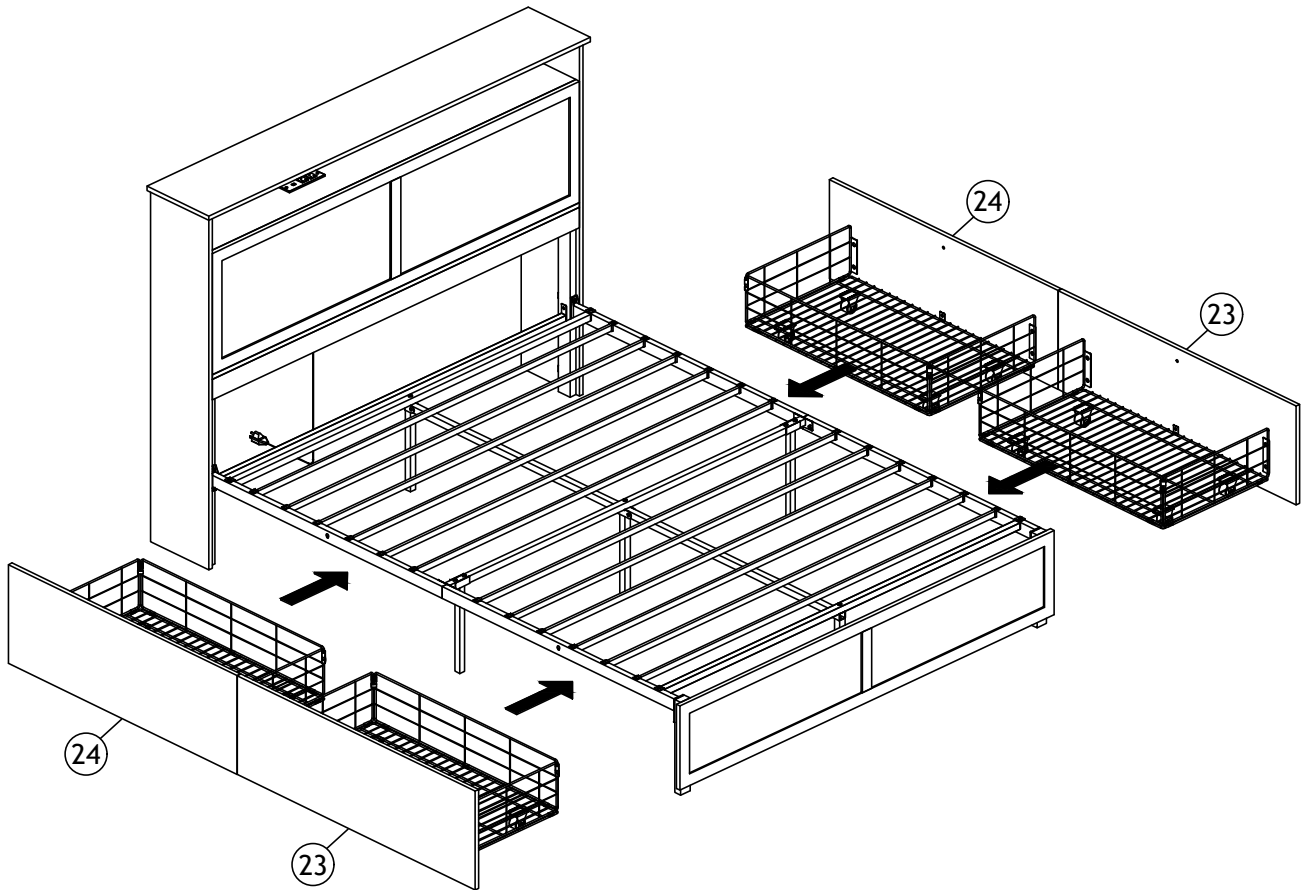

STEP 38

When pushing into the drawer, Lift the drawer gently, align the screw with the gourd hole and push in.
when pulling out the drawer, Lift the drawer gently, align the screw with the gourd hole, and then pull it out.

