

x1

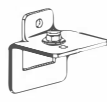

x5



x2

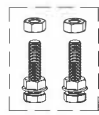

x1



x2



x2



x3

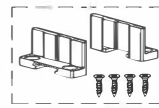

x1

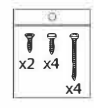

x1



40
KG

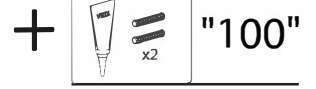

"100"

1

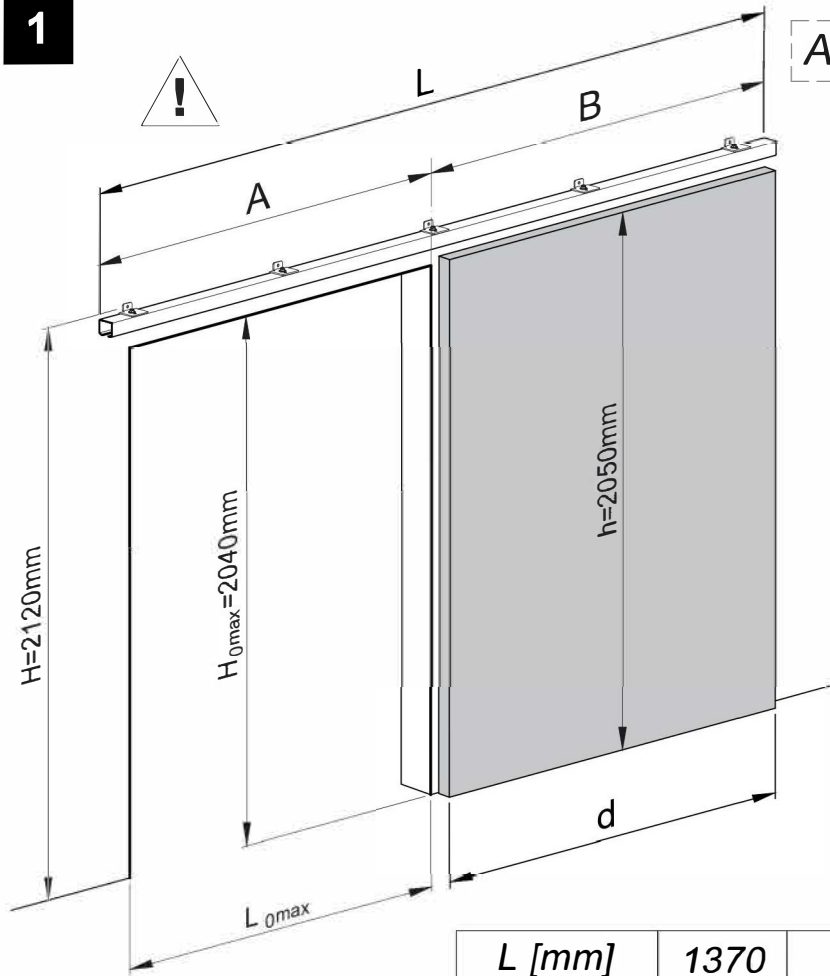

A=B

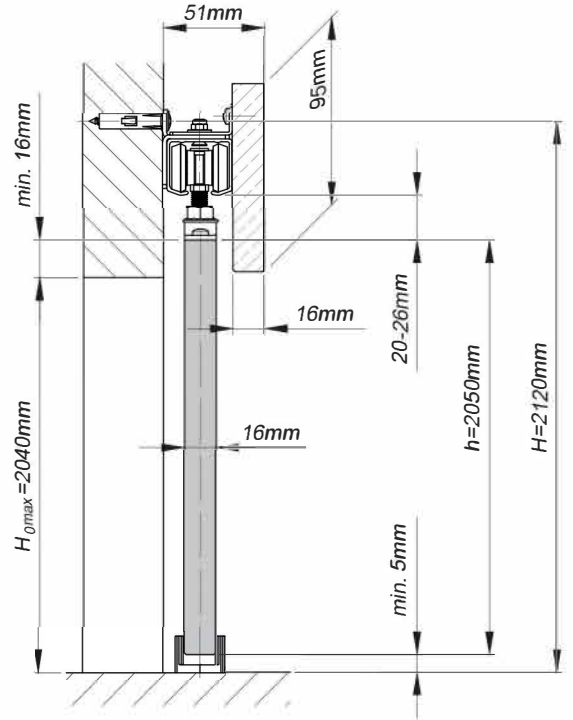

L [mm]	1370	2000			
d [mm]	660 "60"	760 "70"	860 "80"	960 "90"	1060 "100"
L _{0max} [mm]	600	700	800	900	1000

2

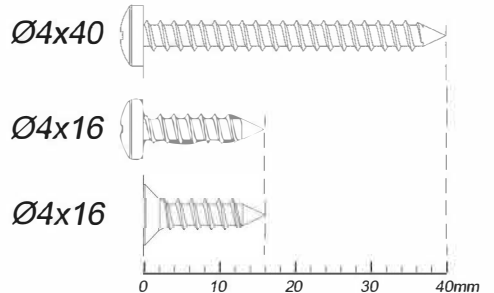
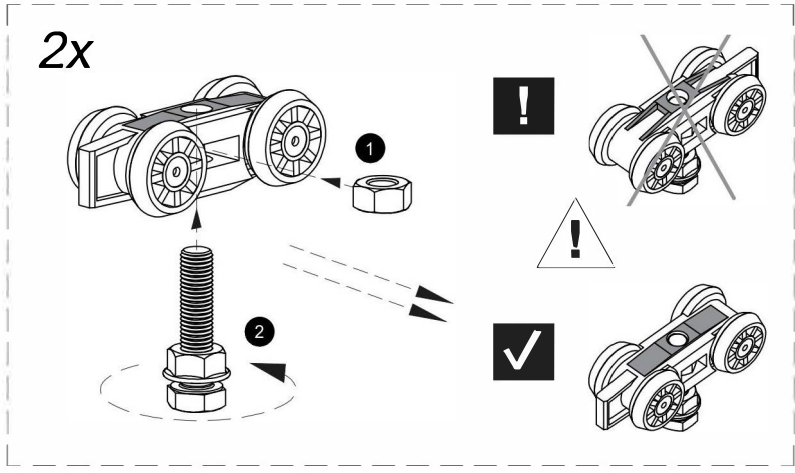

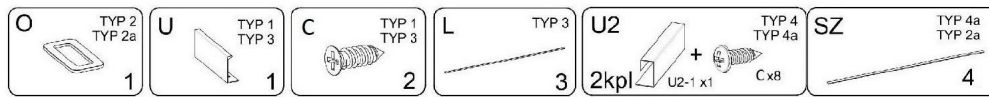
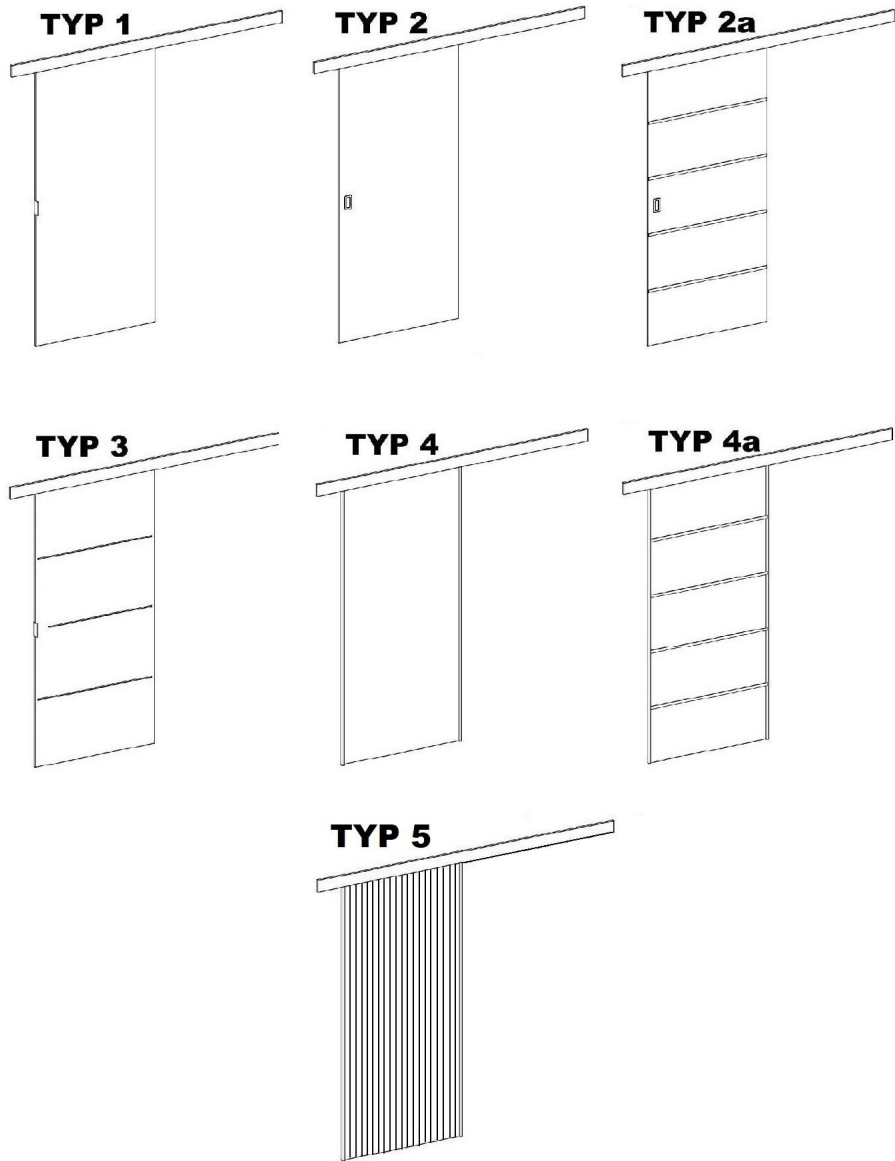

TYP 1

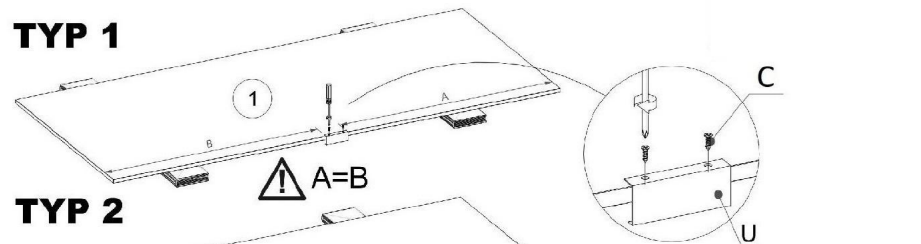

TYP 2

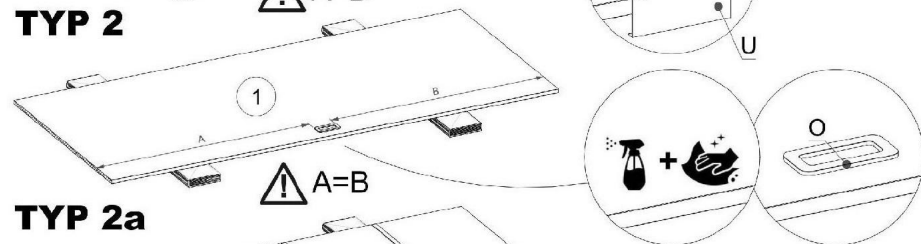

TYP 2a

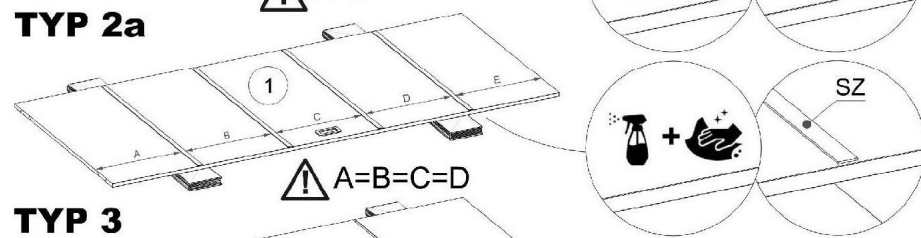

TYP 3

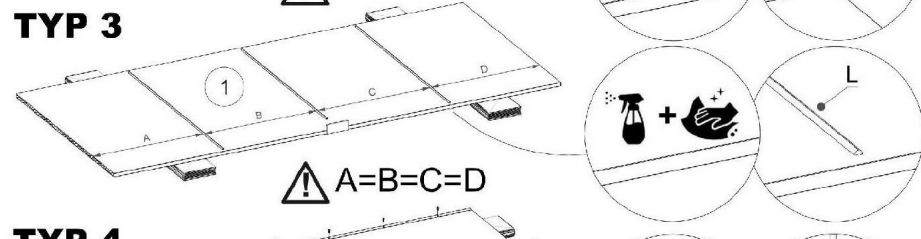

TYP 4

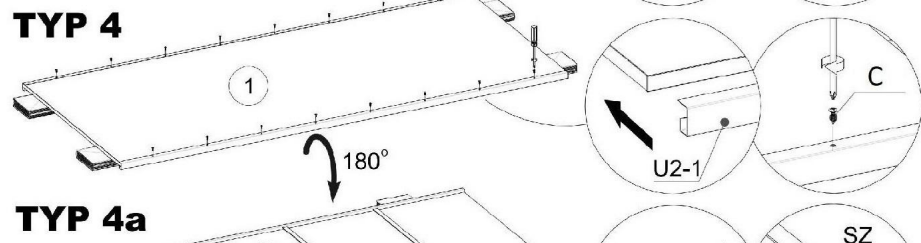

TYP 4a

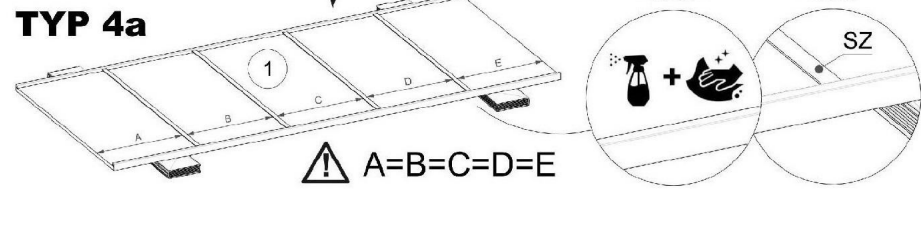

3b

TYP 5



~25 min

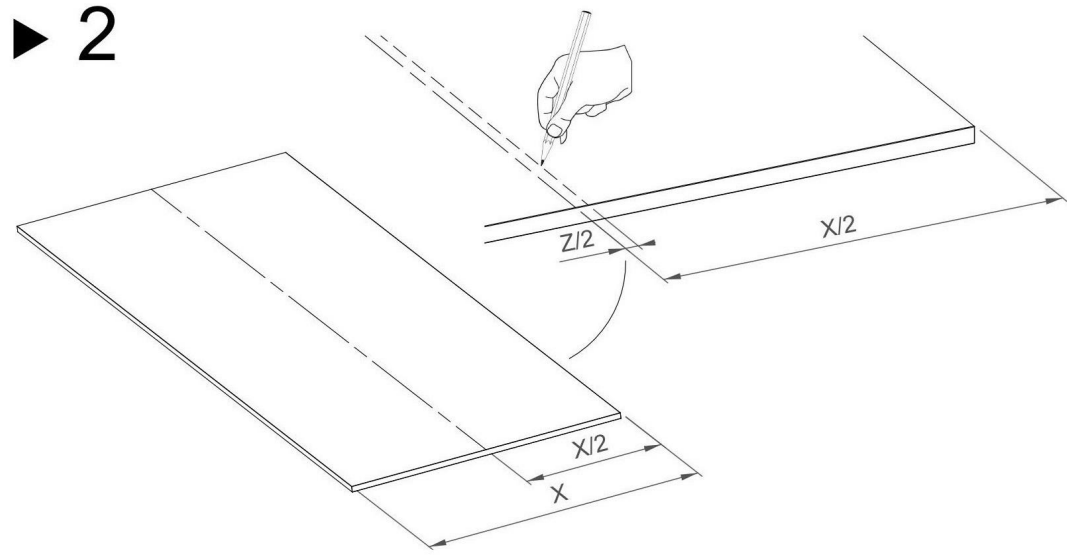
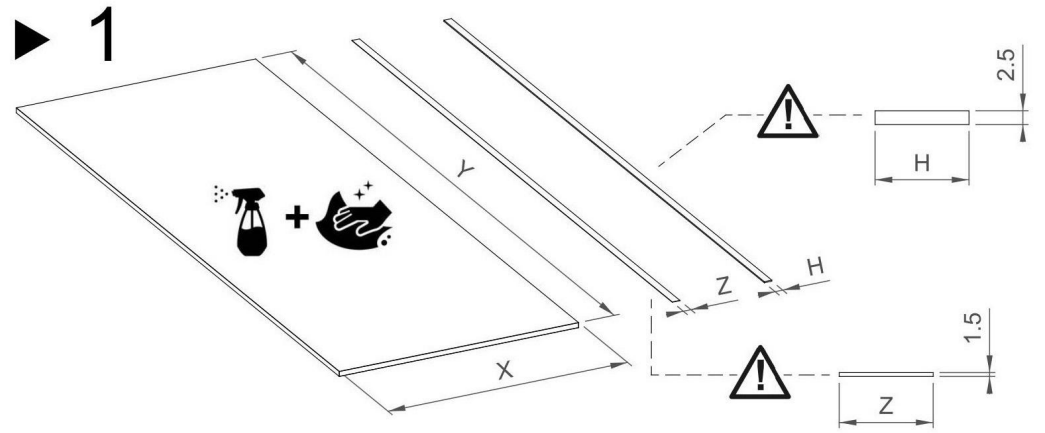
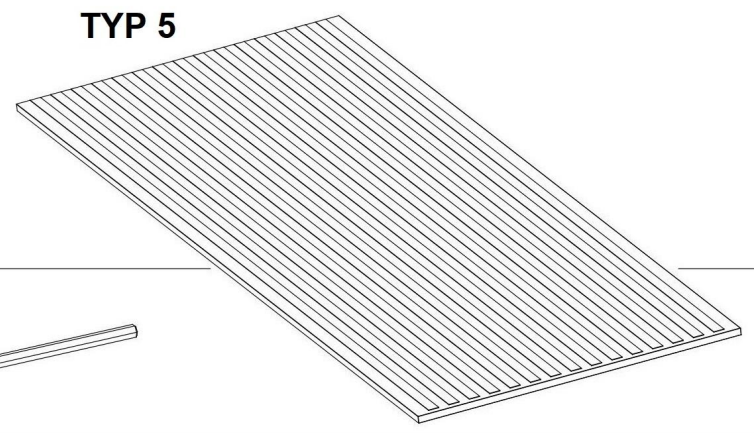
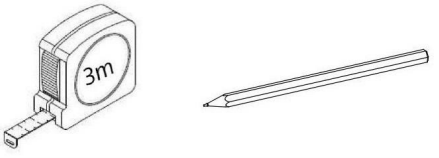

▶ 3

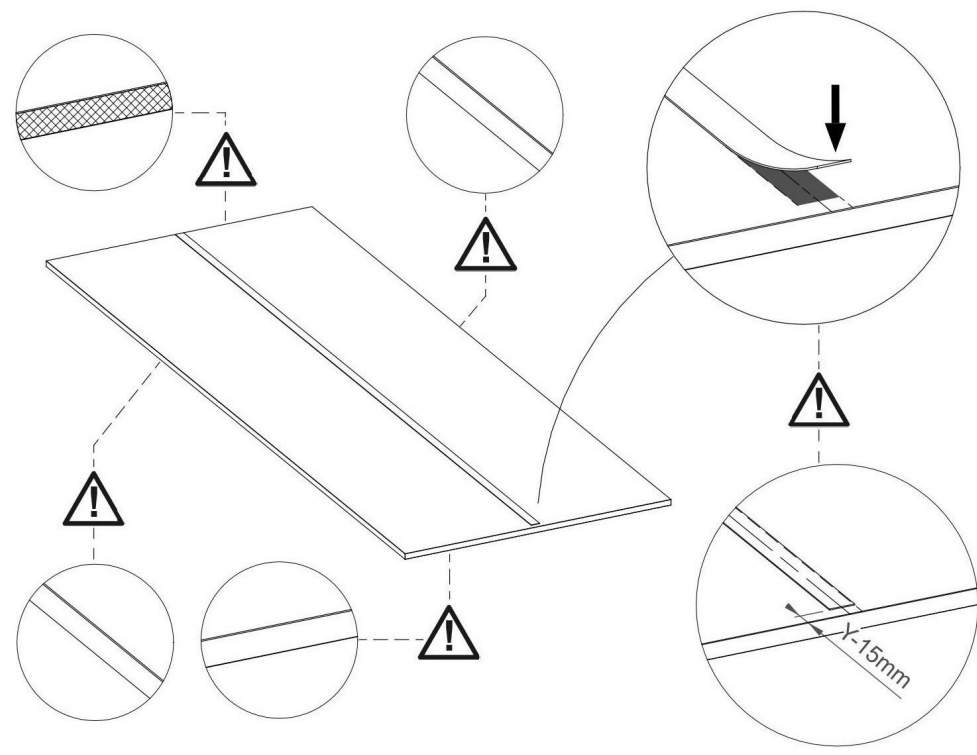

▶ 4

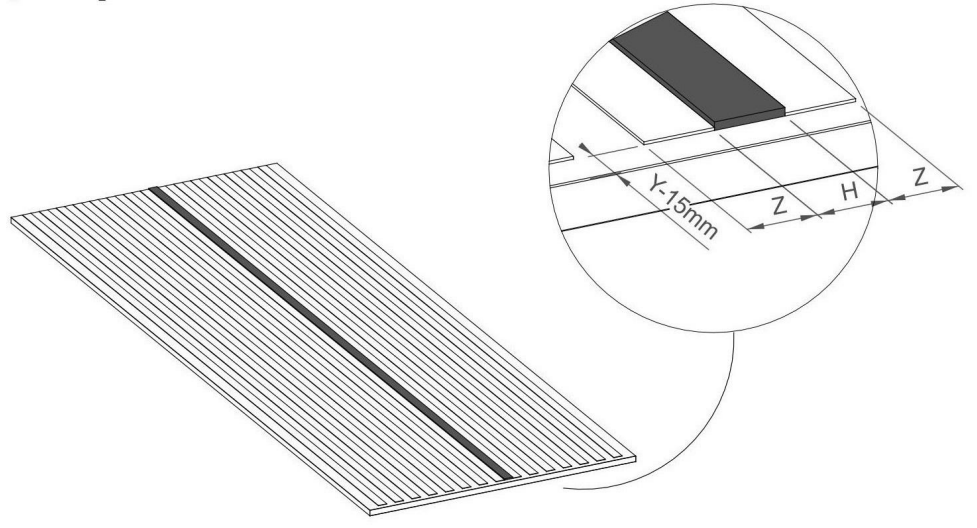

4a

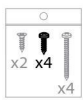

"60"

1520mm

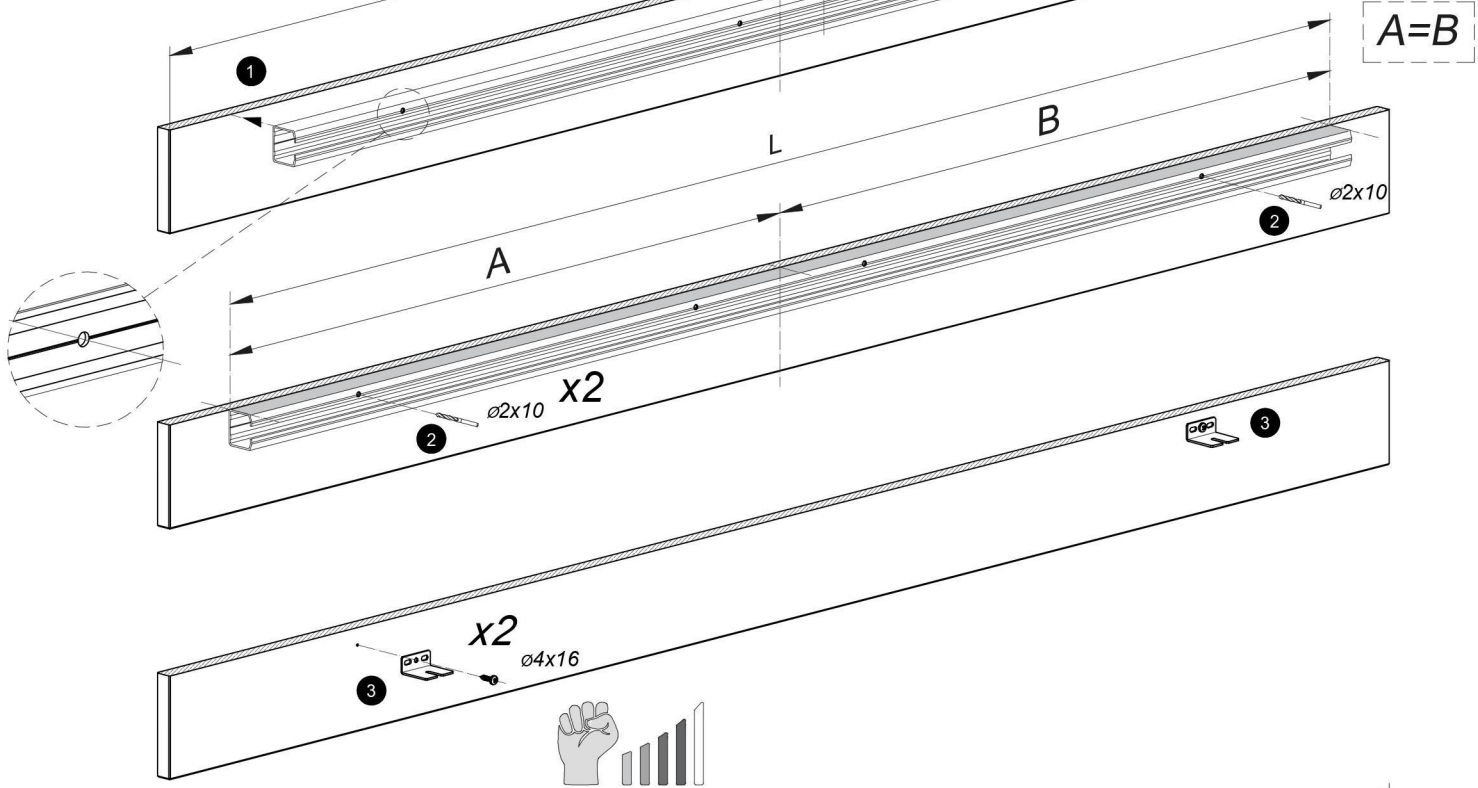

4b

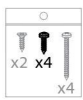

"70" / "80" / "90"

2050mm

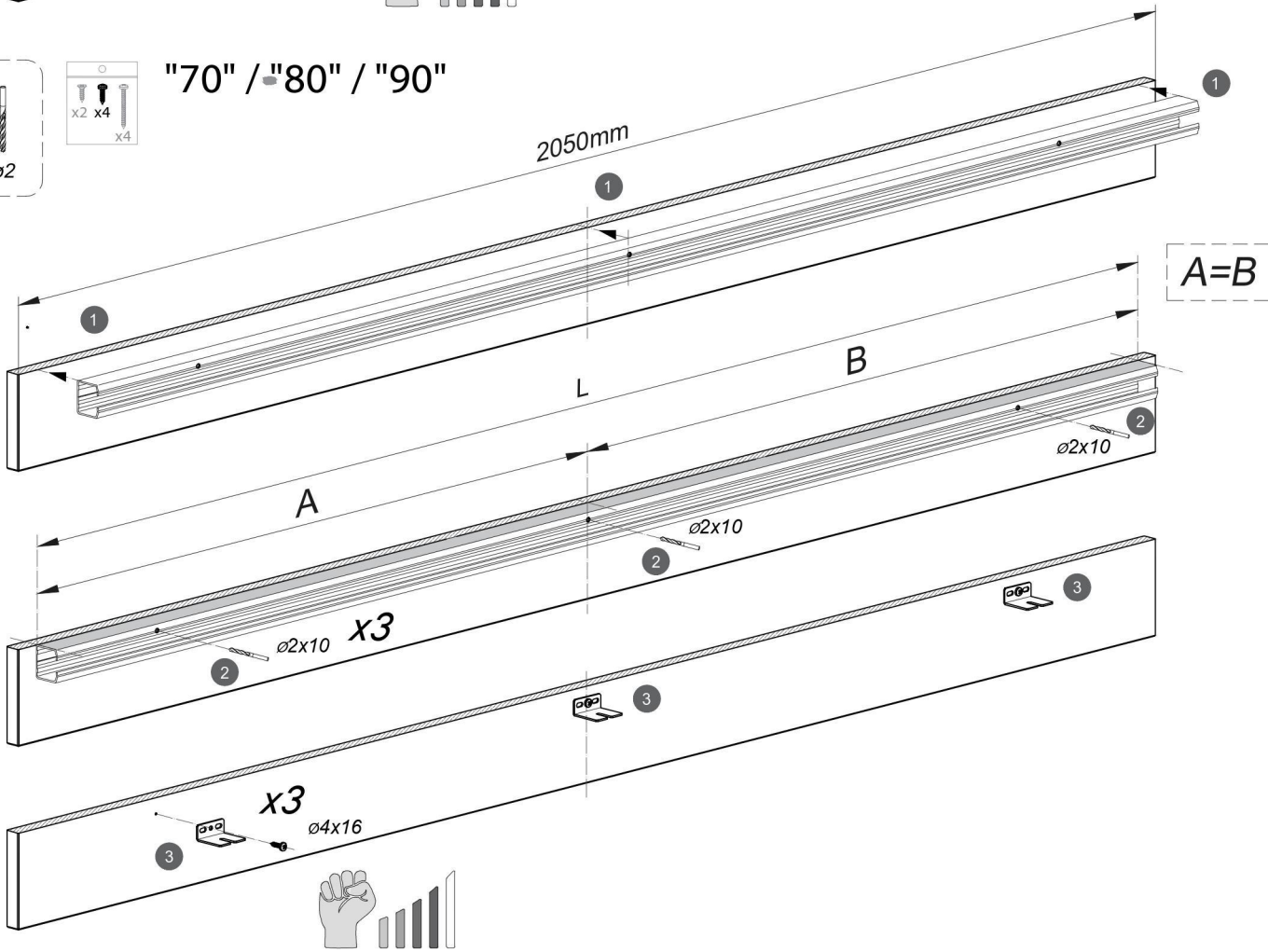

4c

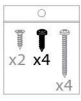

"100"



1100mm

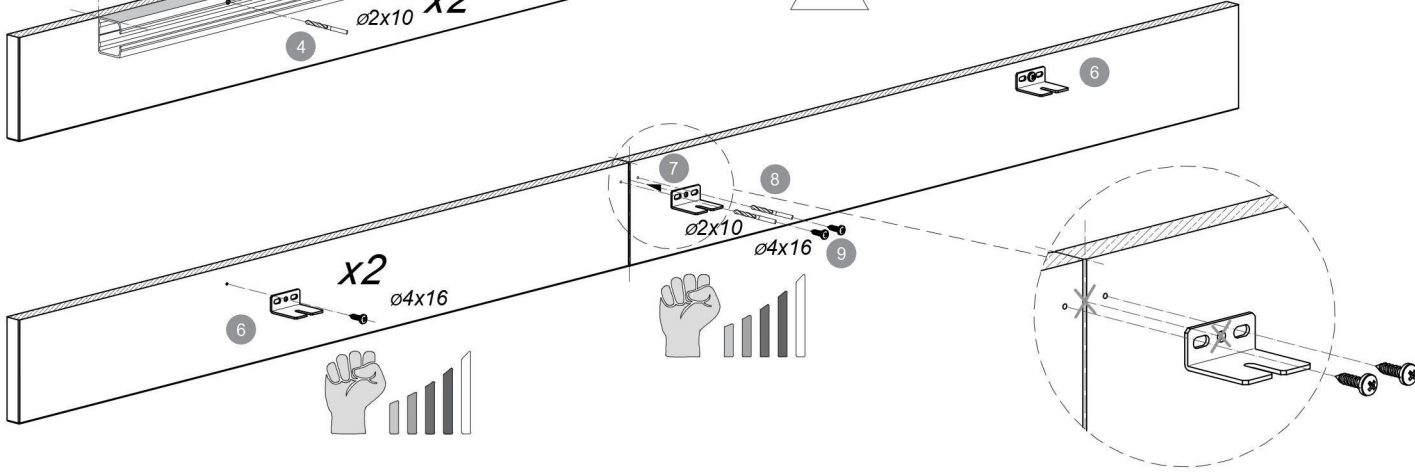
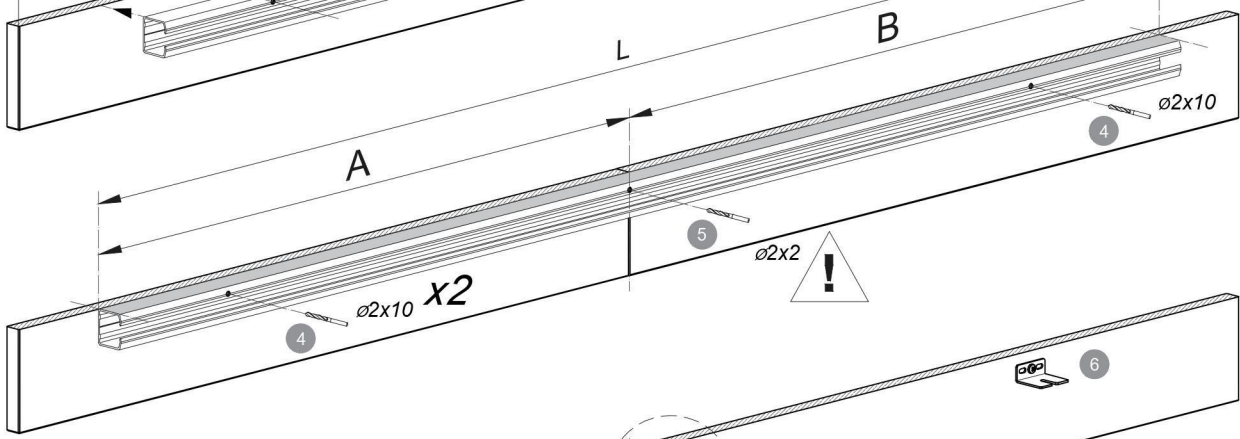
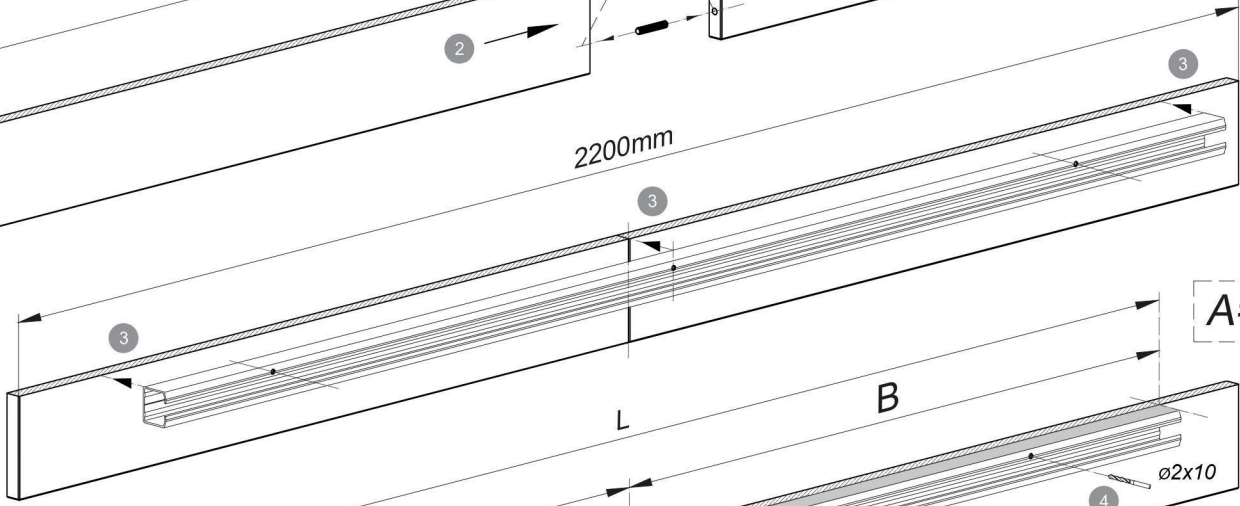
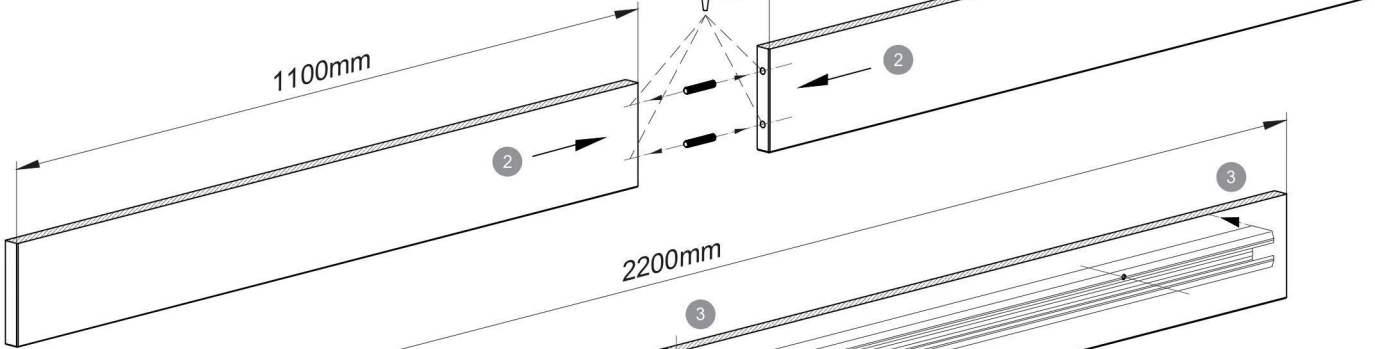

5

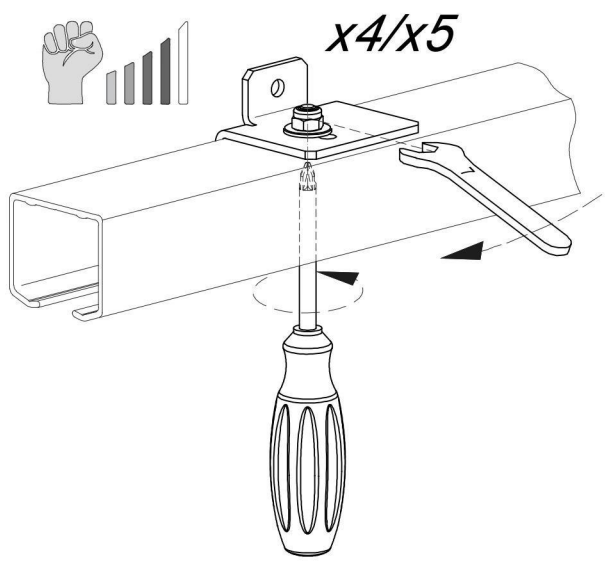
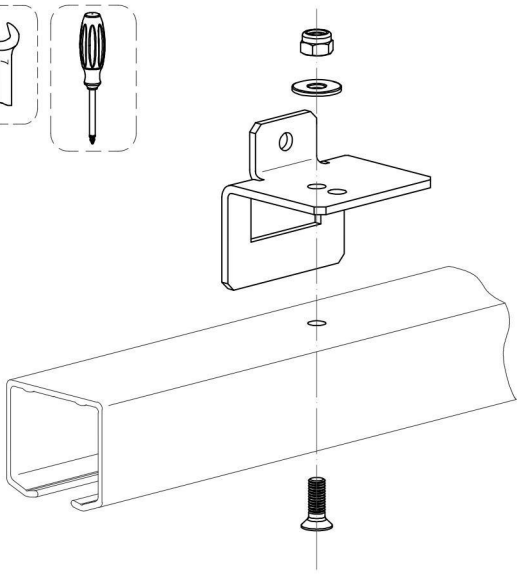
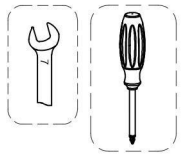

6

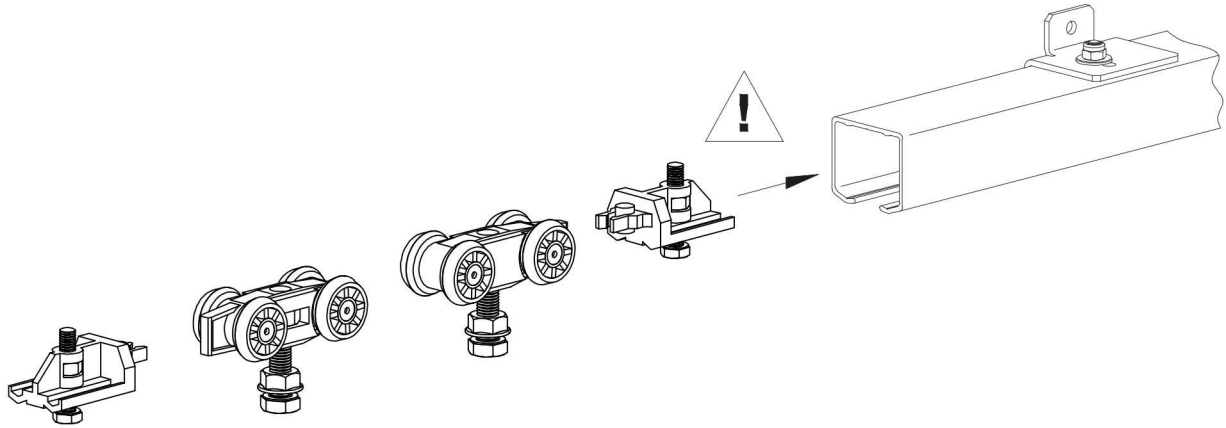

7



x4 - "60"
x5 - "70" / "80" / "90" / "100"

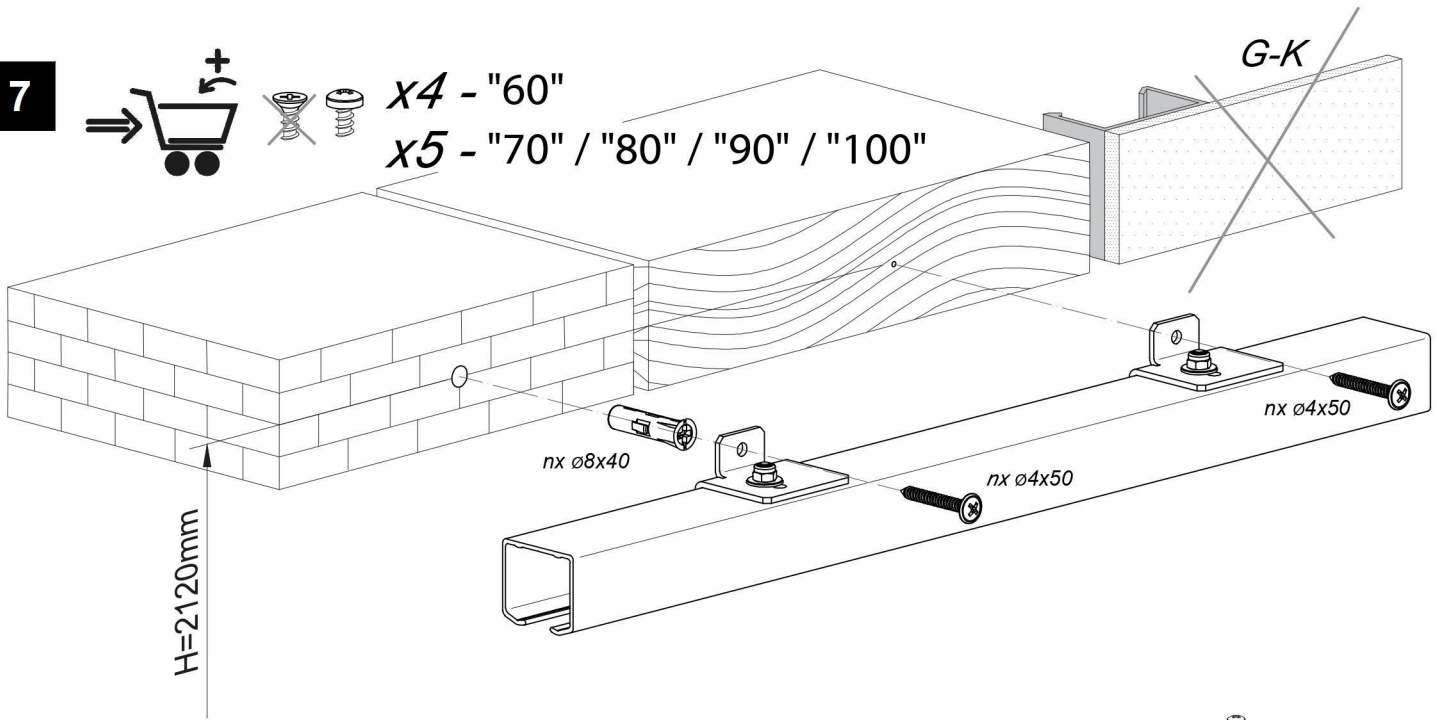

8

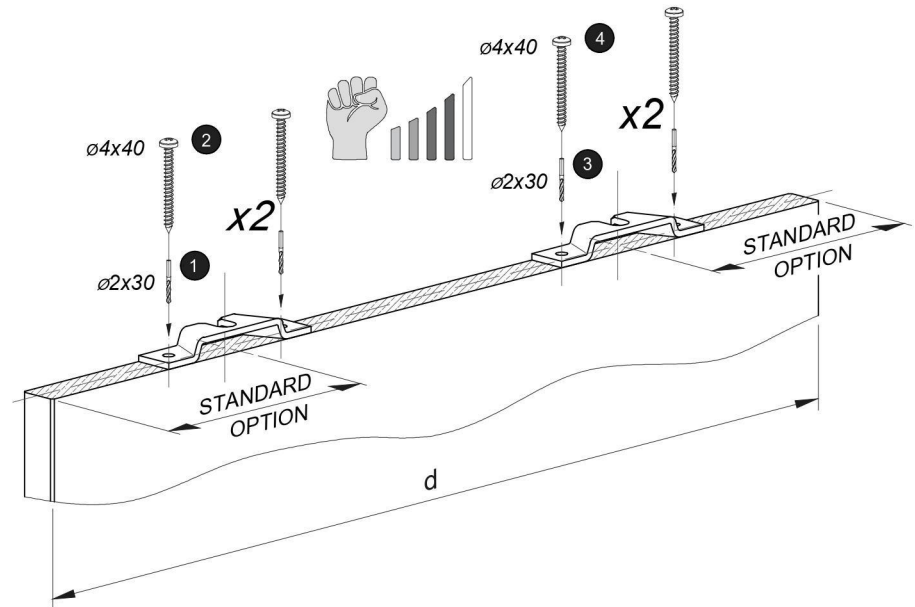
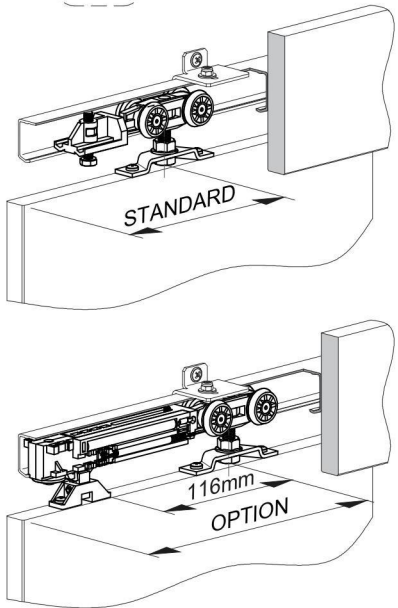
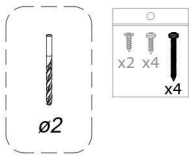

!

	<i>d</i> [mm]	660 "60"	760 "70"	860 "80"	960 "90"	1060 "100"
STANDARD [mm]			100			160
OPTION [mm]			180			210

9

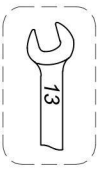

x2

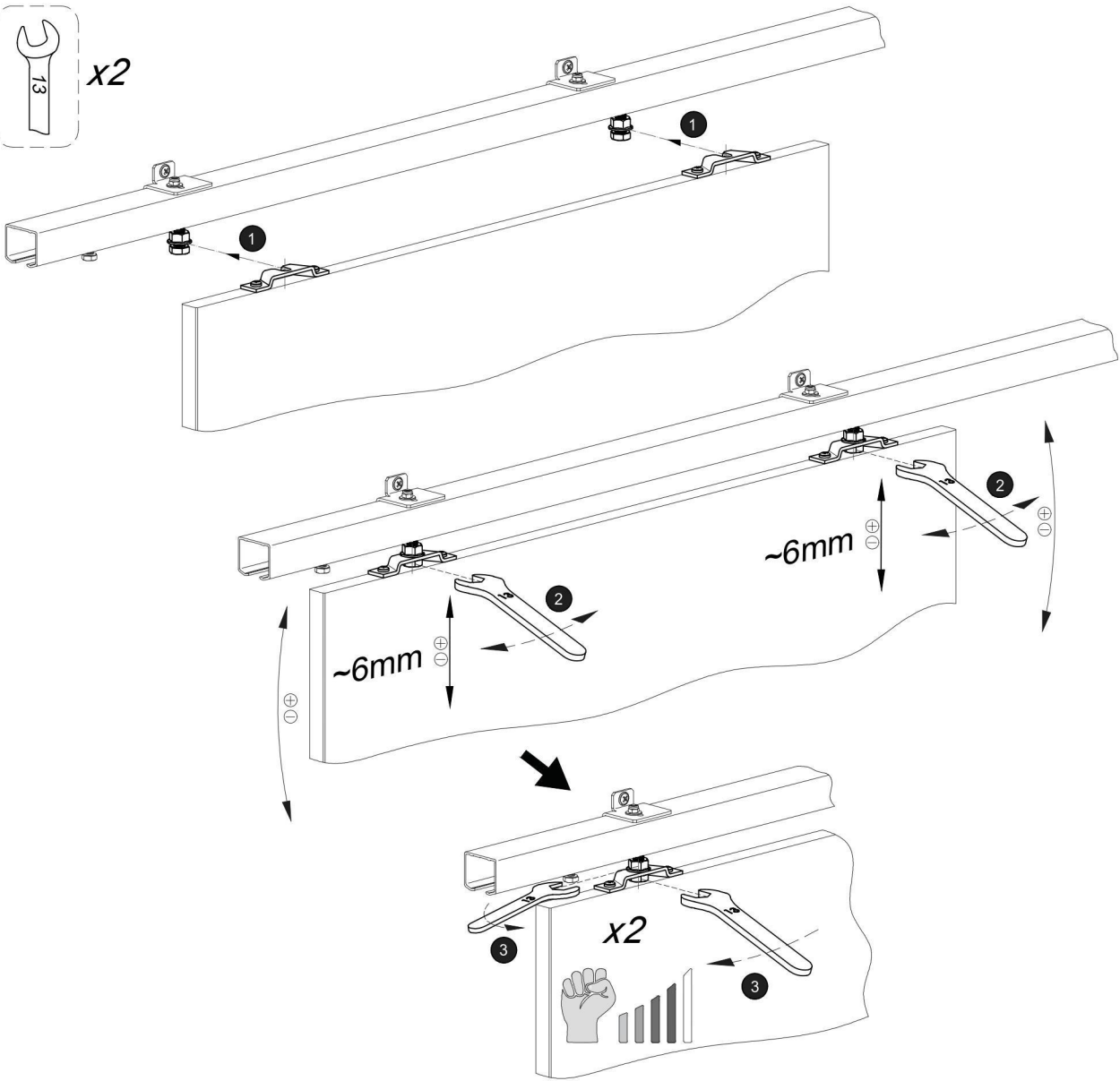

10

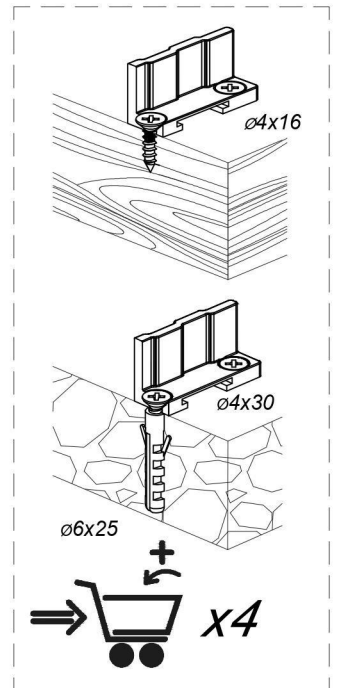
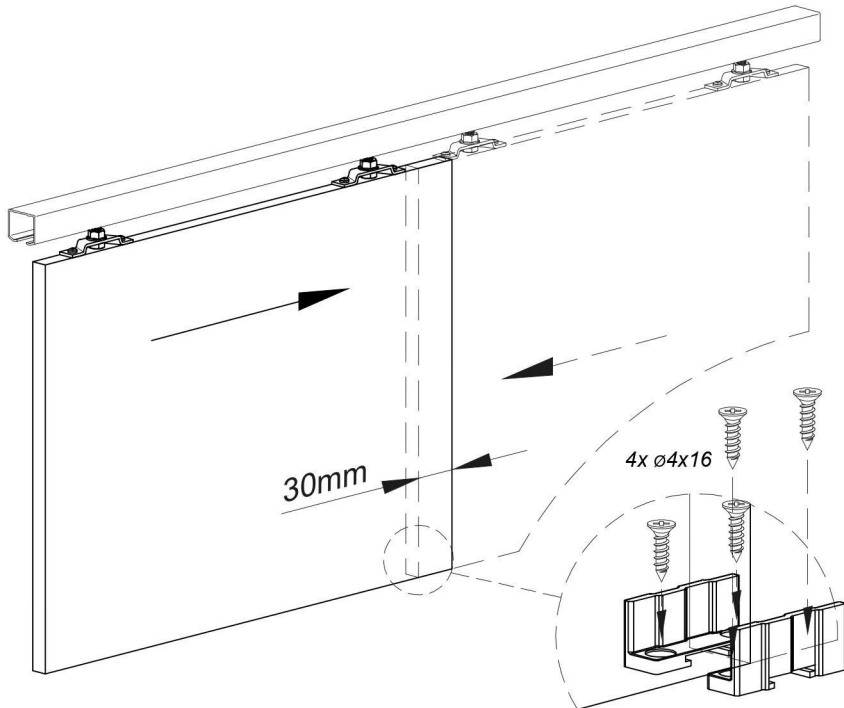

11

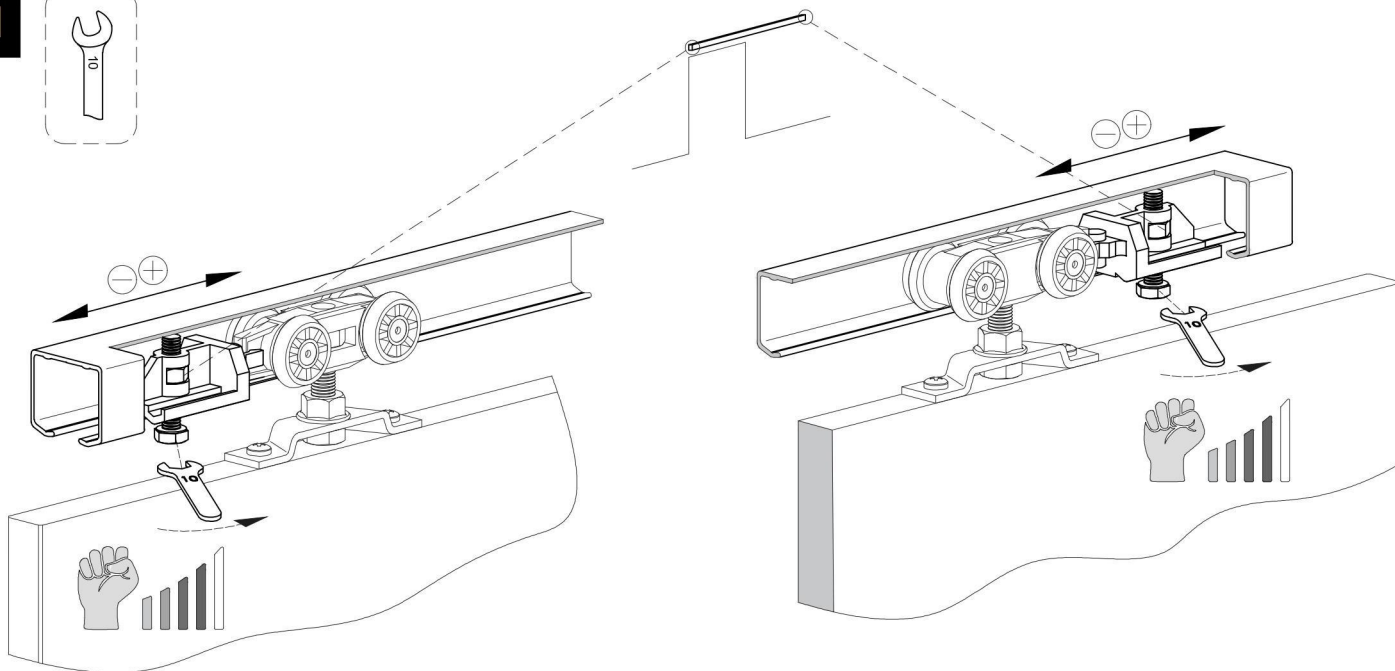

12

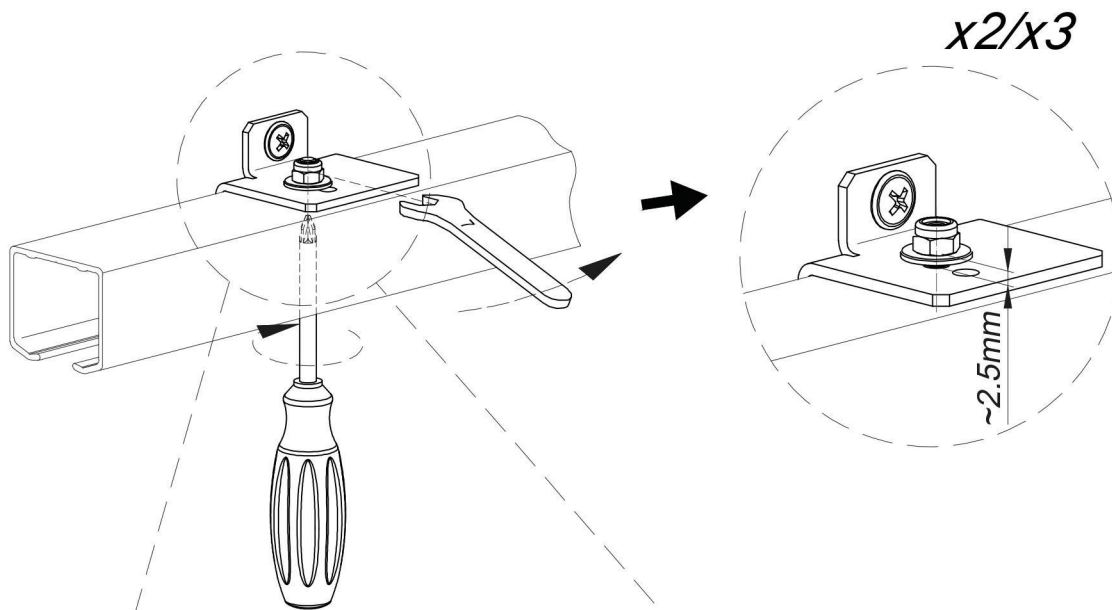
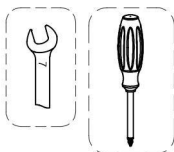

12a

"60"

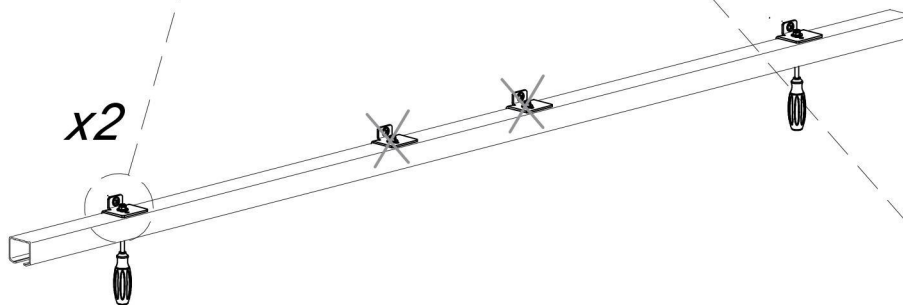

12b

"70" / "80" / "90"



12c

"100"

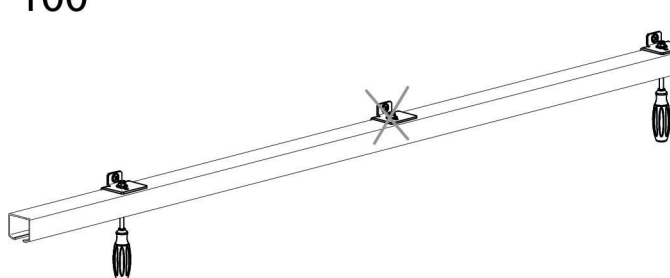

13a "60"

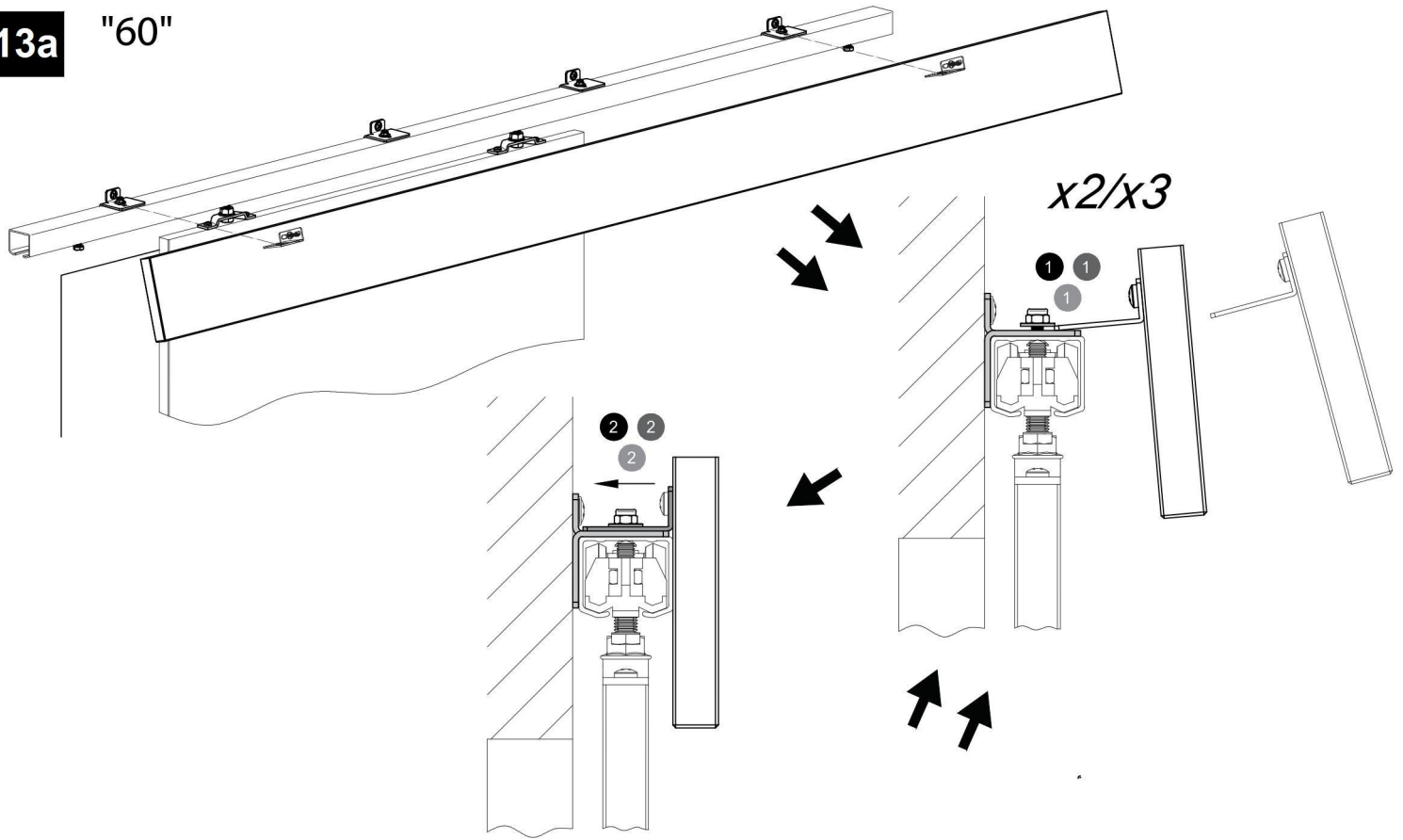

13b "70" / "80" / "90"

13c "100"

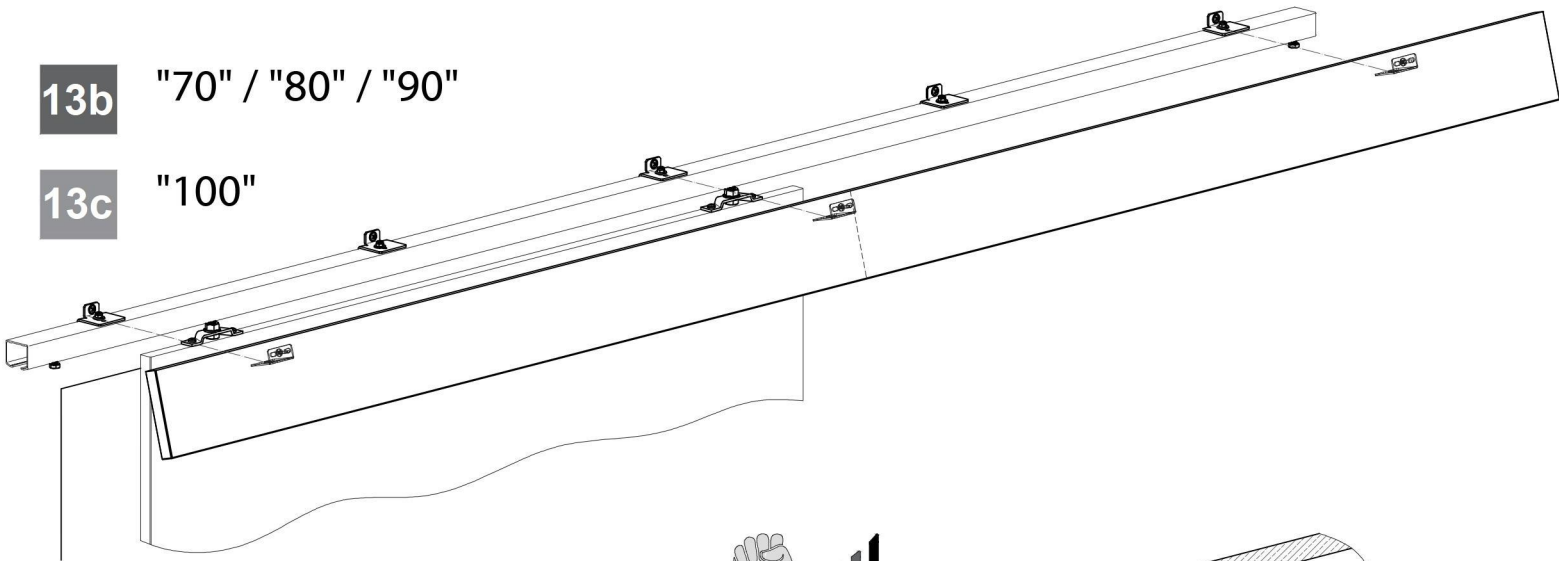

14

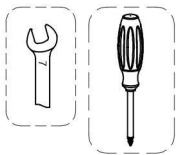

x4/x5

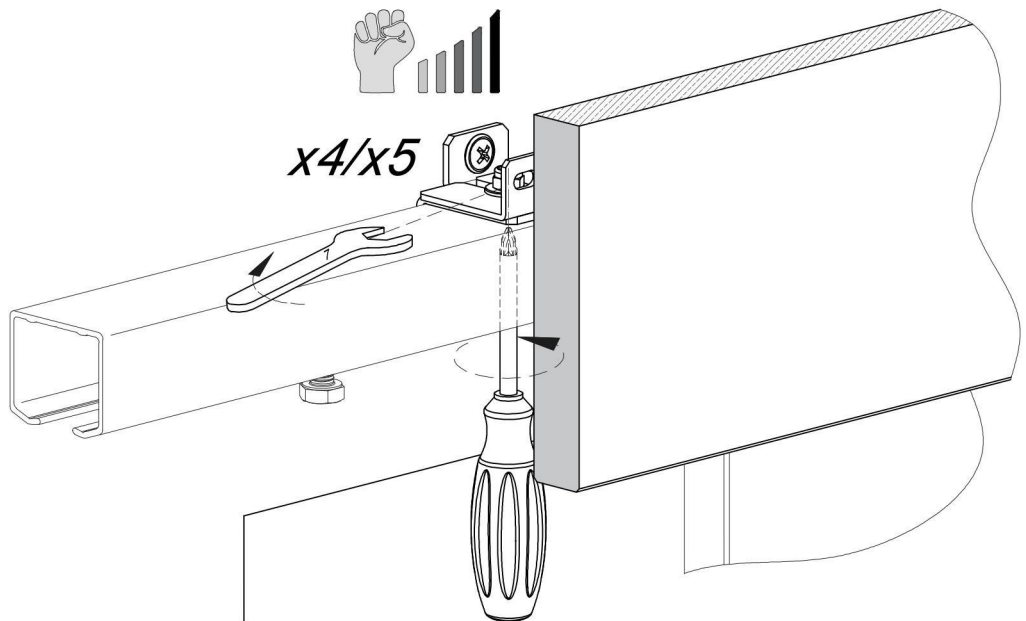

Additional Option

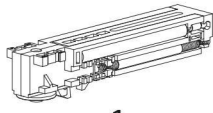

x1



x1



x2



x1



x1



x1

1

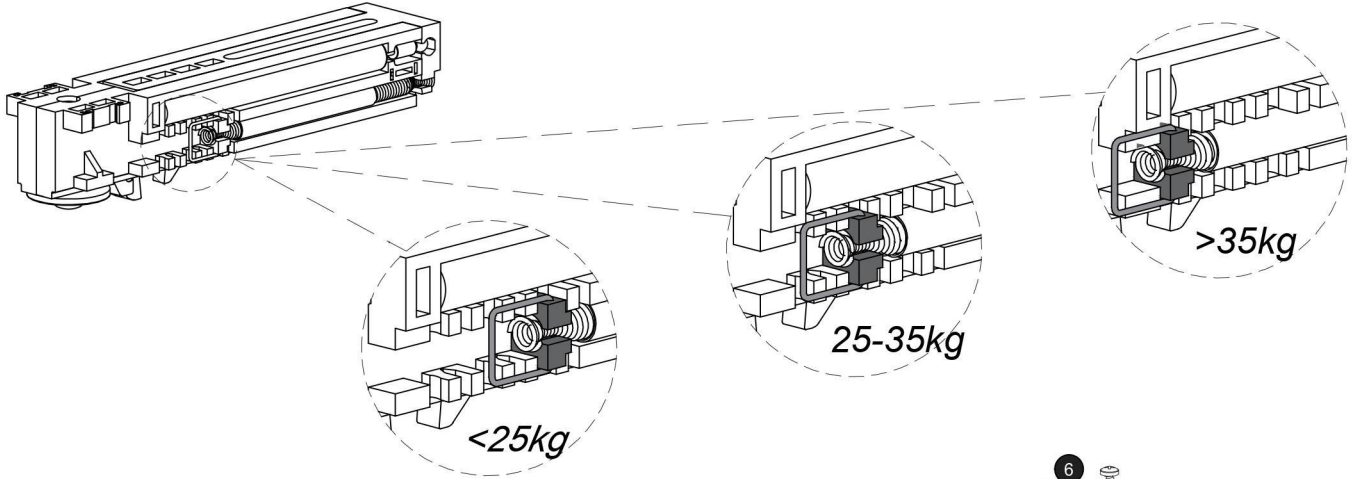

2

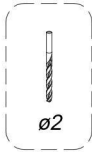

ø2

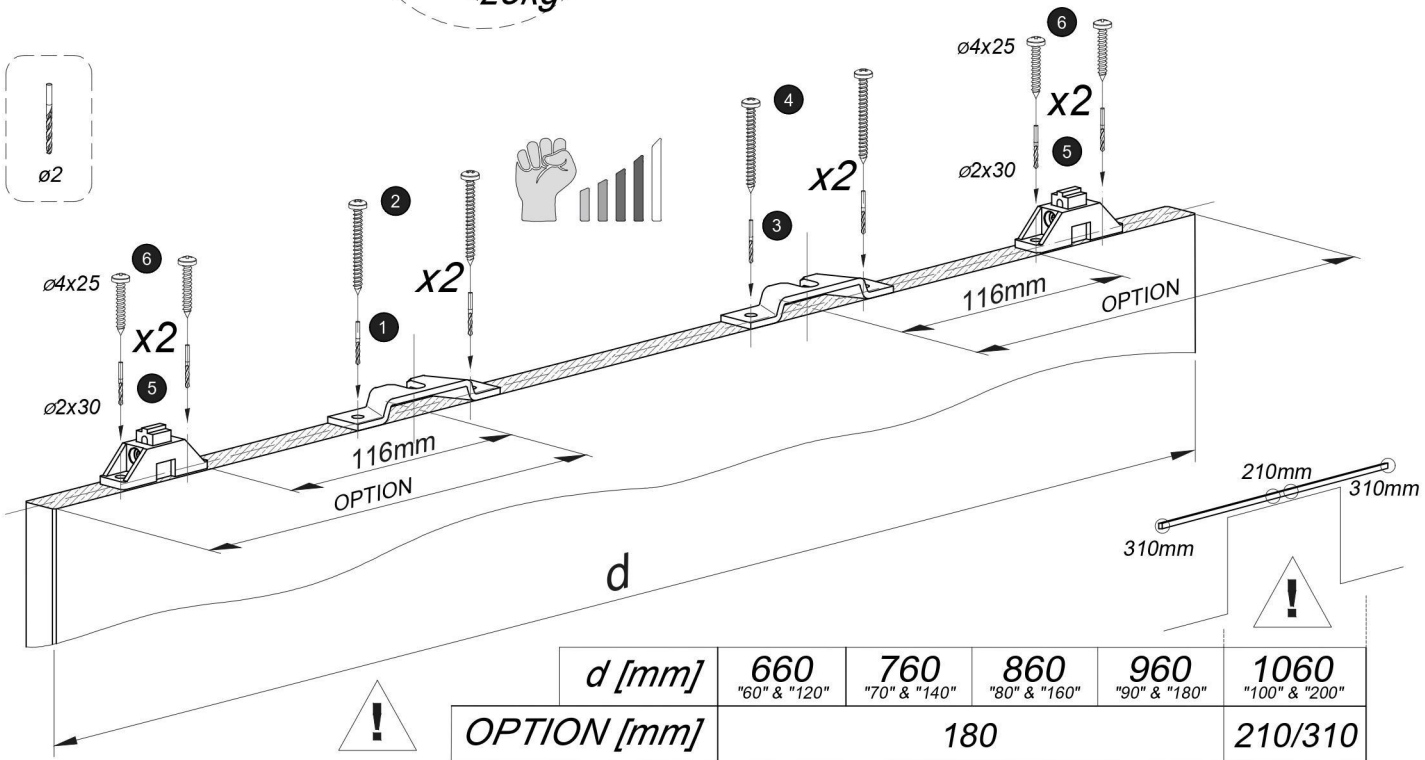

3



#2

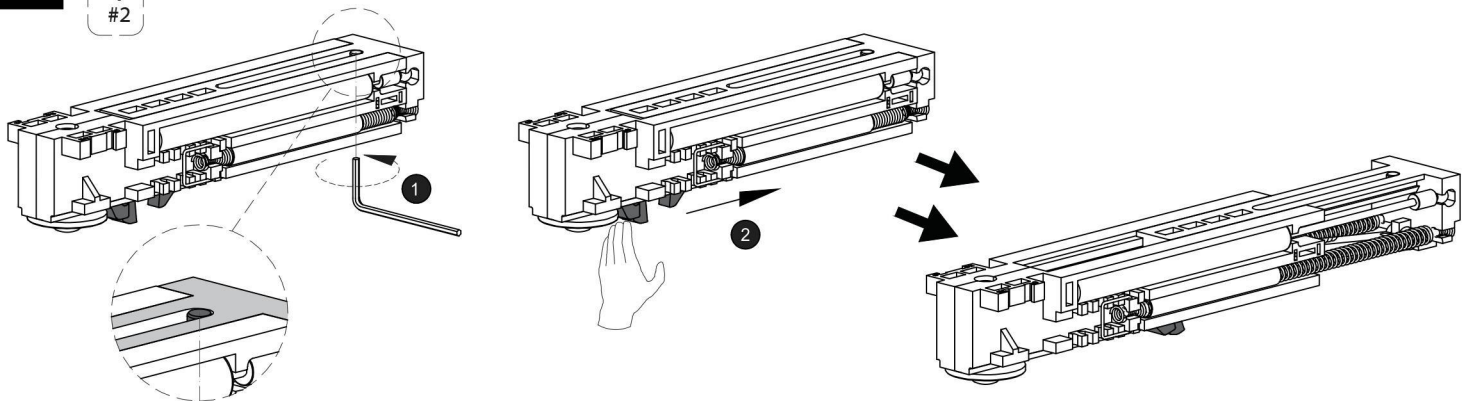

Additional Option

