

Round End Table

Instruction Manual

Mesita auxiliar redonda

Manual de instrucciones

Table d'Appoint Ronde

Manuel d'Instruction



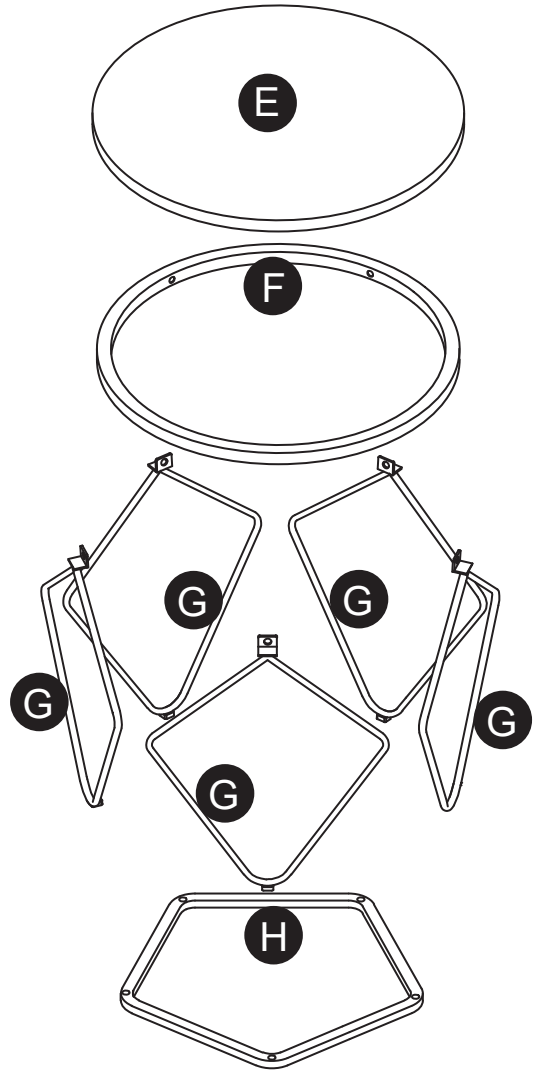
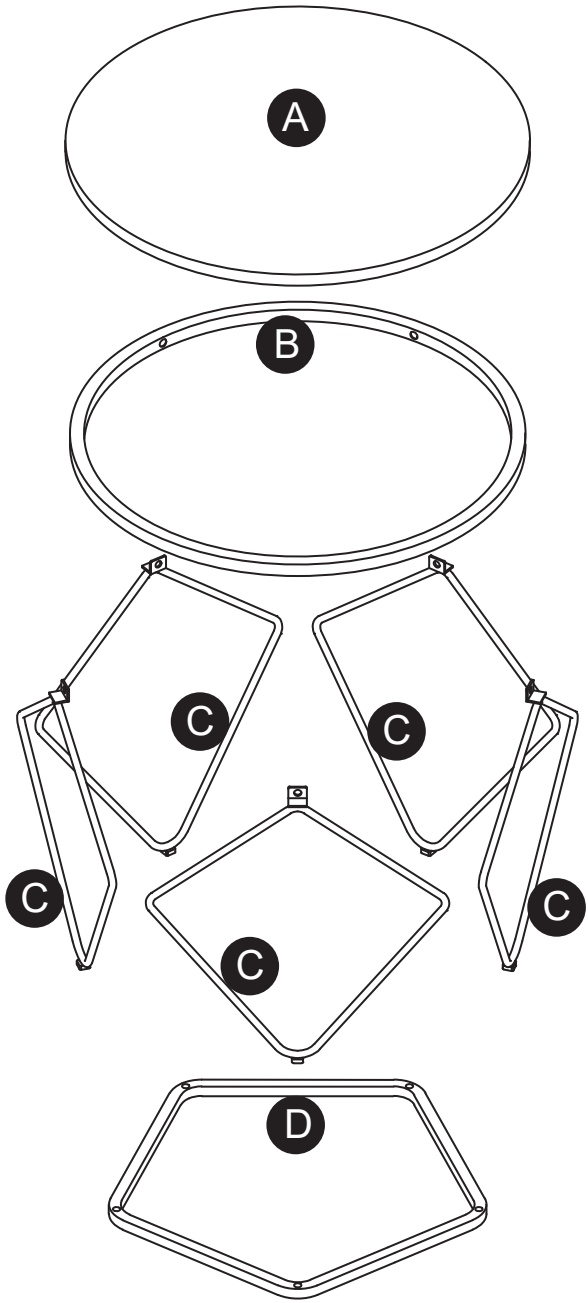

A X1

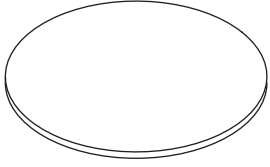

B X1

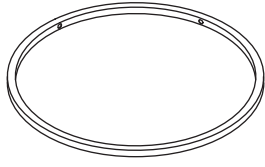

C X5

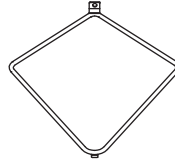

D X1

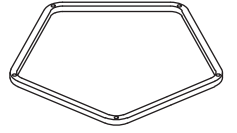

E X1

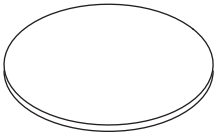

F X1

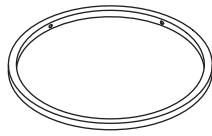

G X5

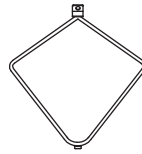

H X1

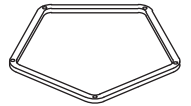

1 X1

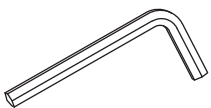

2 X10



M6*10mm

3 X10



M6*15mm

4 X8

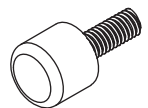

3

EN:  : Partially tighten the screws.

EN:  : Fully tighten the screws.

ES:  : Apriete parcialmente los tornillos.

ES:  : Apriete completamente los tornillos.

FR:  : Serrez d'abord les vis partiellement.

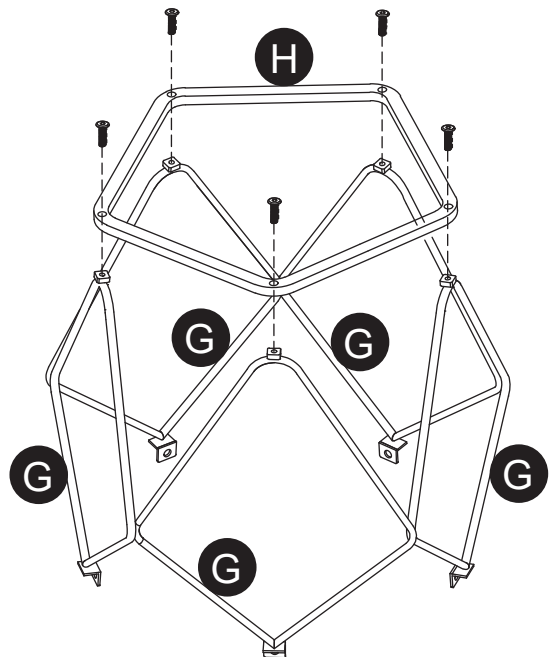
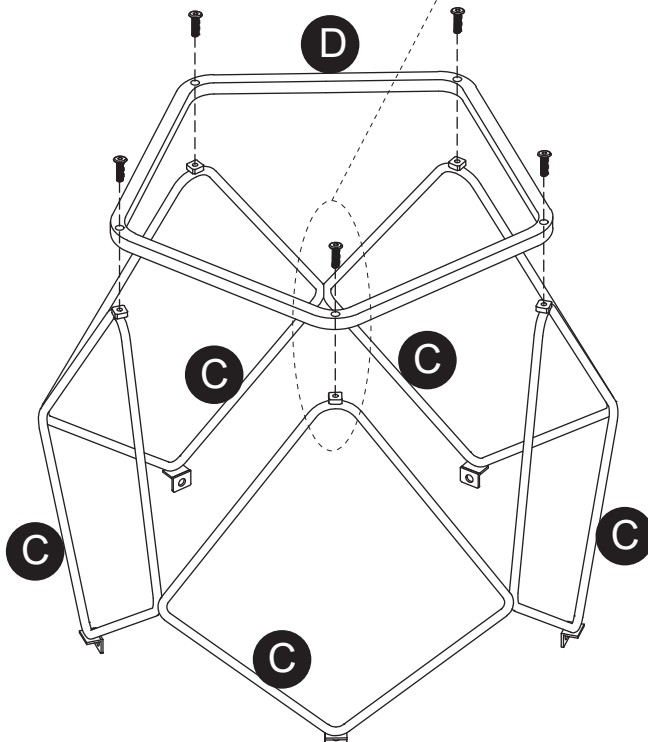
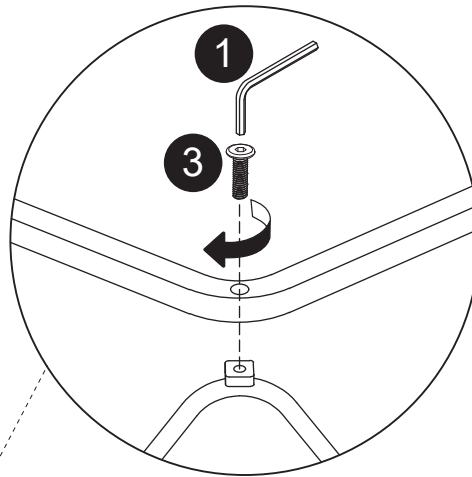
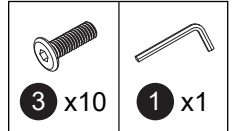
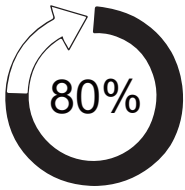

FR:  : Serrez les vis complètement.

Step 1

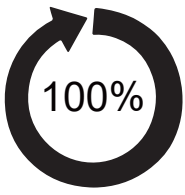

Step 2



 2 x10	 1 x1
--	---

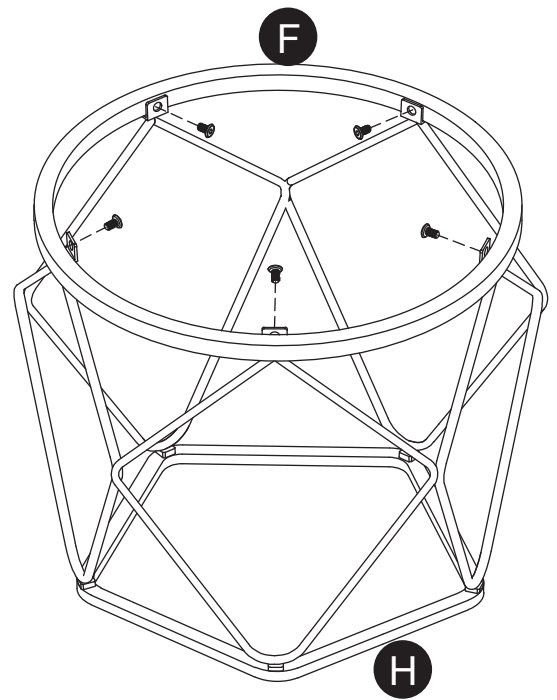
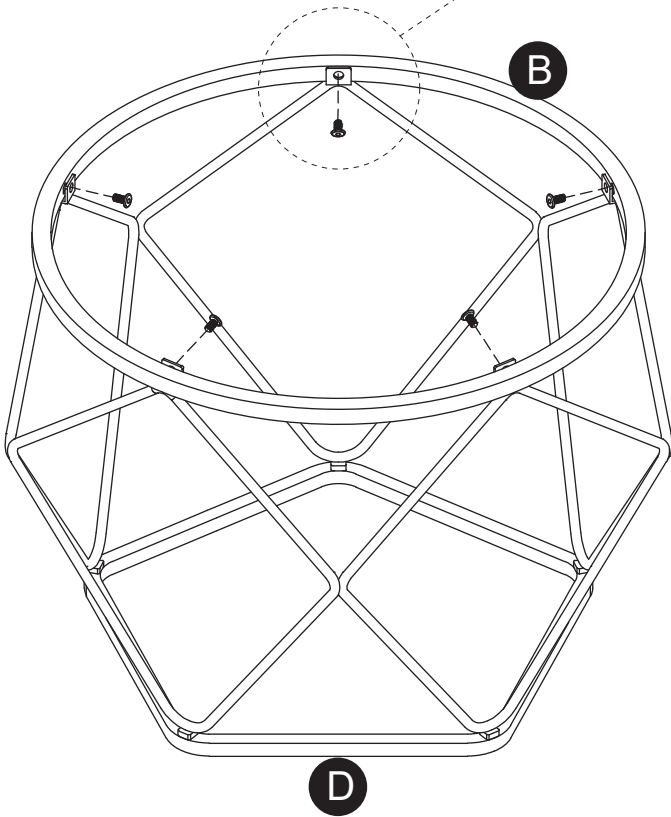
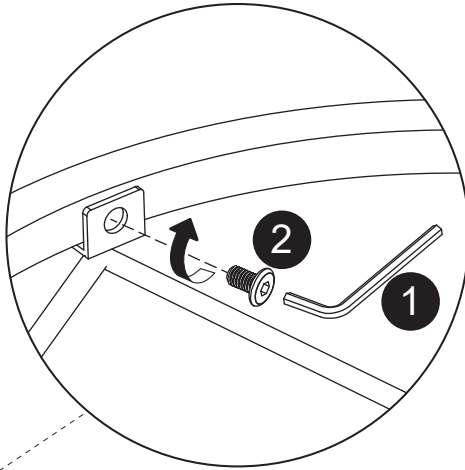

Step 3

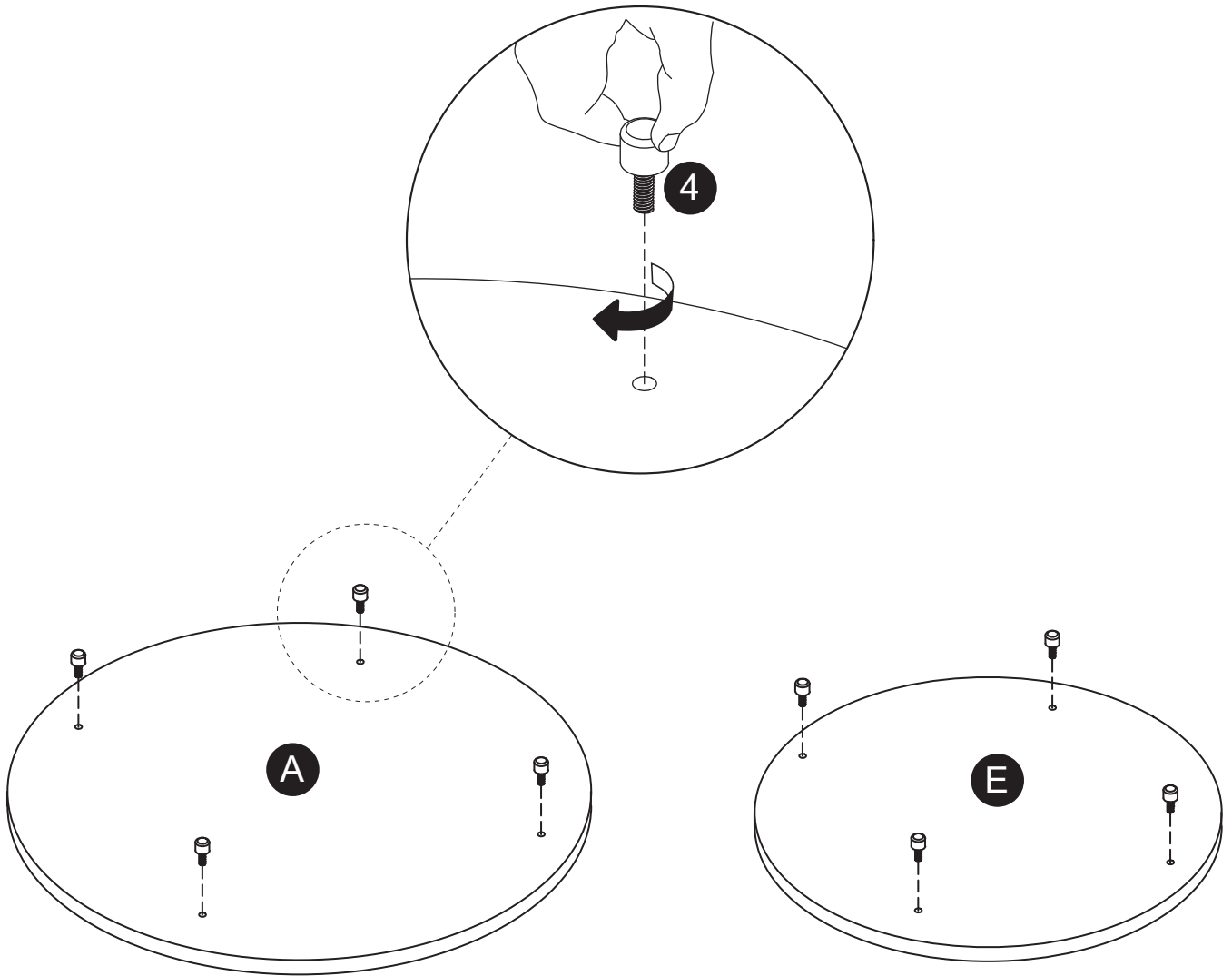

Step 4

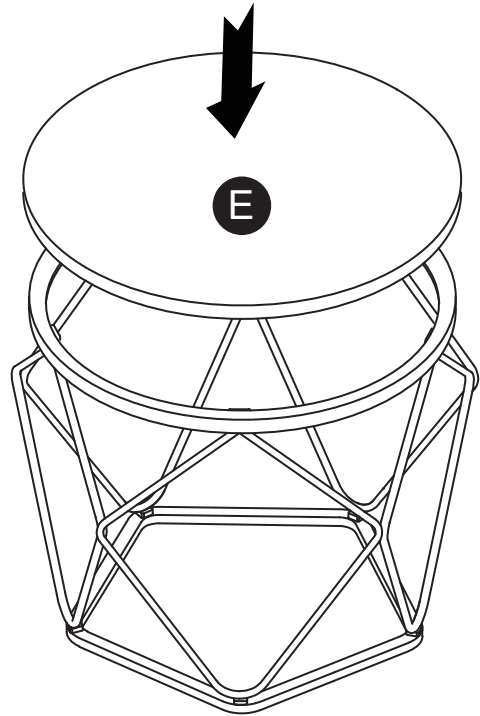
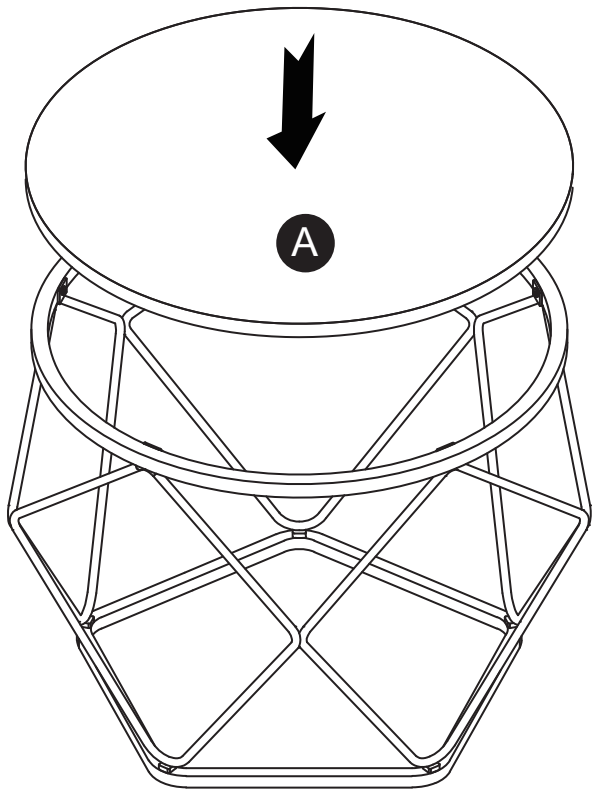

EN: **Note:** Fully tighten all screws.

ES: **Nota:** Apriete completamente todos los tornillos.

FR: **Remarque :** Serrez toutes les vis complètement.

