

ASSEMBLY INSTRUCTION

VENEER CHAIR

A Chair Back

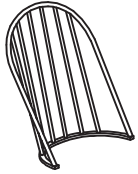

1 pc

B Left Leg



1 pc

C Right Leg



1 pc

D Seat



1 pc

E Center Cross Bar



1 pc

F Bolt with
Lock Washer
and Flat
Washer
1/4", 5/8"



10 pcs

G Pan Head Bolt
1/4", 1-3/4"



4 pcs

H Lock Washer



4 pcs

I Flat Washer



4 pcs

J Allen Wrench

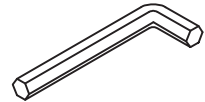

1 pc

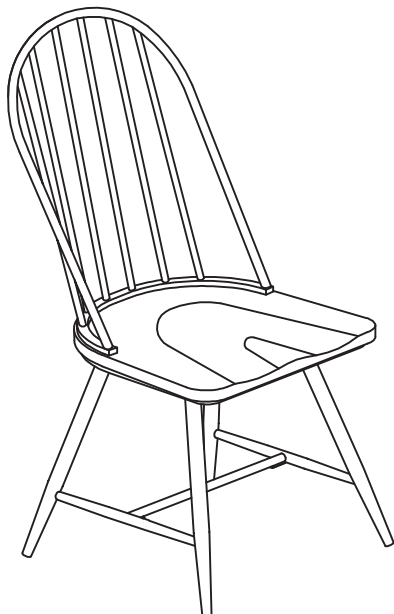

This page lists all the contents included in the box. Please take the time to identify the hardware as well as the individual components to this product. As you unpack and prepare for assembly, place the contents on a carpeted or padded area to protect them from damage.

1 Place and face down Seat (D) on a stable and smooth surface, attach Left Leg (B) and Right Leg (C) to the Seat (D) then tighten with Bolt with Lock Washer and Flat Washer (F) and Allen Wrench (J).

Take the allen wrench, and turn the bolts until the legs are secure.
DO NOT TIGHTEN COMPLETELY.
 Stop when you feel you are adding force to tighten the bolt.

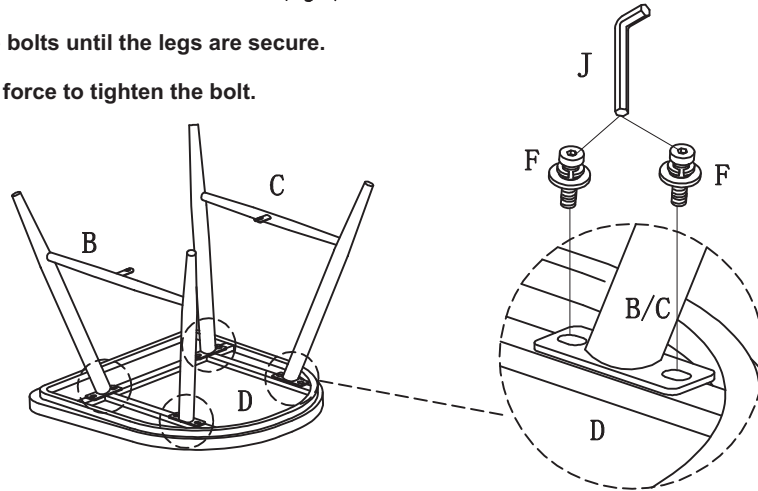

2 Align Center Cross Bar (E) to Left Leg (B) and Right Leg (C) then tighten with Bolt with Lock Washer and Flat Washer (F) and Allen Wrench (J).

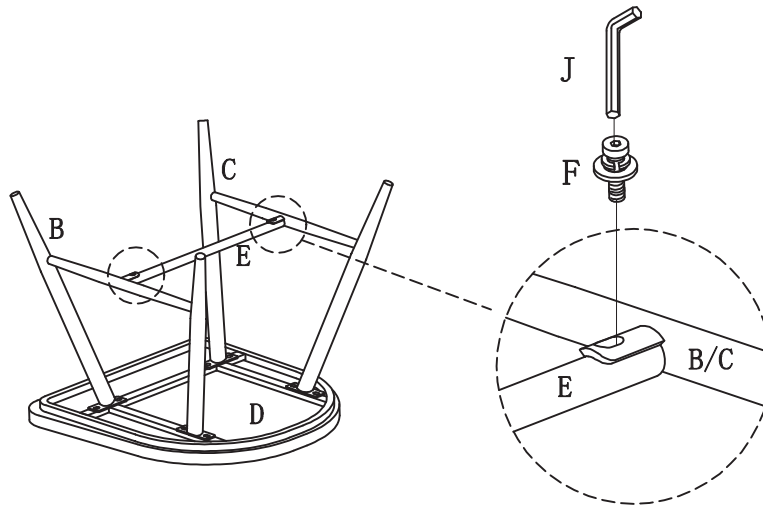

3 Place upright the assembled seat with legs, attach Chair Back (A) with Seat (D) then tighten with Pan Head Bolts (G), Lock Washer (H) and Flat Washer (I), using Allen Wrench (J).

Stand chair up on an even surface and check that it is balanced.
 If there is a slight wobble, apply downward pressure in the corner where a leg is uneven. Keeping pressure in that corner, tighten all bolts.
 If balanced, apply downward pressure evenly in the center and tighten all bolt.
 Do not over-tighten beyond hole depth.

Helpful tip:
 -Instead of applying downward pressure while reaching under to tighten bolts, have someone sit in the chair while you tighten the bolts.

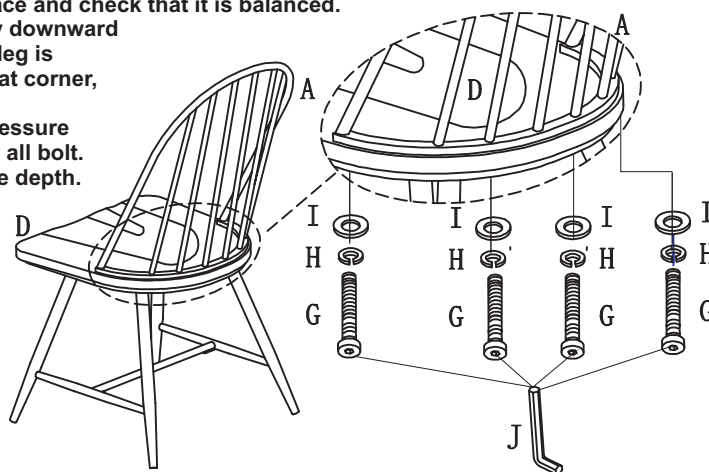

Cleaning & Care

Treat surface with care. Surface is resistant to scratches but is not scratch resistant. Clean surfaces with a dry or damp soft cloth. Do not use abrasive cleaners. Hardware may loosen over time. Periodically check that all connections are tight.