

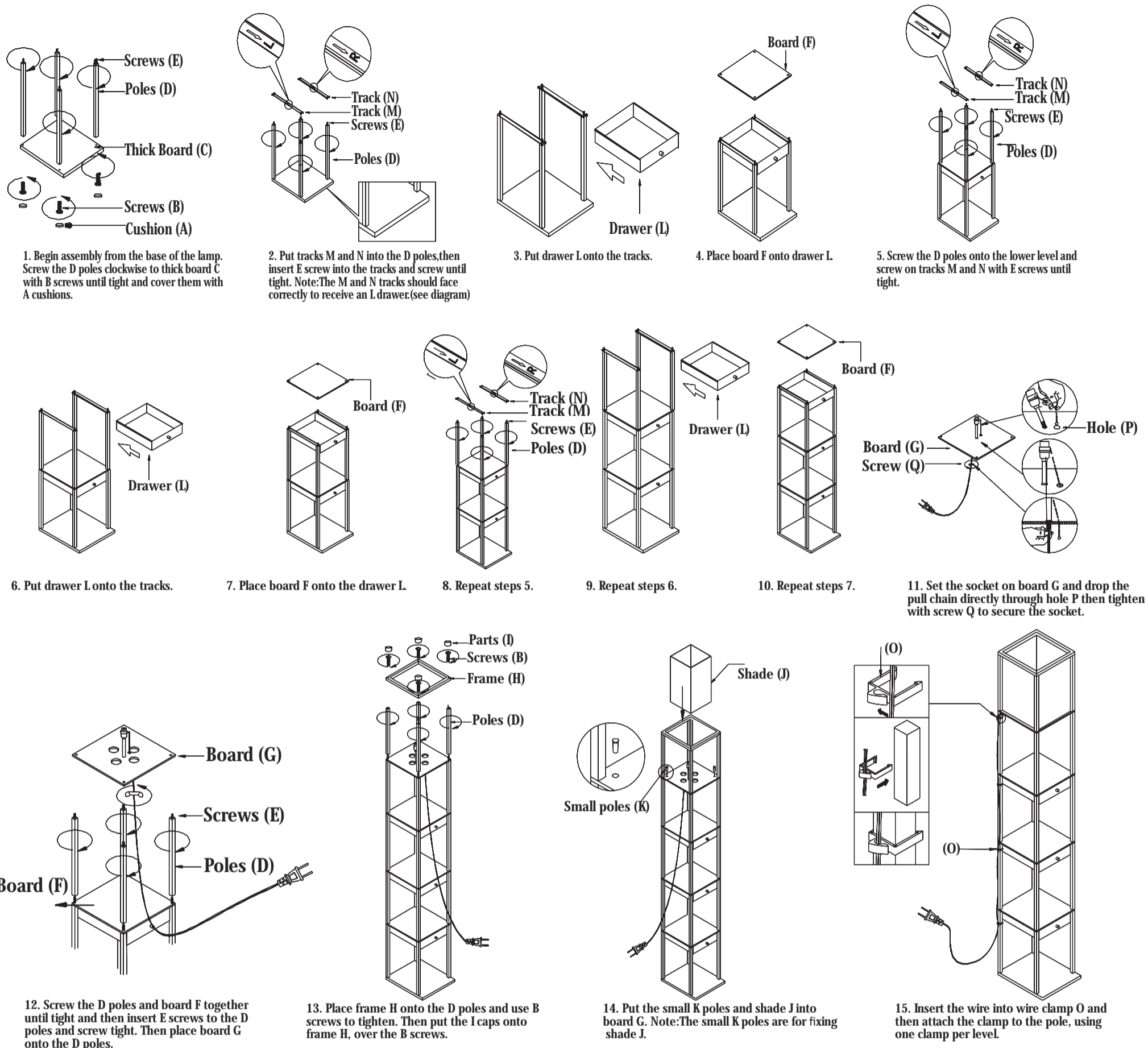







Brightech® MAXWELL FLOOR LAMP-DRAWER EDITION

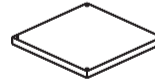

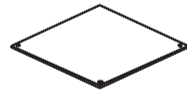
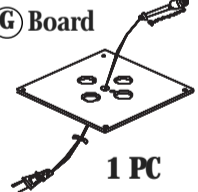
(A) Stick Cushion  4 PCS	(B) Screw  8 PCS	(C) Thick Board  1 PC	(D) Long Pole  20 PCS	(E) Screw  16 PCS	(F) Board  3 PCS	(G) Board  1 PC	(H) Frame  1 PC
(I) Cap  4 PCS	(J) Shade  1 PC	(K) Small Pole  4 PCS	(L) Drawer  3 PCS	(M) Track  3 PCS	(N) Track  3 PCS	(O) Wire Clamps  4 PCS	

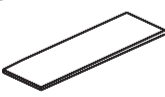
Extend Your Warranty From 3 Years To 5 Years

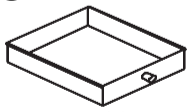
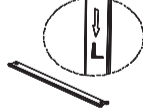
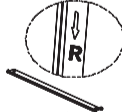
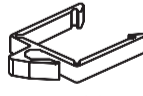
To extend your warranty by 2 extra years for a total of 5 years' warranty, register your purchase by filling in the brief form at brighttechshop.com/pages/extended-warranty/.

Thank you for your purchase of your Brightech lamp. Please contact us via our website or email if you have any issues or concerns.

www.brighttechshop.com

wecare@brighttechshop.com