

DAYBED

WARNING!

- Due to the size of this bed we recommend assembling it in the room intended for use.
- Check the packaging to make sure you have all the parts listed on this instruction.
- Before use, make sure this bed is fully assembled. Do not over-tighten screws.
- Do not use power tools to assemble this bed. Tools are not needed.
- This product should be used only on firm, level ground.
- Do not destroy the packaging until after the product is fully assembled.
- To move this bed, please disassemble firstly.
- Keep all packaging box, bags and small parts out of the reach of children.
- Make sure bed frame's legs are in contact with the ground all the time.
- Do not jump, stand on this bed.
- Two people needed to assemble bed. Do not assemble without additional help.
- Make sure the entrapment distance; distance between the edge of the mattress and any of the support rails on the headboard or footboard is either greater than 9" or less than 3".
Size mattress accordingly.

!!!ADVERTENCIAS!!!

- Debido al tamaño de esta cama, le recomendamos que la instale en la habitación diseñada para su uso.
- Verifique el empaque para asegurarse de que tenga todas las piezas descritas en estas instrucciones.
- Antes de usarse, asegúrese de que esta cama esté completamente ensamblada. No apriete demasiado los tornillos.
- No utilice herramientas eléctricas para montar esta cama. Las herramientas no son necesarias.
- Este producto se debe utilizar solo en superficies firmes y niveladas.
- No destruya el empaque hasta que el producto esté completamente ensamblado.
- Para trasladar esta cama, por favor desmóntela primero.
- Mantenga todos el empaque, bolsas y partes pequeñas fuera del alcance de los niños.
- Asegúrese de que las patas del marco de la cama estén en contacto con el suelo todo el tiempo.
- No salte y no se pare en esta cama.
- Dos personas necesitaban armar la cama. No ensamble sin ayuda adicional.
- Asegúrese de que la distancia de atrapamiento, la distancia entre el borde del colchón y cualquiera de los rieles de soporte en la cabecera o el reposapiés sean superiores a 9 pulgadas o inferiores a 3 pulgadas.
Dimensione el colchón en consecuencia.
- Limpie este producto solamente con un paño húmedo. No use cloro ni limpiadores abrasivos.

AVERTISSEMENTS!

- A cause de la taille de ce lit, nous préconisons de le monter dans la pièce où il sera utilisé.
- Vérifier les cartons pour vous assurer que vous avez toutes les pièces dans la liste.
- Avant de vous en servir, il faut que ce lit soit complètement assemblé. Ne pas trop serrer les vis.
- Ne pas utiliser les outils électriques pour monter ce lit. Il n'y a pas besoin d'outils.
- Ce produit est sensé être utilisé que sur un plancher ferme et plat.
- Ne pas détruire les cartons avant d'avoir complètement monté le produit.
- Pour changer ce lit de place, veuillez le démonter d'abord.
- Garder la boîte, les sacs et les petites pièces hors de la portée des enfants.
- Vous assurer que les pieds du cadre du lit sont toujours en contact avec le sol.
- Ne pas sauter ni vous mettre debout sur ce lit.
- Dos personas necesitaban armar la cama. No ensamble sin ayuda adicional.
- Vous assurer de la distance d'happement: distance entre le bout du matelas et n'importe lequel des rails de support sur la tête du lit ou le pied du lit est plus de 9" ou moins de 3".
Prenez un matelas de la taille du lit.
- Nettoyez cet article avec un chiffon humide uniquement. N'utilisez pas d'eau de javel ni des nettoyeurs abrasifs.

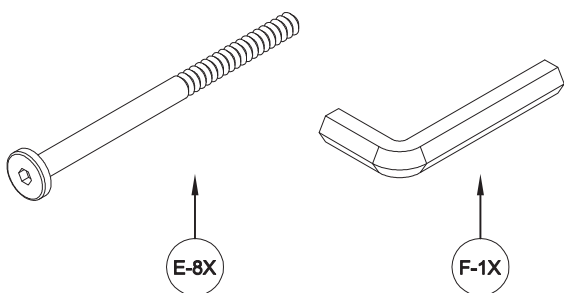
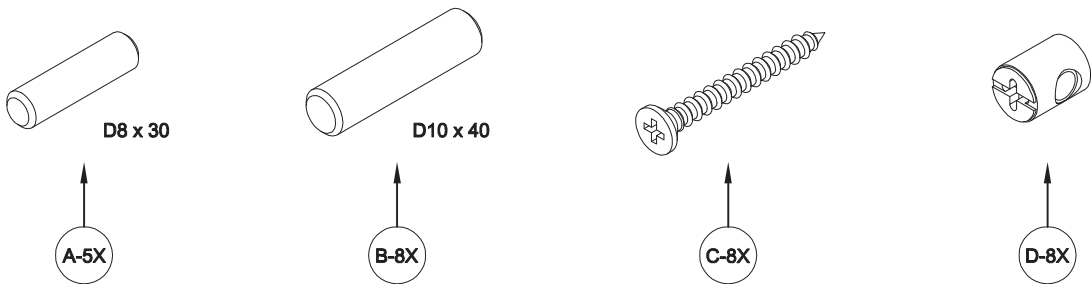
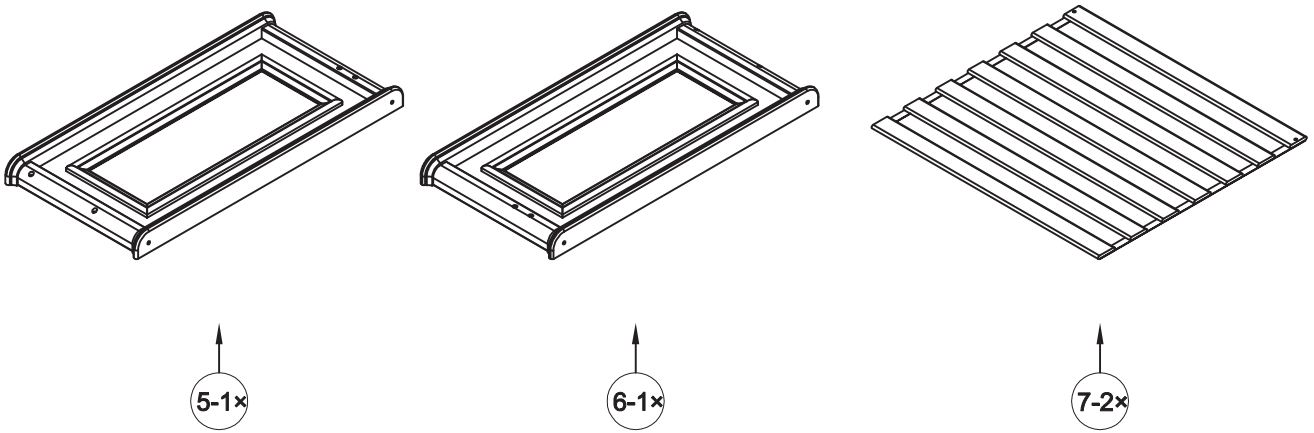
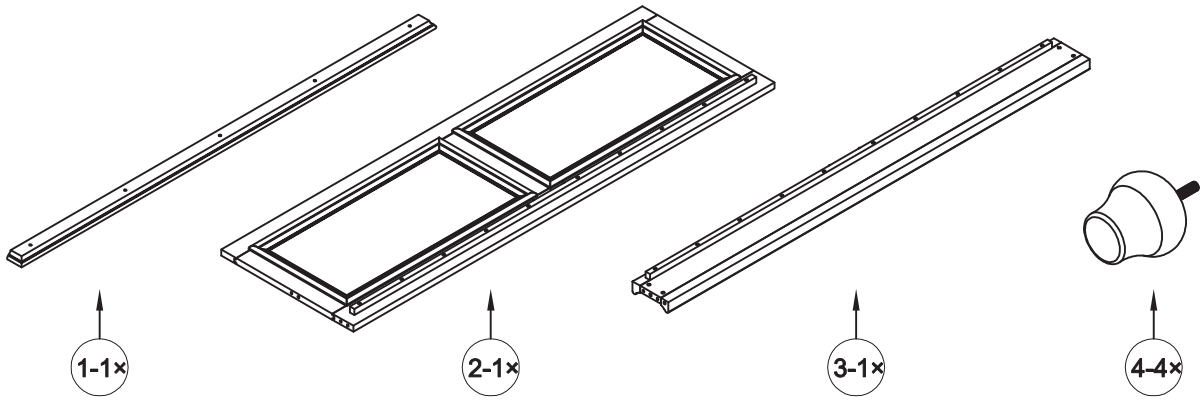

Phillips Screwdriver Needed
**Not Included

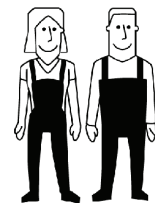

2

STEP 1

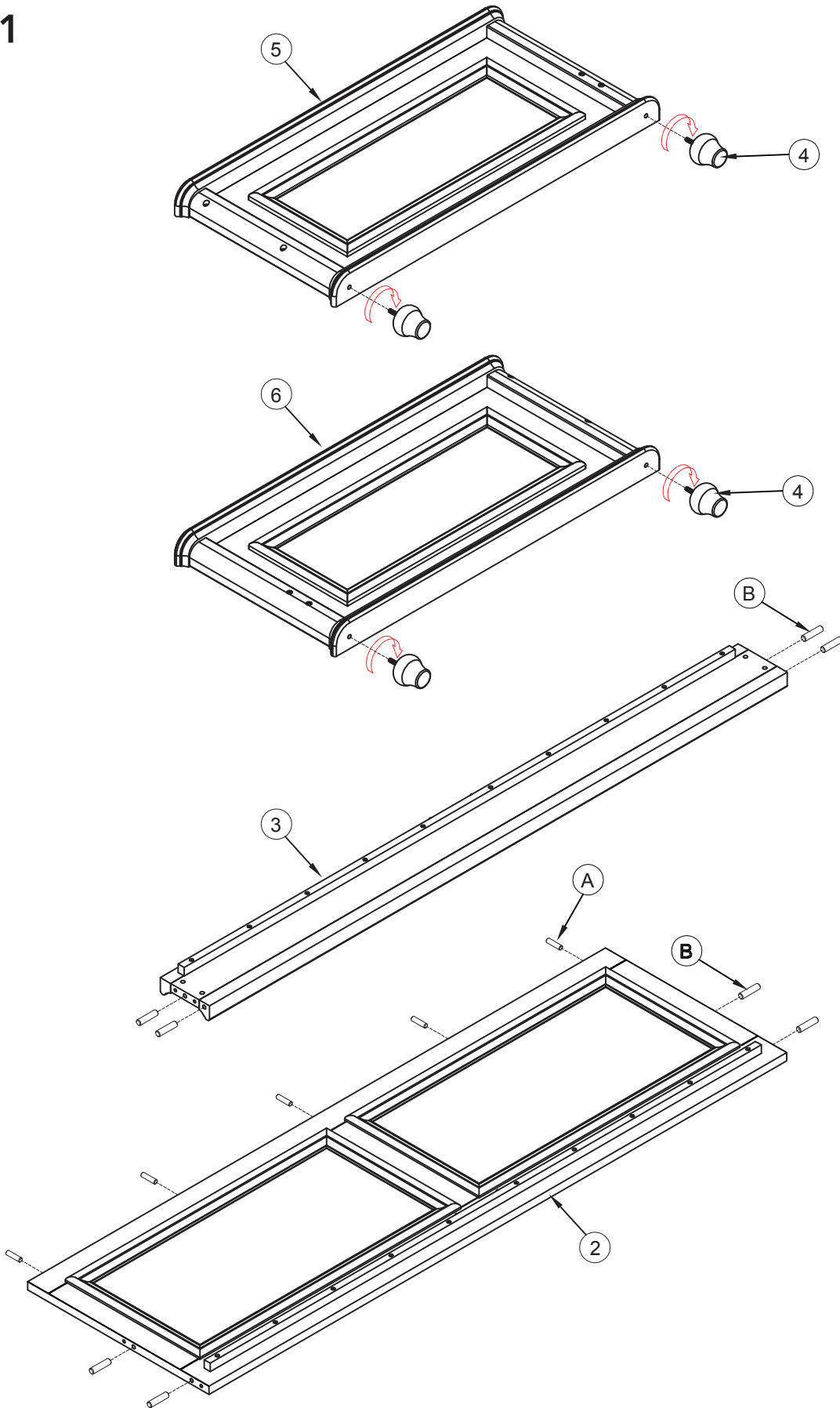

STEP 2

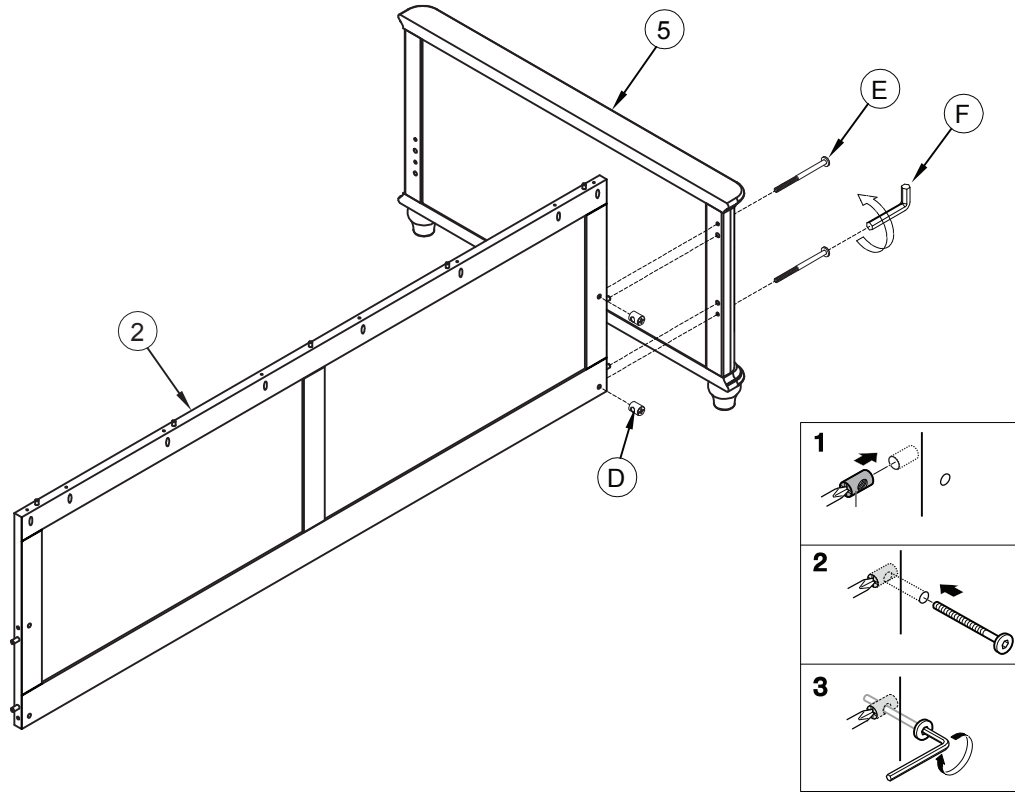

STEP 3

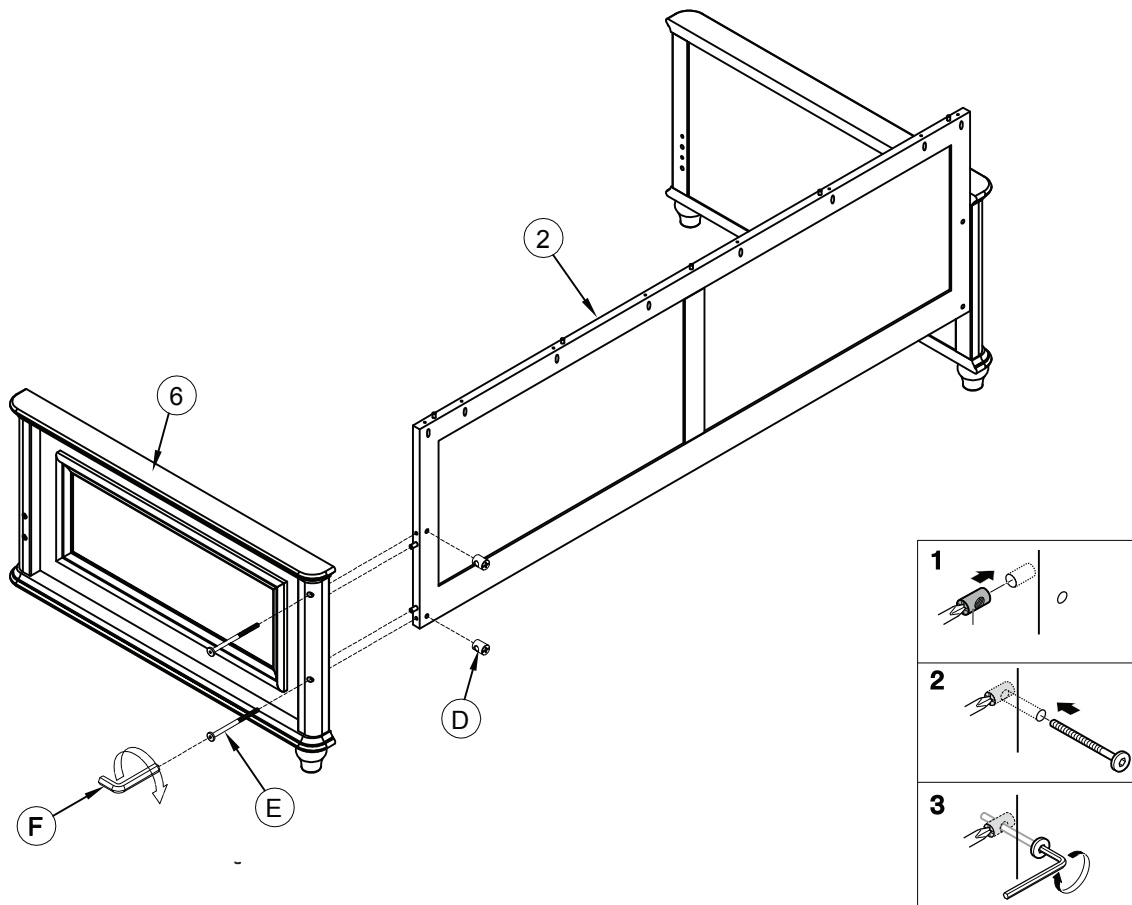

STEP 4

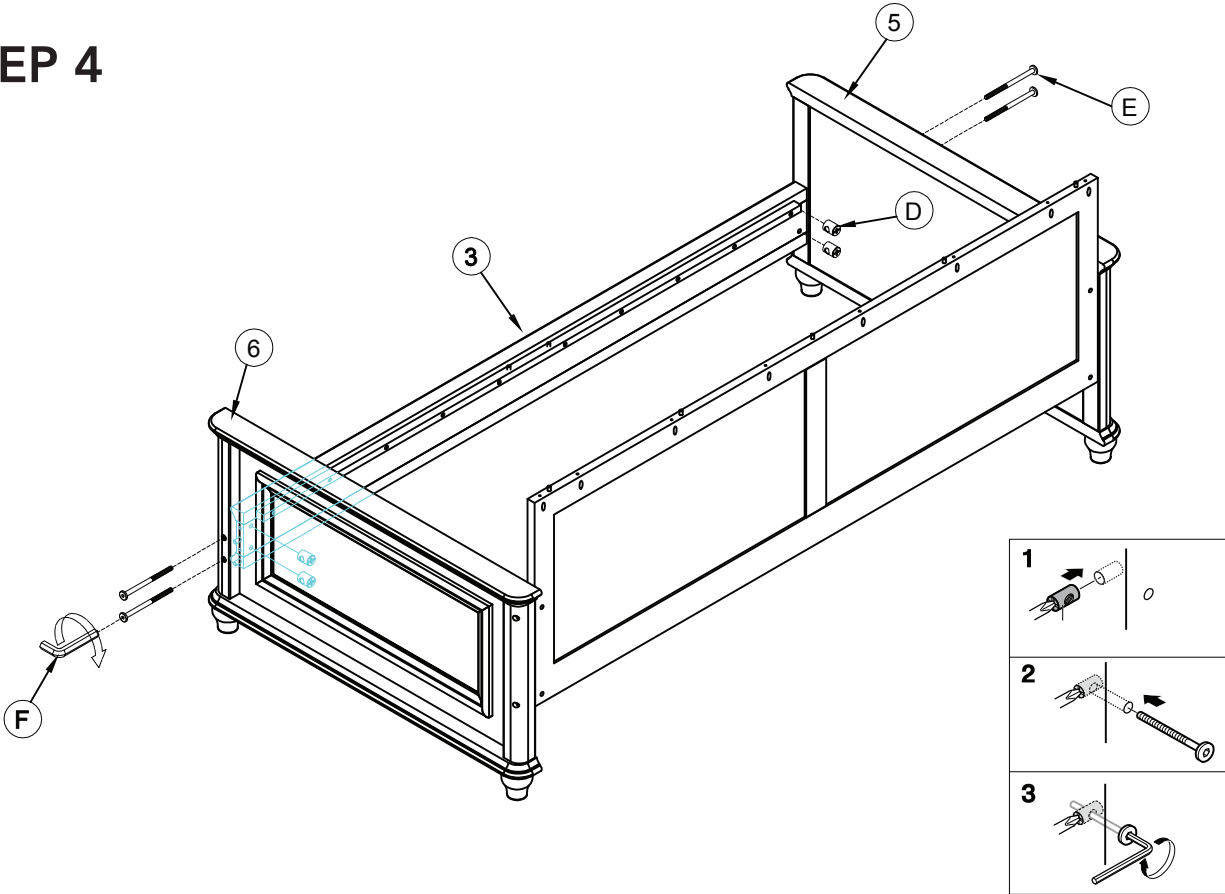

STEP 5

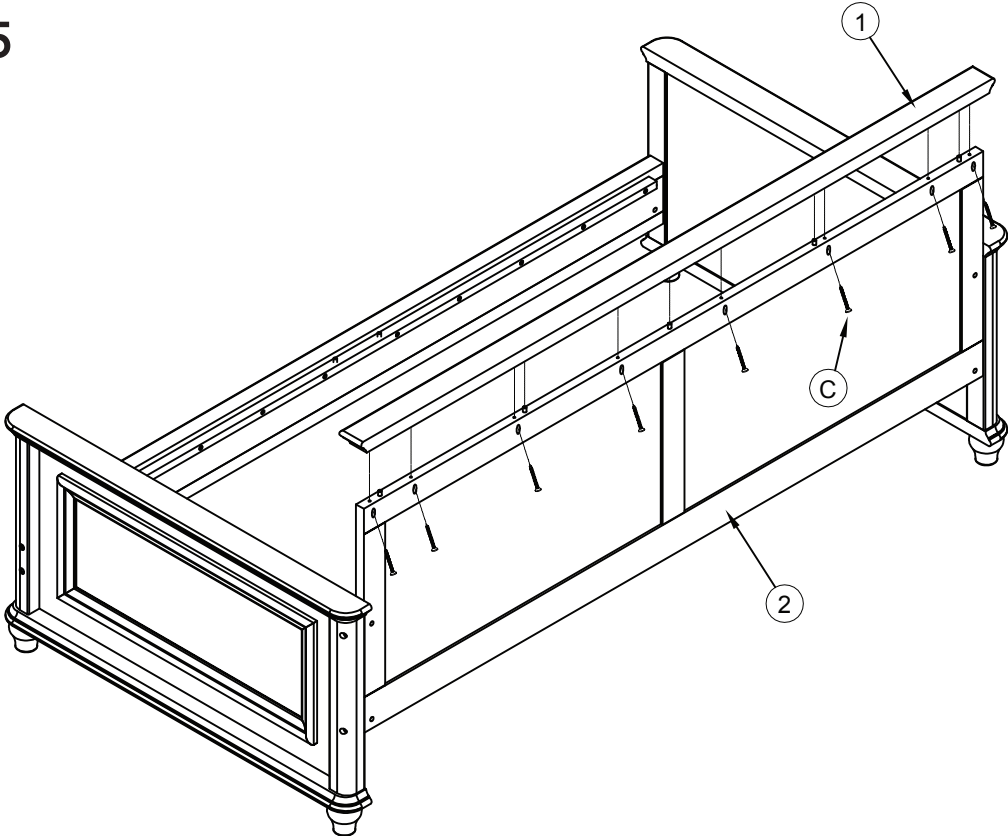

STEP 6

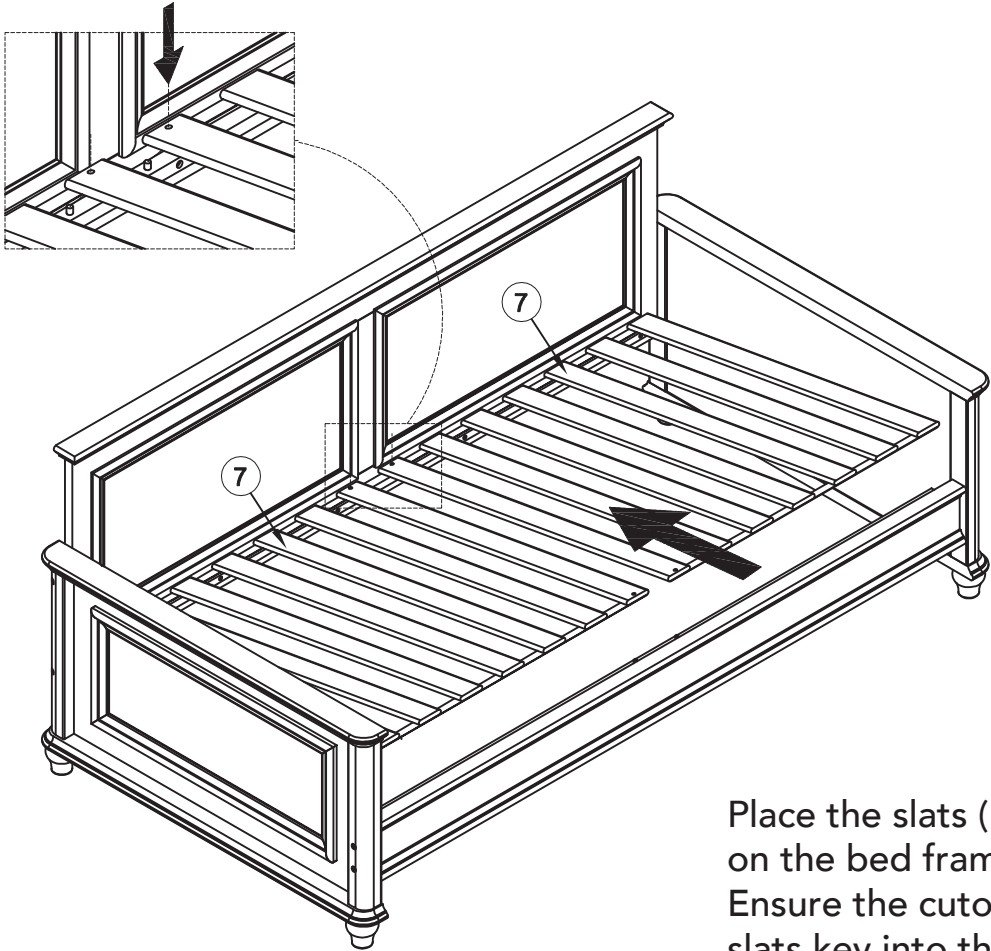

Place the slats (Part 7) on the bed frame. Ensure the cutout on the slats key into the studs on the frame as shown.

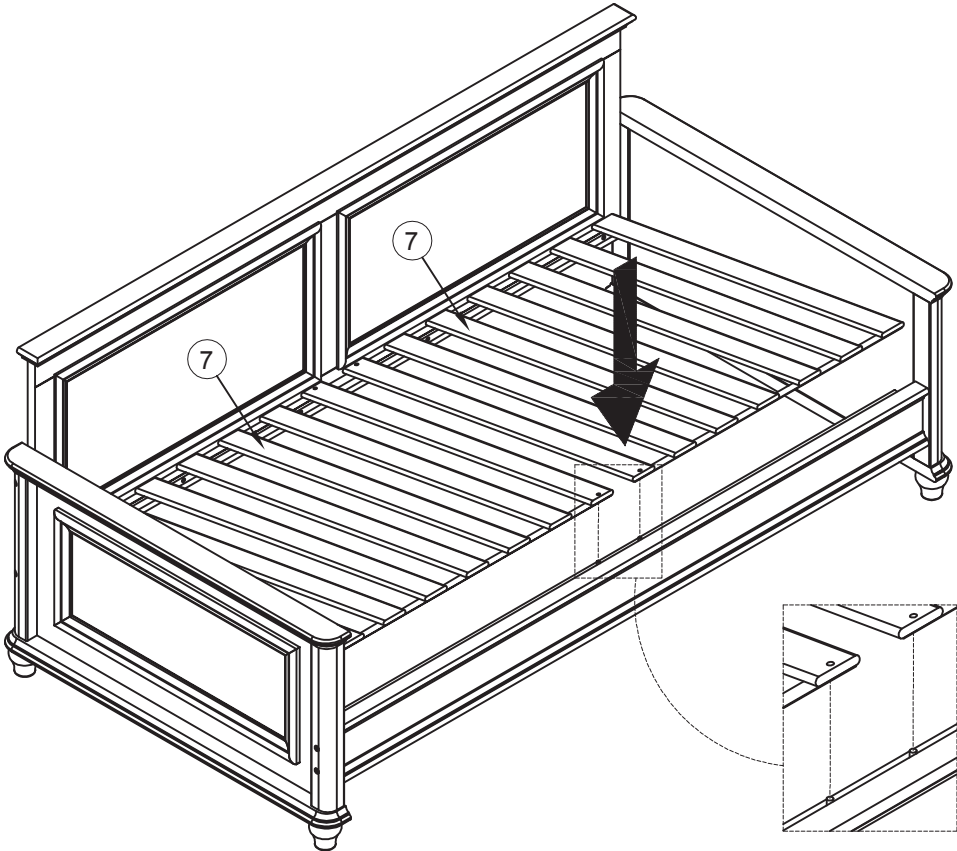

1 YEAR LIMITED WARRANTY

We are warranted for a one (1) year period from the date of purchase against defects in materials and/or workmanship. Unless there is a clear warranty issue, the furniture are not returnable to us. During this warranty period, if the product is deemed to be defective, our responsibility for the defective product is limited to replacement as stated below. All transportation costs are the responsibility of the purchaser during the entire warranty period. This Limited Warranty does not apply to and is otherwise invalid as to the following, without limitation: (1) Normal wear and tear; (2) Normal soiling from everyday use; (3) Product used for commercial, institutional, or rental purposes; (4) Damage caused by structural problems or appliance malfunctions; (5) Damage caused by or related to fire, natural disaster, flood, theft, vandalism or other crimes, or any other loss that is covered under an insurance policy; (6) Damage caused by extraordinary use; (7) Damage occurred during moves between residences or while in storage; or (8) smoke, fire, floods, or other acts of God.

WE SHALL NOT BE LIABLE FOR INCIDENTAL OR CONSEQUENTIAL DAMAGES RESULTING FROM THE USE OF THIS PRODUCT OR ARISING OUT OF ANY BREACH OF THIS WARRANTY AND THE EXCLUSIVE REMEDY FOR BREACH OF THIS WARRANTY SHALL BE REPLACEMENT OF THE PRODUCT. THE EXPRESS LIMITED WARRANTY SET FORTH HEREIN IS THE SOLE WARRANTY GIVEN BY US, SHALL ONLY EXTEND TO THE ORIGINAL PURCHASER AND SHALL NOT EXTEND TO ANY SUBSEQUENT OWNER OR OTHER TRANSFEREE OF THE PRODUCT. THE REMEDIES DESCRIBED ABOVE ARE YOUR SOLE AND EXCLUSIVE REMEDIES AND OUR ENTIRE LIABILITY FOR ANY BREACH OF THIS LIMITED WARRANTY. OUR LIABILITY SHALL UNDER NO CIRCUMSTANCES EXCEED THE ACTUAL AMOUNT PAID BY YOU FOR THE DEFECTIVE PRODUCT. FOR SALES TO ANY PURCHASER, OTHER THAN THE ORIGINAL PURCHASER (AS DEFINED HEREIN), ALL IMPLIED WARRANTIES INCLUDING, BUT NOT LIMITED TO, ANY IMPLIED WARRANTY OF MERCHANTABILITY OR FITNESS FOR A PARTICULAR PURPOSE OR USE, ARE EXCLUDED AND DISCLAIMED. This Limited Warranty is made exclusively by us and is not made on behalf of its distributors or any other party and no one is authorized to assume or undertake for us any other liability in connection with the sale of the product. Some jurisdictions do not allow for the disclaimers of implied warranties or the exclusion of limitation of incidental or consequential damages, so the above limitations may not apply to you. In the event that the disclaimer of implied warranties is not applicable to you, then such implied warranties shall only remain in effect during the limited warranty period. All determinations of applicability and validity of warranty claims hereunder are solely at the discretion of us and such determination shall be final. THIS LIMITED WARRANTY IS NON-TRANSFERABLE. The limited warranty set forth in this certificate apply only to the product accompanied by this Limited Warranty Certificate. This limited warranty gives you legal rights and you may have other rights which vary from state to state. This limited warranty shall be interpreted in accordance with the laws of the State of Maryland, without regard to provisions concerning conflict of laws. We reserves the right to revise, cancel, or amend its warranties offered to products sold in the future. The limited warranty set forth herein is valid and applicable to the product accompanied by this Warranty Certificate.

WARRANTY CLAIMS PROCEDURE: Should a warranty claim arise, the original purchaser shall contact us for a Warranty Claim Form and Instructions. The original purchaser shall complete the Warranty Claim Form, clearly detailing the defect, and email along with a copy of original sales receipt for the Product to claims@classicbrands.com or as otherwise directed on the Warranty Claim Form. Warranty Claim Forms that are incomplete or sent without a copy of original sales receipt will not be processed and will be returned. Upon receipt by us of the completed Warranty Claim Form and the original sales receipt, our quality control department will verify the defect and/or the applicability of this Limited Warranty thereto. In the event that this Limited Warranty is applicable, a replacement product of equal or greater value will be sent to the customer. The original purchaser will be responsible for shipping, handling and processing fees. No monetary refunds and/or credits will be issued. Please retain this warranty and your original invoice for one (1) year.