

# ASSEMBLY INSTRUCTION

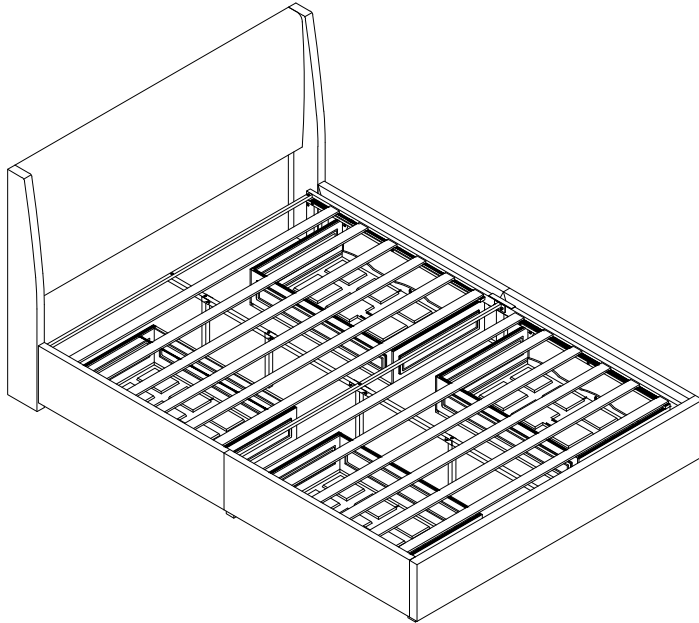

Please **TEAR OFF** this shrink film from side!  
**DO NOT USE CUTTER!**

ITEM NUMBER:BD007

## IMPORTANT NOTE

1. For the protection of your furniture, place all parts on a clean and smooth surface to prevent any damage.
2. Keep fittings out of children's reach and keep children well away from construction area.
3. When moving your assembled bed, it is best to lift the bed and never to drag it.
4. Do not use this product if parts are missing, damaged or worn.
5. This product should only be used on firm, level ground.
6. Please periodically check all fittings and re-tighten as necessary.
7. Do not use the bed unless all bolts and screws are firmly secured.
8. For further assistance, please provide a screenshot of your order and contact us via email at [support@velocavabed.com](mailto:support@velocavabed.com)

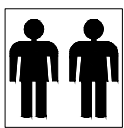

Minimum two  
person assembly

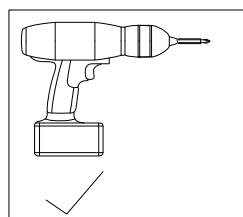



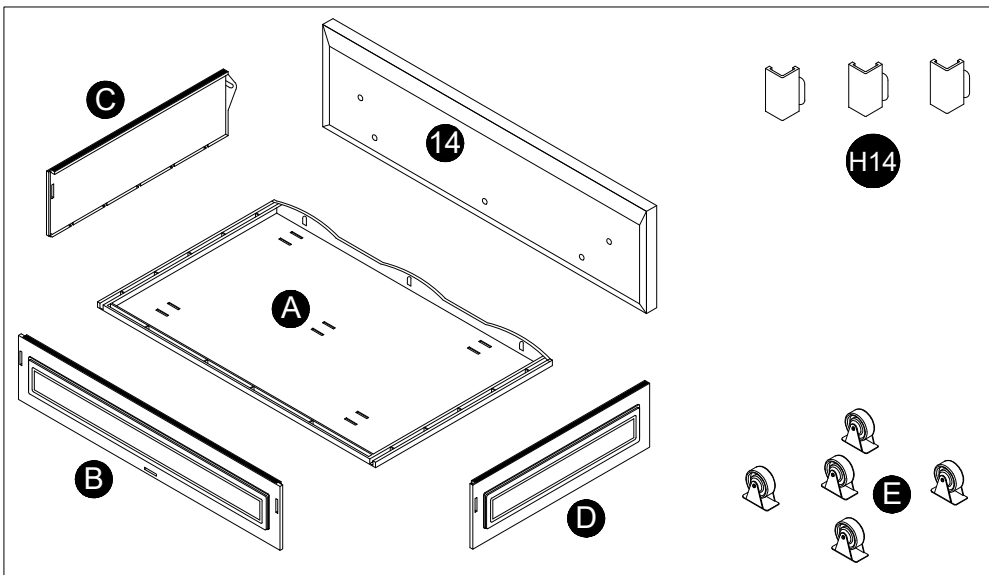
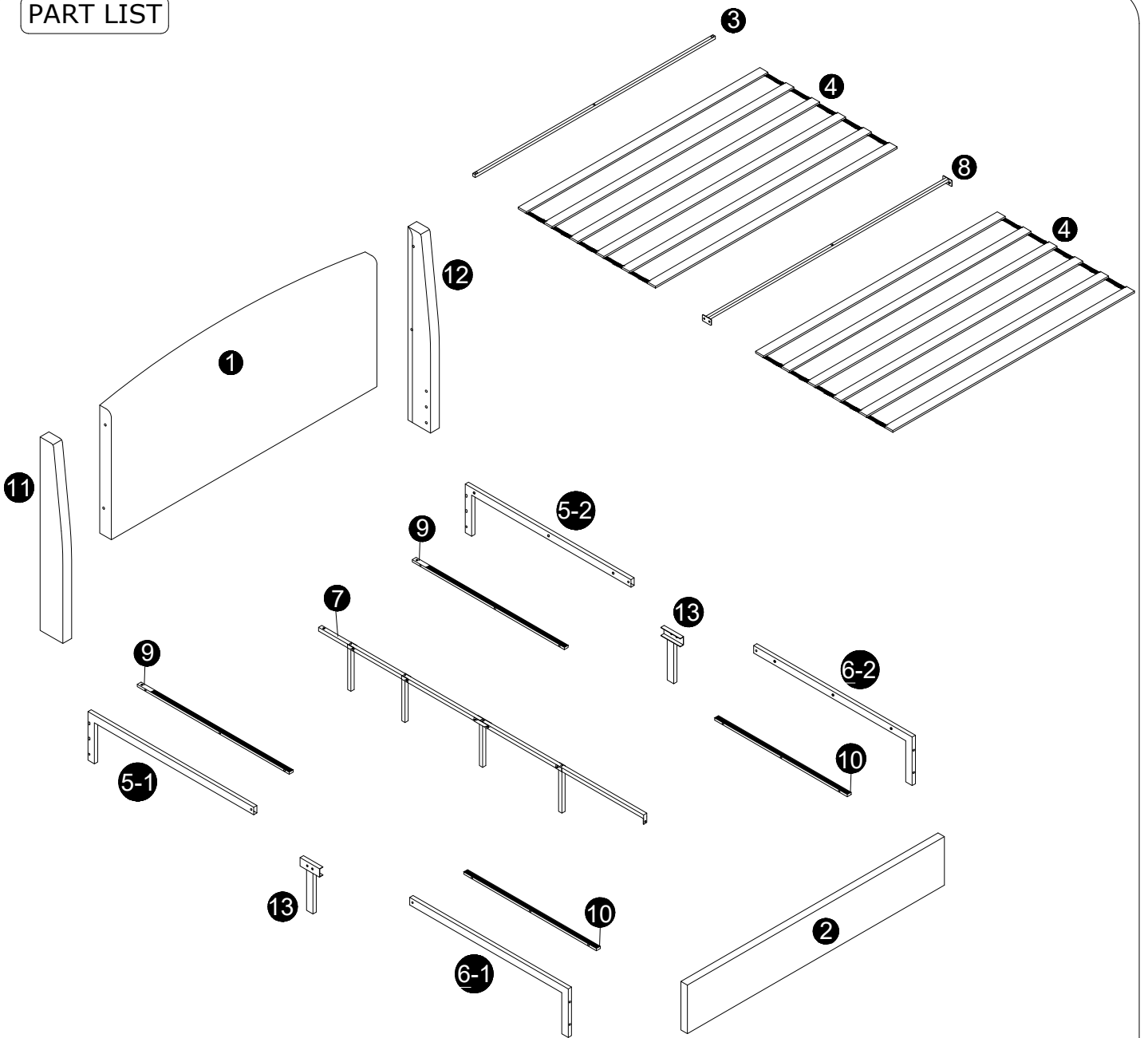



PART LIST

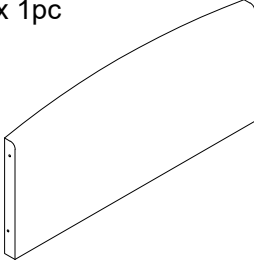
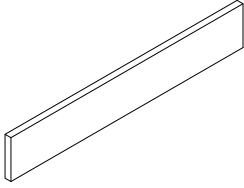
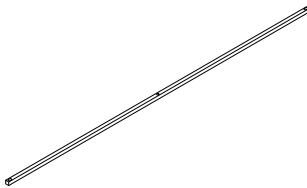
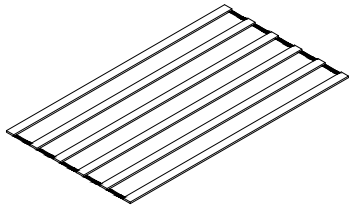
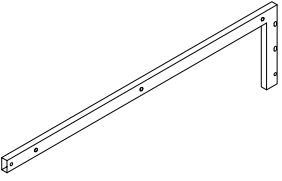
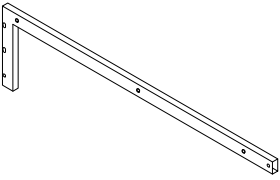
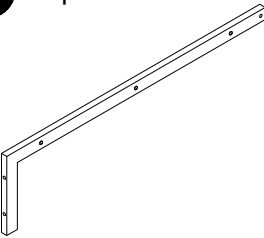
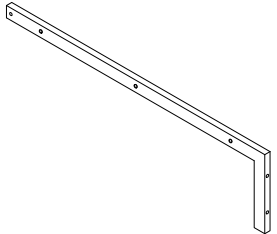
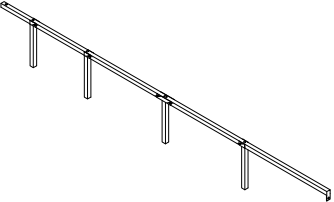
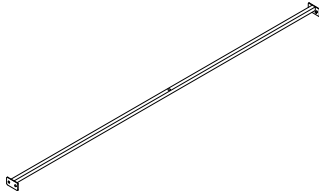
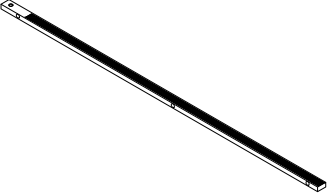

x4

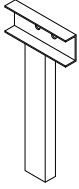
## Components of Carton A





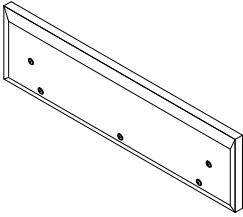
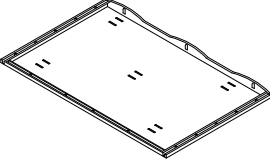
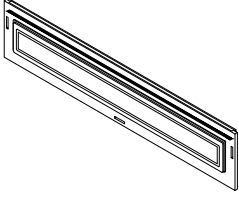
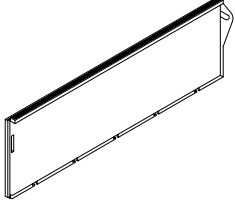
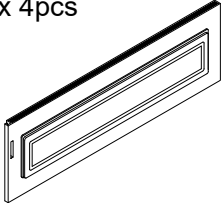



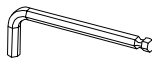

<b>1</b> x 1pc 	<b>2</b> x 1pc 	<b>3</b> x 1pc 	<b>4</b> x 2pcs 	
<b>5-1</b> x 1pc 	<b>5-2</b> x 1pc 	<b>6-1</b> x 1pc 	<b>6-2</b> x 1pc 	
<b>7</b> x 1pc 	<b>8</b> x 1pc 	<b>9</b> x 2pcs 	<b>10</b> x 2pcs 	
<b>11</b> x 1pc 	<b>12</b> x 1pc 	<b>13</b> x 2pcs 	<b>E</b> x 20pcs 	<b>H14</b> x 12pcs 

## Components of Carton B

<b>14</b> x 4pcs 	<b>A</b> x 4pcs 	<b>B</b> x 4pcs 	<b>C</b> x 4pcs 
<b>D</b> x 4pcs 			

Please ensure to thoroughly inspect the small inner cardboard box containing the hardware, which are tied with a red string, before disposing of the box.

HARDWARE LIST

 <b>H1</b> M5 x 1pc	 <b>H2</b> M4 x 1pc	 <b>H3</b> M8x30mm x 4pcs	 <b>H4</b> M8x40mm x 22pcs
 <b>H5</b> M8 x 4pcs	 <b>H6</b> M8x22mm x 4pcs	 <b>H7</b> M8x60mm x 4pcs	 <b>H8</b> M6x35mm x 7pcs
 <b>H9</b> M6x60mm x 1pc	 <b>H10</b> M6x15mm x 20pcs		

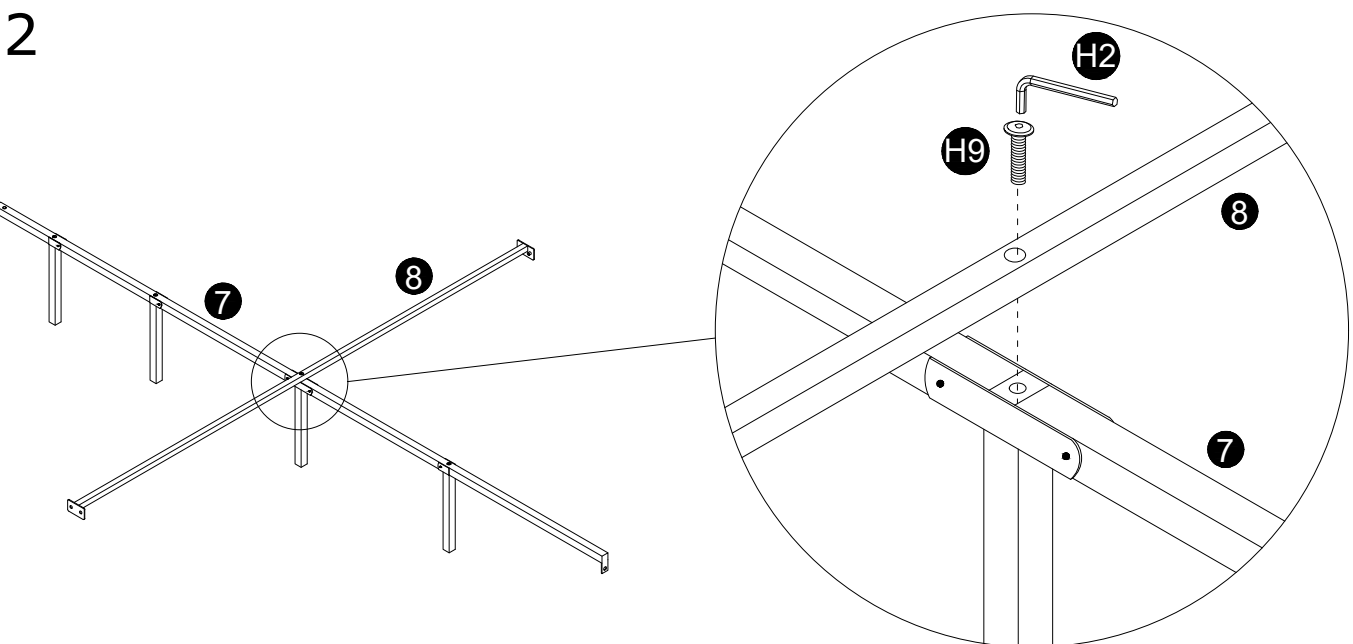
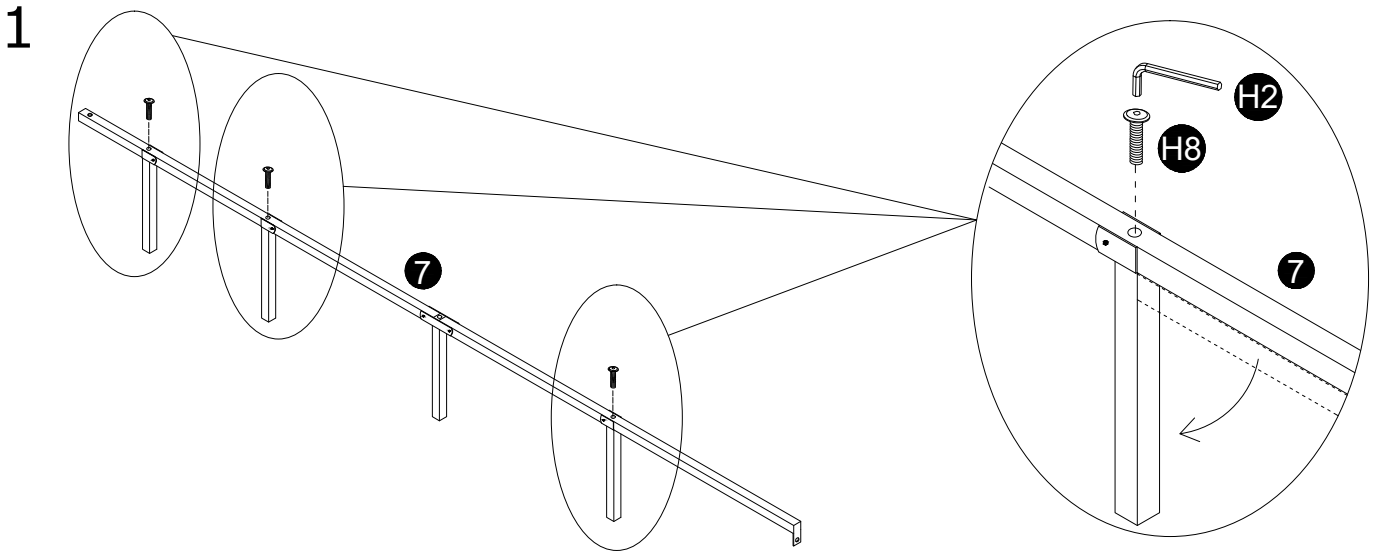

3

Please attention when assembling the part number 8, please first pass the part number 5-1 /5-2/6-1/6-2 through the part number 13 and the alignment hole, and then connect the part number 8 to the alignment hole assembly.

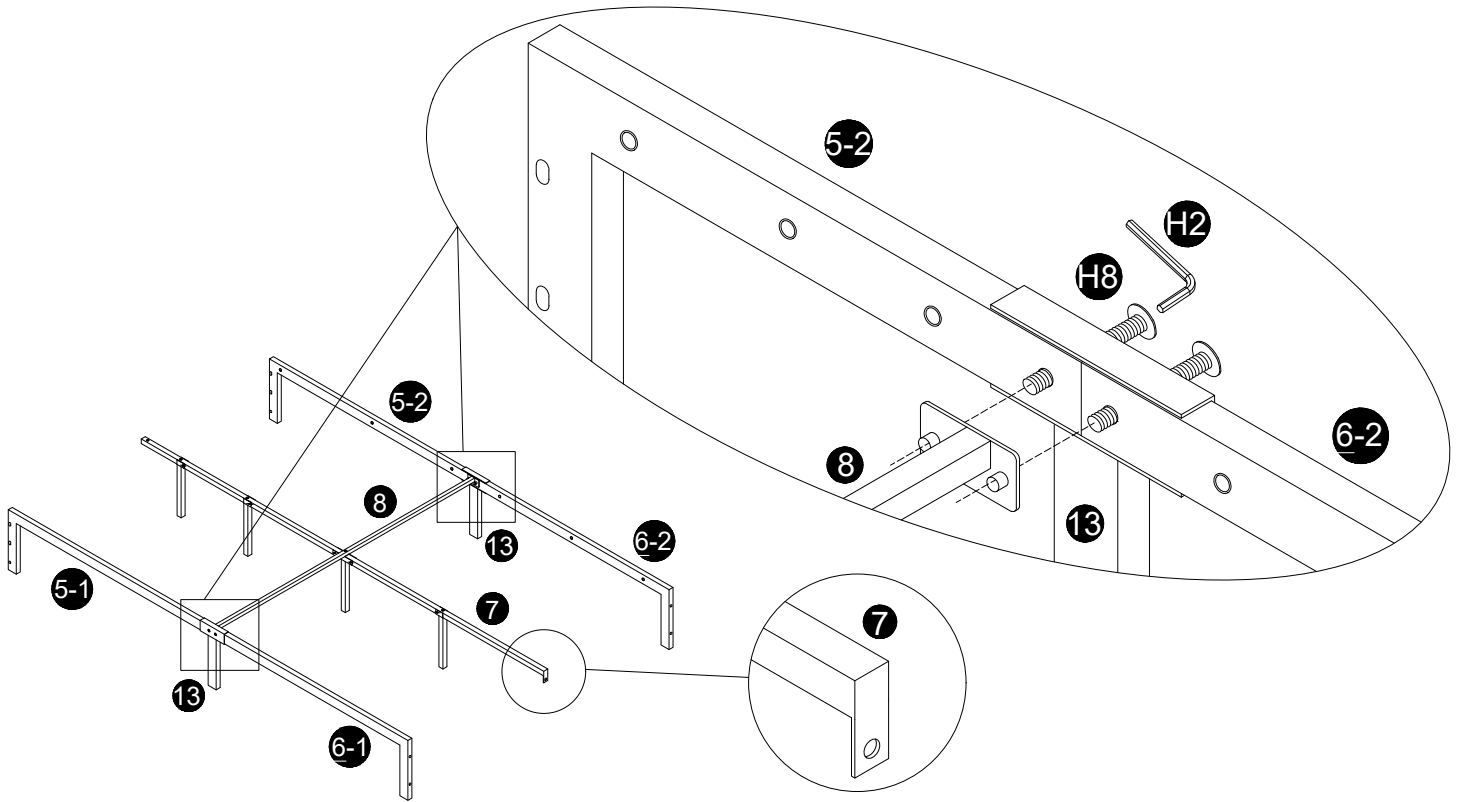

4

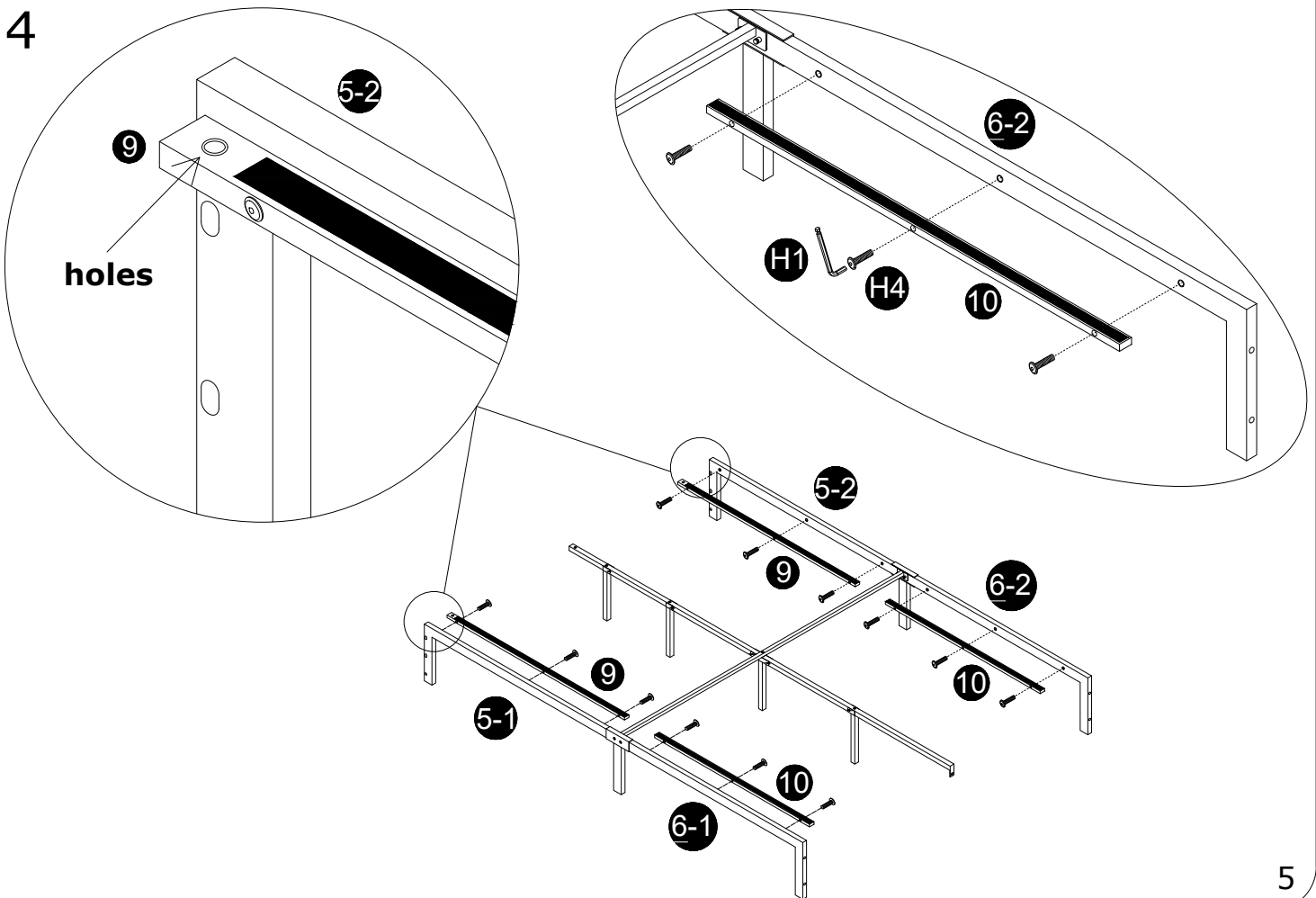

5

As shown in the diagram, align the screws with the corresponding holes and pre-fix them. Then, tighten each screw separately.

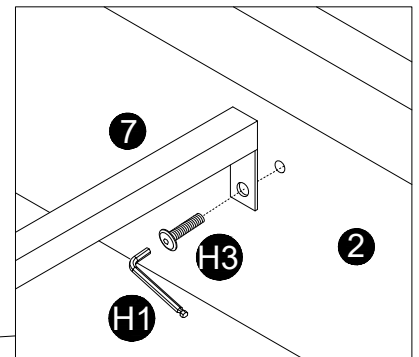
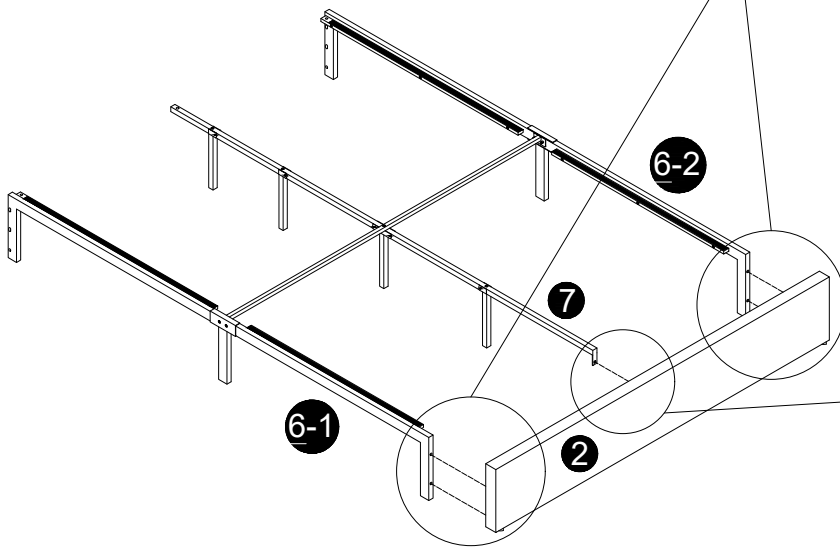
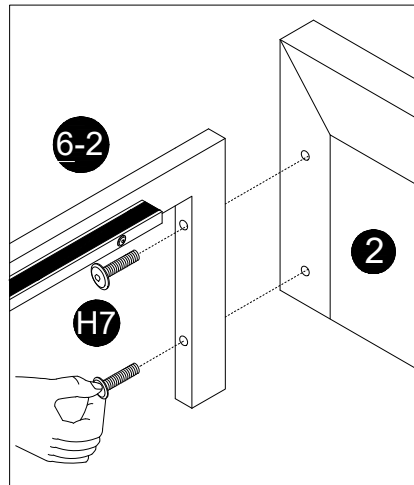

Please fully tighten step 5 all fixings before go to next step.

6

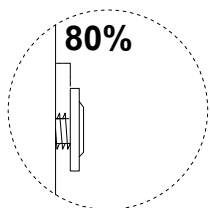
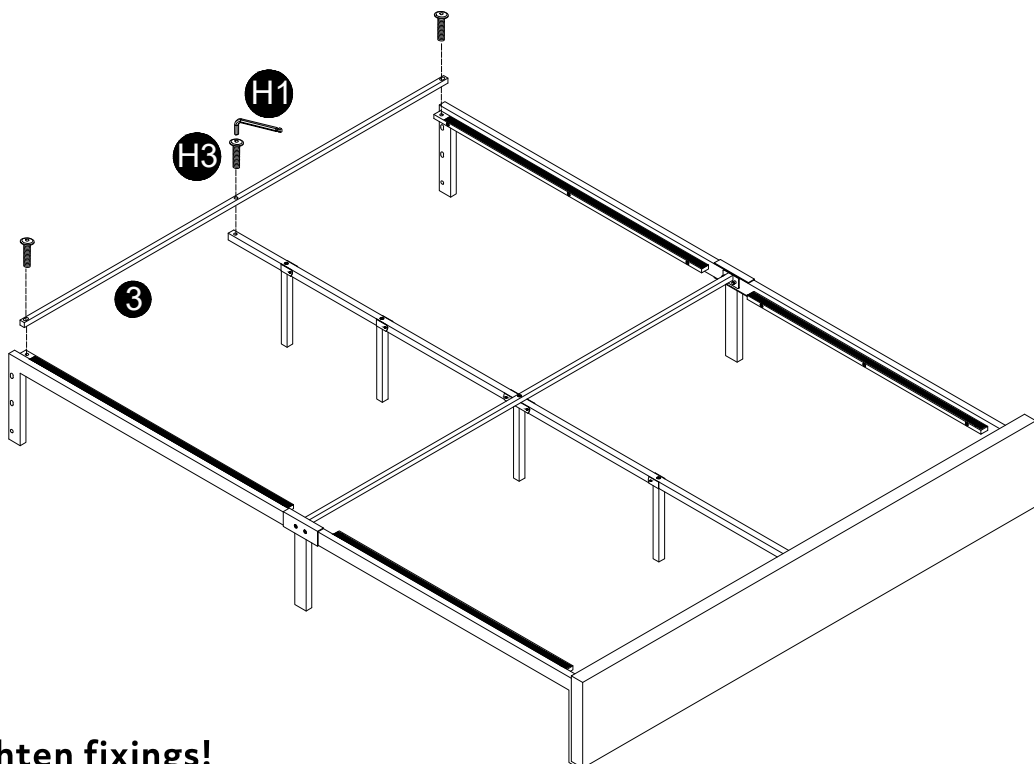

Do not fully tighten fixings!

7

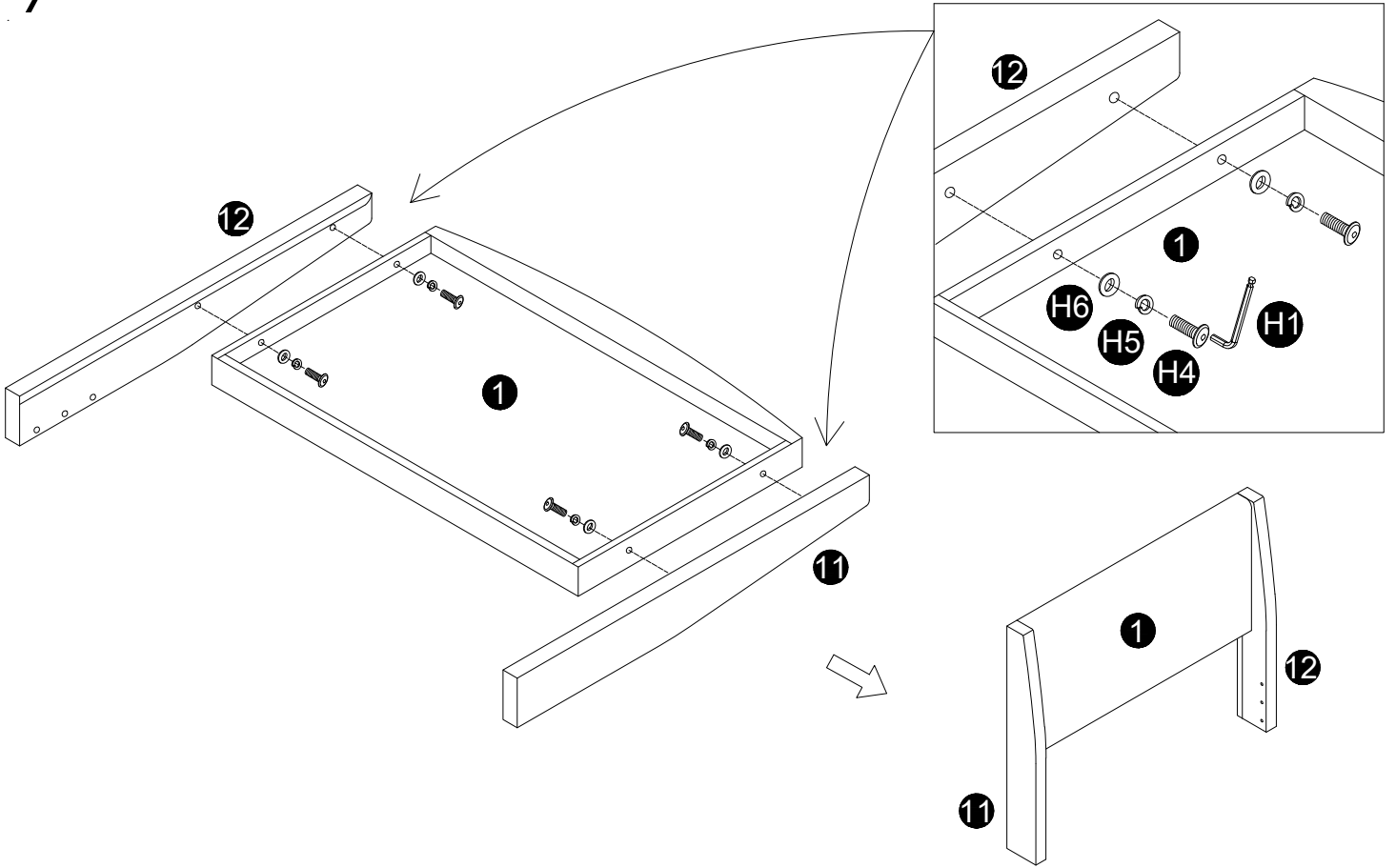

8

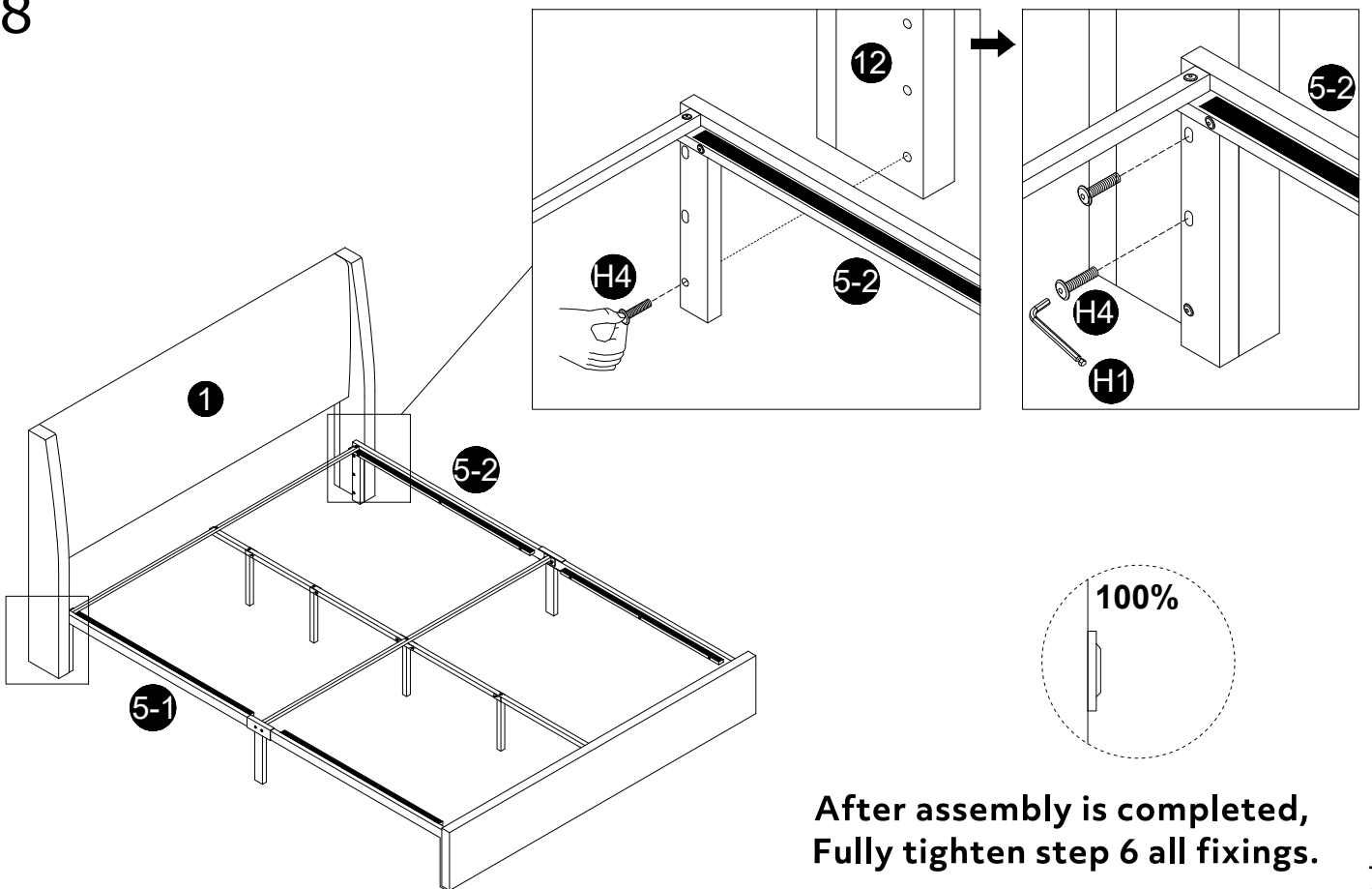

9

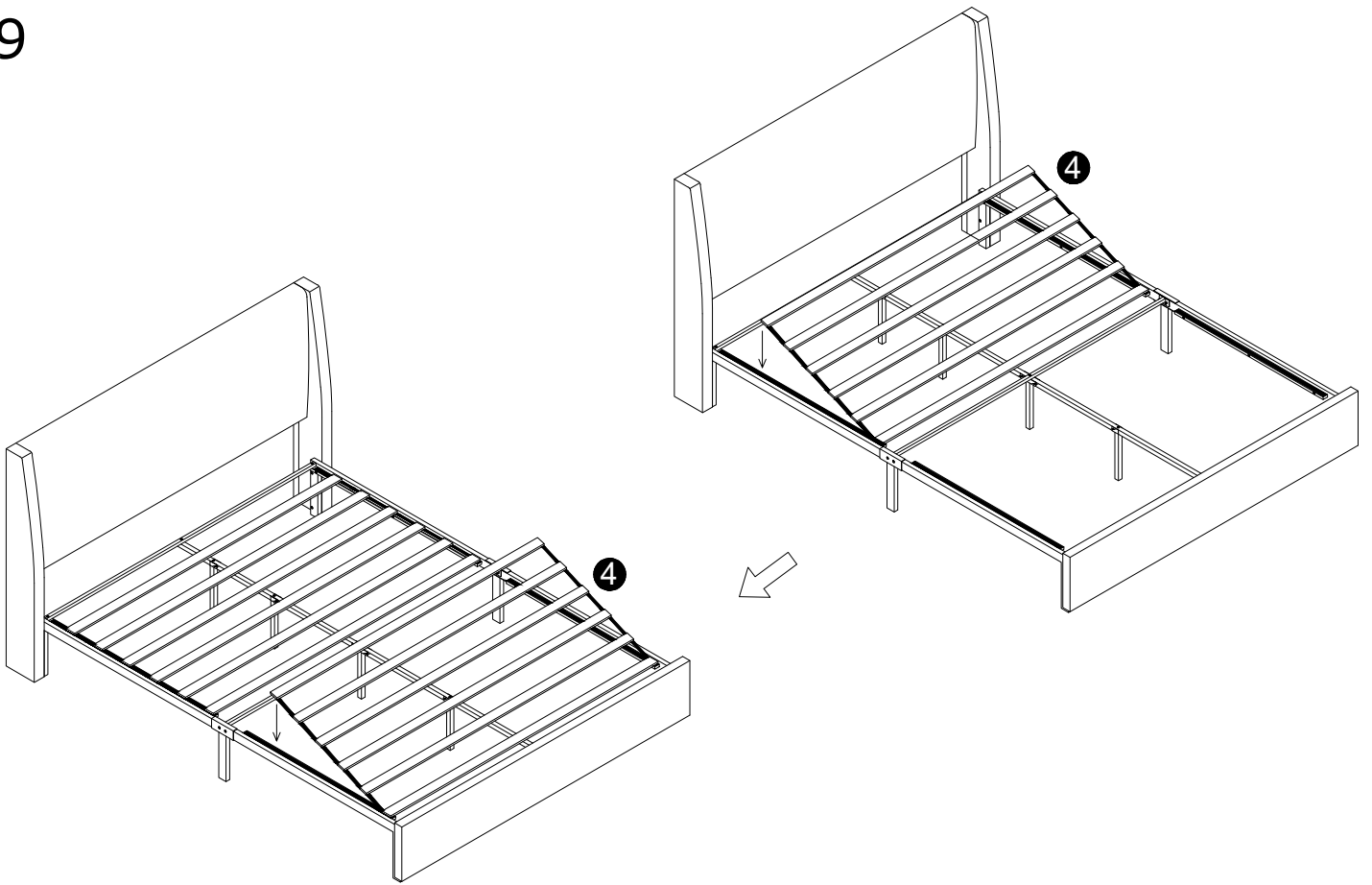

10 Put plastic baseboard (A) flat on the floor, assemble side baffles (C&D), following the assemble picture aligning them inward, ensuring all fit into all slots, and push forcefully until the side panels are flush with the baseboard.

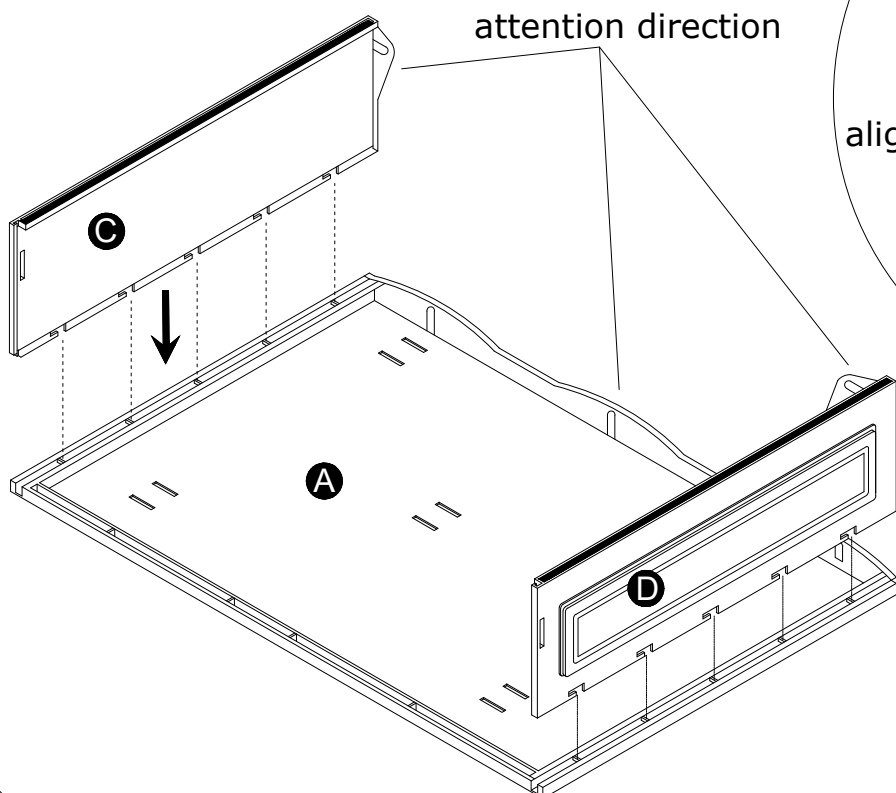

11

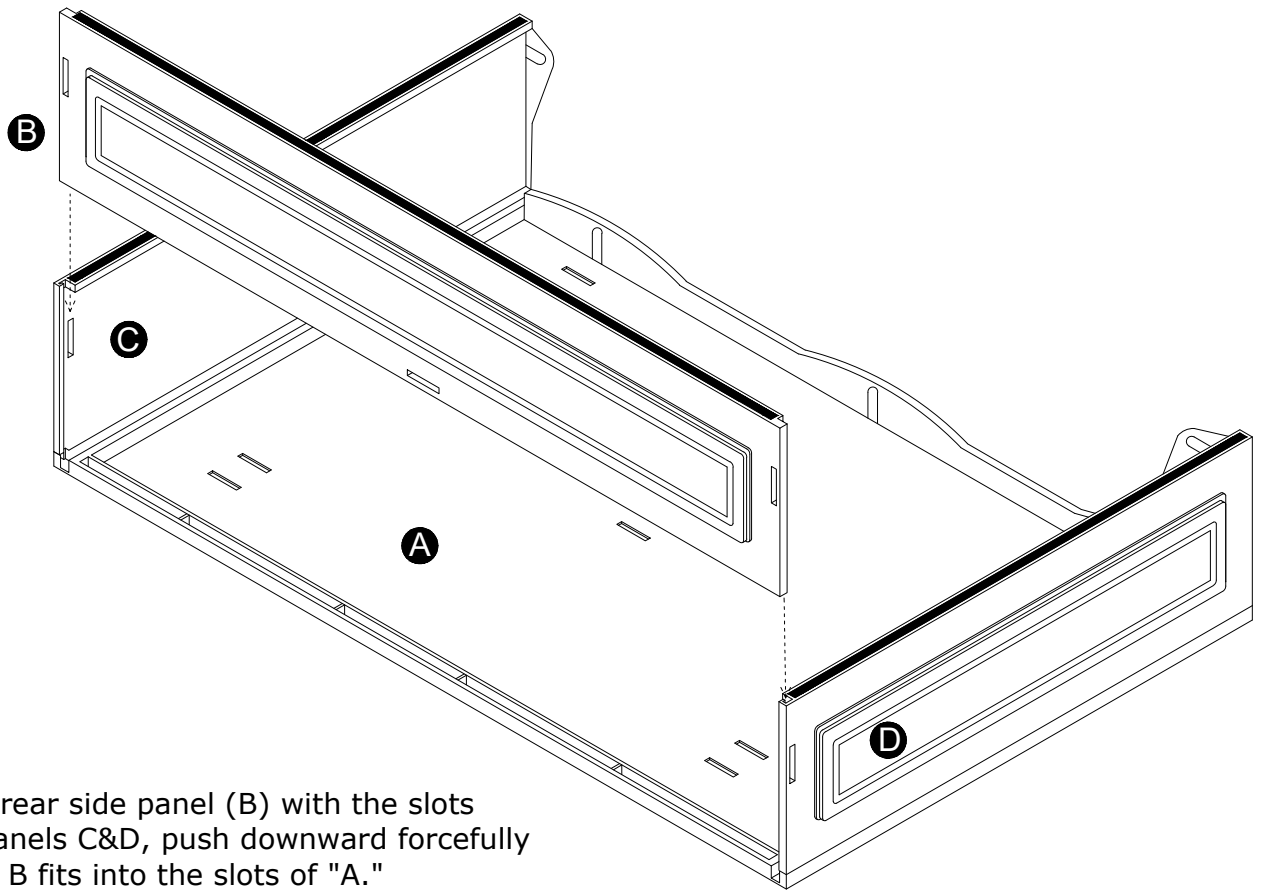

Align the rear side panel (B) with the slots on side panels C&D, push downward forcefully to ensure B fits into the slots of "A."

12 Take clip H14 and secure side panels D&B, B&C, and A&B, ensure the clips fully engage with the slots.

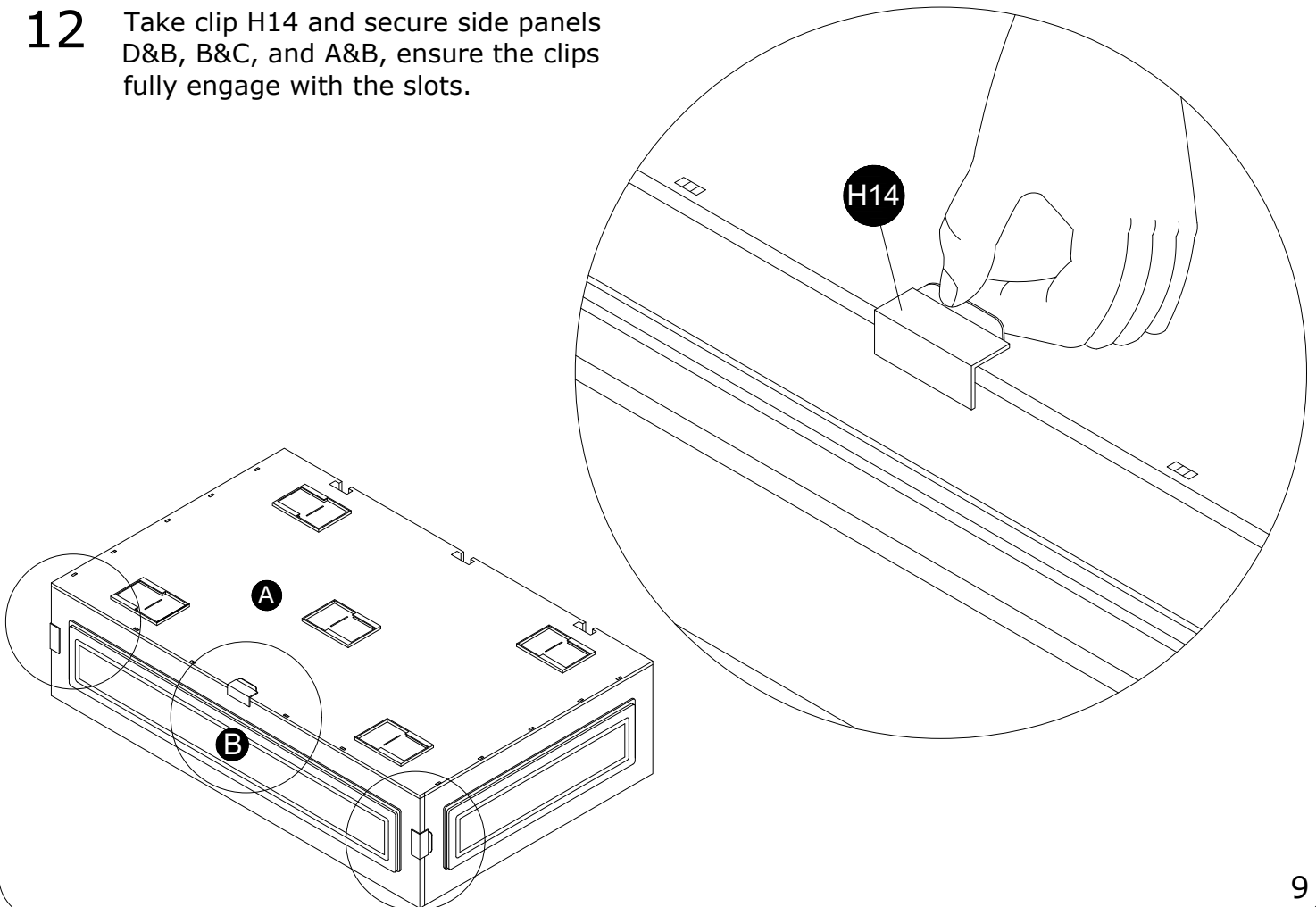

- 13** Install wheels "E" by forcefully pushing them into the slots; once pushed to the bottom, a protrusion will engage with the metal sheet to prevent them from easily coming off. All five part "E" wheels need to be installed correctly.

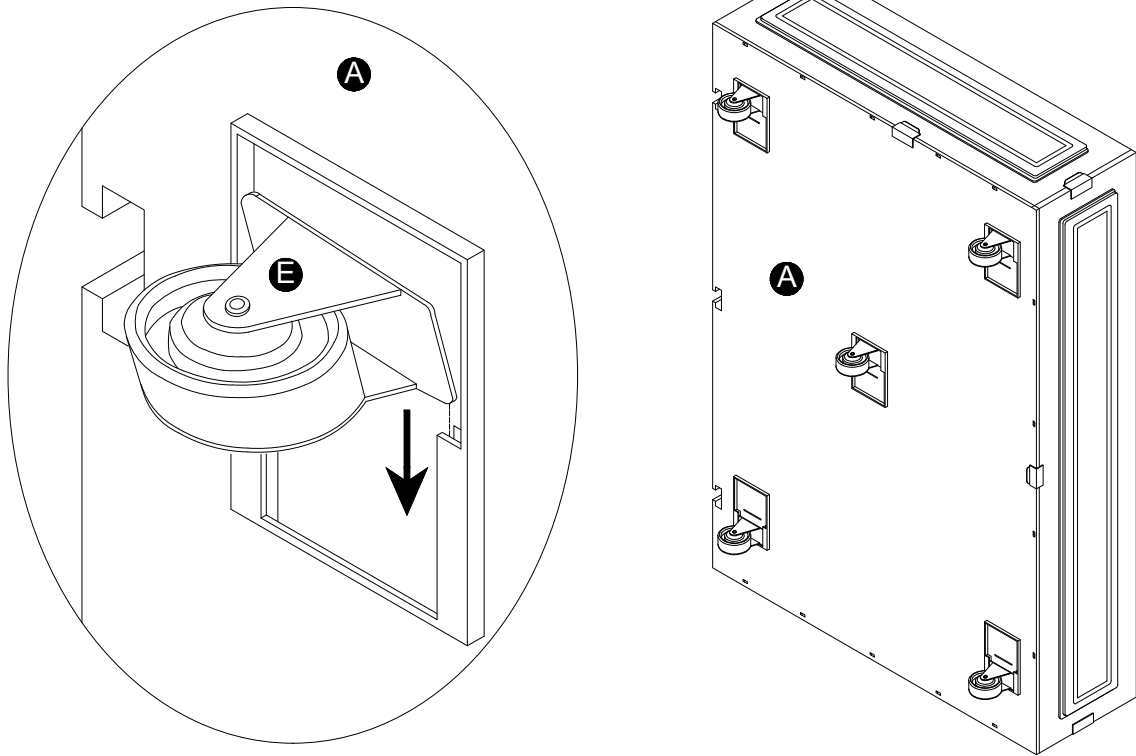

- 14** Take screw H10, first install it into drawer panel 14, then screw in the bottom 3 screws partially leaving them protruding 8mm (for easy installation). Insert the drawer bottom A into the three screws of the panel, ensuring no distortion of the drawer and panel to prevent plastic parts from breaking during installation.

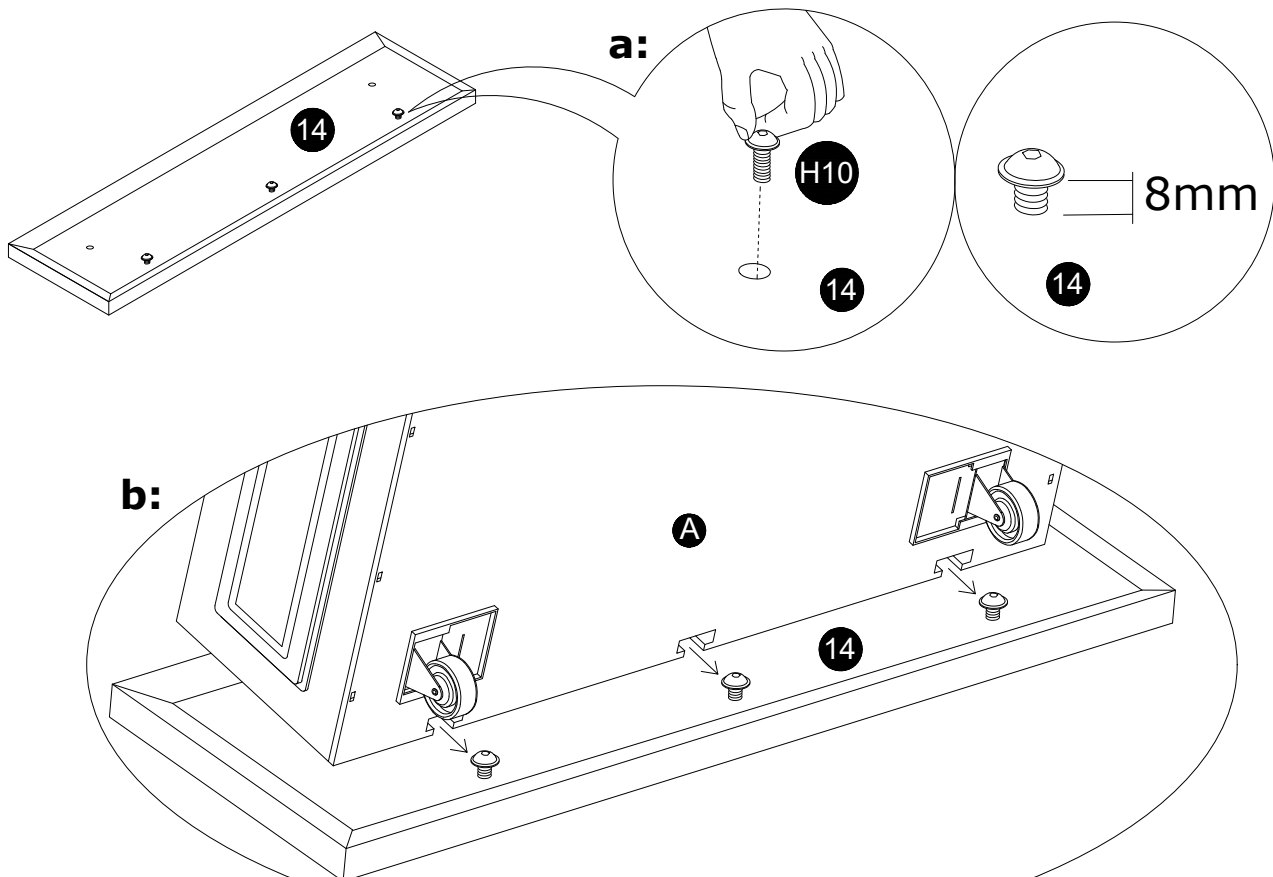

15

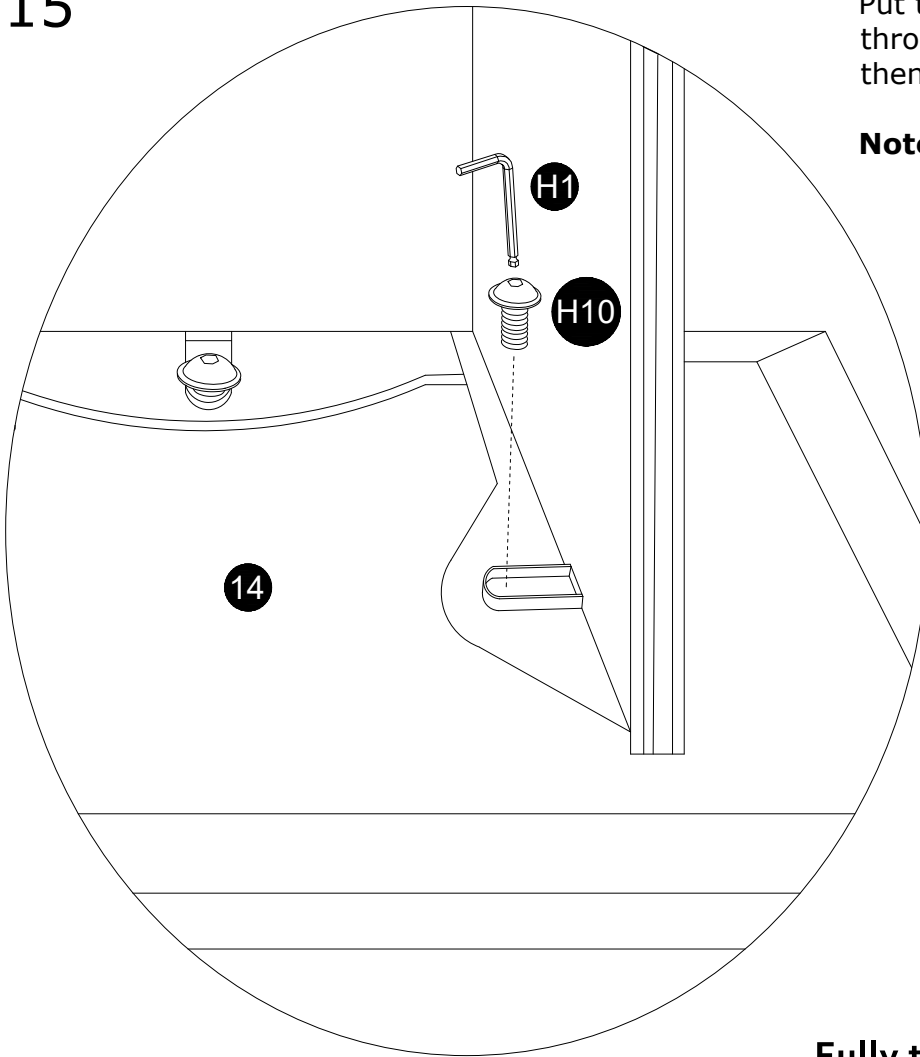

Put the drawer flat, install screw H10 through the holes in drawer sides C&D, then tighten all screws.

**Note:** Plastic drawers should not be installed with power tools; tightening manually is sufficient.

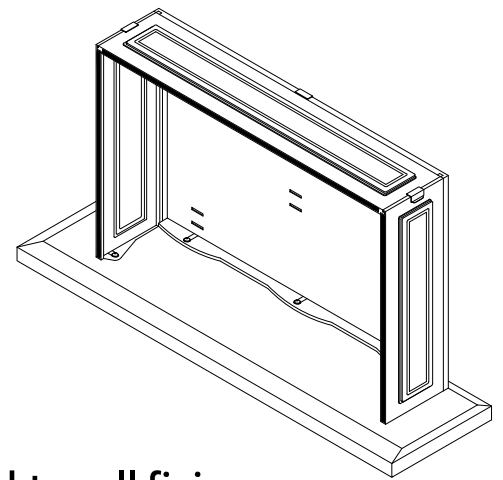

**Fully tighten all fixings.**

16

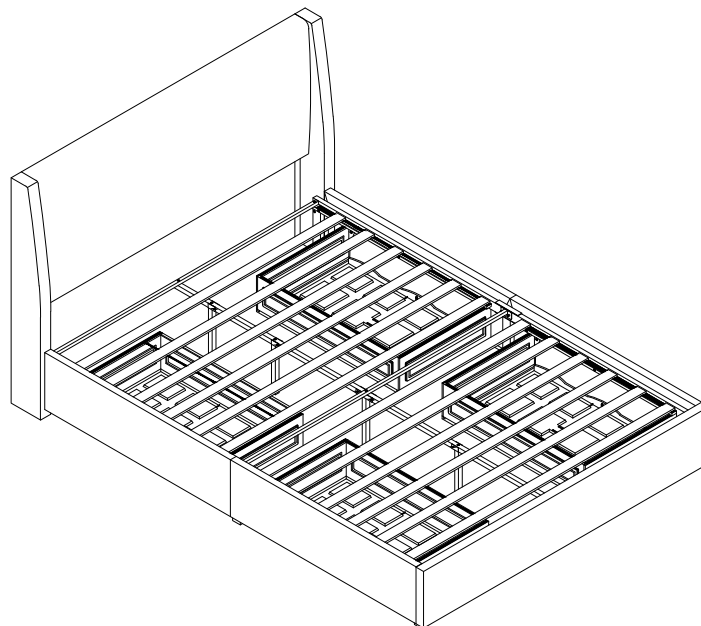

**Job Complete !**

*In the interest of our environment please dispose of all packaging thoughtfully.*