

**IMPORTANT
RETAIN FOR FUTURE REFERENCE
READ CAREFULLY**

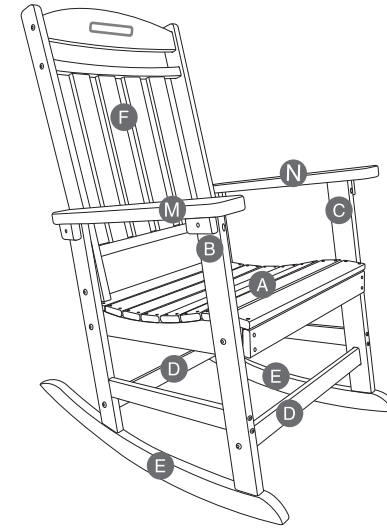



Assembly Instructions





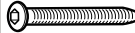
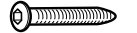

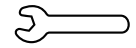
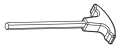

Note:

1. Do not use electric screwdriver.
2. Two people are required to assemble this item. Assemble the item on a flat, solid and even surface.
3. Make sure that all the necessary parts are in the carton before starting the assembly.
4. Please secure all parts and bolts loosely, only when the frame is complete should you fully tighten the screws.
5. If any instability occurs, loosen the screws, re-align the components as necessary and re-tighten the screws evenly.
6. This item is not a climbing frame or toy.
7. Danger of suffocation. Keep out of reach of children.

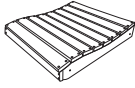
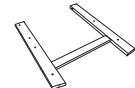
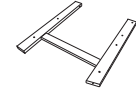
Hardware List

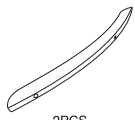
<p>1</p> <p>M6x100mm Screw</p>  <p>4PCS</p>	<p>2</p> <p>M6x50mm Screw</p>  <p>4PCS</p>	<p>3</p> <p>M6x85mm Bolt</p>  <p>2PCS</p>	<p>4</p> <p>M6x60mm Bolt</p>  <p>8PCS</p>
<p>5</p> <p>M6 WASHER</p>  <p>10PCS</p>	<p>6</p> <p>M6 NUT</p>  <p>10PCS</p>	<p>7</p> <p>No.10 Spanner</p>  <p>1PC</p>	<p>8</p> <p>S4 Allen key</p>  <p>1PC</p>

Parts List

<p>A</p> <p>Chair Seat</p>  <p>1PC</p>	<p>B</p> <p>Right Chair Leg</p>  <p>1PC</p>	<p>C</p> <p>Left Chair Leg</p>  <p>1PC</p>	<p>D</p> <p>Front&Back Rail</p>  <p>2PCS</p>
<p>E</p> <p>Rheboscelia</p>  <p>2PCS</p>	<p>F</p> <p>Chair Backrest</p>  <p>1PC</p>	<p>M</p> <p>Right Armrest</p>  <p>1PC</p>	<p>N</p> <p>Left Armrest</p>  <p>1PC</p>

Assembly

Step 1: Attach **Part B** (Right chair leg) to **Part A** (Chair Seat), Repeat **Part C** (left chair leg) operation on the other side. Using **Hardware** (M6*60mm Bolt), **Hardware** (M6 Washer) and **Hardware** (M6 Nut).

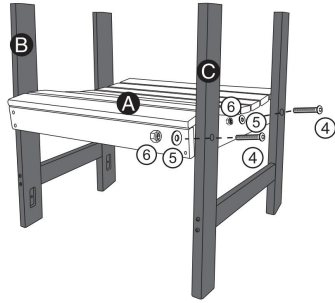

Step 2: Connect **Part D** (Front&back rail) to **Part B** (Right chair leg) and **Part C** (left chair leg). Using **Hardware** (M6 x 50mm Screw).

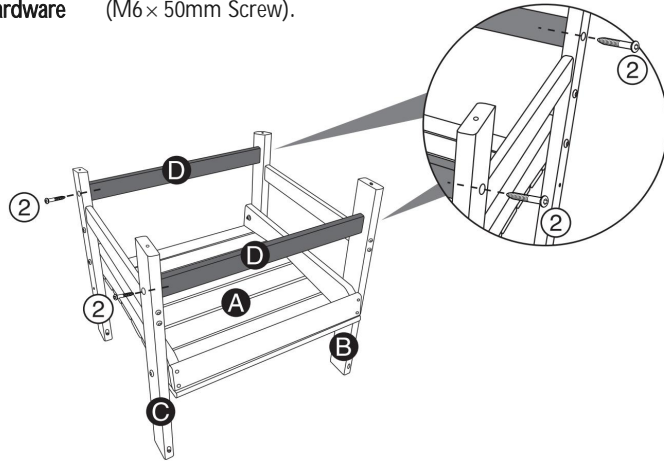

Step 3: Put **Part E** (Rheboscilia) onto the chair legs and secure with **Hardware** (M6 x 100mm Screw).

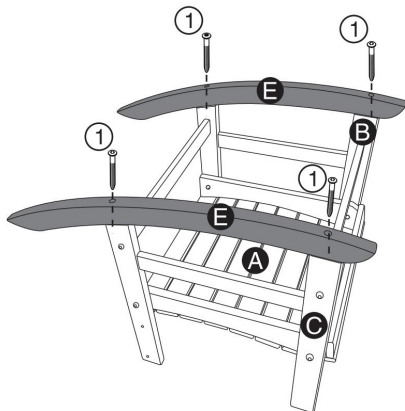

Step 4: Secure **Part M** (Right Armrest) to **Part B** (Right Chair Leg). Secure **Part N** (Left Armrest) to **Part C** (Left Chair Leg). Using **Hardware** (M6 x 60mm Bolt), **Hardware** (M6 Washer) and **Hardware** (M6 Nut).

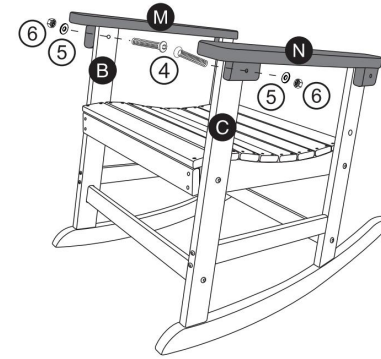

Step 5: Insert **Part F** (chair backrest) into chair arm, using **Hardware** (M6 x 85mm Bolt), **Hardware** (M6 x 60mm Bolt), **Hardware** (M6 Washer) and **Hardware** (M6 Nut). After this step, please fully tighten all bolts if you check all the parts are positioned. Assembly is complete.

