

NOTICE

- * Please make sure that you have all parts indicated and they are in good condition before you begin assembly of this item. Refer to part list and hardware list below for guidance.
- * This item should be assembled on a soft surface to prevent scratching the finish during assembly.
- * This item may require periodic tightening.
- * If you are having difficulty, our friendly Customer Care team is always here to help. Please email customersupport@safavieh.com

PREPARATION

- * Before beginning assembly of product, make sure all parts are present. Compare parts with part contents list and hardware contents list.
- * If any part is missing or damaged, do not attempt to assemble the product.
- * Estimated Assembly Time: 10 minutes.
- * Tools Required for Assembly (included): Allen wrench.

CARE AND MAINTENANCE

Adhesive felt pads should always be applied to areas of furniture which make direct contact with flooring, said application will prevent damage to the furniture and or surfaces on which the furniture lies. Objects placed on articles of furniture should rest on non abrasive material as to prevent damage to the wood finish. Objects whose composition consist of plastic and rubber are known to discolor and damage the wood surfaces on which they rest. Wipe up spills immediately and avoid common hazards such as hot dishes, harsh solvents and abrasives. Cleaning should be done with a soft lint free cotton cloth dampened with water or furniture polish. On highly used surfaces we recommend applying a quality paste wax which should be used on a regular basis to provide additional protection from scratches and spills. How often you apply the wax depends on how much the furniture wears.

SAFAVIEH FURNITURE

ITEM ID: DCH8510A

PRODUCT DIMENSION: 19.3" W X 20.8" D X 39" H

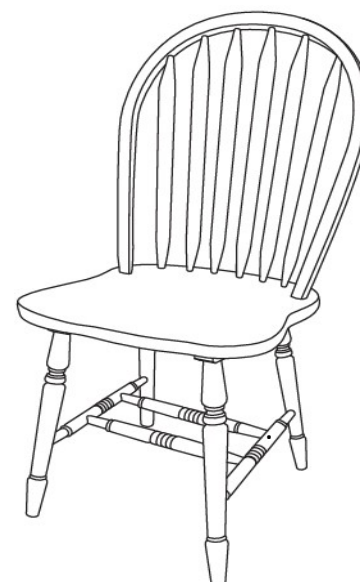











Weight Capacity: 225LBS

WARNING: DO NOT STAND ON CHAIR

WARNING: DO NOT ROCK BACK AND FORTH OR SIDE TO SIDE ON CHAIR

Part List and Hardware List

PIECE	DESCRIPTION	PICTURE	QUANTITY
A	BACK REST		1X
B	LEFT LEG FRAME		1X
C	RIGHT LEG FRAME		1X
D	FRONT STRETCHER		1X
E	BACK STRETCHER (HOLE)		1X

PIECE	DESCRIPTION	PICTURE	QUANTITY
HW1	JCBC BOLT M6 X 50MM		2X
HW2	BARREL NUT M6 X 13MM		2X
HW3	SCREW M7 X 35MM		6X
HW4	ALLEN WRENCH M4		1X
HW5	WOOD PLUG		2X

PREPARATION

- * Before beginning assembly of product, make sure all parts are present. Compare parts with part contents list and hardware contents list.
- * If any part is missing or damaged, do not attempt to assemble the product.
- * Estimated Assembly Time: 10 minutes.
- * Tools Required for Assembly (included): Allen wrench.
- * If you are having difficulty, our friendly Customer Care team is always here to help. Please email customersupport@safavieh.com

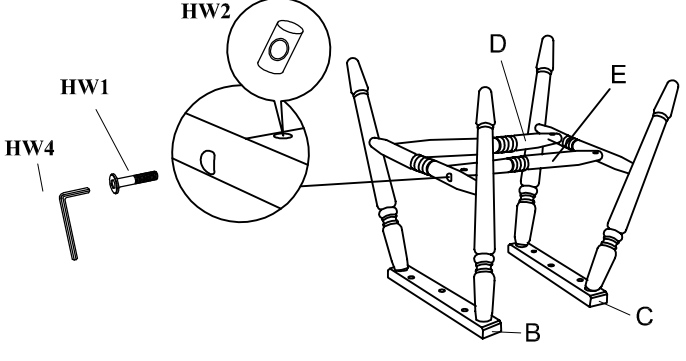
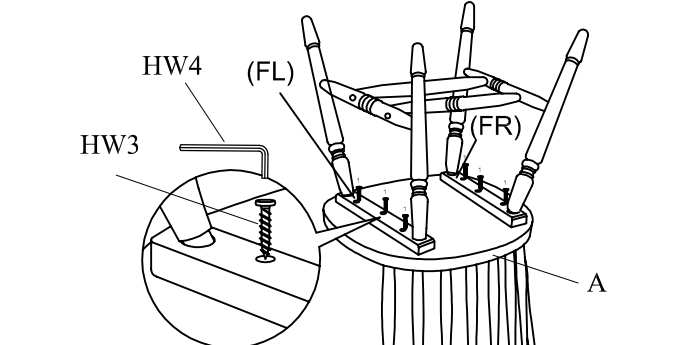
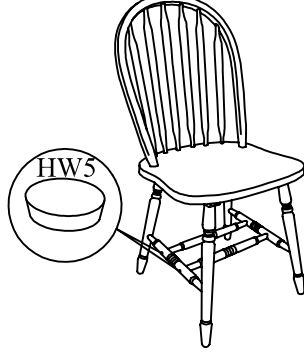
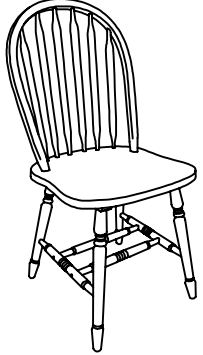
		
<p>Step 1: Gather the left Leg Frame (B) and Right Leg Frame (C). Position the Front Stretcher (D) and Back Stretcher (Hole) (E) between them. Insert Barrel Nuts (HW2) into the holes on the Stretcher (E). Align the holes on the leg frames with the Stretcher and insert JCBC Bolts (HW1) through the leg frames into the Barrel Nuts. Use the Allen Wrench (HW4) to loosely secure the bolts. Do not fully tighten yet.</p>	<p>Step 2: Attach the Back Rest (A) to the top of the leg frame using Screws (HW3). Ensure all Screws from Steps 1-3 are tightened securely, but do not overtighten-tighten until snug to avoid damage.</p>	<p>Step 3: After confirming that all screws are securely tightened from Steps 1 and 2, locate the visible screw holes on the outer face of the Stretcher (D). Gently press the Wood Plugs (HW5) into these holes until flush with the surface.</p>
		
<p>Step 4: Ensure the following before use.</p> <ol style="list-style-type: none"> 1) Screws tightened. 2) Chair sits level. 3) No gaps in joints. 4) All plugs inserted. 		