

ASSEMBLY INSTRUCTION

MADE IN VIETNAM

Thank you for purchasing this quality product. Be sure to check all packing materials carefully for small parts that may have come loose inside the carton during shipment.

Before you start assembly: Please read all instructions carefully before beginning the assembly process. It is recommended that 2 people work together during assembly to prevent personal injury and to ensure that heavy or cumbersome parts are not damaged during the process.

CAUTION: For your safety, this product requires two people to lift

Assembled Dimensions

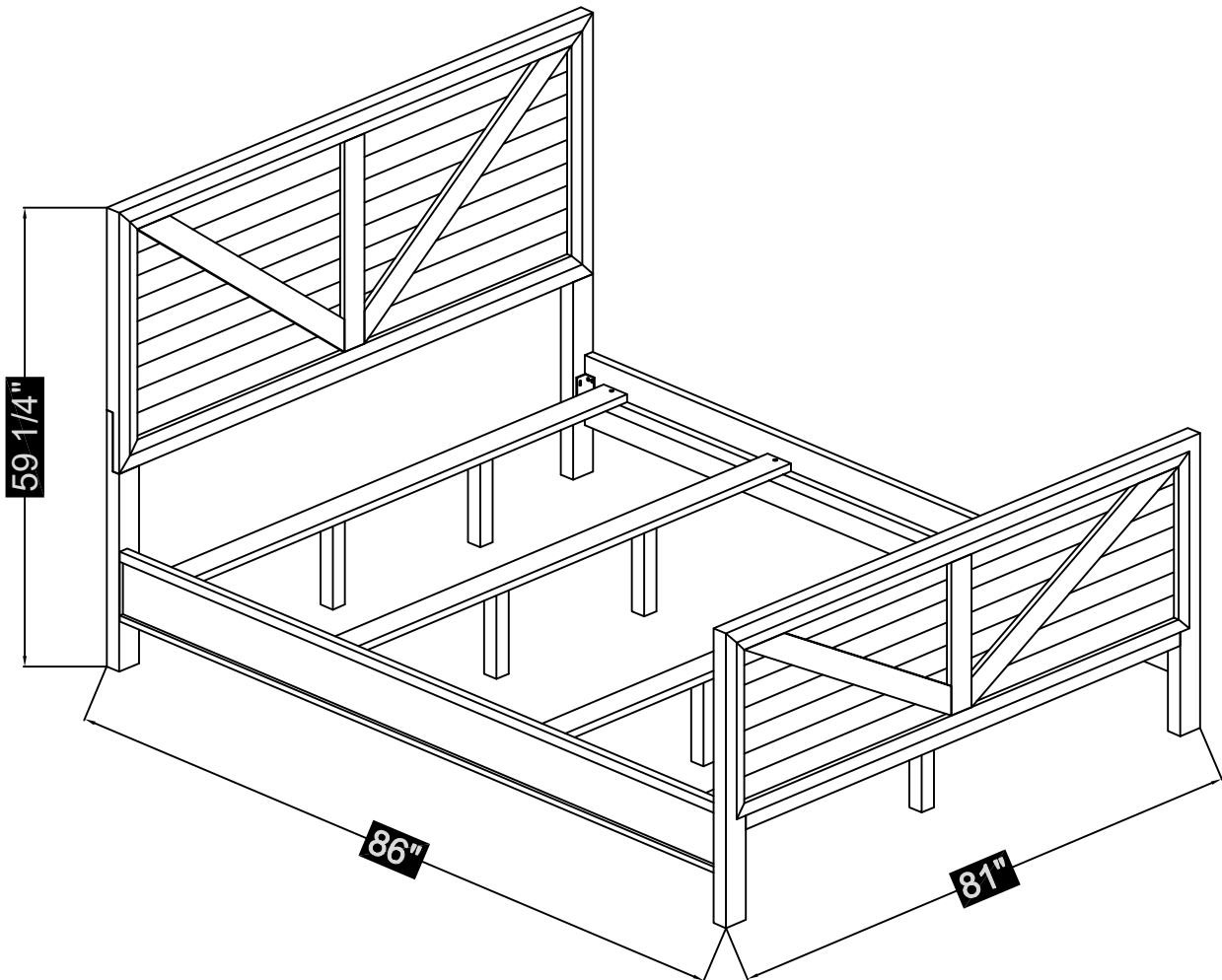

0.5 hr

APPROXIMATE ASSEMBLY TIME

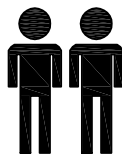

2 PERSONS

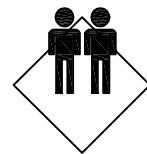

REQUIRED ASSEMBLY SPACE

REQUIRED ASSEMBLY TOOLS

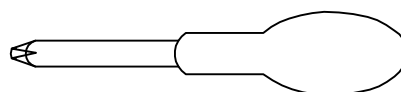





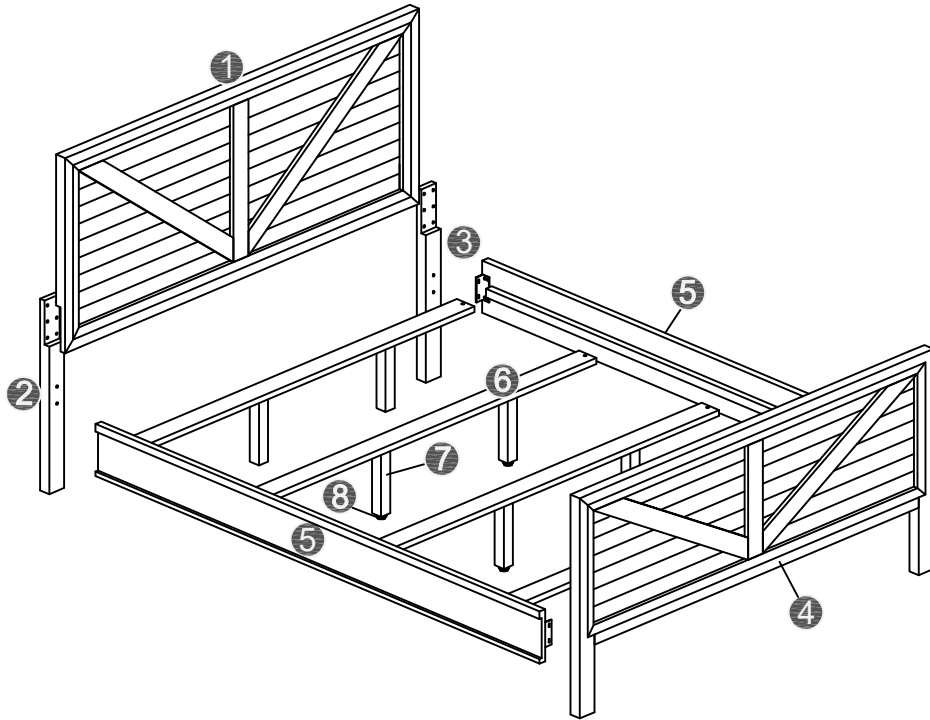

NOT PROVIDED

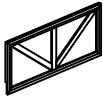
ASSEMBLY INSTRUCTION

PART LIST



NO.		PART LIST	QTY
(1)		HEADBOARD	1
(2)		HEADBOARD LEG(LEFT)	1
(3)		HEADBOARD LEG(RIGHT)	1
(4)		FOOTBOARD	1
(5)		SIDE RAIL	2
(6)		SLAT	4
(7)		SLATS SUPPORT	8
(8)		LEVELER	8

ASSEMBLY INSTRUCTION

HARDWARE LIST

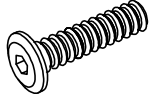

8x
5/16" x 40mm
A
BOLT

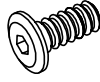

16x
5/16" x 25mm
B
BOLT

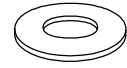

24x
5/16" x 19x 1.5mm
C
FLAT WASHER



24x
5/16" x 13 x 1mm
D
SPRING WASHER

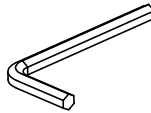

1x
M4x60mm
E
ALLEN KEY



1x
M4x76mm
F
STRAIGHT ALLEN KEY

ASSEMBLY INSTRUCTION

STEP 1

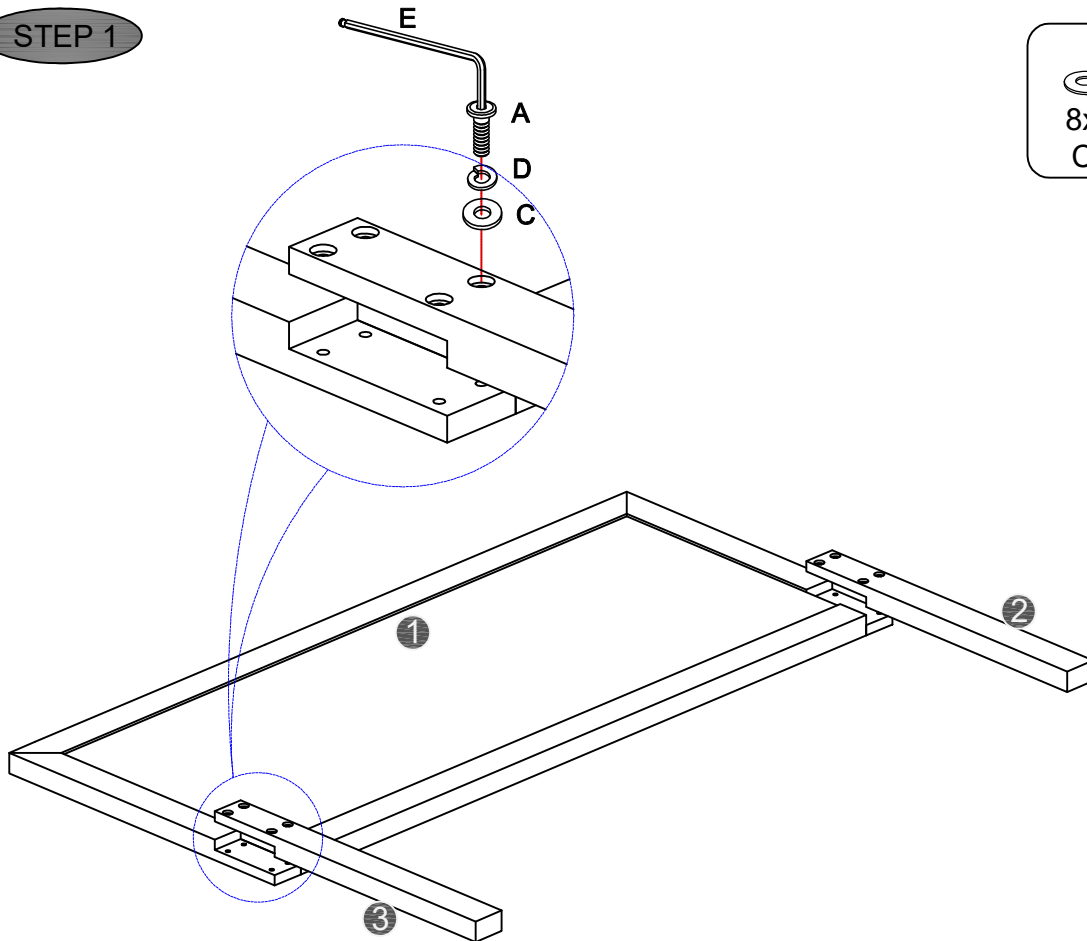



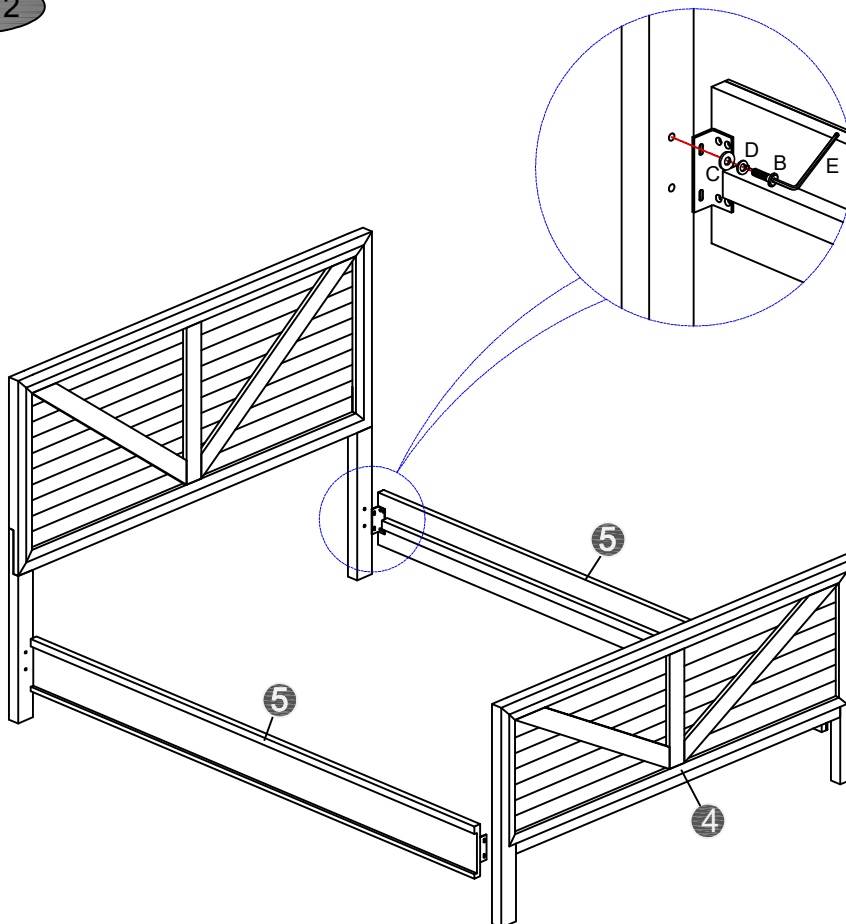

STEP 2



ASSEMBLY INSTRUCTION

STEP 3

			
8x	8x	8x	1x
C	D	B	E

