









Nesting Tables

Examine all packaging material for small parts that may have come loose during shipment. Periodic checks are recommended to insure that all components are in proper position, tight and free from damage. Keep this assembly instruction for future reference. Adult assembly is required.

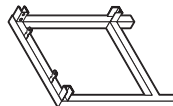
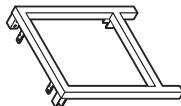
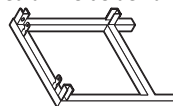
CODE	QTY	HARDWARE
1	12	Adjustable Feet 
2	38	1/4"x 15mm Allen Bolts 
3	38	1/4" Spring Washers 
4	38	1/4" Flat Washers 
5	1	Allen Wrench 

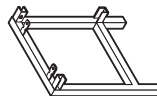
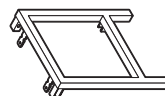
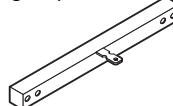
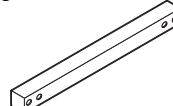
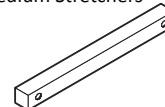
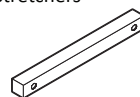
CODE	QTY	COMPONENTS	CODE	QTY	COMPONENTS
A	1	Large Left Side Panel 	B	1	Large Right Side Panel 
C	1	Medium Left Side Panel 	D	1	Medium Right Side Panel 
E	1	Small Left Side Panel 	F	1	Small Right Side Panel 
G	2	Large Top Stretchers 	H	1	Large Bottom Stretcher 
I	3	Medium Stretchers 	J	3	Small Stretchers 
M	1	Large Top 	N	1	Medium Top 
			O	1	Small Top 

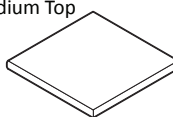
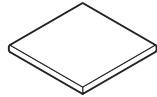
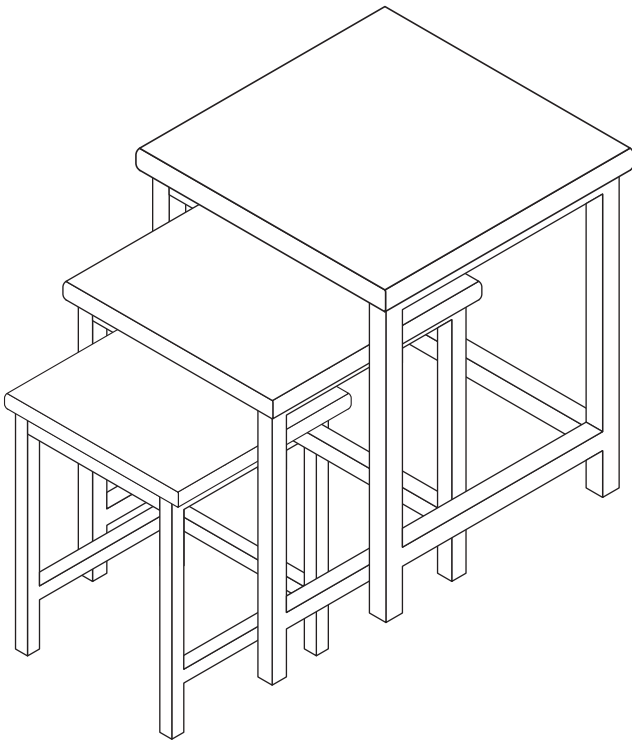

WARNING

- Do not let any sharp objects touch or rub the surface of the product.
- When assembling, do not let children play around the working area.
- Please confirm all parts are correct before starting the assembly process.
- Do not tighten all bolts and screws completely until the entire unit has been assembled and set up.
- Be careful if using power tools as they can over tighten screws and strip threads.

CARE & MAINTENANCE: The touch of a soft cloth is all the maintenance the finish will ever need. Please do not use harsh or abrasive cleaners for polishing, as they may cause damage to the finish. Periodic checks are recommended to make sure that all hardware is securely tightened.

STEP 1 - Figure 1

Begin assembly by attaching Adjustable Feet (1) to all the Leg Panels (A, B, C, D, E, & F) by screwing them into place.

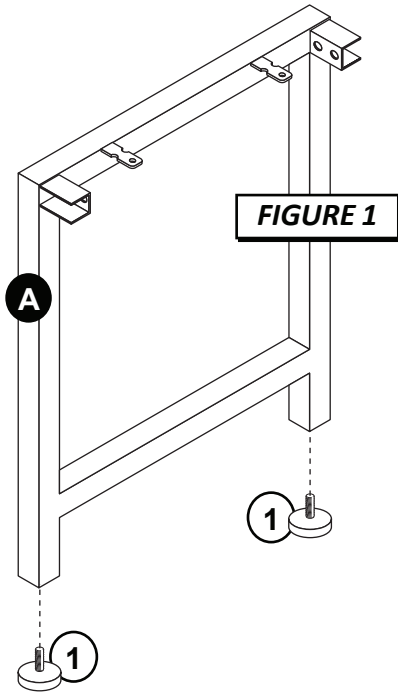

STEP 2 - Figure 2

Attach Large Top Stretchers (G) to Large Left Side Panel (A) and secure with 2 Allen Bolts (2), 2 Spring Washers (3) and 2 Flat Washers (4).

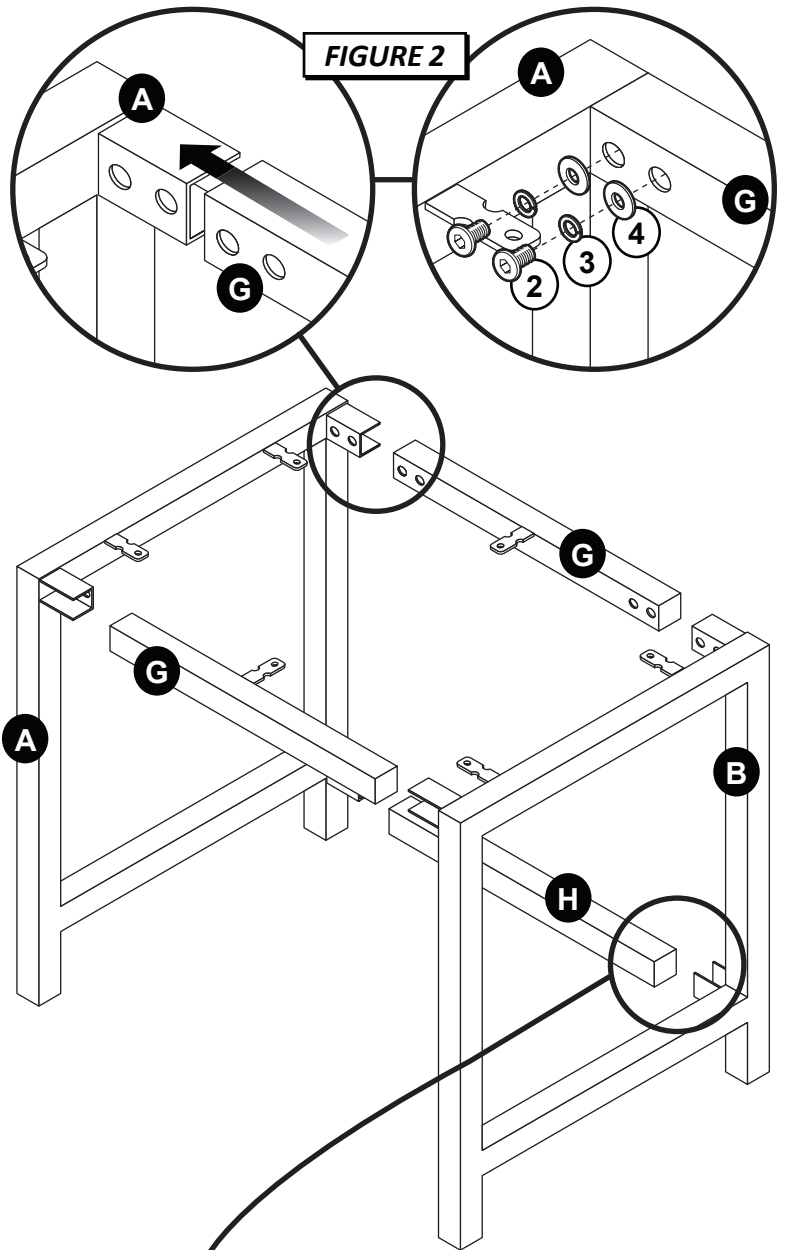

STEP 3 - Figure 3

Attach Large Bottom Stretcher (H) to Large Left Side Panel (A) and secure with 2 Allen Bolts (2), 2 Spring Washers (3) and 2 Flat Washers (4) from underneath.

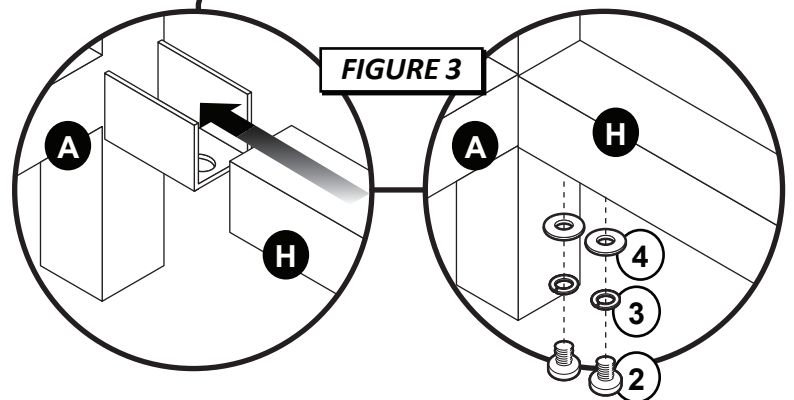

STEP 4

Repeat steps 2 and 3 to secure Large Right Side Panel (B) to Stretchers (G & H). Tighten all bolts using Allen Wrench (5) provided.

STEP 5

Repeat steps 2 through 4 to assemble the Medium and Small table frames.

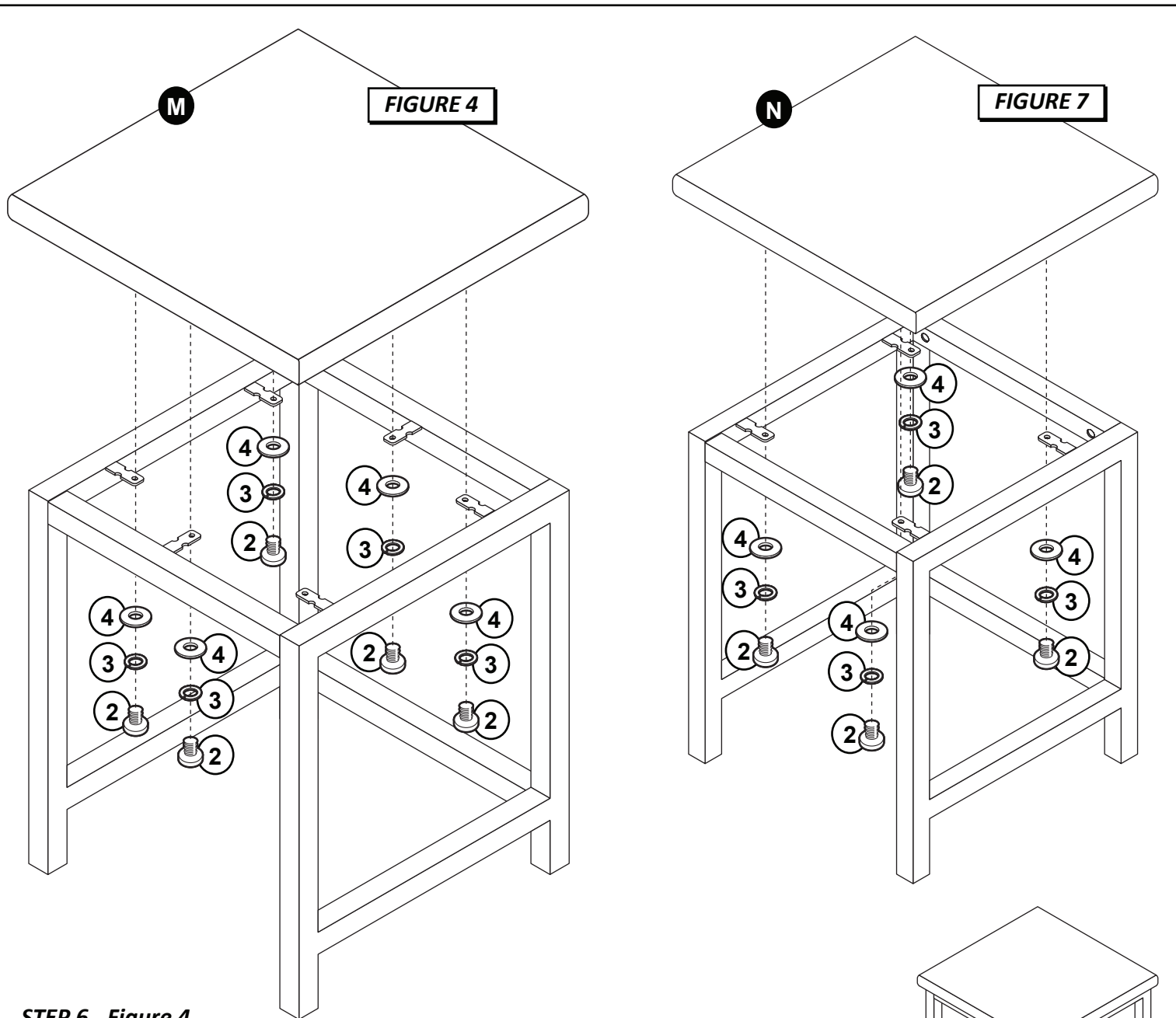

STEP 6 - Figure 4

Attach Large Top (M) to table assembly using 6 Allen Bolts (2), 6 Spring Washers (3) and 6 Flat Washers (4) from underneath. Tighten all bolts using Allen Wrench (5) provided.

STEP 7- Figure 7

Attach Medium Top (N) to table assembly using 4 Allen Bolts (2), 4 Spring Washers (3) and 4 Flat Washers (4) from underneath. Tighten all bolts using Allen Wrench (5) provided.

STEP 10 - Figure 8

For compact storage, slide Medium Table underneath Large Table and then slide Small Table underneath Medium Table. The assembly is now complete.

