

# ASSEMBLY INSTRUCTION

NO	PART LIST	QTY
1	HEADBOARD CUSHION	1PC
2	WING (L)	1PC
3	WING (R)	1PC
4	FOOTBOARD	1PC
5	FOOTBOARD LEG	2PCS
6	SIDE RAIL (L/R)	2PCS
7	SIDE RAIL (L/R)	2PCS
8	SIDE RAIL LEG	2PCS
9	SLAT	4PCS
10	SUPPORT LEG WITH ADJUSTABLE FEET	4PCS
ITEM	HARDWARE	QTY
A	JCBB SCREW M8 x 20MM	4PCS
B	JCBC SCREW M6 x 25MM	8PCS
C	JCBC SCREW M6 x 35MM	10PCS
D	JCBC SCREW M8 x 50MM	4PCS
E	JCBC SCREW M6 x 70MM	2PCS
F	WOOD DOWEL M8 x 30	2PCS
G	WOOD DOWEL M10 x 30	4PCS
H	SPRING WASHER M6 x 12MM	14PCS
I	FLAT WASHER M6 x 19MM	14PCS
J	SCREW M4 x 32MM	8PCS
K	L - KEY M5 x 65MM	1PC
L	L - KEY M4 x 65MM	1PC
M	SPRING WASHER M8 x 13MM	4PCS
N	FLAT WASHER M8 x 22MM	4PCS

STEP 1

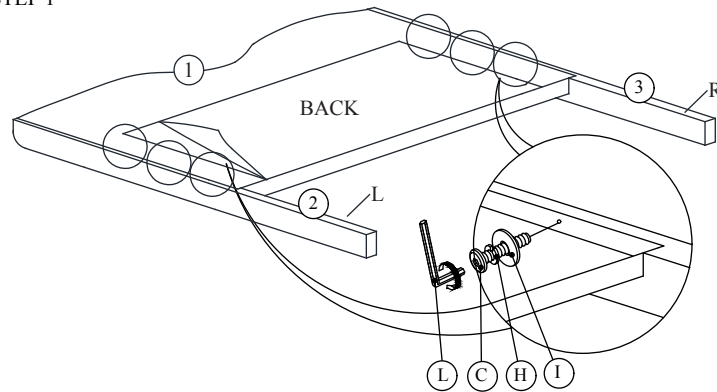

STEP 2

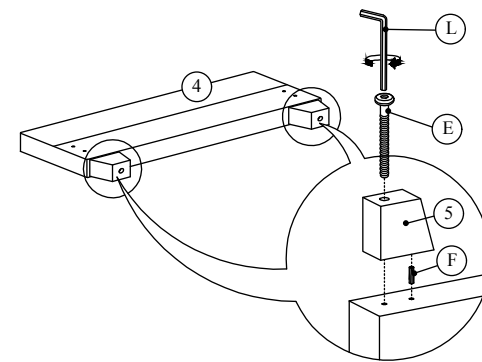

STEP 3

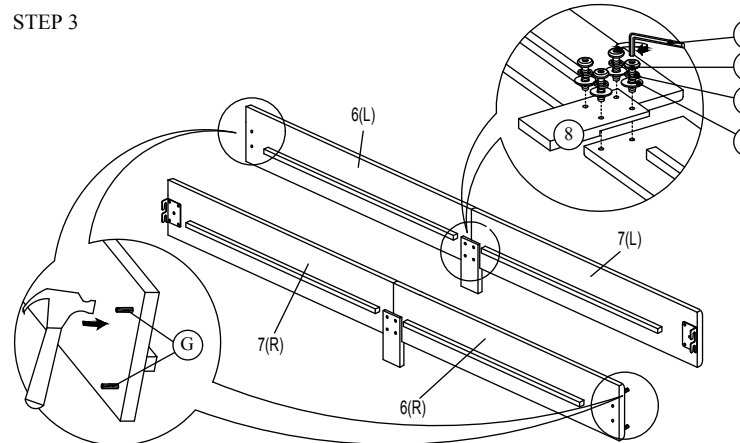

STEP 4

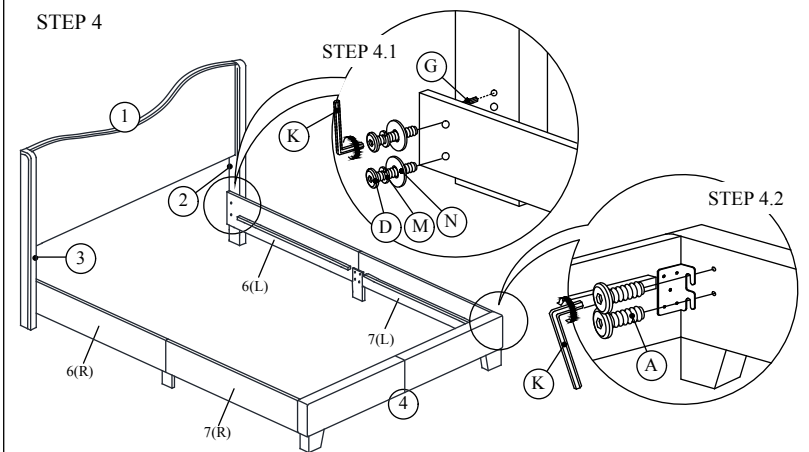

STEP 5

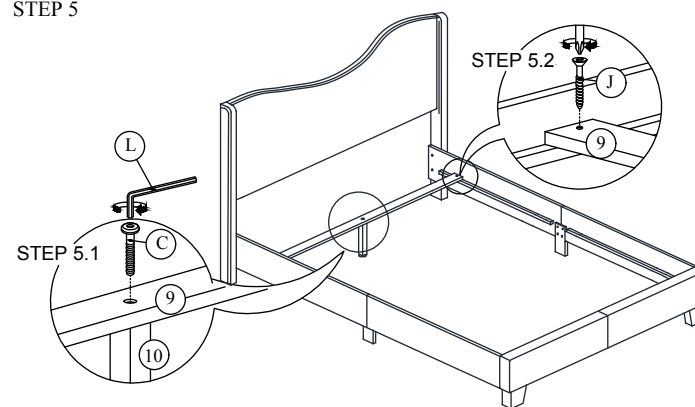

STEP 6

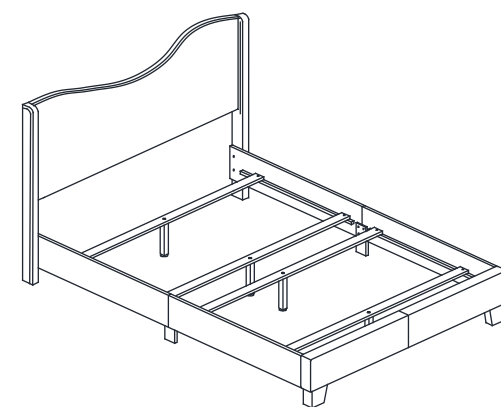

ASSEMBLY COMPLETE

Please do not tighten the hardware until the entire assembly is completed.