

INSTRUCTION

80 QT PATIO ROLLING ICE CHEST

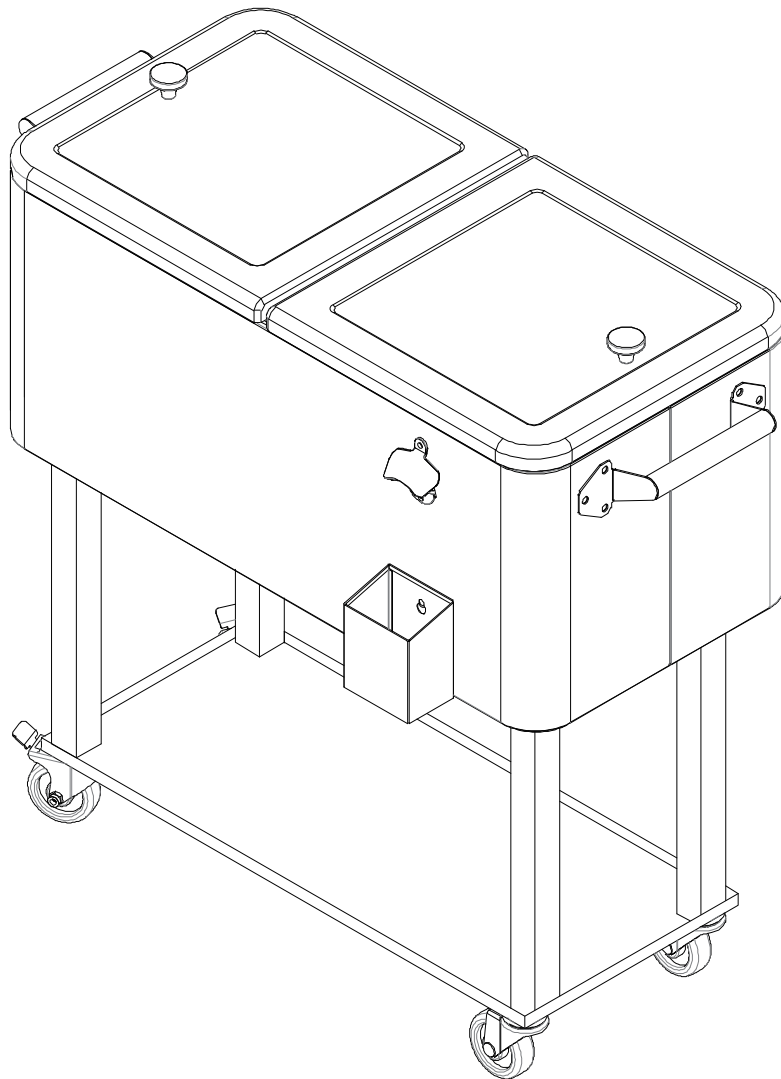

**After-sales mailbox:
Patiofurniture Serviceteam@outlook.com**

NOTICE

EN

Please keep these instructions for future reference.

Dear Customer

● Thank you for your purchase. When you receive the product, please make sure that all the parts are intact. If any parts are missing, please contact us promptly to request replacement parts.

● Then follow the entire installation instructions to install.

● Each part is crucial, so please be careful not to lose any. It is recommended to store parts with different lettered identifiers in separate boxes or bags to avoid confusion during installation.

A . The outer box is damaged

B . The product is damaged / bent / cracked while you open the box

C . The parts / accessories / assembly tools are missing

D . The instructions are not clear and can not be referred

E . The product has functional problems

F . Other aspects that you are not satisfied with









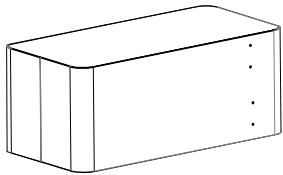
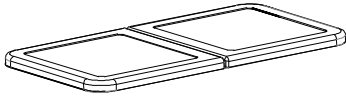
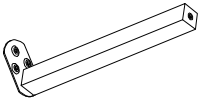
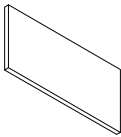

Please feel free to contact us for help, and provide the following information:

Platform/Shop name/Order id/Buyer's name/Receiver's address/Problem description/Problem pictures

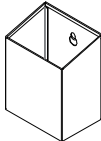
(**Patiofurnituresteam@outlook.com**) will reply within 24 hours and will do our best to resolve the problem for you.

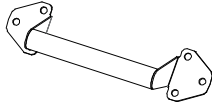

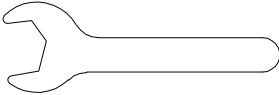
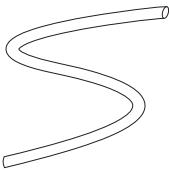
PART LIST

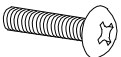
A		1pcs	B		1pcs
C		4pcs	D		1pcs
E		2pcs	F		2pcs
G		1pcs	H		1pcs
I		2pcs	J		2pcs
1		1pcs	2		1pcs
3		1pcs	aa	 M6x16mm	28pcs
bb	 M5x35mm	2pcs			

STEP

01

aa

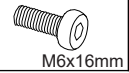

12pcs

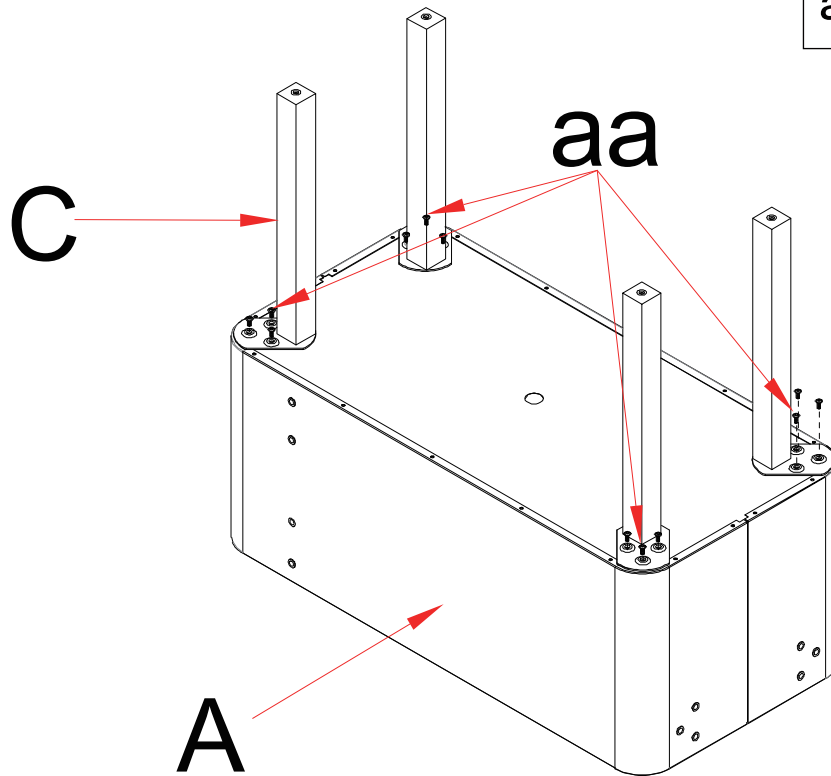

02

bb

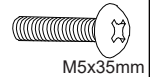

2pcs

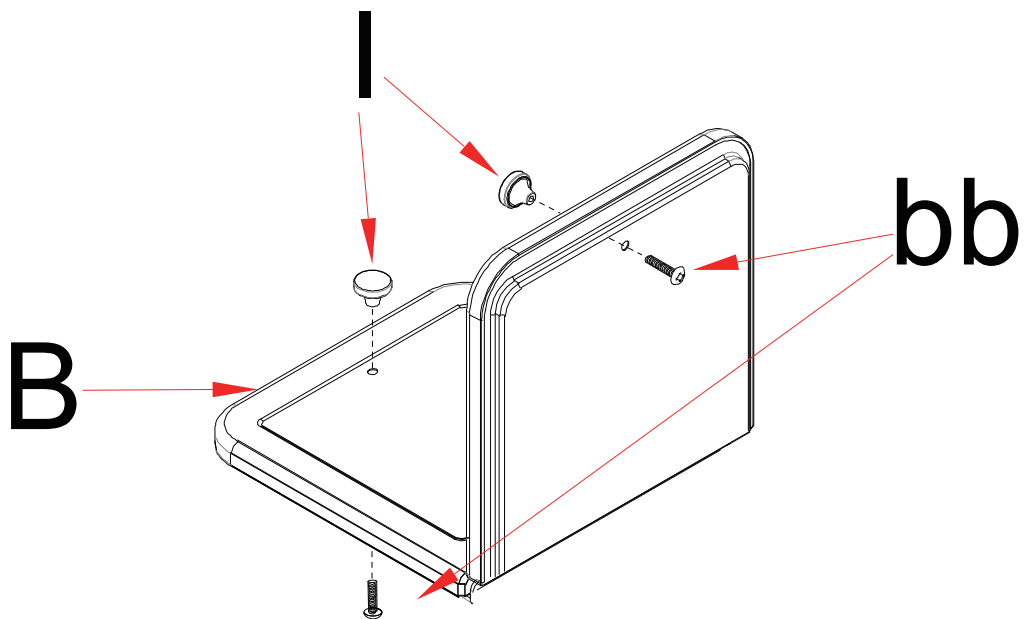

03

Both Part E and Part F shall be installed in pairs in the same direction.

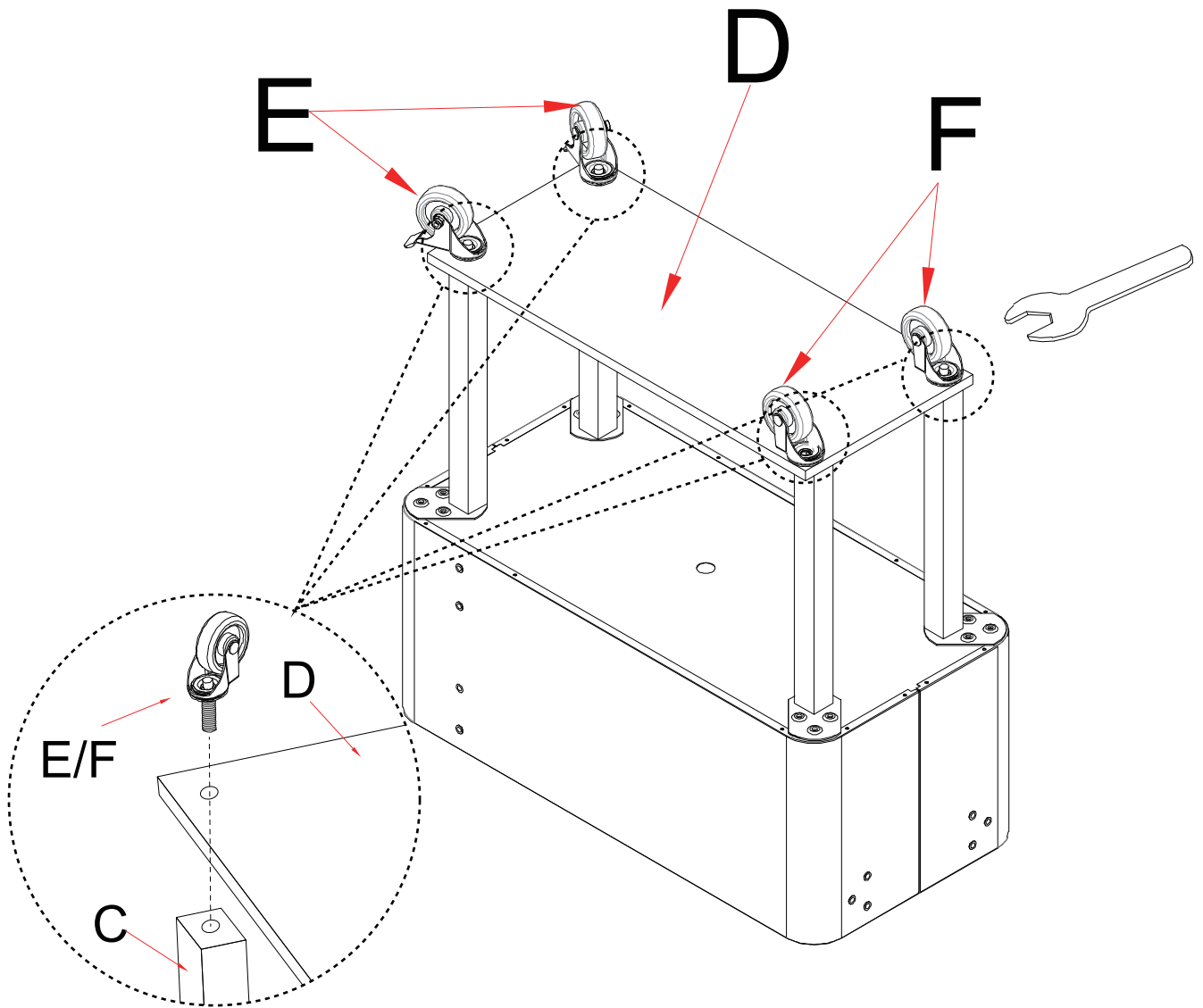

After securing, use a wrench to hold the screw behind part E and part F, and tighten them.

04

aa

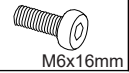

16pcs

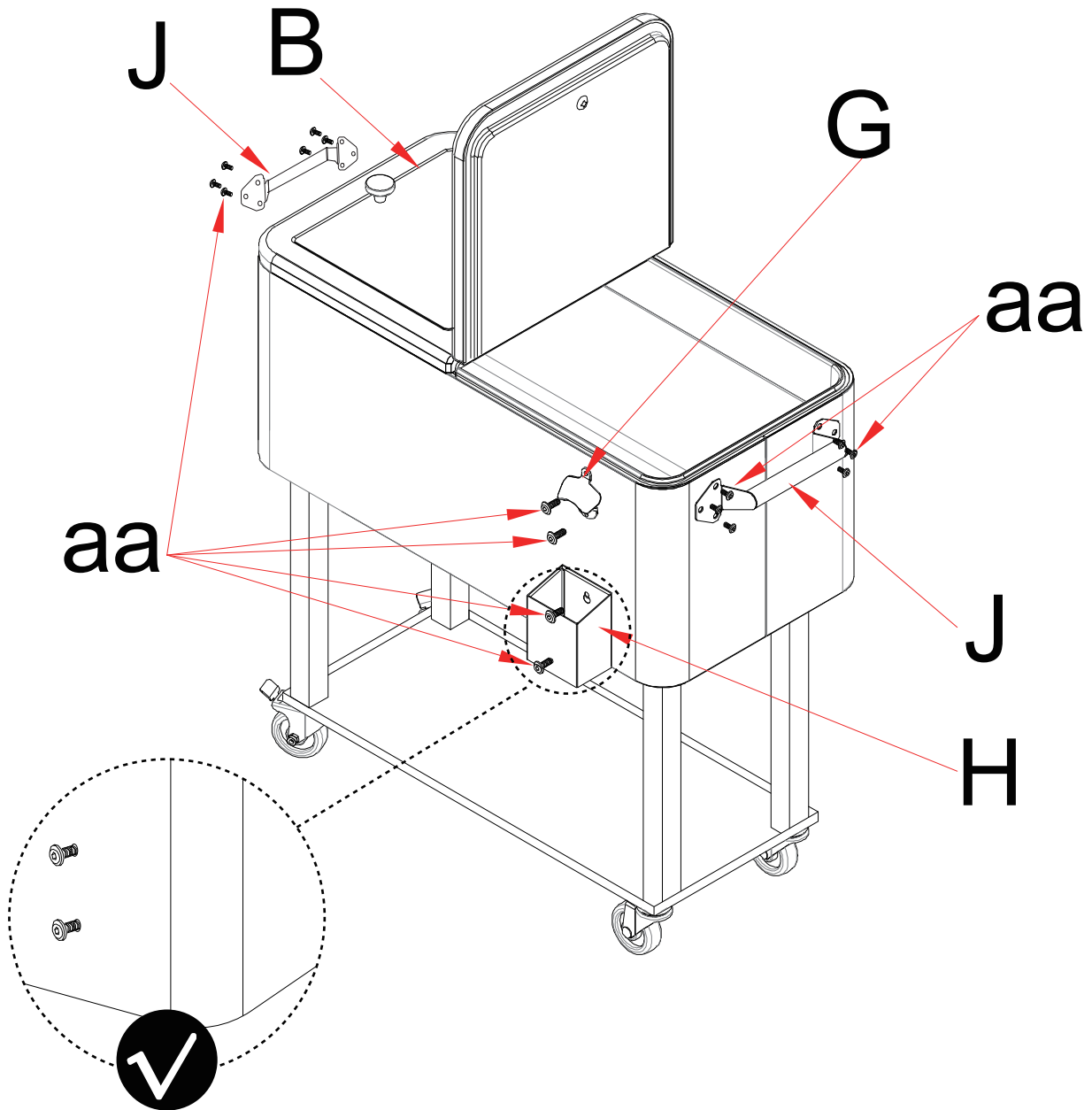

When installing the screw at part H, do not tighten it fully. Leave approximately 3mm of the screw exposed to hold part H.

05

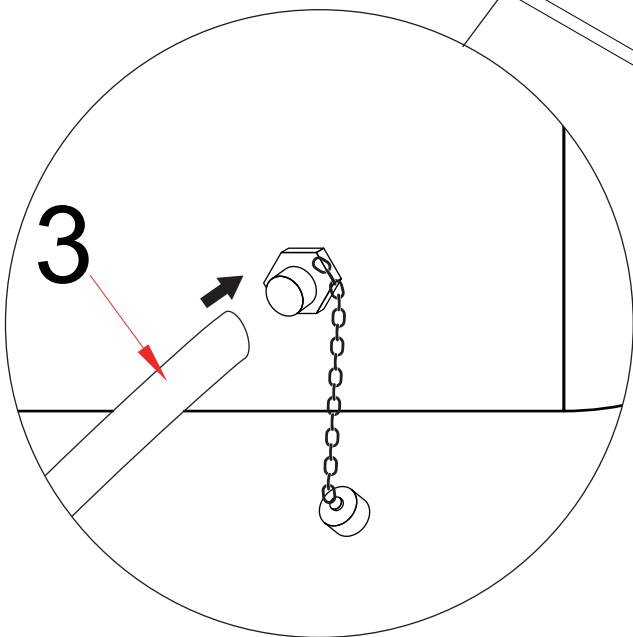
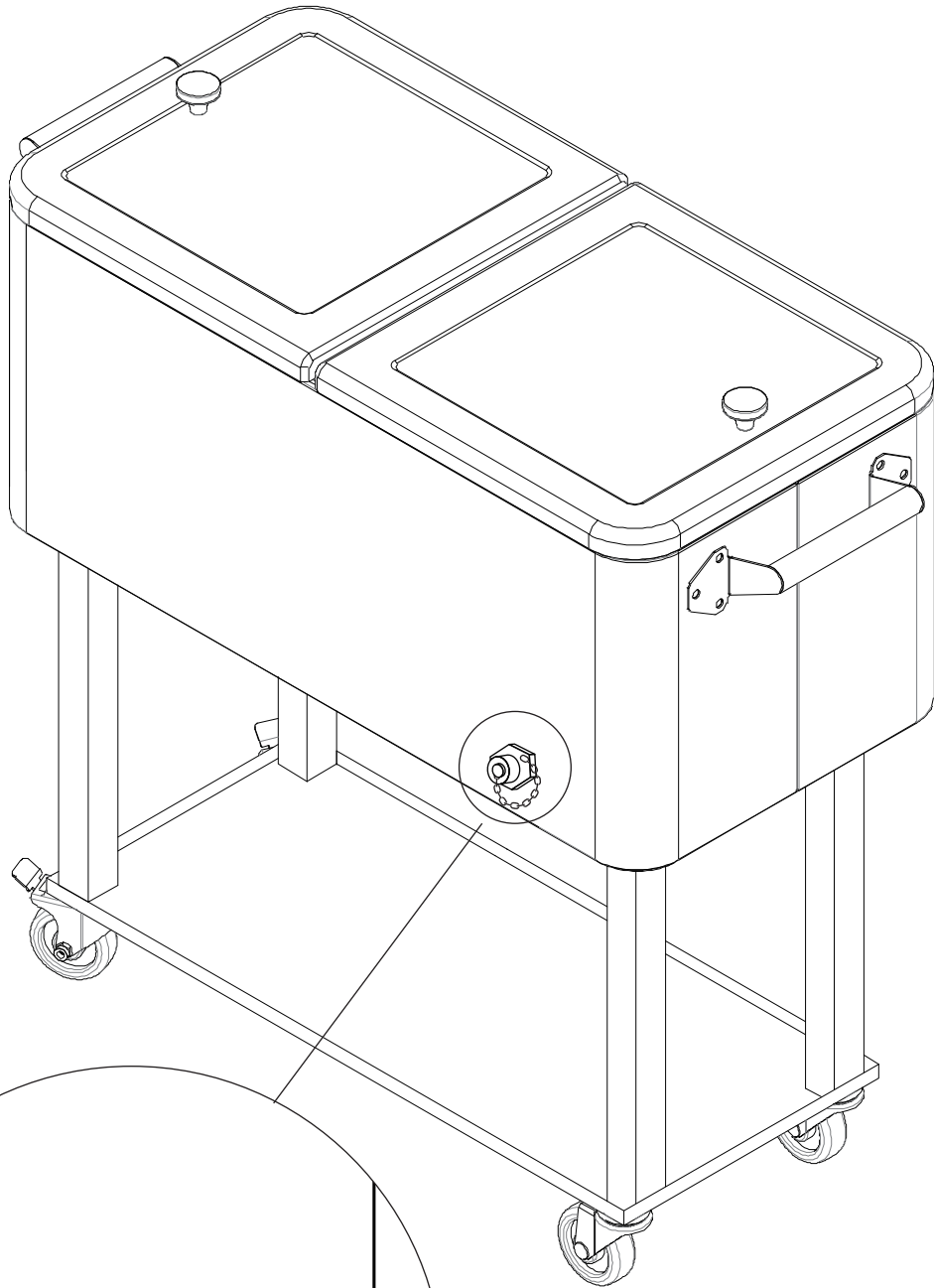

To drain the water from the ice cart, you can unscrew the cover located at the bottom of the tank and connect a water pipe (Part 3) to channel the water onto the ground.

EN

AFTER-SALE SERVICE

If you have any suggestions for our products or notice any quality issues, please contact us first. Our after-sales team will respond within 24 hours and will do everything possible to provide you with a satisfactory solution.

Guaranteed Customer Service

Your shopping experience is very important to us!

Feel unsatisfied? **Contact us!**

Have any questions? **Contact us!**

Wanna Share how wonderful our smart products make your home?

Share your pictures with us.

Any suggestions? **Contact us!**

We will check and give feedback.



Patiofurniture Serviceteam@outlook.com

