

**9" Desk Fan White**



**DF9010**

Batch code:

**Please read these instructions carefully before use and retain for future reference**

**Before switching on your appliance,  
always check for any damage which may have been caused in transit**

## CONTENTS

Safety Instructions.....	2-3
Appliance Overview.....	3
Mounting Instructions.....	4
Operating Instructions.....	4
Cleaning & Maintenance.....	4
Fuse Replacement.....	4
Trouble Shooting Guide.....	5
Disposal information.....	5
Igenix Warranty Terms & Conditions.....	6-7

## SAFETY INSTRUCTIONS

Please read this user manual carefully to ensure proper use, maintenance and installation.

1. This product is intended for domestic and light office use **ONLY** and not for commercial, industrial or outdoor use.
2. Do not operate the unit with a damaged cord or plug, after it malfunctions or has been dropped or damaged in any way.
3. All electrical repairs must be carried out by a qualified electrician. Inadequate repairs may result in a major source of danger for the user and invalidate the warranty.
4. Make sure the voltage in your home corresponds to the one shown on the rating label of the appliance.
5. This unit should always be kept in an upright position especially during operation to avoid any damage. Locate the unit on a flat stable surface.
6. Position the power cord where people will not step on or trip over it.
7. Ensure that the air inlets and outlets are not blocked or covered.
8. Do not place the unit too close to curtains or other objects - min 30cm.
9. Never insert fingers, pencils or other objects into the unit. Warn your children against these dangers.
10. This appliance should only be used by adults.

11. Keep the appliance and its cord out of reach of children.
12. Children shall not play with the appliance.
13. Cleaning and user maintenance shall not be made by children.
14. This appliance is not intended for use by persons (including children) with reduced physical, sensory or mental capabilities, or lack of experience and knowledge.
15. Unplug the unit from the socket when not in use. Do not pull on the cord.
16. Do not use the unit near a bath, shower, swimming pool or anywhere it could be splashed with water.
17. Do not expose the unit to direct sunlight.
18. Do not use the unit near flammable or explosive gases.
19. Before cleaning or moving the unit, switch it off and unplug the power cord.
20. Do not leave the unit unattended during operation.  
Always unplug the power cord when not in use.

## APPLIANCE OVERVIEW

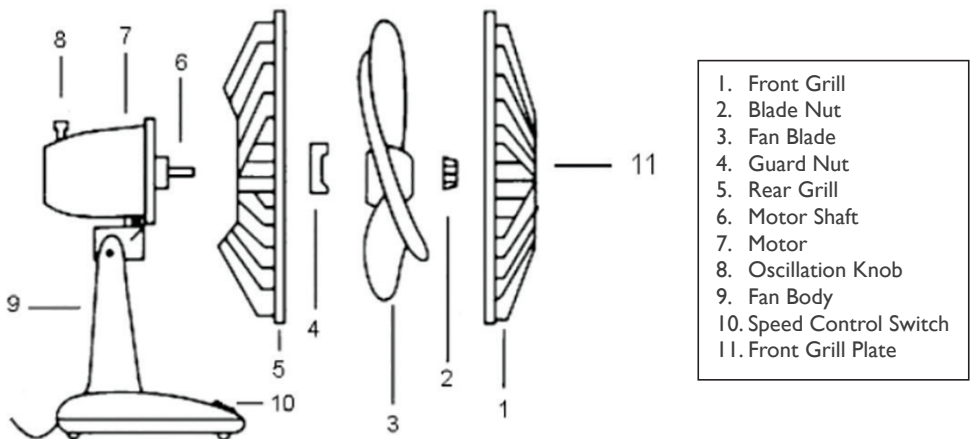

## MOUNTING INSTRUCTIONS

- Take the unit out of the box, removing any packaging.
- Remove the guard nut from the guard thread.
- Position the rear grill onto the motor and then fasten the guard nut back onto the motor shaft turning clockwise until secure.
- Push the fan blade along the motor shaft, and fix it with the blade nut.
- Assemble the front grill plate onto the front grill using the 3 screws and 3 washers provided.
- Align the front grill to the rear grill and clip into place.
- At the base of the grill, secure the front and rear grill together by using the screw and nut provided.

## OPERATING INSTRUCTIONS

- Place the fan on a flat and even surface
- Plug the power cord into a power socket
- Select the required speed by pressing the buttons  
0 = Off  
1 = Low Speed  
2 = High Speed
- Push the oscillation knob down to start oscillation
- Pull the oscillation knob up to stop oscillation

## CLEANING AND MAINTENANCE

- Turn off the fan and remove the plug from the power socket before cleaning
- Use a dry soft cloth to remove any dust from the fan
- If the fan is particularly dirty use a soft damp cloth and wipe dry
- Do not use any chemicals or detergents as they will damage the fan
- It is recommended to cover the fan with a plastic bag before storage to prevent dust collecting on fan blade
- Store the fan in a ventilated and dry area
- Do not allow water to get inside the body of the fan

## MAINS PLUG FUSE REPLACEMENT

### Fuse Replacement (Class II)

Remove the fuse cover with a small flat head screw driver. Take out the fuse and replace with a new fuse of the same Amp. Replace the fuse cover and push back into place.

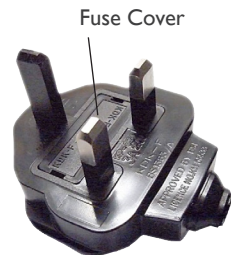

# TROUBLE SHOOTING GUIDE

Problem	Possible Cause	Solution
The fan does not work	<ol style="list-style-type: none"><li>1. Not properly plugged into the mains wall socket</li><li>2. Not switched on</li><li>3. No electricity in the mains wall socket</li></ol>	<ol style="list-style-type: none"><li>1. Plug in firmly</li><li>2. Switch on</li><li>3. Check fuse or breaker</li></ol>
The fan is too noisy	<ol style="list-style-type: none"><li>1. Sitting unevenly</li><li>2. Not secured together correctly</li></ol>	<ol style="list-style-type: none"><li>1. Ensure fan is sitting on flat surface</li><li>2. Make sure all components are secured correctly</li></ol>
The air speed is too fast	<ol style="list-style-type: none"><li>1. Fan setting is too high</li></ol>	<ol style="list-style-type: none"><li>1. Adjust setting accordingly</li></ol>

## DISPOSAL INFORMATION

The European Directive 2012/19/EU on Waste Electrical and Electronic Equipment (WEEE), requires that old household electrical appliances must not be disposed of in normal unsorted municipal waste.

Old appliances must be collected separately in order to optimise the recovery and recycling of the materials they contain and reduce the impact on human health and the environment.

The crossed out “wheeled bin” symbol on the product reminds you of your obligation, that when you dispose of the appliance it must be separately collected. Consumers should contact their local authority or retailer for information concerning the correct disposal of their old appliance.





## Igenix Warranty Terms & Conditions

This product is guaranteed for a period of 12 months as standard from the date of purchase against mechanical and electrical defects. You can extend your warranty for a further 12 months by registering your product.

Upon registration we will cover your product for a period of 24 months from the original purchase date against any mechanical or electrical defects.

To qualify for the guarantee, the product must be used for domestic household use only and in accordance with the instructions in the user manual. Any misuse of the product will result in the warranty being void.

The guarantee does not cover accidental damage, misuse, neglect, tampering or incorrect adjustment or installation.

The guarantee will be rendered invalid if the product is resold, has had its serial number removed (or has an invalid serial number), or if an unauthorised person has carried out any repairs or alterations.

The warranty does not cover accessories or consumable parts that require replacement under normal use. This includes shelving, dials, filters, belts and trays etc.

In the unlikely event of a breakdown please refer to the Troubleshooting guide in your user manual and check all plugs, fuses and the electricity supply.

If you still require assistance please contact our Customer Service department on **01473 271 272** or write to us at the following address:

**Customer Service Department  
38 Bluestem Road, Ransomes Europark  
Ipswich, IP3 9RR**

Please quote the Product Code which begins 'IG' or 'DF' and the Batch Code beginning '5' and give details of the exact fault. We will then decide whether to repair or replace the item.

Before we arrange the repair or replacement you will be required to return a copy of your proof of purchase. Please retain your original.

If an item is replaced within the agreed guarantee period, the guarantee for the replacement item will be calculated from the purchase date of the original.

In the event that the product is inspected and no fault is found or the product is not within the guarantee period you will be charged for the repair and any carriage costs.

# igenix

## Thank you for choosing Igenix

As a valued customer we would like to offer you a FREE 2 year warranty to cover your product against any electrical or mechanical defects.

This means that in the unlikely event you develop a fault or problem with your product we will happily repair or replace the item free of charge.

To qualify for the 2 year warranty you must register your product within 30 days of purchase. The full Terms & Conditions of our warranty policy are shown on the opposite page. They are also available on our website. **www.igenix.co.uk**

To register your product, please complete all sections of the form below and return to us at the following address: Igenix, 38 Bluestem Road, Ransomes Europark, Ipswich, IP3 9RR.

Alternatively you can visit the Igenix website and complete the form online.

### Customer Details:

Title: \_\_\_\_\_ First Name \_\_\_\_\_ Surname: \_\_\_\_\_

Address: \_\_\_\_\_

Post Code: \_\_\_\_\_

Email: \_\_\_\_\_

Telephone: \_\_\_\_\_

### Product Information:

Product Code (Beginning IG or DF): \_\_\_\_\_ Product Description: \_\_\_\_\_

Batch Number (Beginning 5): \_\_\_\_\_ Serial Number (if applicable): \_\_\_\_\_

Date of Purchase: \_\_\_\_\_

Retailer Name: \_\_\_\_\_

Retailer Location: \_\_\_\_\_

Please tick here to confirm you have read and accept our Terms & Conditions

Please tick here if you DO NOT wish to receive marketing information from us

Customer Signature: \_\_\_\_\_ Date: \_\_\_\_\_

# igenix

38 Bluestem Road, Ransomes Europark, Ipswich, IP3 9RR

Tel. 01473 271 272

Disclaimer: Igenix operate a policy of continual improvement and development.  
We therefore reserve the right to change/alter the specification and appearance of our appliances without prior notice.  
All diagrams and images shown in this manual are for illustration purposes only.