

ASSEMBLY INSTRUCTIONS

Disclaimer:

Thank you for your purchase. Please read carefully and keep these instructions, as you may need them later. We suggest installation by a **licensed electrician**.

Beware of potential electrical shock! Before installing the fixture or removing any other light already present, please turn off the main power at the circuit breaker.

If your product contains glass items, please handle with care, as glass is fragile and can lead to injuries if handled incorrectly.

Please keep in mind that the warnings and instructions present in this document are not meant to cover and prevent all possibilities and situations that could lead to injury or damage. It is the responsibility of the end-user to exercise caution and common sense when handling and installing the product.

All electrical connections must be made by qualified personnel in accordance with the National Electrical Code.

Please refer to the table below for electrical connections:

Fixture wire markings:

"L" Live wire (Black or Brown)

"N" Neutral wire (White or Blue)

"⊕" Ground wire (Bare copper or Green)

AC power equivalent:

"L" Live wire (Black)





"N" Neutral wire (White)

"⊕" Ground wire (Bare copper or Green)

Note: Select the type of installation you require before assembly and installation:

This luminaire can be installed as a Pendant or Close to Ceiling.

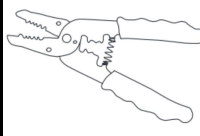
Refer to the corresponding instructions and diagram for the different installation methods.

Tools Required: (not included)				
				
Step Ladder	Phillips Head, Flat Blade Screwdrivers	Electrical tape	Wire Cutter/Stripper	Plier

Pendant lamp Installation instructions:

Step 6. Use the screw nut(D) secure canopy(C) to the mounting bracket(A).

Step 3. Install the chain between ring(F) and canopy(C) by activity buckle(E), the chain is adjustable .And pass the main wire through the chain.

Step 2. Insert into the bottom of the lamp frame (I) with glass rod(J), glass rod(P) into the frame(M), and use screws (Q*4) to lock the ring (R&K)

Step 4. Use the two screws(B) secure mounting bracket(A) to the junction box.

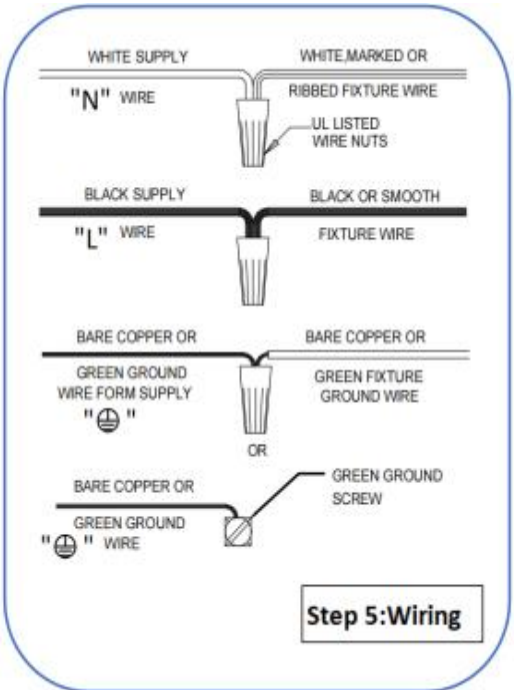

Step 1. As shown in the diagram, use a screwdriver to unscrew the screws (Q) and take off the ring (R&K).

G(not included)

Step 7. Install light 10pcs E12 LED bulbs (G) (not included).

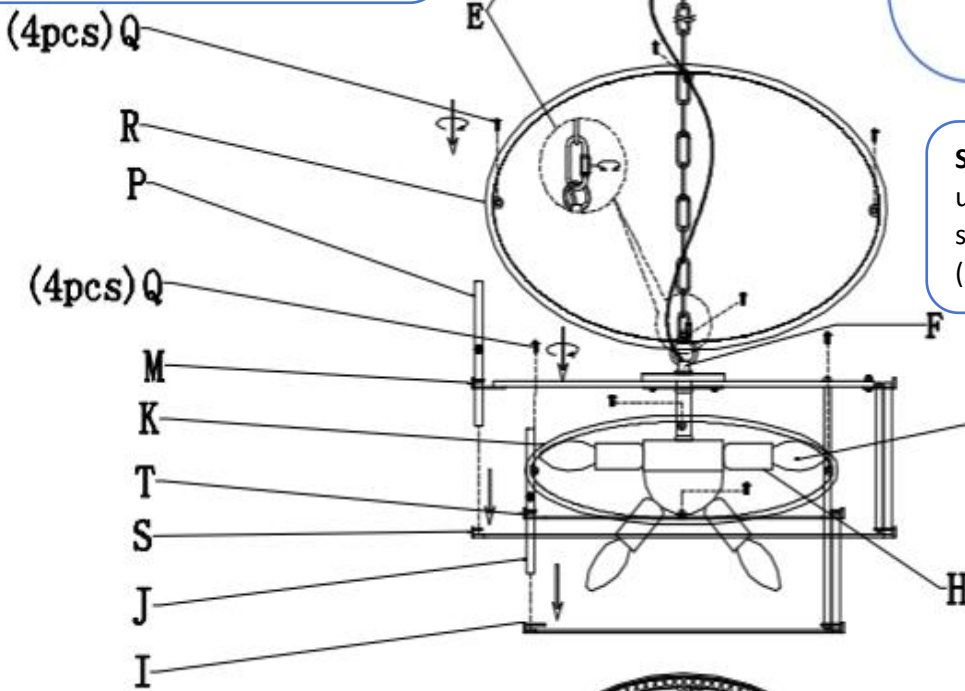

Parts Included:	
I-	P-

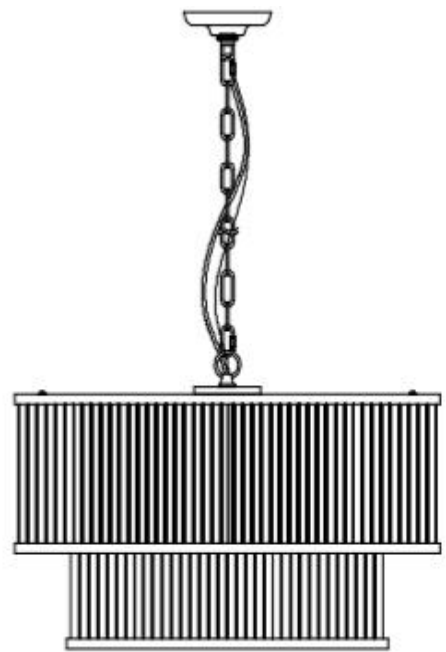
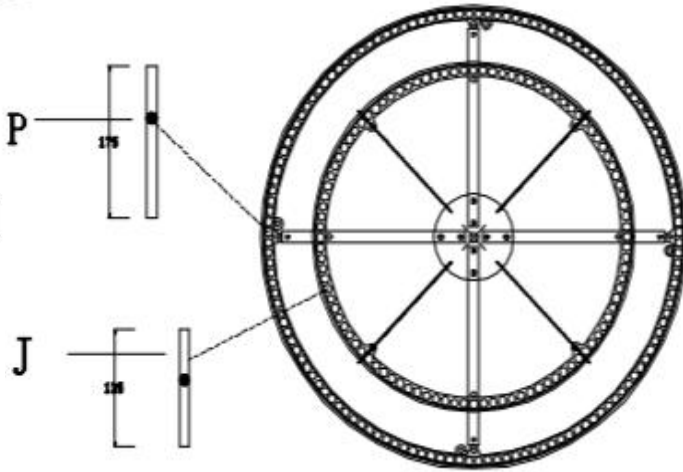

Close to Ceiling Installation instructions:

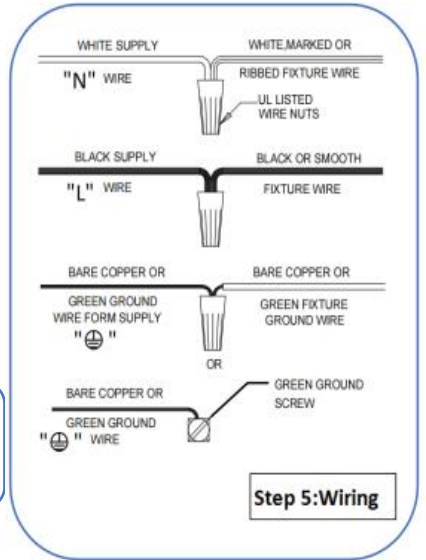
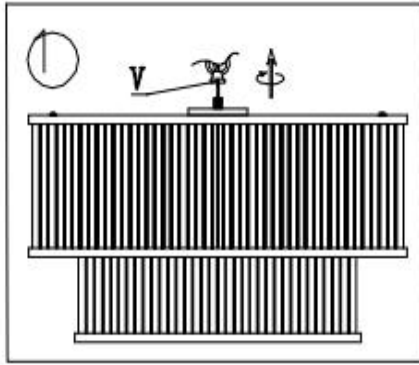
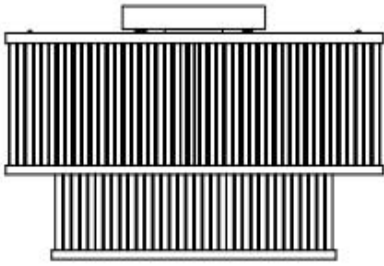

Step 7. Use the screw nut (E) secure canopy (D) to the mounting bracket (A).

Step 1. Take off the ring (V) by screwdriver as shown in the diagram above .

Step 6. Use the two screws (U) secure mounting bracket (A) to the junction box.

Step 3. use a screwdriver to unscrew the screws (Q) and take off the ring (R&K).

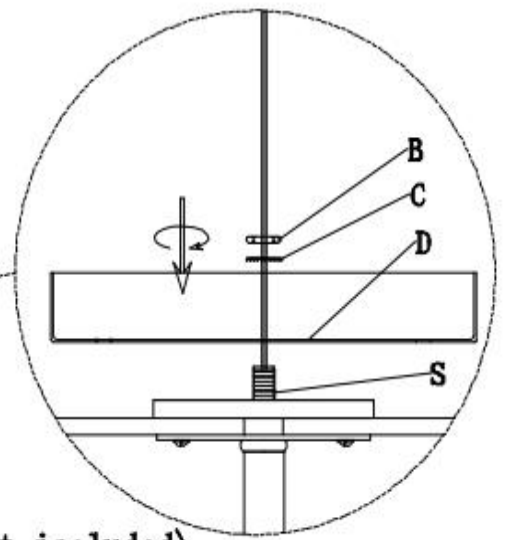

Step 2. Put the ceiling cover (D) and washer (C) onto the threaded pipe (S), and secure it with the nut (B).

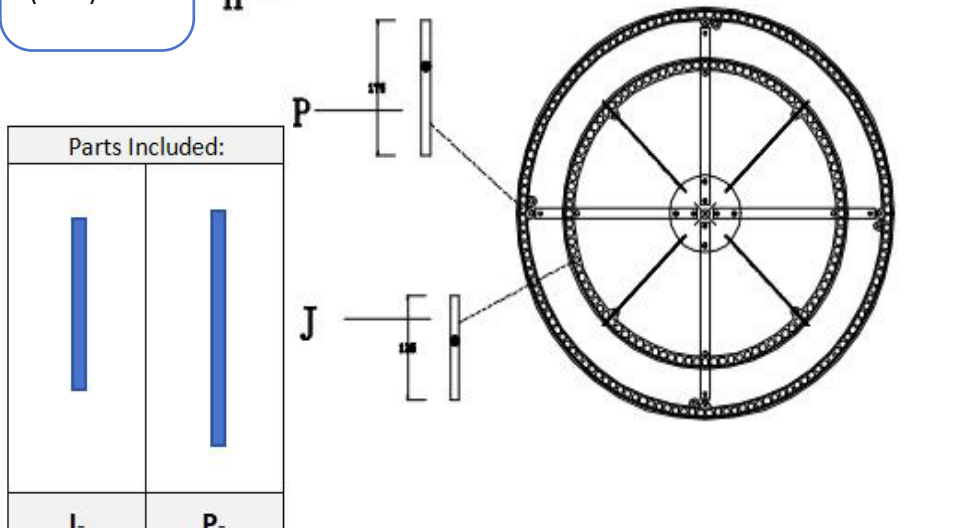

Step 4. Insert into the bottom of the lamp frame (H) with glass rod (J), glass rod (P) into the frame (M), and use screws (Q*4) to lock the ring (R&K) tightly.

Step 8. Install light 4pcs E12 LED bulbs (F) (not included).

Parts Included:	
I-	P-

Warranty

1-YEAR LIMITED WARRANTY

The manufacturer warrants this product to be free from defects in materials and workmanship for one (1) year from the date of purchase. This warranty is valid only for the original consumer purchaser and covers the product under normal use and conditions. If the product is found to be defective, the manufacturer's sole obligation and your exclusive remedy is to repair or replace the product at the manufacturer's discretion, provided it has not been damaged by misuse, abuse, accident, alteration, modification, negligence, or mishandling.

This warranty does not cover labor or any costs associated with the removal or installation of defective, repaired, or replaced products. The warranty excludes damages resulting from misuse, mishandling, misapplication, negligence (including improper maintenance), accidents, incorrect installation, modifications (including unauthorized parts or accessories), or adjustments and repairs.

If you experience damage or missing accessories during the warranty period, please contact our customer service team with your original order number, the quantity of required accessories, and your current shipping address. We will arrange for the free replacement parts as needed.