

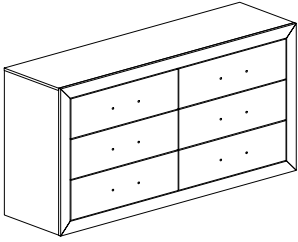

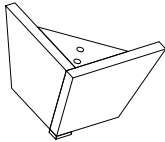

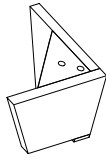

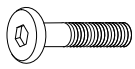

ASSEMBLY INSTRUCTION

PART LIST

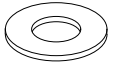
A	DRESSER		1 PC
B	LEG (i)		2 PCS
C	LEG (ii)		2 PCS
D	CENTER SUPPORT LEG		1 PC

HARDWARE LIST

ITEM	DESCRIPTION	DRAWING	QTY
1	JCBB SCREW M6 x 40MM		4 PCS
2	SPRING WASHER M6 x 13MM		4 PCS
3	FLAT WASHER M6 x 19MM		4 PCS
4	WOOD DOWEL Ø8 x 30MM		4 PCS
5	ALLEN KEY M4		1 PC
6	TIPPITNG RESTRAINT		1 SET

ASSEMBLY TOOLS REQUIRED

1. Screwdriver (not provide)

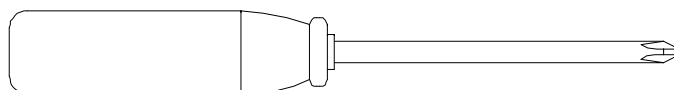

ASSEMBLY INSTRUCTION

STEP 1

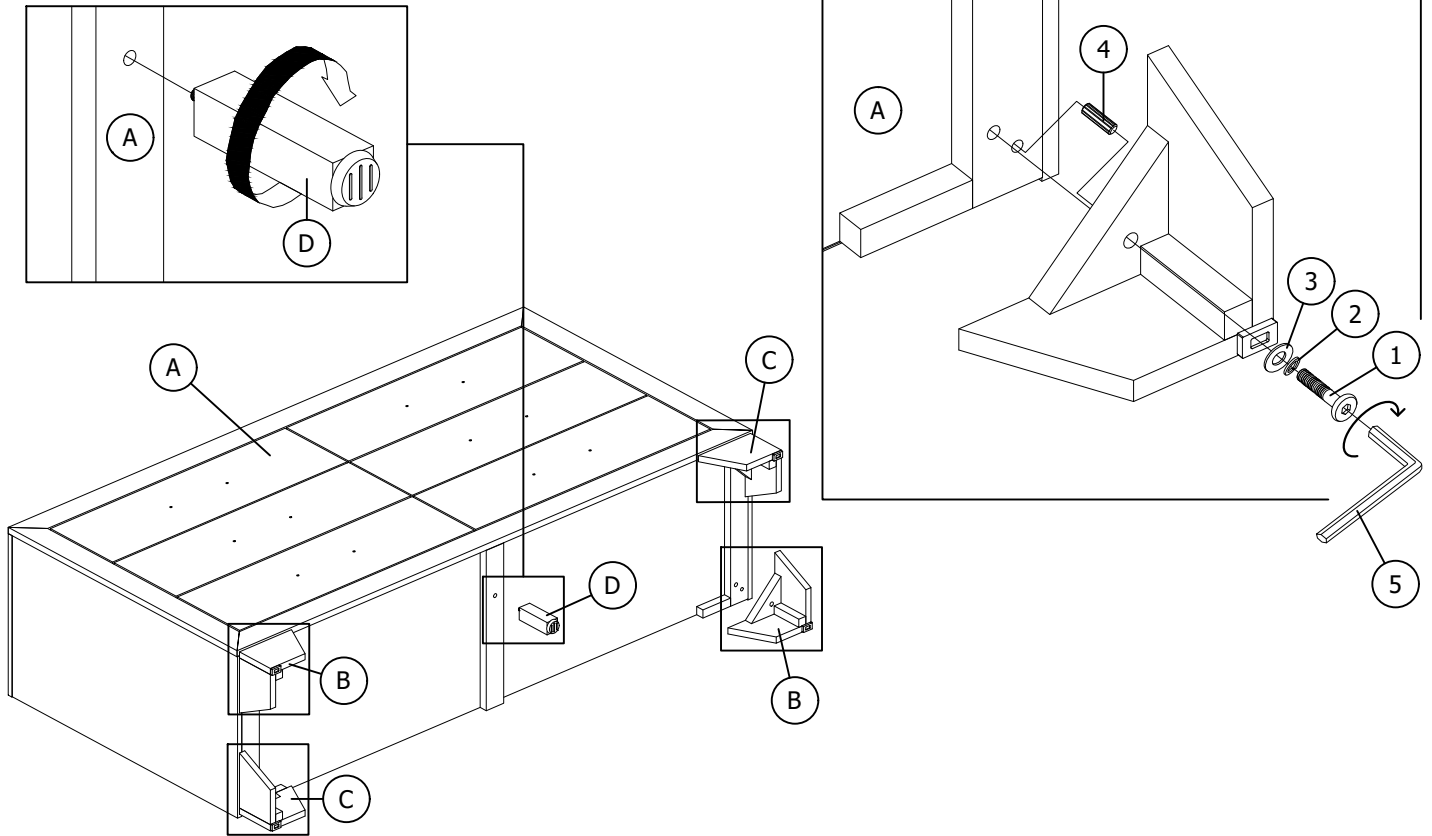

STEP 2

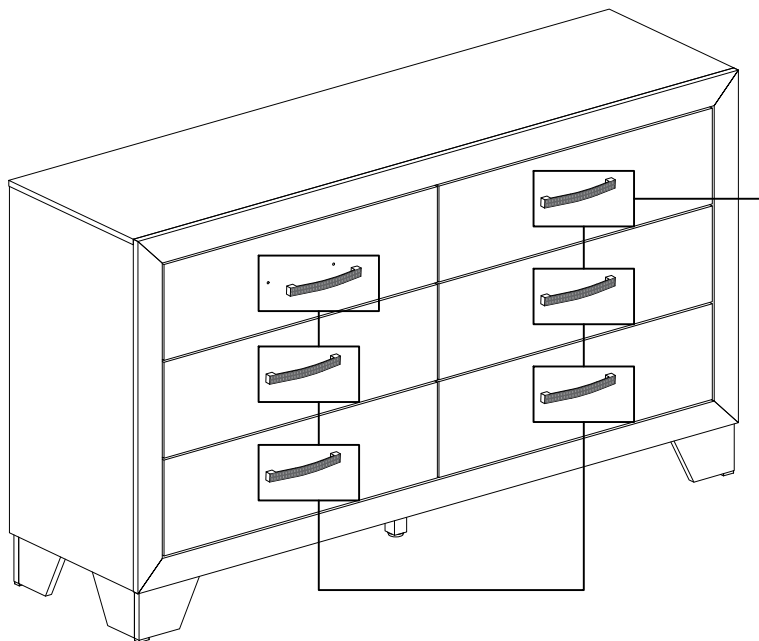

STEP 2.1

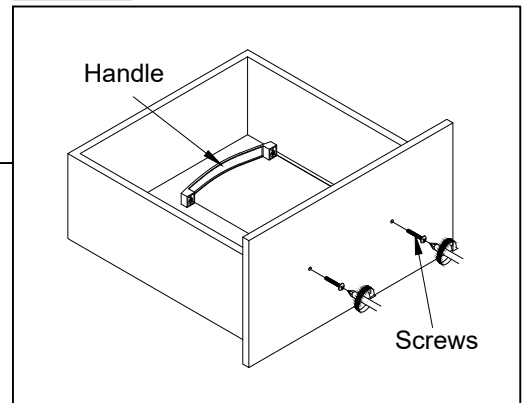

STEP 2.2

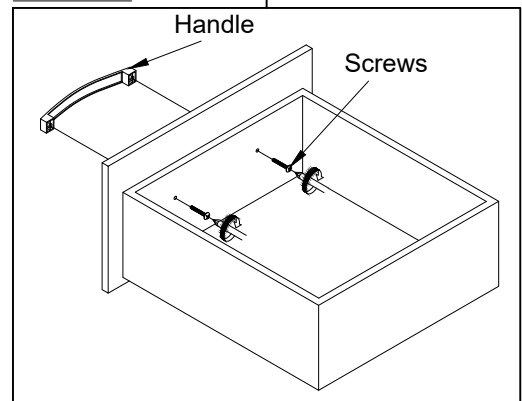

ASSEMBLY INSTRUCTION

STEP 3

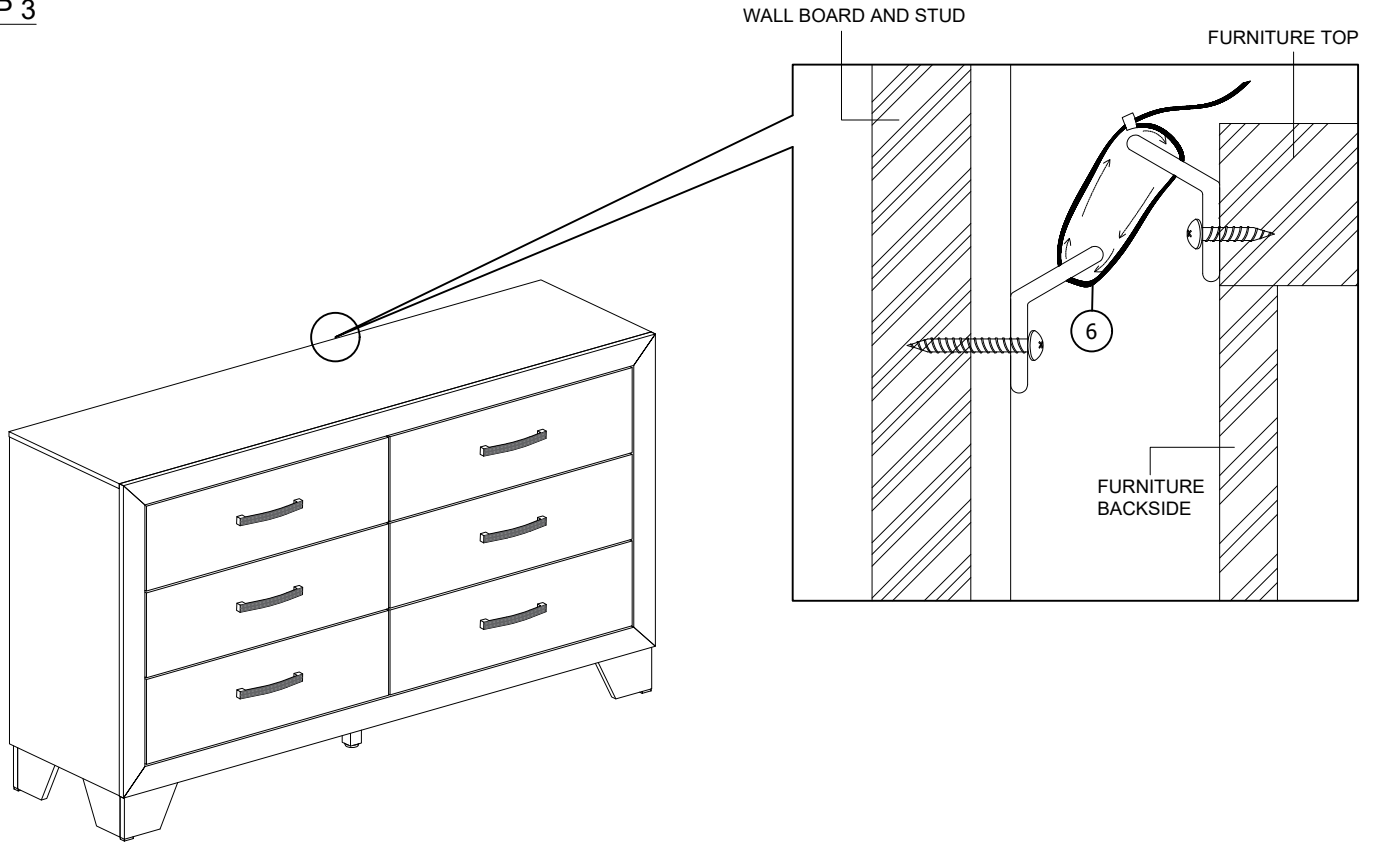

ASSEMBLY COMPLETED