

Pure & Easy



# **ASSEMBLY INSTRUCTIONS**





# WARNING

## Battery Safety Warning

- This product may or may not contain a button cell or coin battery depending on the model configuration.

## INGESTION HAZARD

- Death or serious injury can occur if swallowed. A swallowed button or coin cell battery can cause **Internal Chemical Burns** in as little as **2 hours**.
- **KEEP** new and used batteries **OUT OF REACH of CHILDREN**.
- Seek immediate medical attention if a battery is suspected to have been swallowed or inserted inside any part of the body.

## Battery Use and Handling

- Use only compatible battery types (e.g., LR44, CR2032) with the correct nominal voltage.
- Install batteries according to correct polarity (+/-).
- Do not mix old and new batteries, different brands, or different types (e.g., alkaline, carbon-zinc, or rechargeable).
- Remove batteries from devices not used for extended periods.
- Recycle or dispose of used batteries properly, following local regulations. Do NOT throw into household trash or incinerate.
- Do NOT recharge non-rechargeable batteries.
- Do NOT force discharge, disassemble, heat above the manufacturer's recommended temperature, or incinerate. This may cause leakage, explosion, or chemical burns.

## Battery Compartment Safety

- Always ensure the battery compartment is completely secured.
- If the compartment does not close properly, stop using the product. Remove the batteries and keep them away from children.



# NOTICE

IMPORTANT, RETAIN FOR FUTURE REFERENCE: READ CAREFULLY  
WICHTIG, FÜR SPÄTERE NACHSCHLAGE AUFBEWAHREN: SORGFÄLTIG LESEN  
IMPORTANTE, GUARDAR PARA REFERENCIA POSTERIOR: LEER ATENTAMENTE  
IMPORTANTE, CONSERVARE PER RIFERIMENTI FUTURI: LEGGERE ATTENTAMENTE  
IMPORTANT, À CONSERVER POUR RÉFÉRENCE FUTURE : LIRE ATTENTIVEMENT

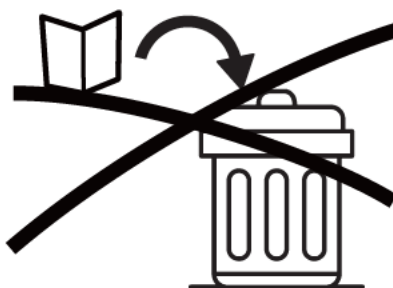
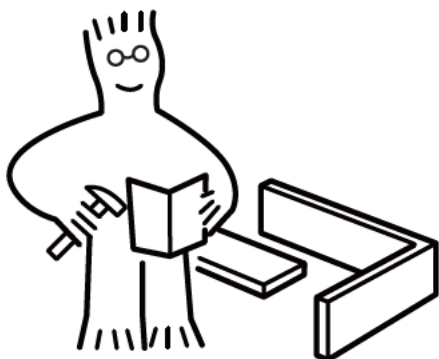

Assemble on a flat, clean and soft surface.  
Auf einer flachen, sauberen und weichen Oberfläche zusammenbauen.  
Assembler sur une surface plate, propre et douce.  
Assemblare su una superficie piatta, pulita e morbida.  
Ensamblar sobre una superficie plana, limpia y suave.

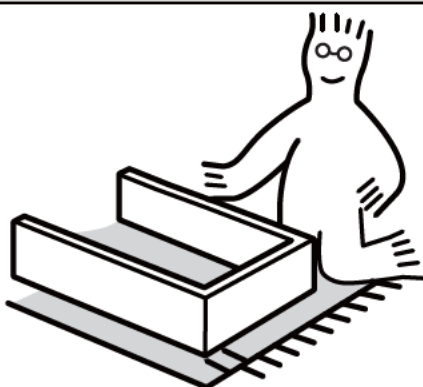

Professional installation is highly recommended.  
Eine professionelle Installation wird dringend empfohlen.  
Une installation professionnelle est fortement recommandée.  
Si raccomanda vivamente l'installazione professionale.  
Se recomienda altamente la instalación profesional.



Periodically Check That All Components Are Tightly Secured.  
Überprüfen Sie Regelmäßig, Dass Alle Komponenten Fest Gesichert Sind.  
Vérifiez Périodiquement Que Tous Les Composants Sont Bien Fixés.  
Controllare Periodicamente Che Tutti I Componenti Siano Ben Fissati.  
Verifique Periódicamente Que Todos Los Componentes Estén Bien Asegurados.



It is recommended that multiple people assemble this product.

Es wird empfohlen, dass mehrere Personen dieses Produkt zusammenbauen.

Il est recommandé que plusieurs personnes assemblent ce produit.

Si raccomanda che più persone assemblino questo prodotto.



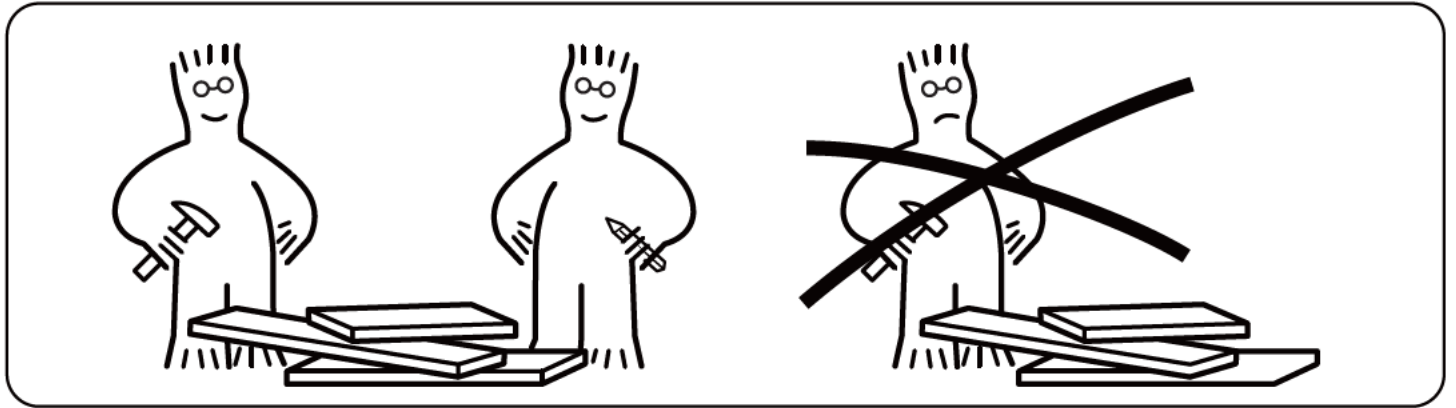



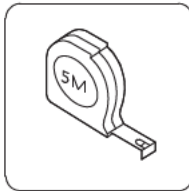
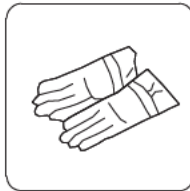
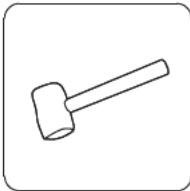
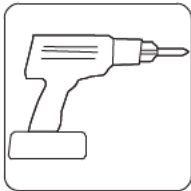

Se recomienda que varias personas ensamblen este producto.

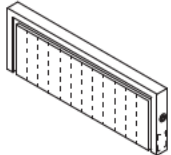











Please have the following auxiliary tools ready:







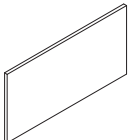
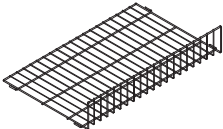
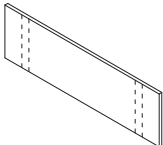
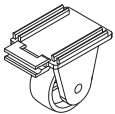
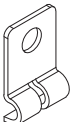
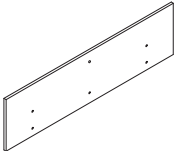
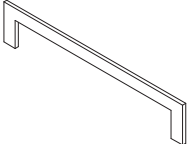



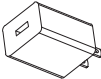

# PARTS

Item no. Nr. N° d'article Articolo No. Artículo No.	Reference Image Referenzbild Image de référence Immagine di riferimento Imagen de referencia	Qty. Menge Qté. Qtà Cant.
1		X1
2		X2
3		X1
4		X4
5		X4
6		X2
7		X2
8		X4

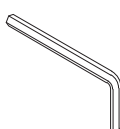
Item no. Nr. N° d'article Articolo No. Artículo No.	Reference Image Referenzbild Image de référence Immagine di riferimento Imagen de referencia	Qty. Menge Qté. Qtà Cant.
9		X2
10		X1
11		X2
12		X2
13		X2
14		X2
15		X10
16		X20

Item no. Nr. N° d'article Articolo No. Artículo No.	Reference Image Referenzbild Image de référence Immagine di riferimento Imagen de referencia	Qty. Menge Qté. Qtà Cant.
17		X4
18		X2
19		X2
20		X16
21		X4
22		X2
23		X1
24		X1

Item no. Nr. N° d'article Articolo No. Artículo No.	Reference Image Referenzbild Image de référence Immagine di riferimento Imagen de referencia	Qty. Menge Qté. Qtà Cant.
25		X1
26		X1
27		X1

Item no. Nr. N° d'article Articolo No. Artículo No.	Reference Image Referenzbild Image de référence Immagine di riferimento Imagen de referencia	Qty. Menge Qté. Qtà Cant.	Item no. Nr. N° d'article Articolo No. Artículo No.	Reference Image Referenzbild Image de référence Immagine di riferimento Imagen de referencia	Qty. Menge Qté. Qtà Cant.
(A)	 M8x16mm	X18	(G)	 M6x30mm	X6
(B)	 M8x50mm	X12		 S5	X1
(C)	 M8x18mm	X2		 S4	X1
(D)	 Ø8xØ22mm	X12			
(E)	 M8x35mm	X12			
(F)	 M6x10mm	X20			

# EXPLODED VIEW

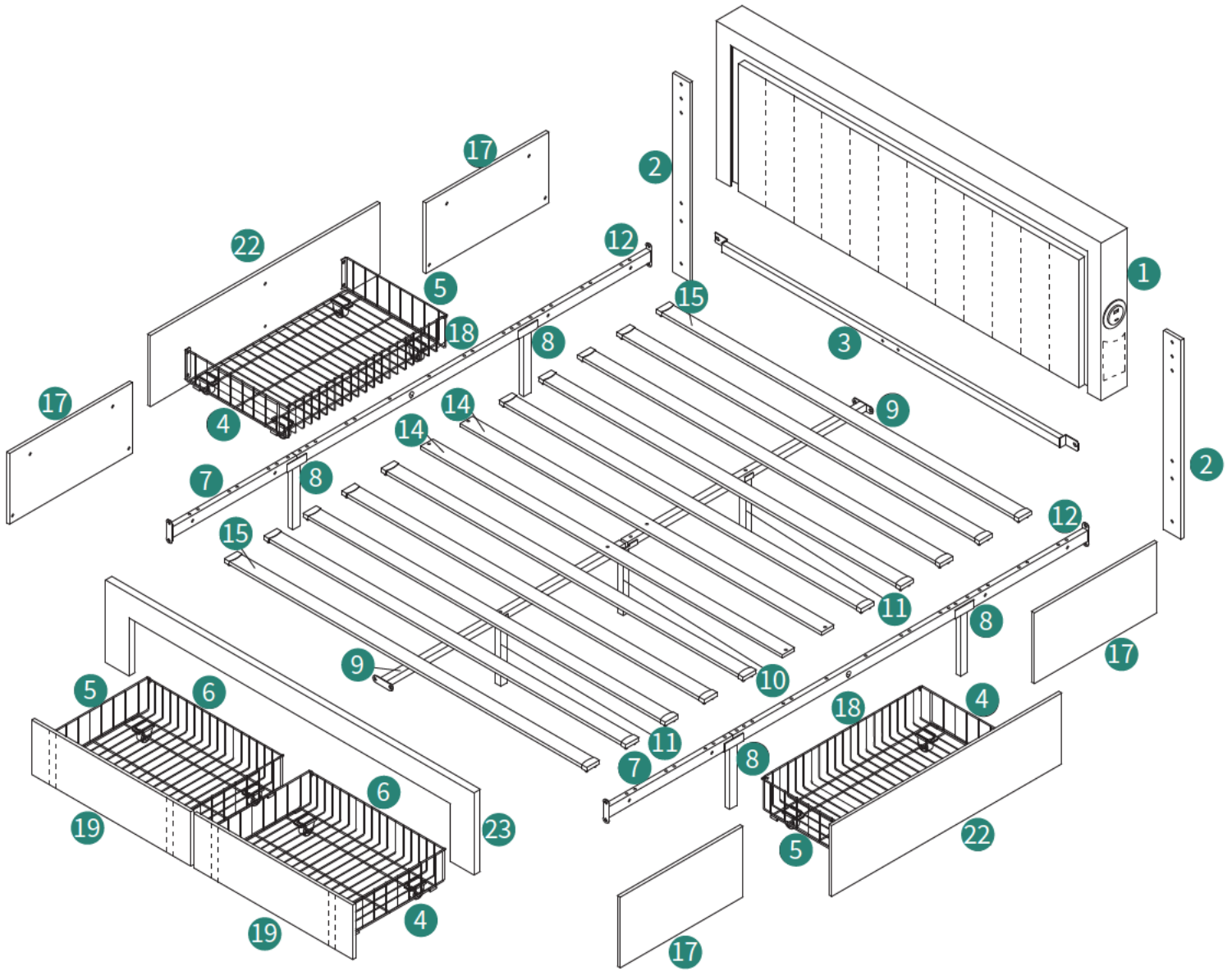

# ASSEMBLY

1

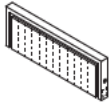

①x1



②5x1



②7x1



27

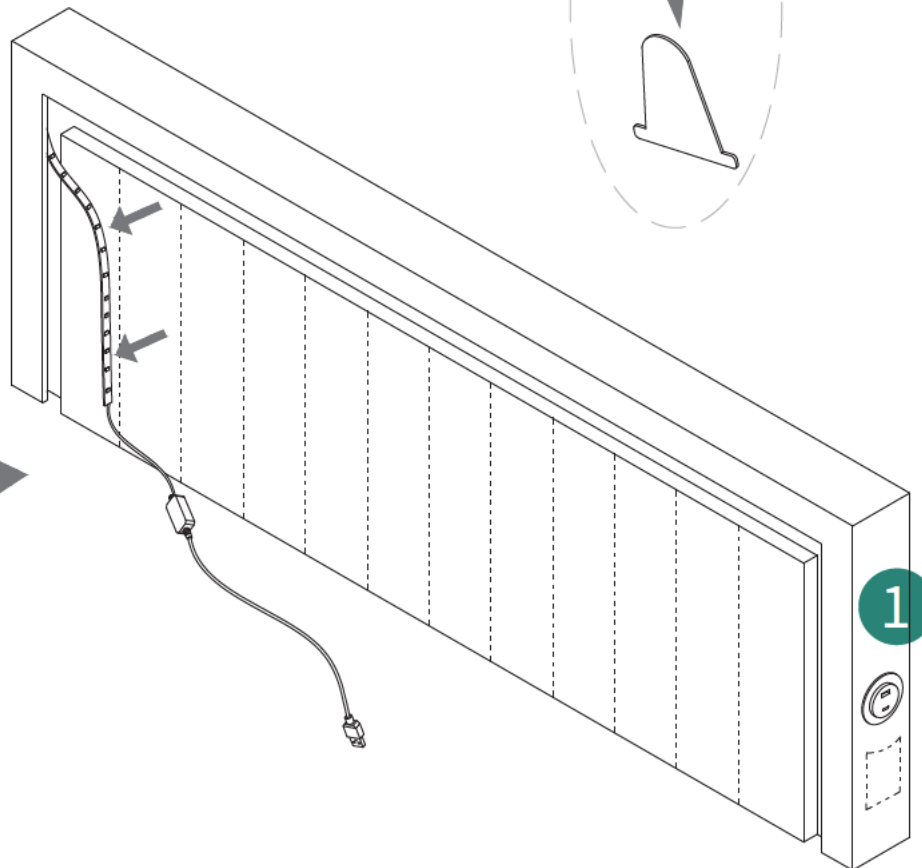
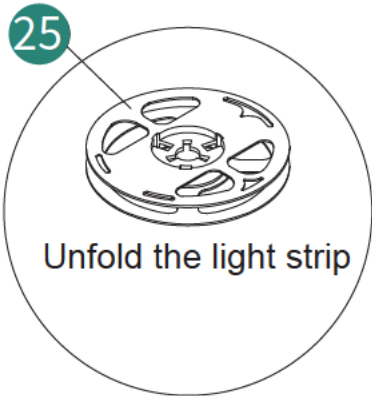
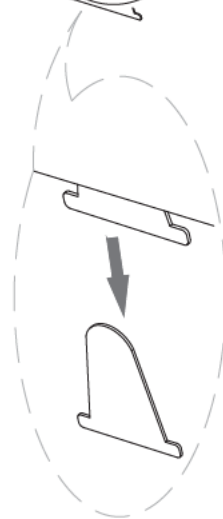

1

# 2



ⓑx4



ⓓx4



②x2

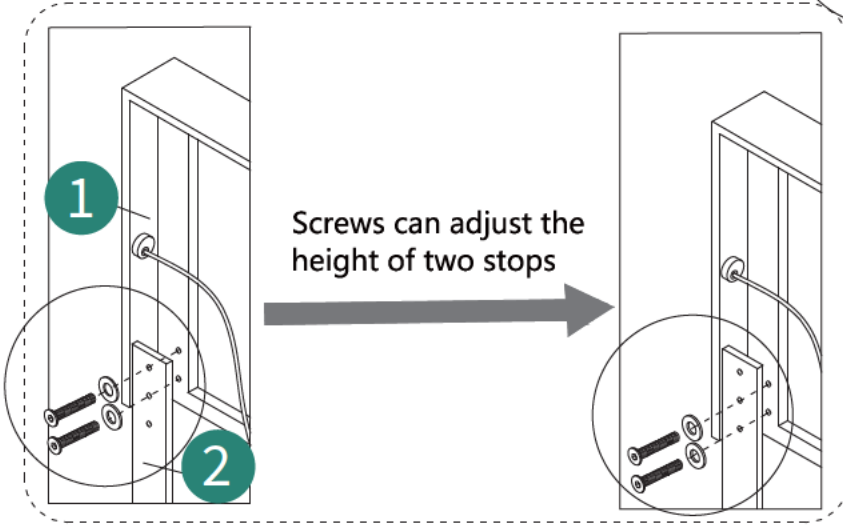
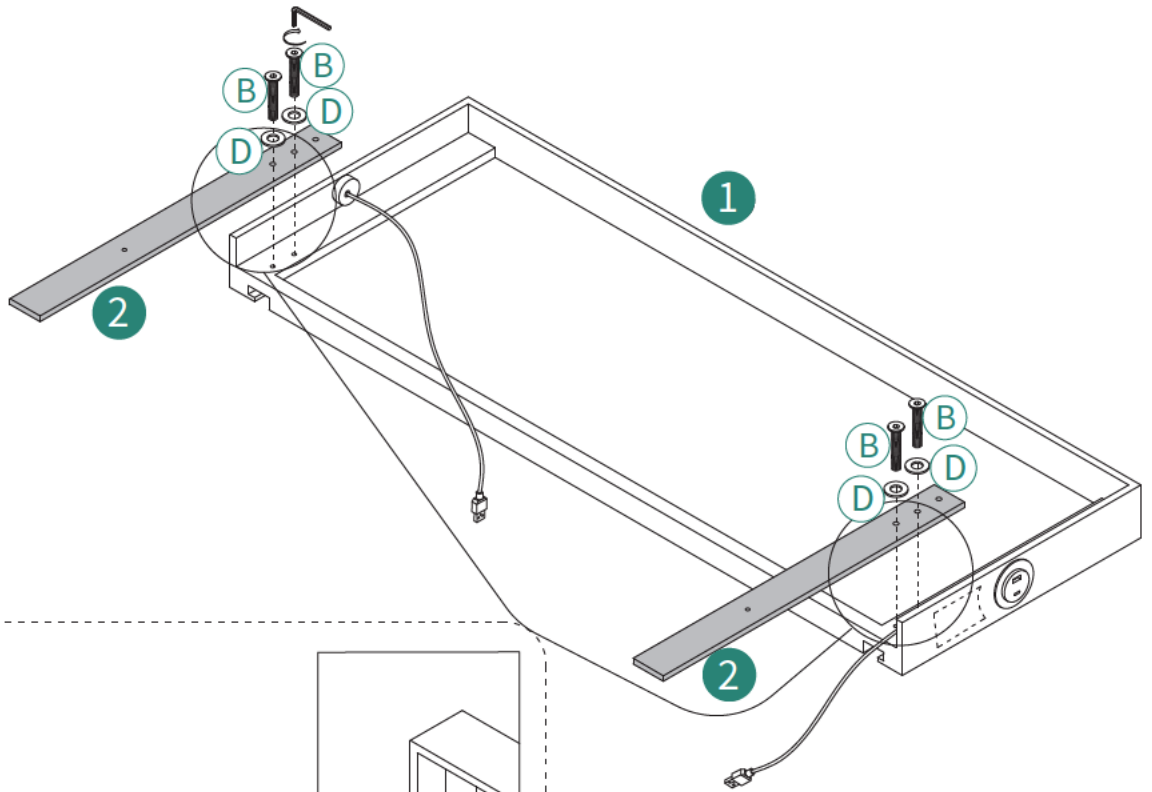

3



Ⓐx2



③x1

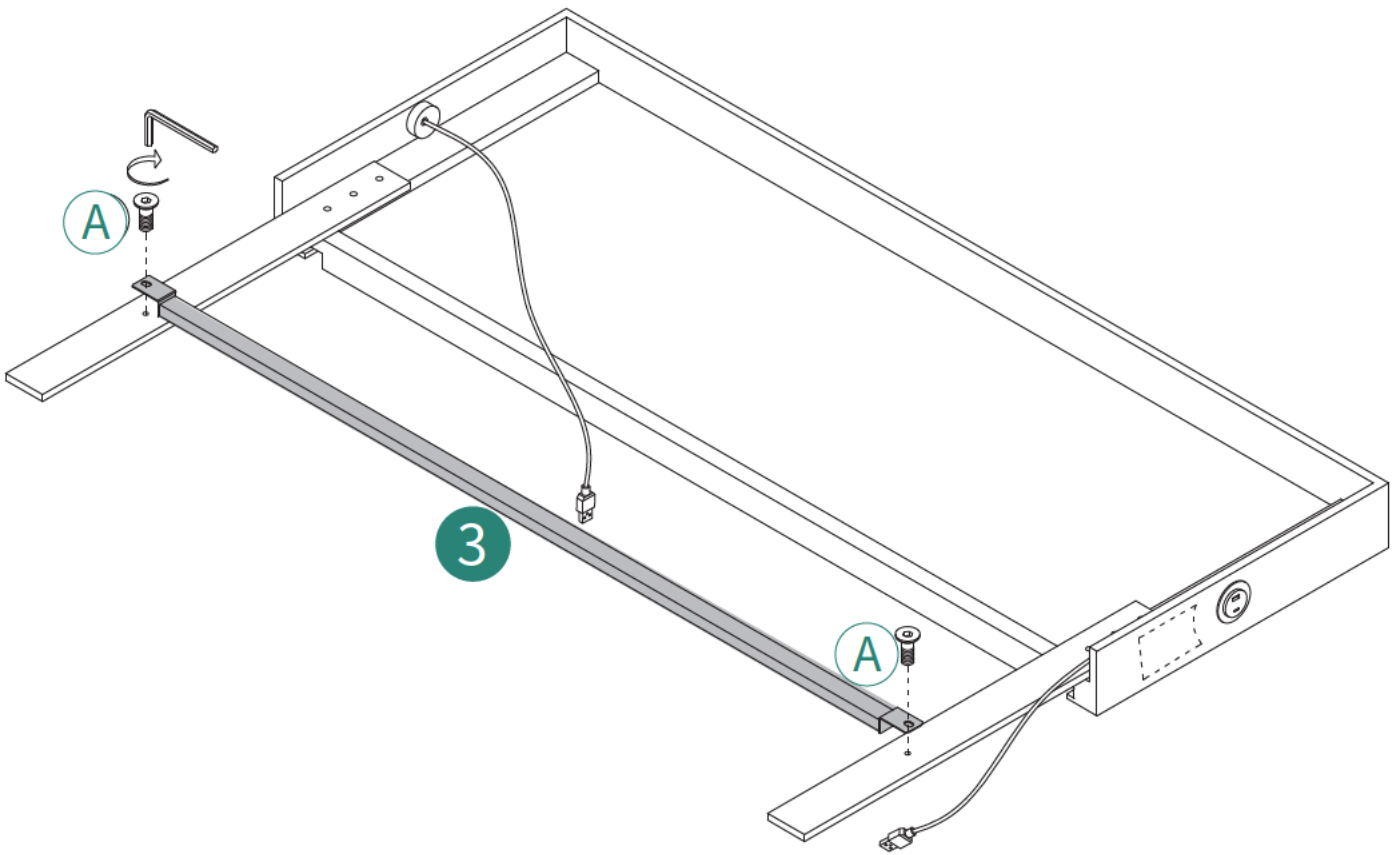

4

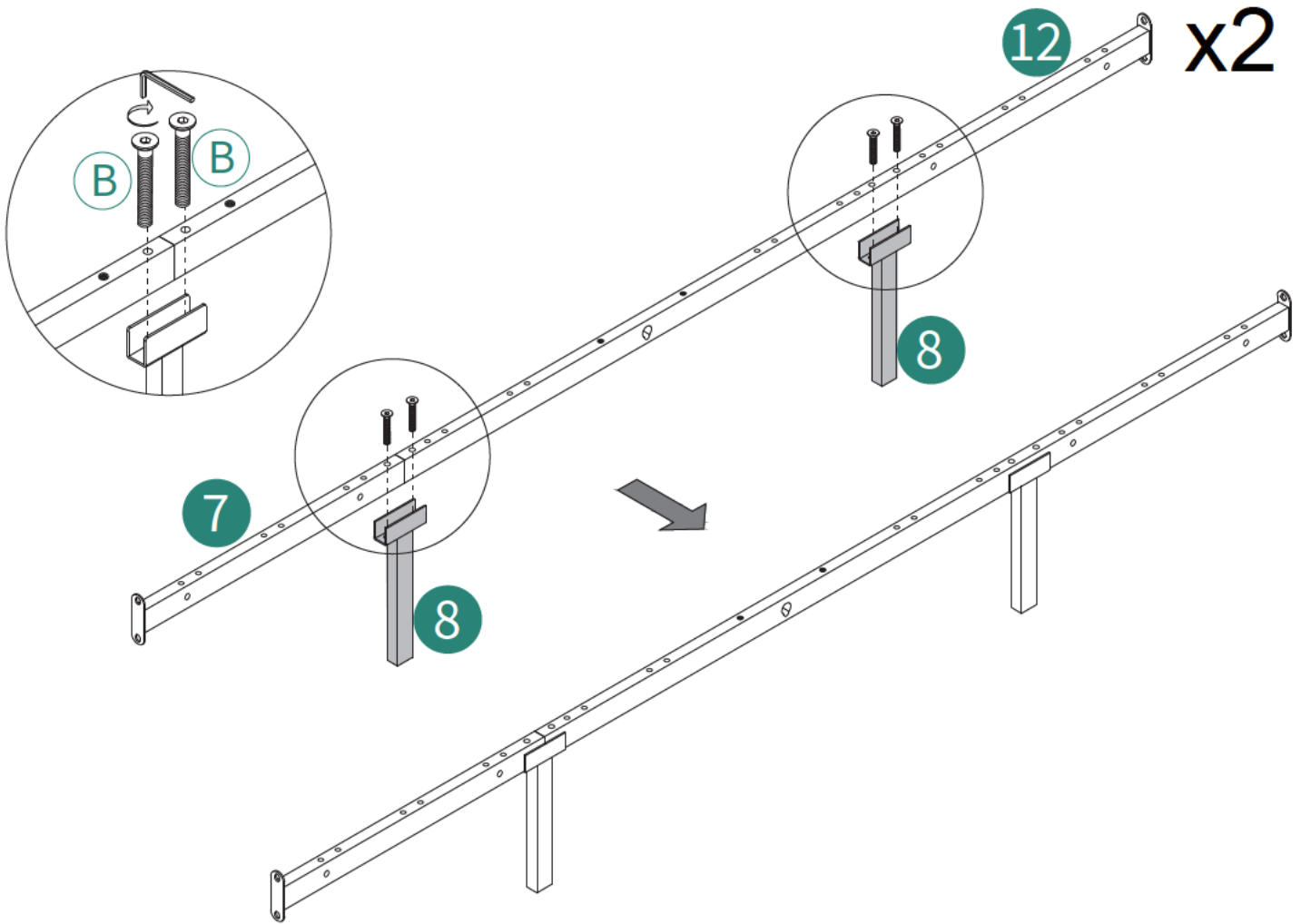
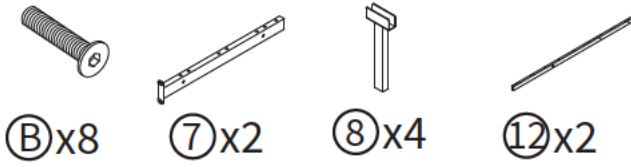

5



E x4



9 x2



10 x1



11 x2

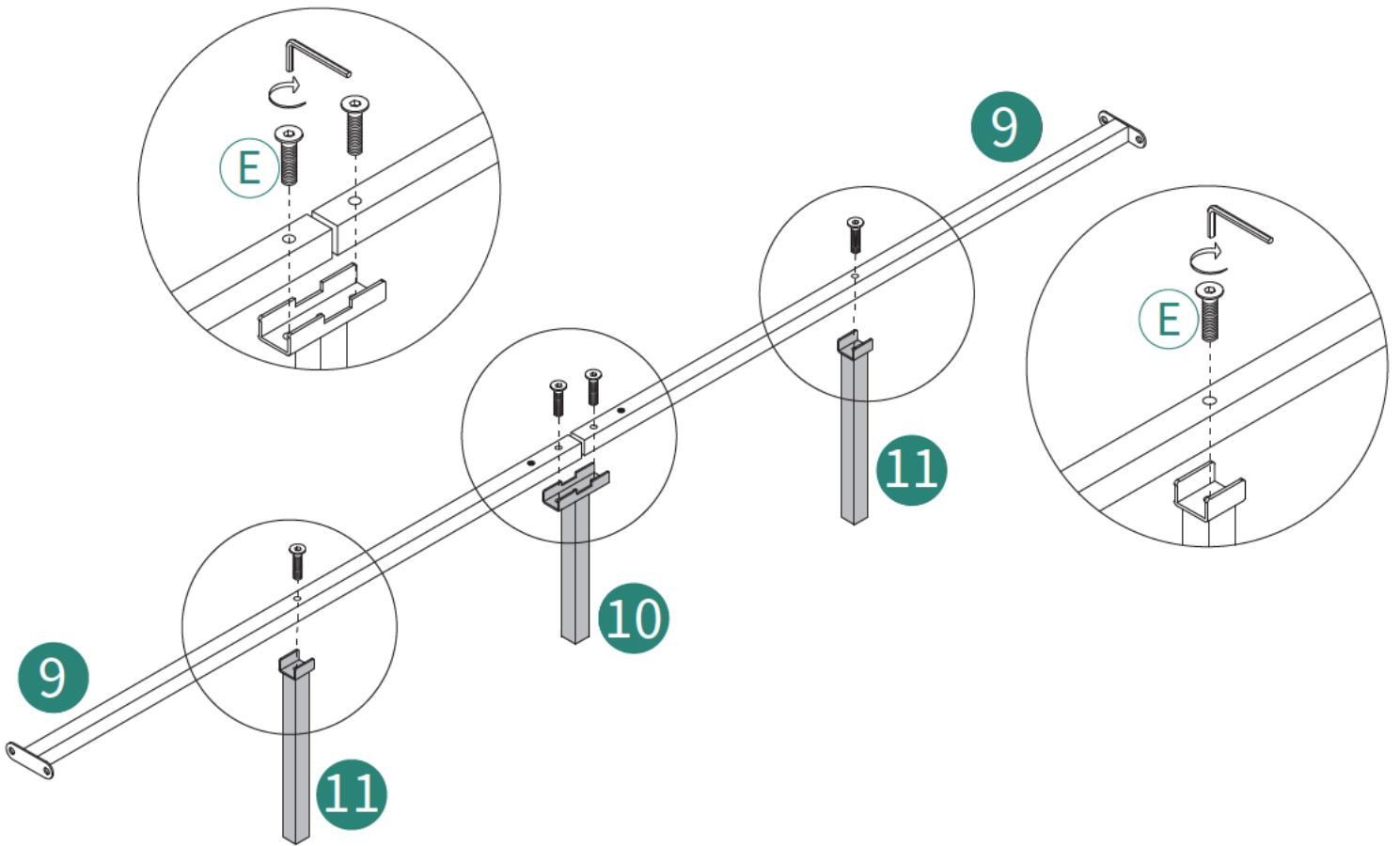

6

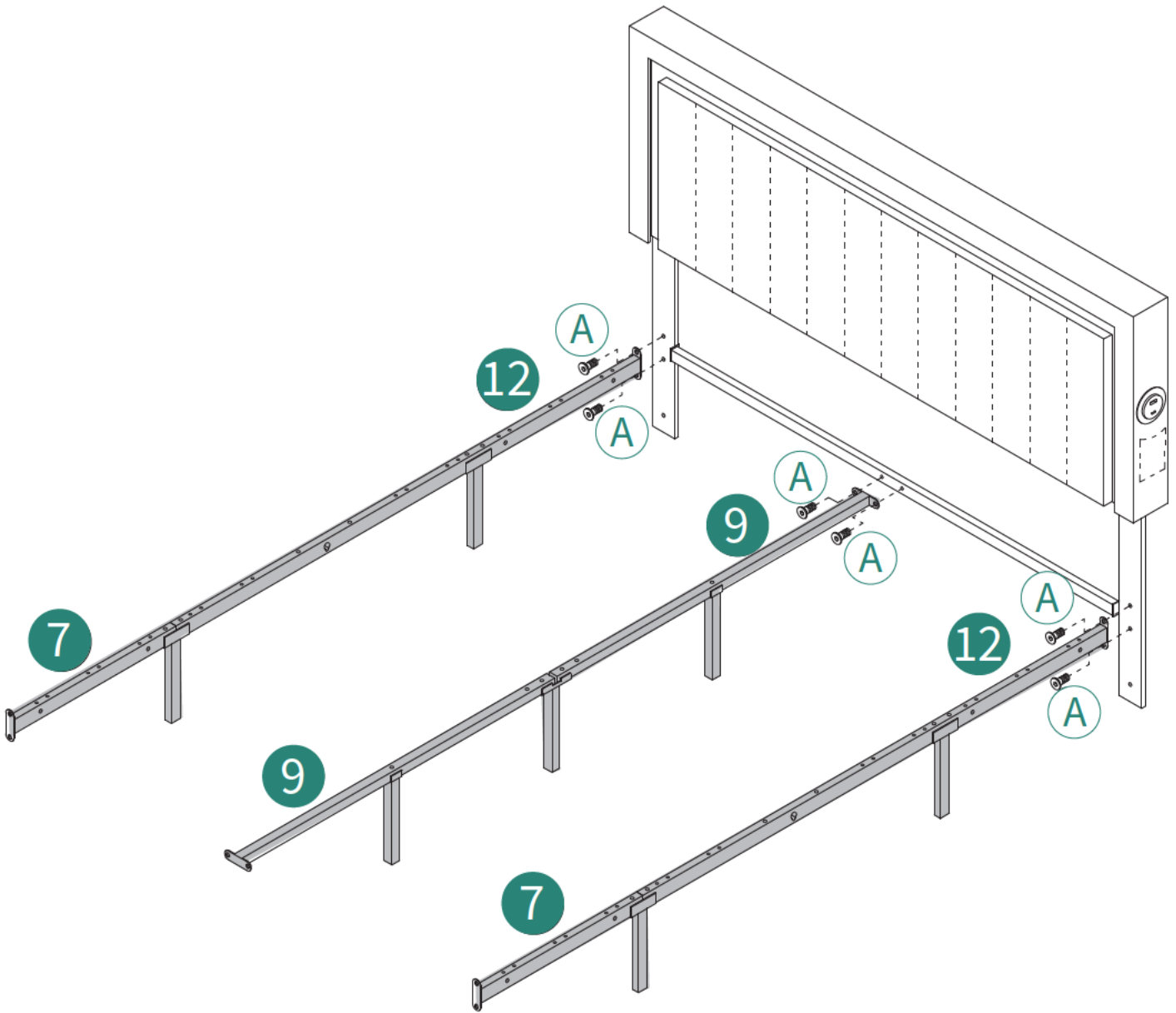
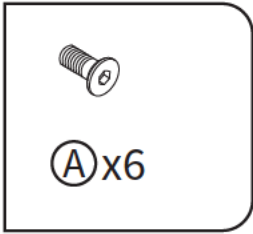

7



(A)x6

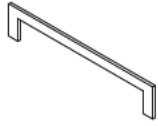

(23)x1



(24)x1



(26)x1

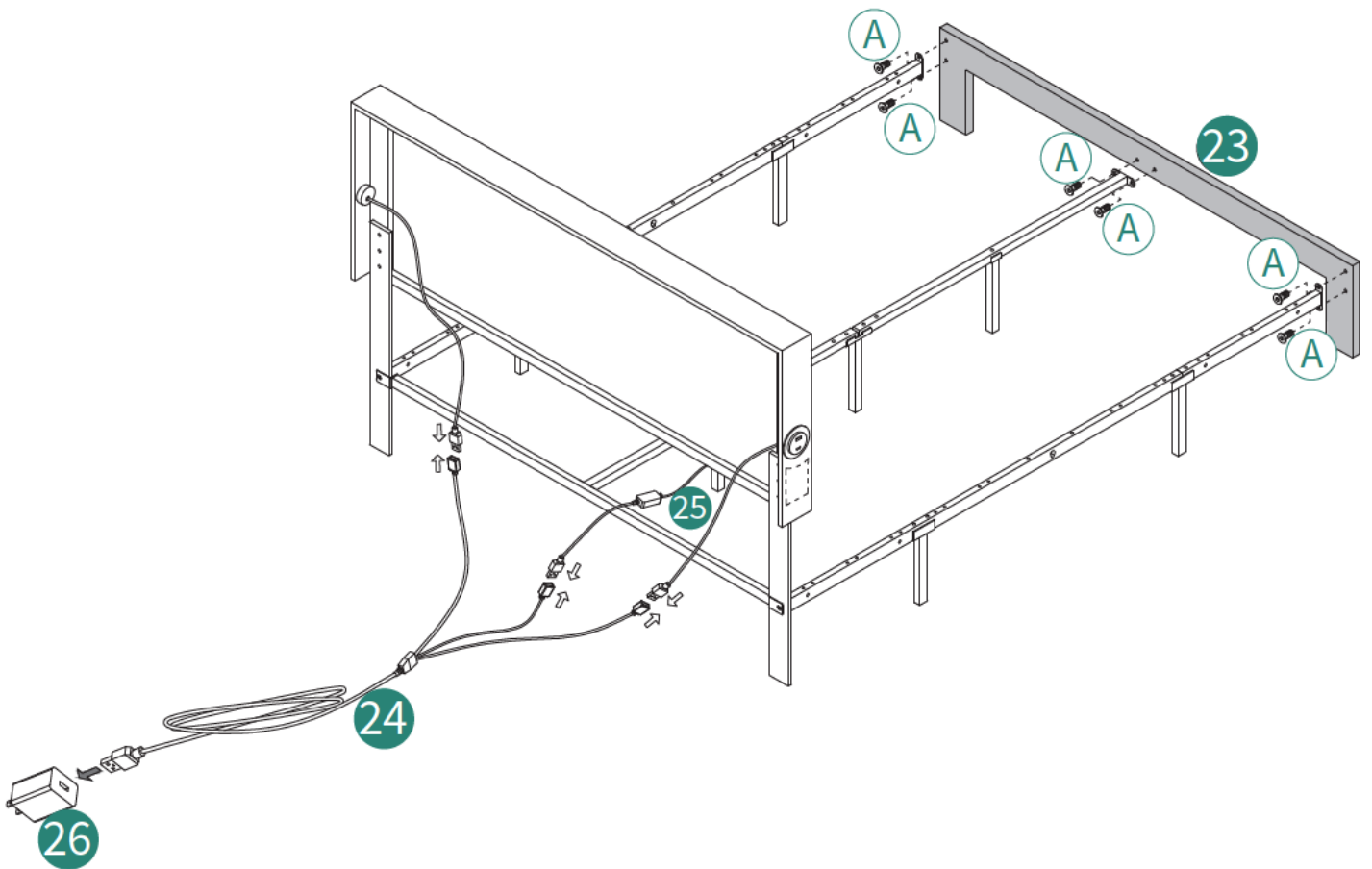

8



ⓔx8



ⓓx8

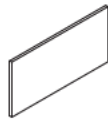

17x4

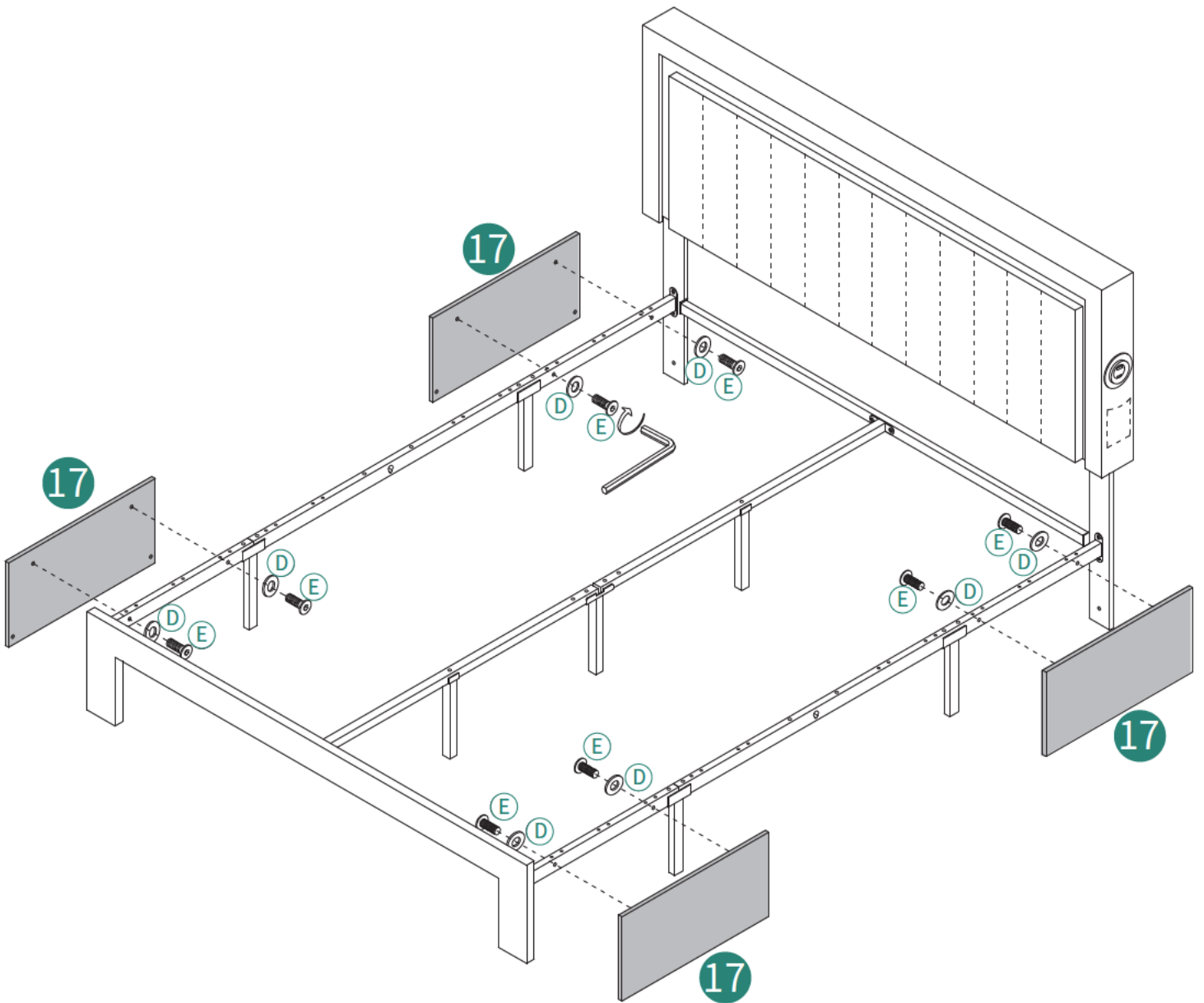

9

   
Ⓐx4 13x2

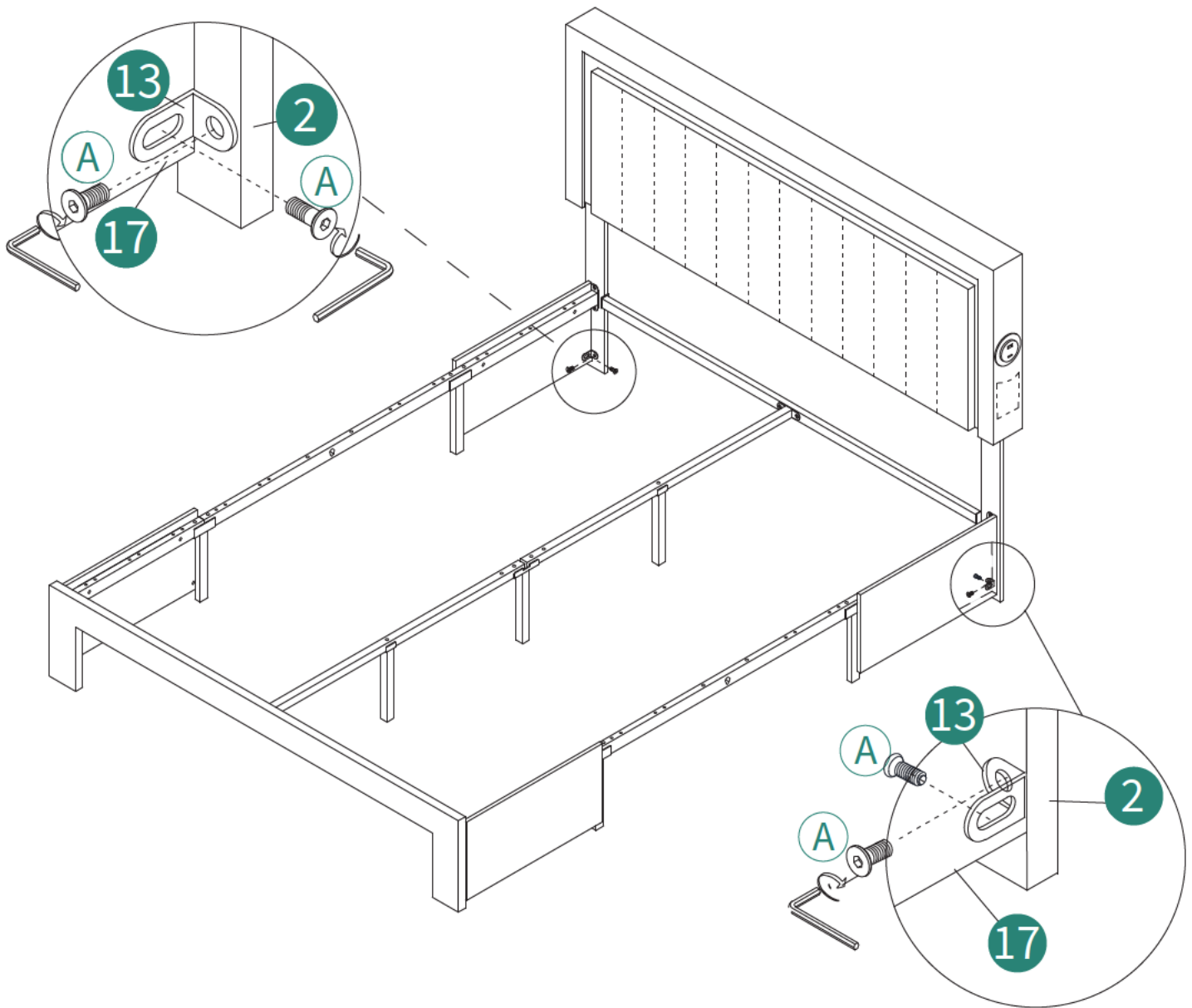

10

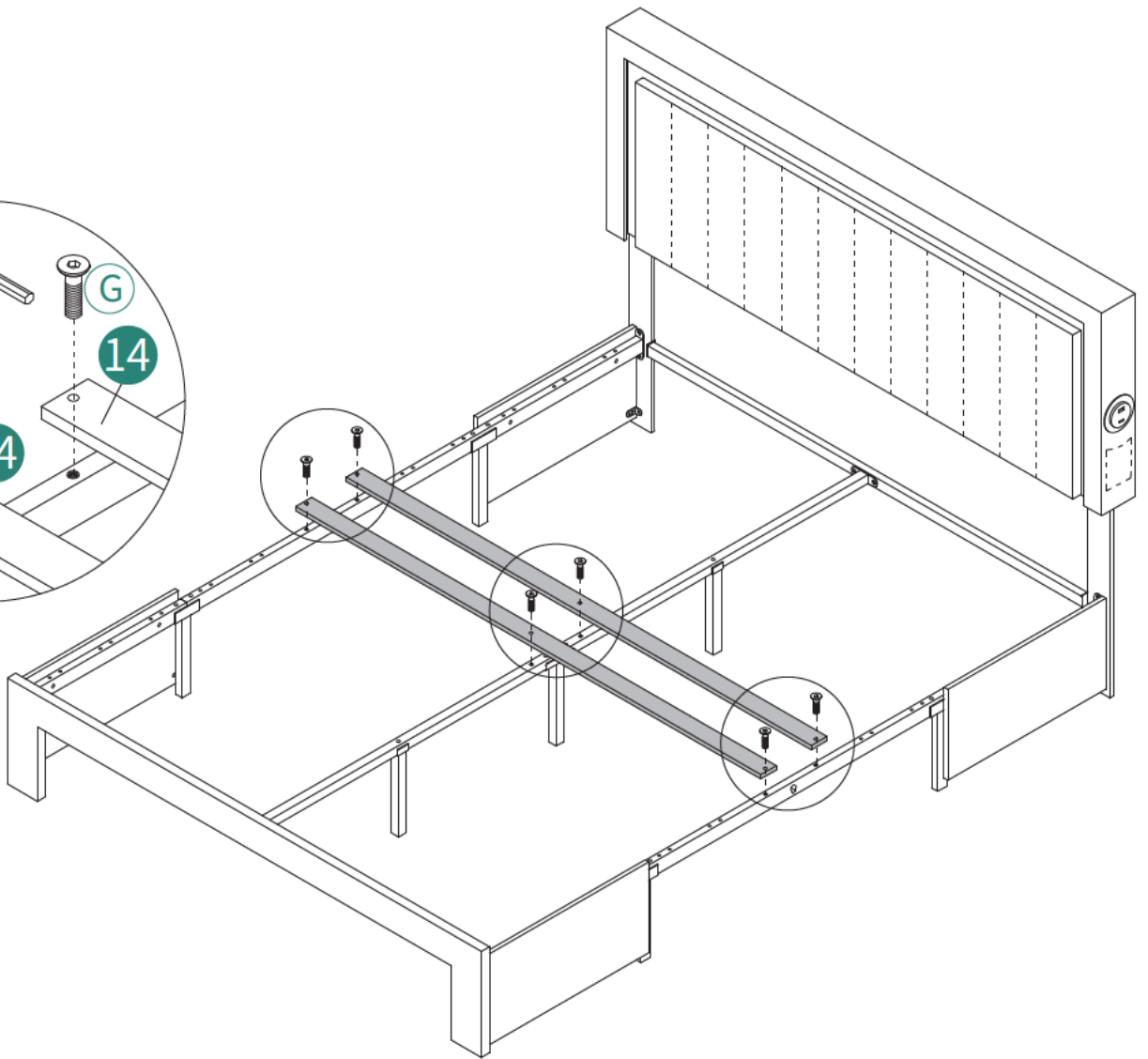
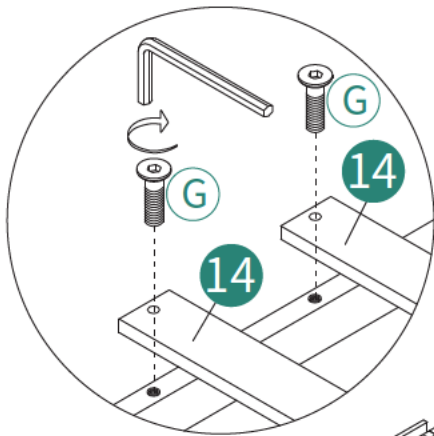
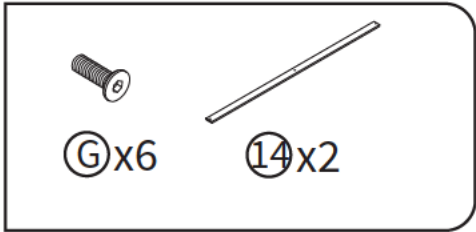

**11**

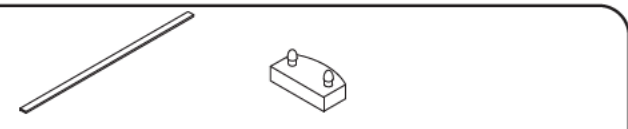

⑮x10      ⑯x20

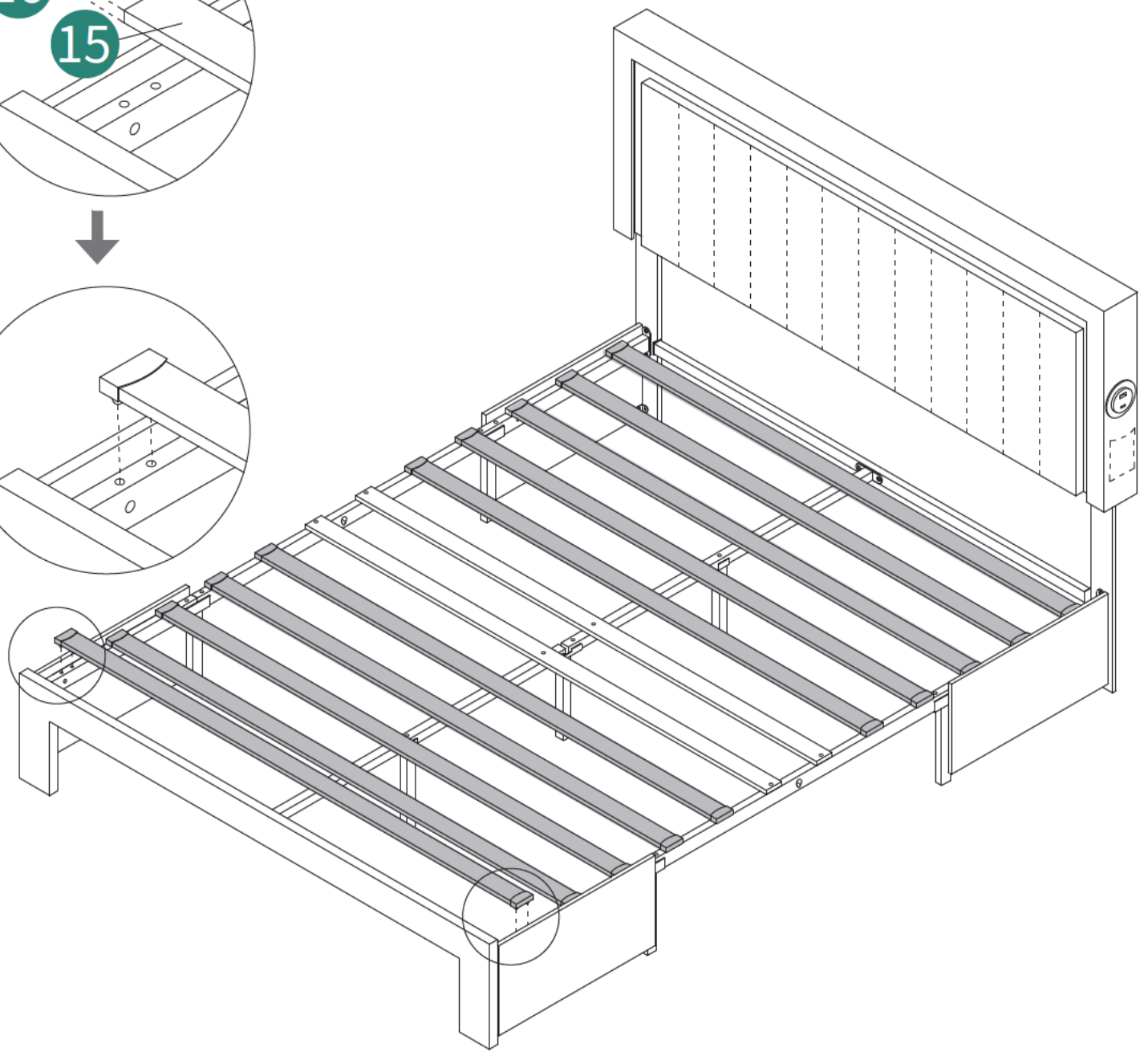
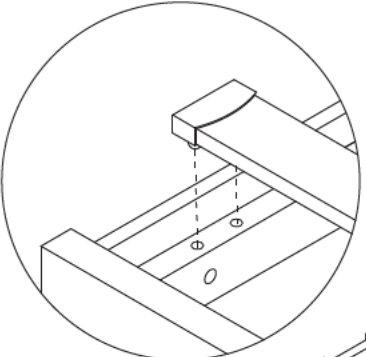
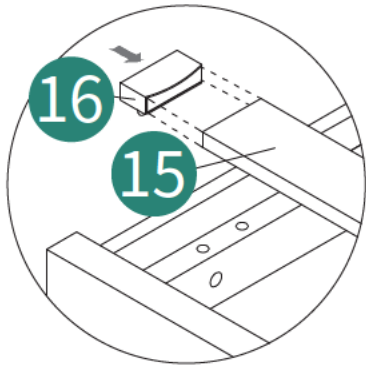

# 12

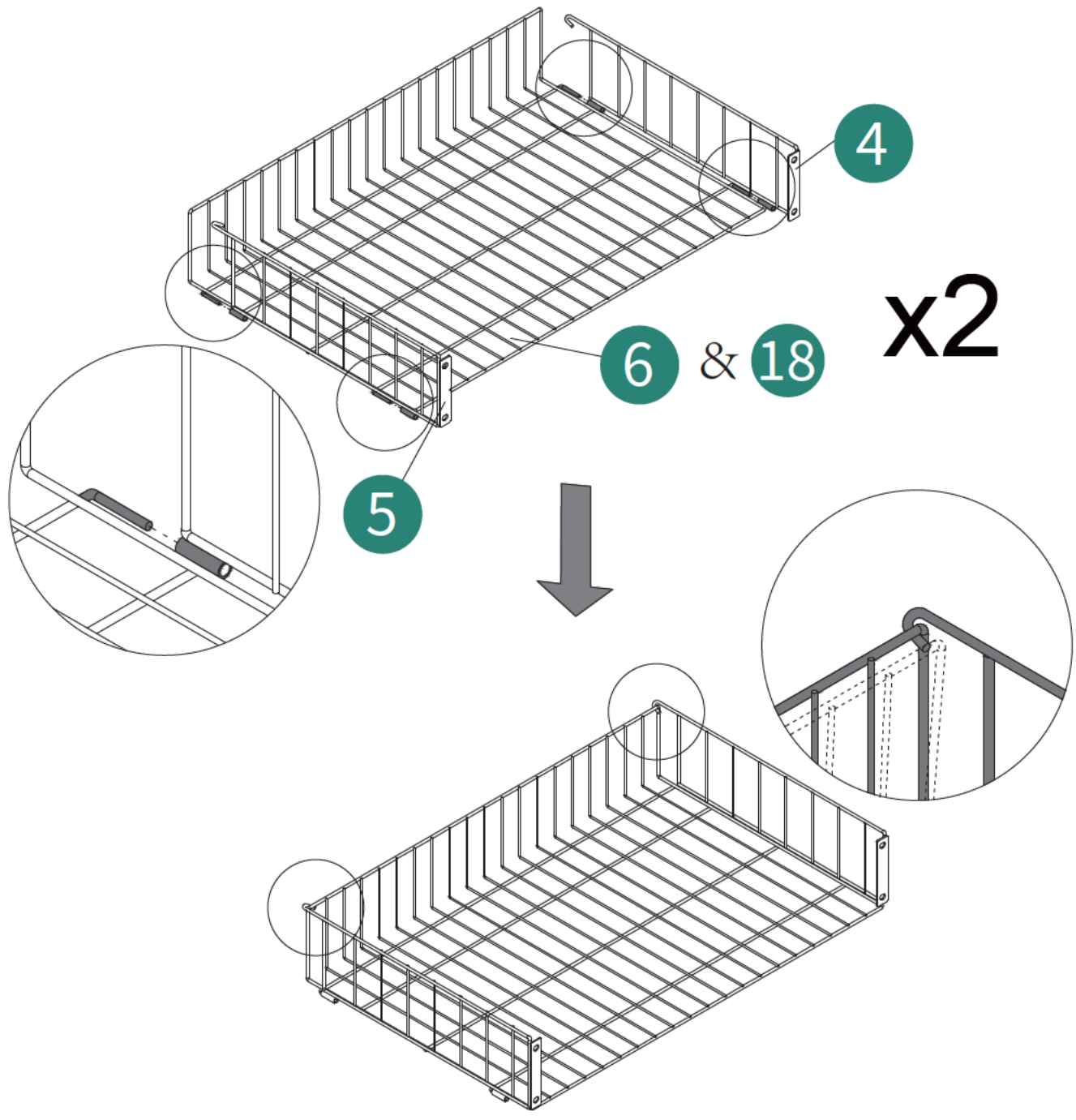
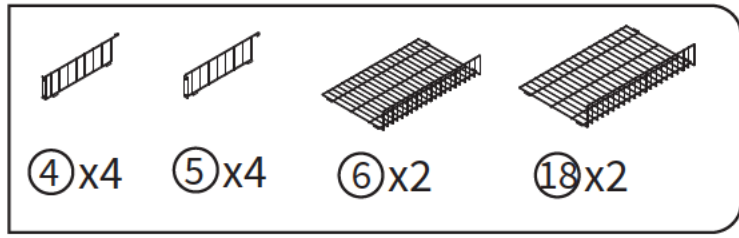

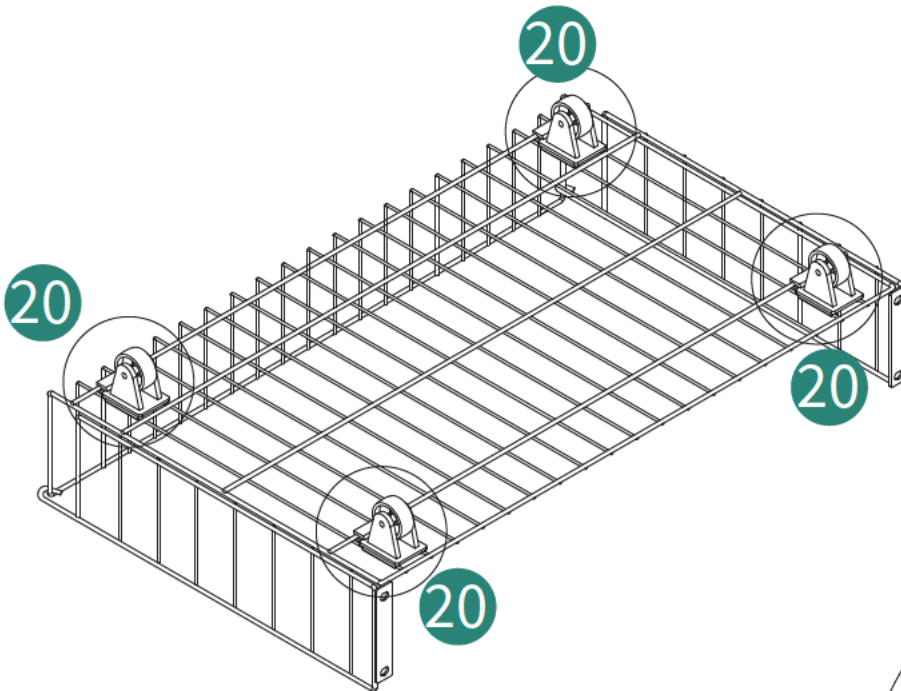
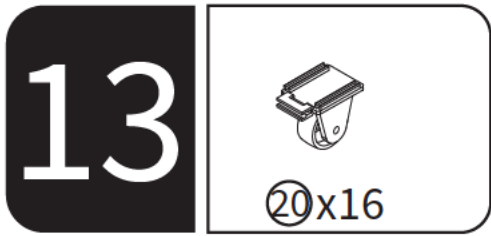

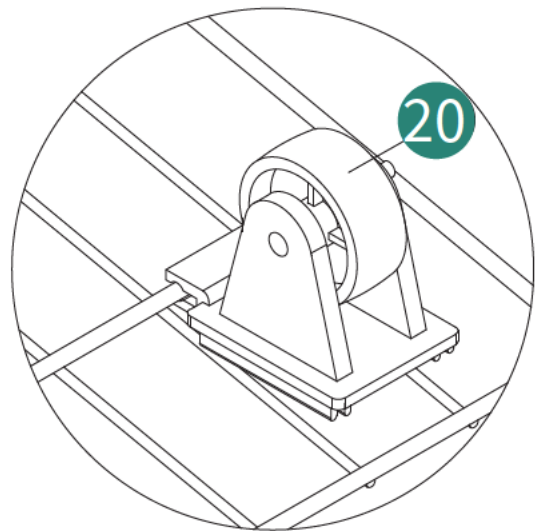

x4

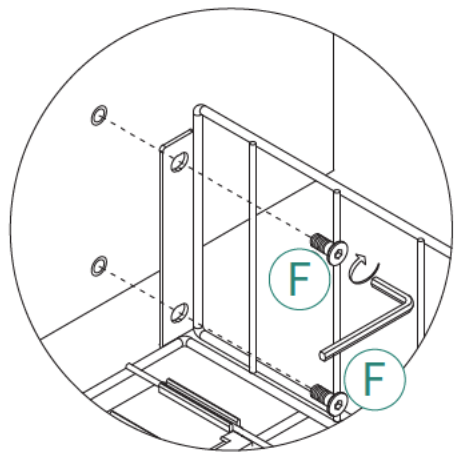
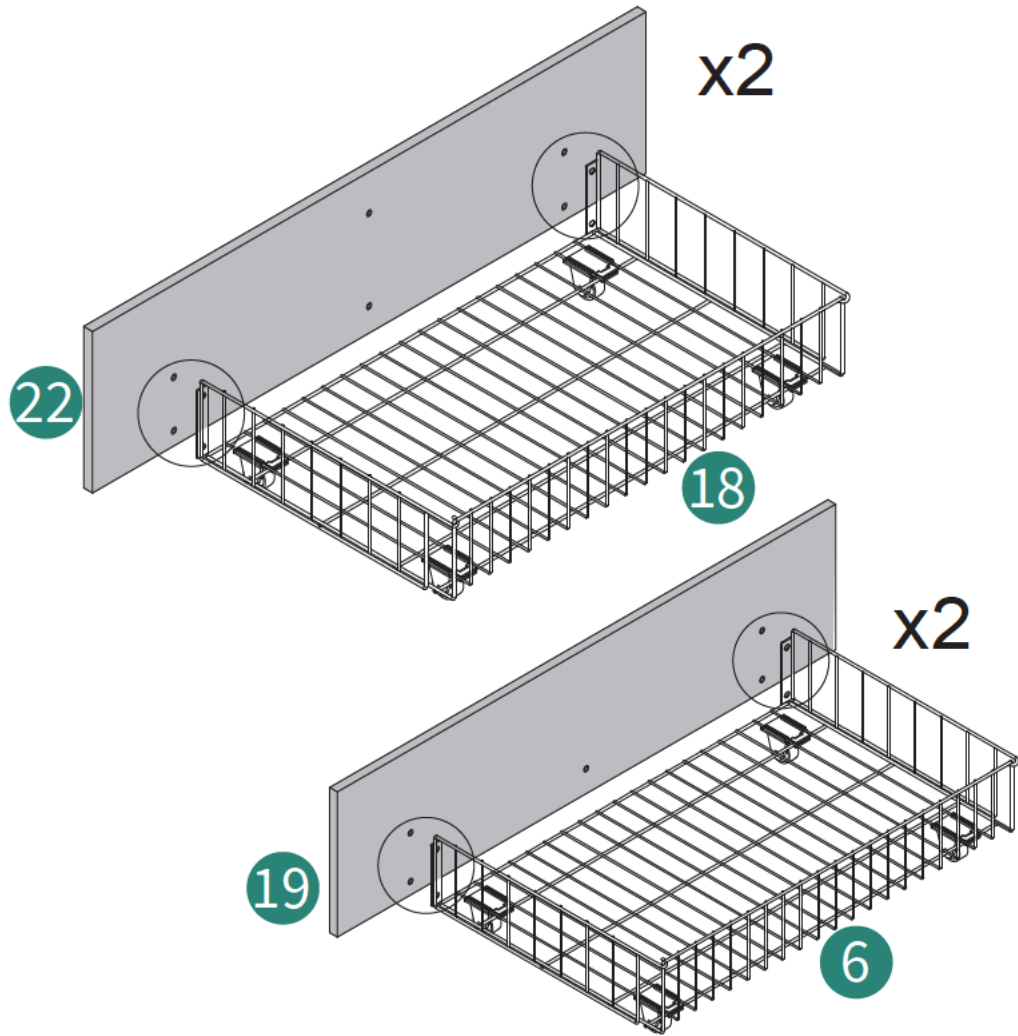
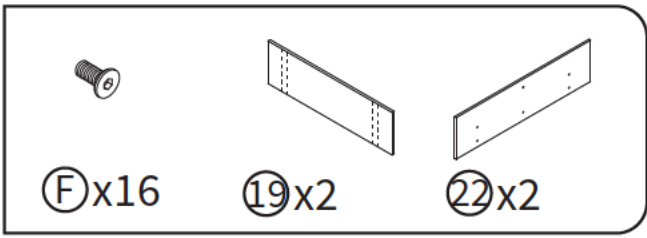

# 14

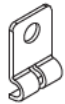

# 15

-  C x2
-  F x4
-  21 x4

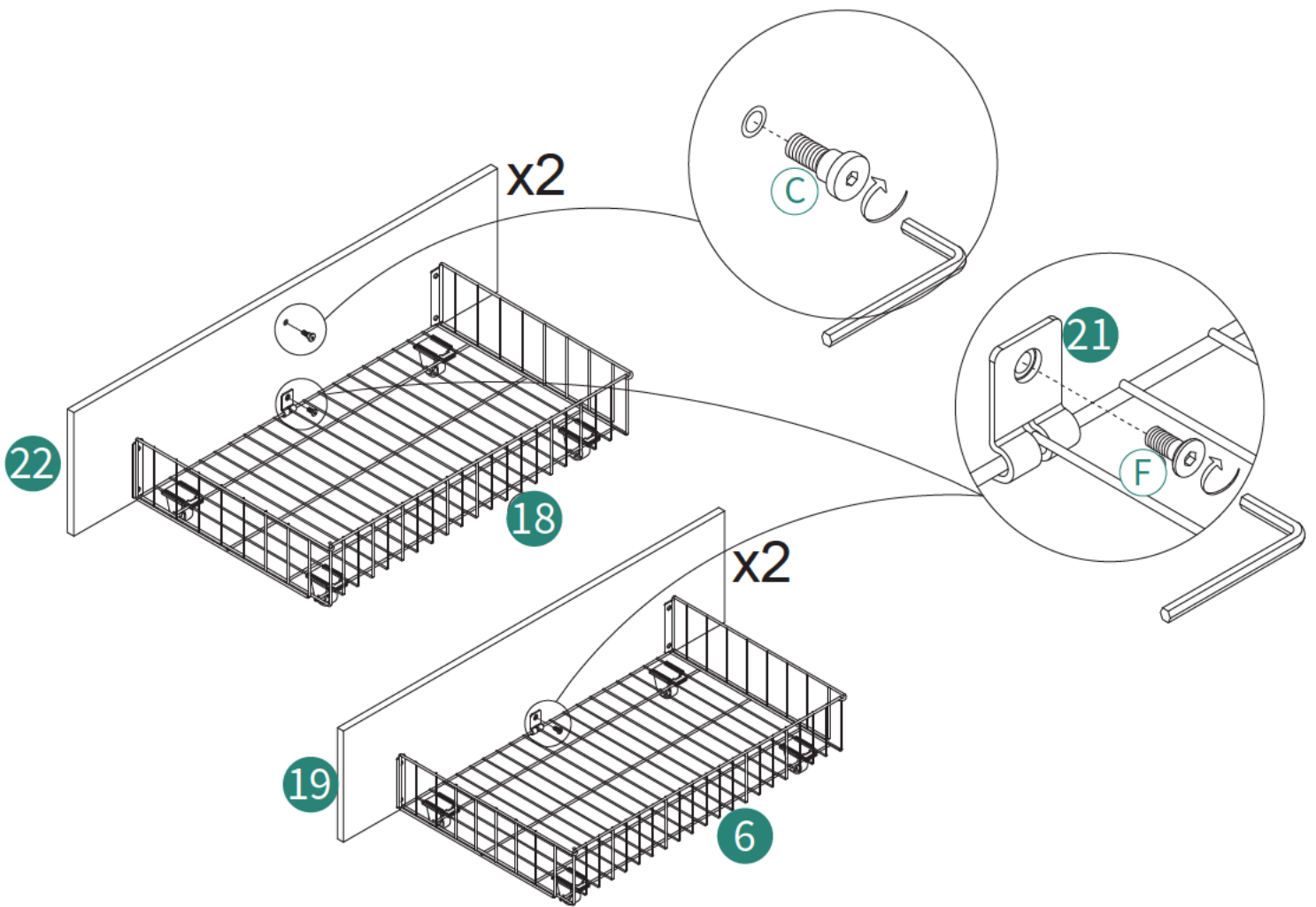

# 16

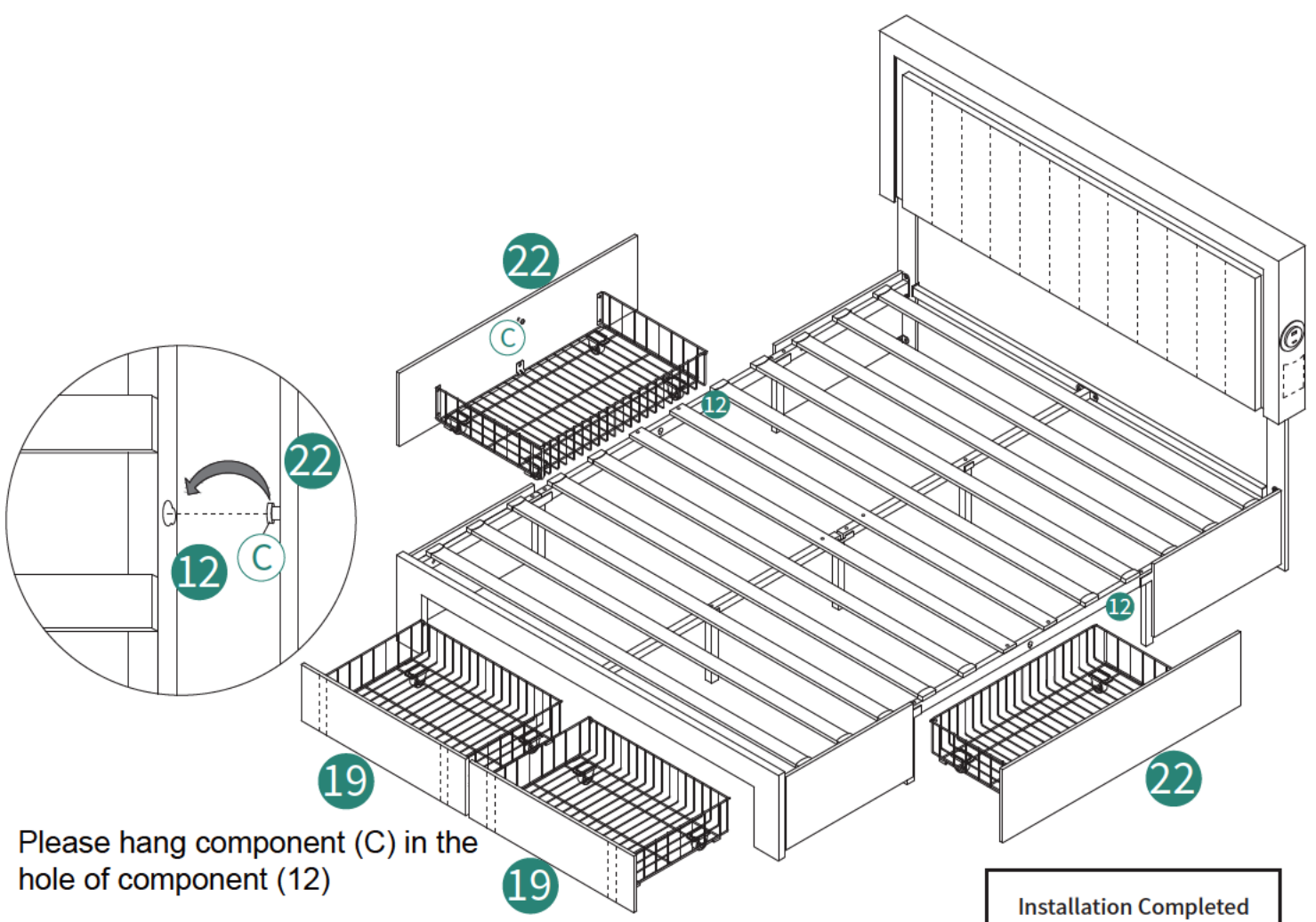

Please hang component (C) in the hole of component (12)

- Installation Completed
- Installation Abgeschlossen
- Installation Complétée
- Installazione Completata
- Instalación Completada

# HELP CENTER



Inquiry



Assembly issue



Missing parts

If you encounter any difficulties during assembly, please contact us.

Wenn Sie während der Montage auf Schwierigkeiten stoßen, kontaktieren Sie uns bitte.

Si vous rencontrez des difficultés lors du montage, veuillez nous contacter.

Se incontri difficoltà durante il montaggio, ti preghiamo di contattarci.

Si encuentras alguna dificultad durante el ensamblaje, por favor contáctanos.

# DISCLAIMER

Manufacturer and seller expressly disclaim any and all liability for personal injury, property damage or loss, whether direct, indirect, or incidental, resulting from the incorrect attachment, improper use, inadequate maintenance, unapproved modification, or neglect of this product.

Der Hersteller und Verkäufer lehnen ausdrücklich jegliche Haftung für Personenschäden, Sachschäden oder Verluste ab, egal ob direkt, indirekt oder zufällig, die durch falsche Anbringung, unsachgemäßen Gebrauch, unzureichende Wartung, nicht genehmigte Änderungen oder Vernachlässigung dieses Produkts entstehen.

El fabricante y vendedor renuncian expresamente a toda responsabilidad por lesiones personales, daños materiales o pérdidas, ya sean directos, indirectos o incidentales, derivados de la incorrecta colocación, uso inadecuado, mantenimiento insuficiente, modificación no aprobada o negligencia de este producto.

Il produttore e il venditore declinano espressamente ogni responsabilità per lesioni personali, danni materiali o perdite, dirette, indirette o incidentali, derivanti dall'errato fissaggio, uso improprio, manutenzione inadeguata, modifica non autorizzata o negligenza di questo prodotto.

Le fabricant et le vendeur déclinent expressément toute responsabilité en cas de blessures corporelles, de dommages matériels ou de pertes, qu'ils soient directs, indirects ou accessoires, résultant de la fixation incorrecte, de l'utilisation inappropriée, de l'entretien insuffisant, de la modification non approuvée ou de la négligence de ce produit.