

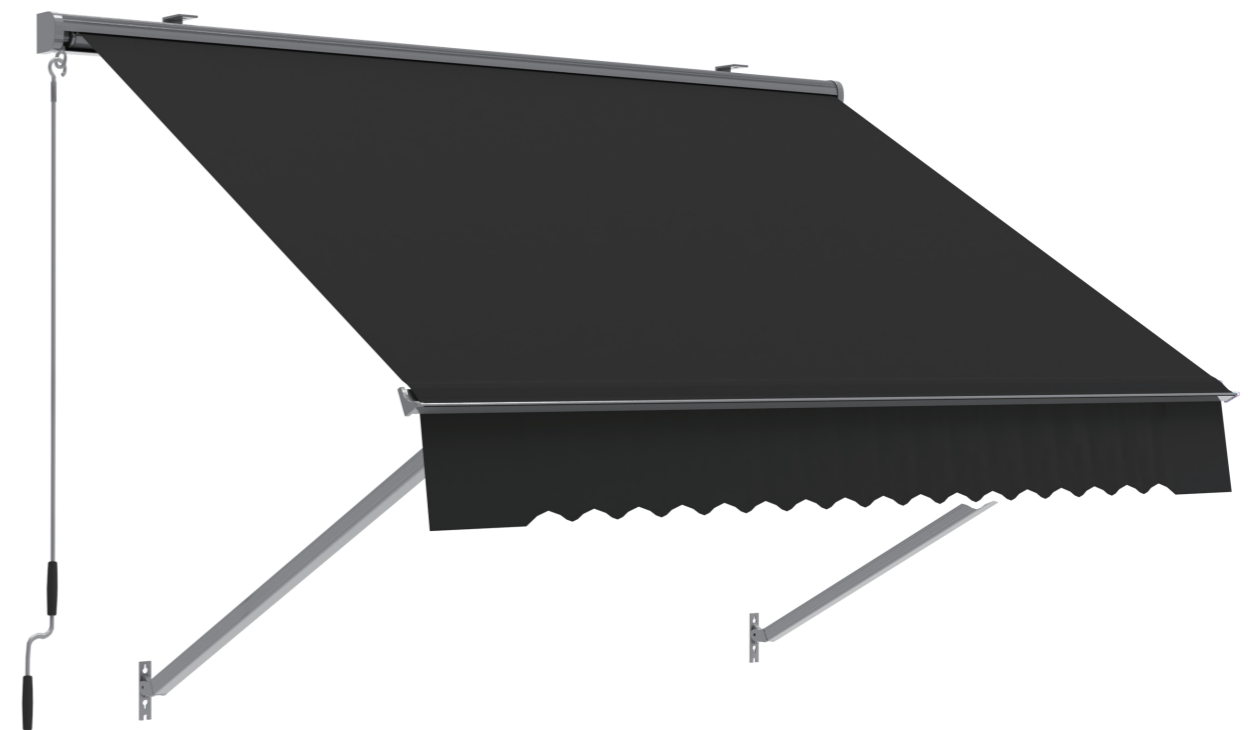

macrout



OWNER'S MANUAL

# WINDOW AWNING

amazon



Amazon.com/macrou

v1.0.0

Newacme LLC, 2411 Bear Corbitt Rd STE 1 New Castle, DE, 19720  
sales@macrou.com

(302) 268-8644 (8:00 a.m. - 4:00 p.m. (Monday - Friday) TIME ZONE: PST)

NEWACME LLC sales@macrou.com

6055-WA412/416/418

Hello,  
Thank you for choosing our product  
Let's get started.

#### ○ PURCHASER'S AGREEMENT

By accepting delivery of this product, you promise that you will not change, alter, or modify this product or remove or render inoperable or unsafe any guards, shields or other safety features of this product.

You will not refuse or neglect any retrofit kits that macrout may provide to enhance and preserve the safe use of this product.

# CONTENTS

<b>I</b>	<b>SAFETY GUIDELINES</b>	- 01
<b>II</b>	<b>MAINTENANCE</b>	- 02
<b>III</b>	<b>ASSEMBLY INSTRUCTIONS</b> <ul style="list-style-type: none"><li>• Preparation</li><li>• Part List</li><li>• Parts Exploded View</li><li>• Assembly Steps</li></ul>	- 02
<b>IV</b>	<b>WARRANTY</b>	- 10
<b>V</b>	<b>RETURN / REPLACEMENT POLICY</b>	- 11
<b>VI</b>	<b>MACROUT CUSTOMER SUPPORT</b>	- 12

# I. SAFETY GUIDELINES

**⚠ WARNING**

For your own safety, please strictly follow the instructions in this manual, otherwise personal injury may result!

Before you proceed, please read the following safety precautions:

- The Macrout window awning should only be operated by an adult that understands all the functions and operations of the awning. Please keep unsupervised children away from playing with the awning or its parts.
- The product should be used only as described in this Macrout window awning manual.
- Do not carry out any maintenance other than what is shown in this manual. For any issues that are not covered in this manual, please seek support from Macrout Customer Service.

# II. MAINTENANCE

- Do not use bleach, acid, or other solvents on the fabric or frame parts.
- Please inspect and tighten all bolts or fasteners on a regular basis to ensure proper performance and safety of your awning.

# III. ASSEMBLY INSTRUCTIONS

## 1. Preparation

- Please remove all protective materials. Before assembling, make sure that you lay out and identify all parts listed below in the parts list. install on level ground.
- Please prepare all the necessary tools.

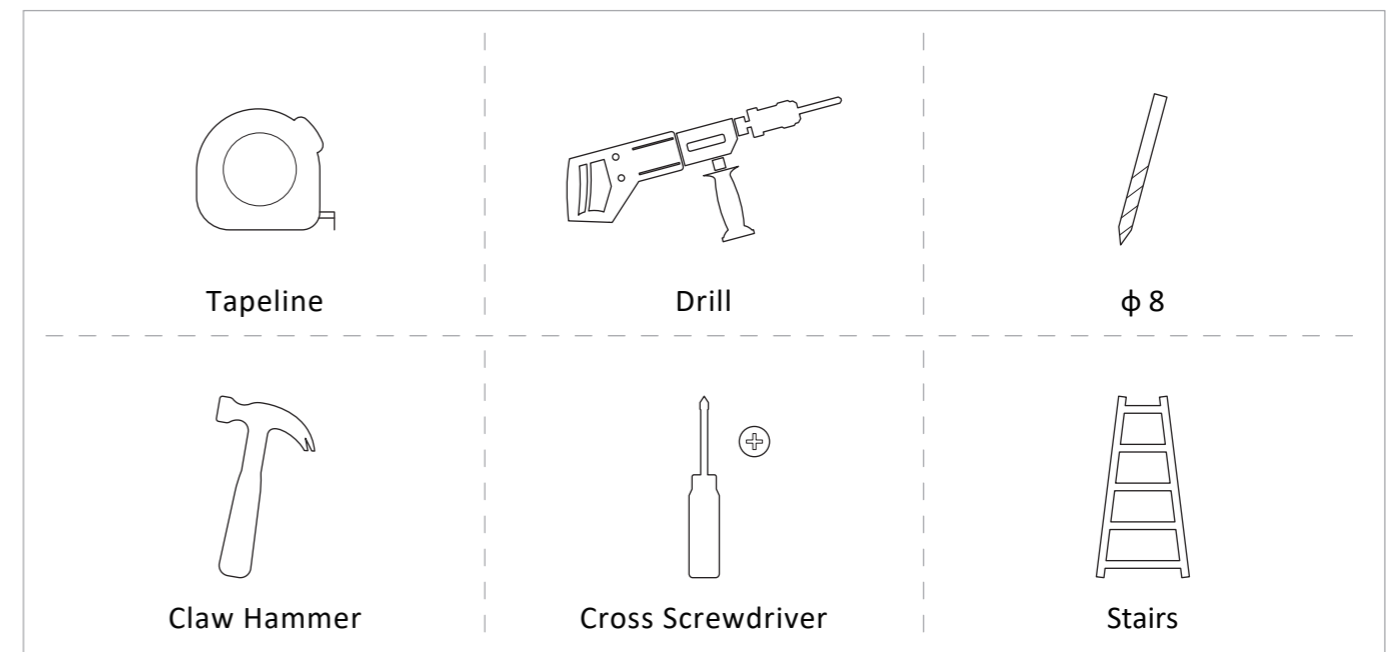

## 2. Part List

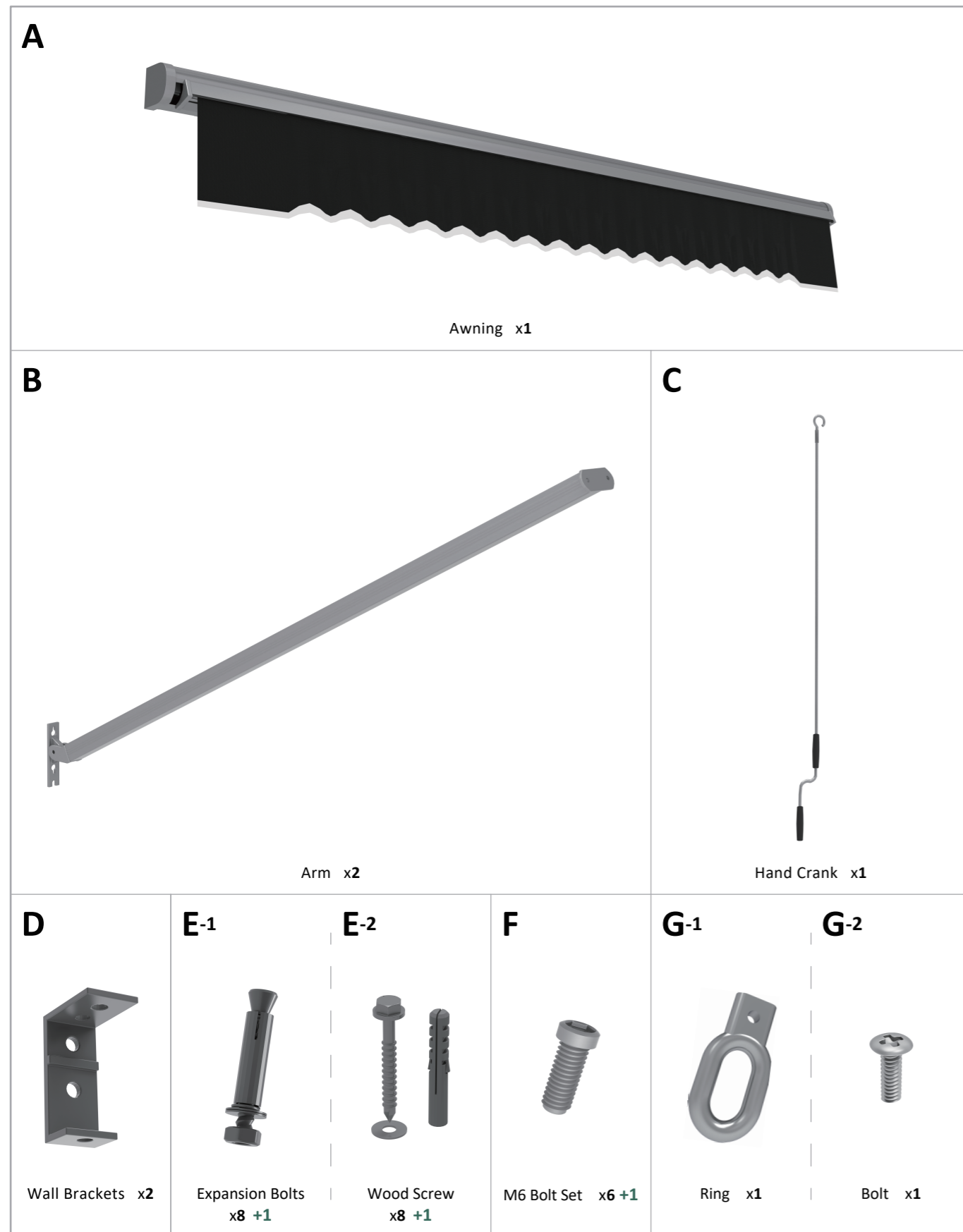

## 3. Parts Exploded View

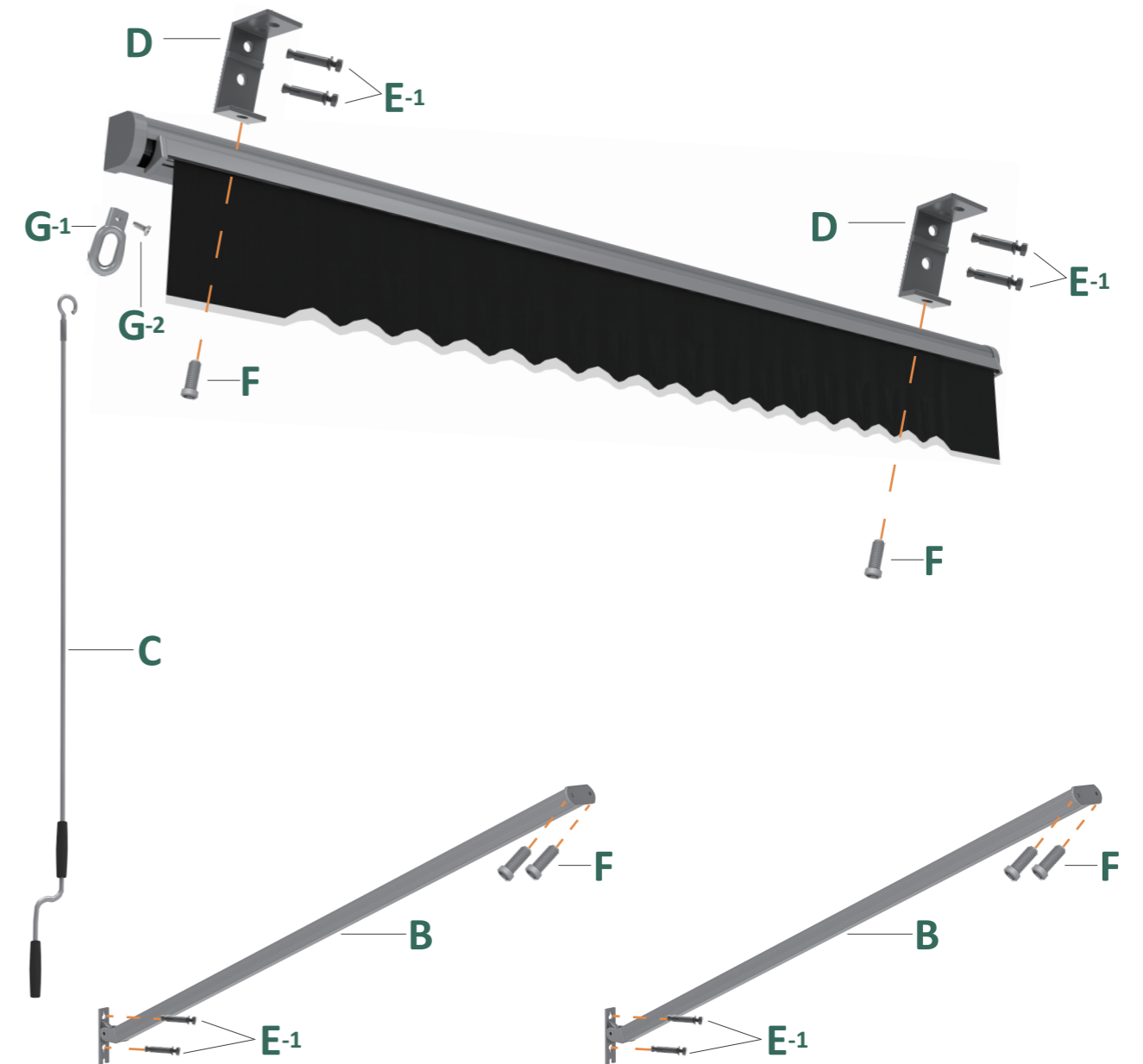

## 4. Assembly Steps

### Step1 - Install the Awning.

(1). Attach Ring (#G-1) to the awning with Bolt (#G-2).



(2). Punching Distance: It is recommended to punch the holes approximately 1/4 Length from the ends.

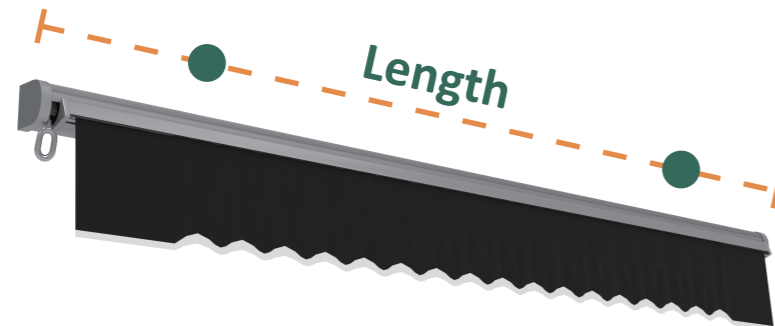

(3). When the wall bracket (#D) is mounted on the wall.  
When the wall bracket (#D) is mounted on the ceiling.

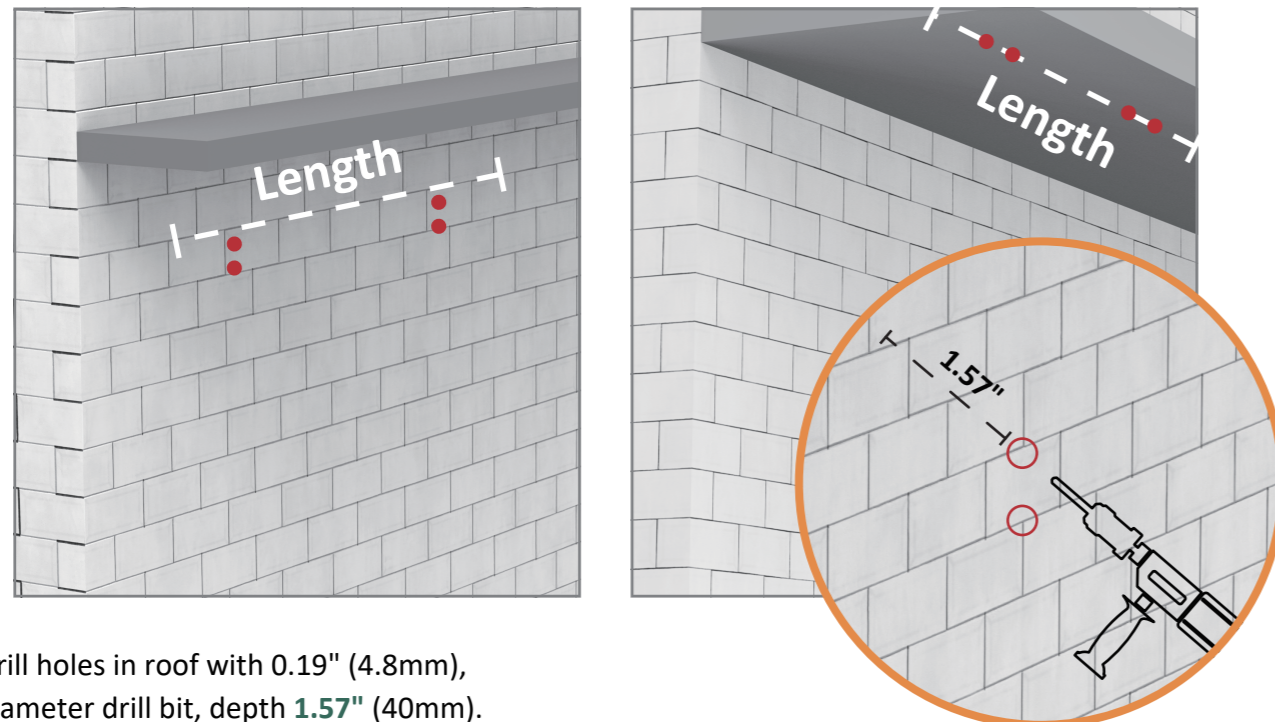

(4). Drill holes in roof with 0.19" (4.8mm), diameter drill bit, depth 1.57" (40mm).

(5). Attach the wall bracket (#D) to the wall/ ceiling through expansion bolt (#E1)/ wood screw (#E2).

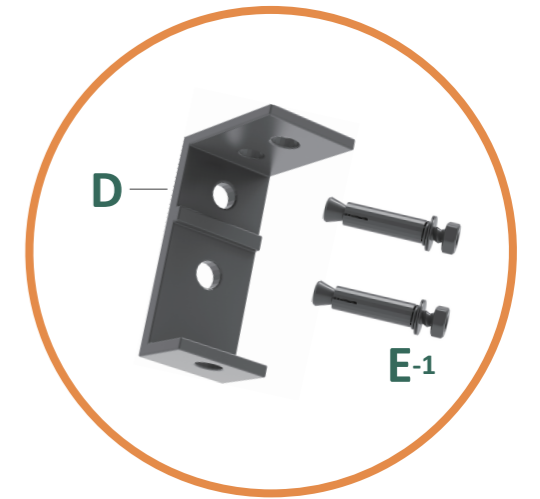

(6). Secure and lock Awning (#A) with the wall bracket (#D).  
Fastening the M6 Bolt (#F).

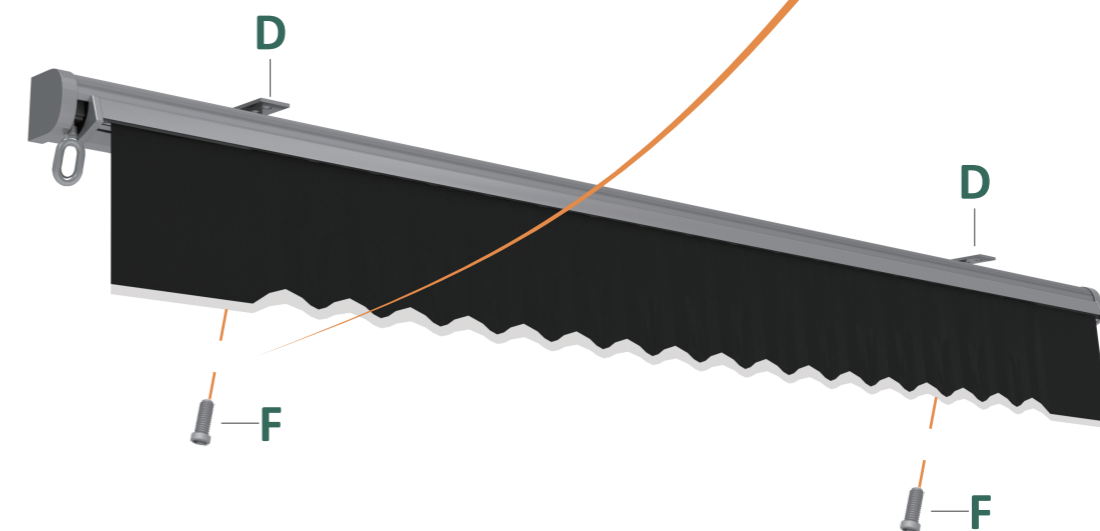
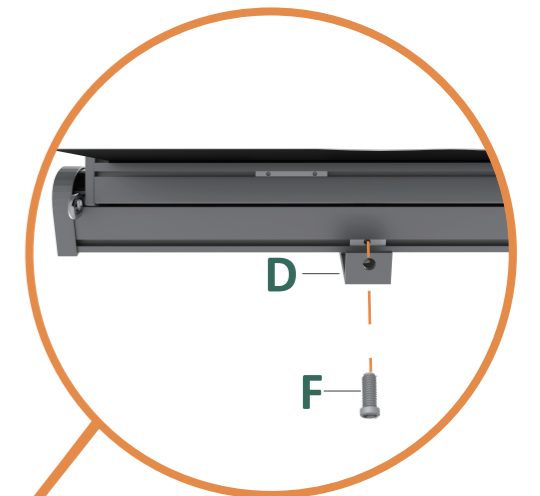

### Step2 - Install the Arms.

**ATTENTION**

Please measure the length of the arm before installation.

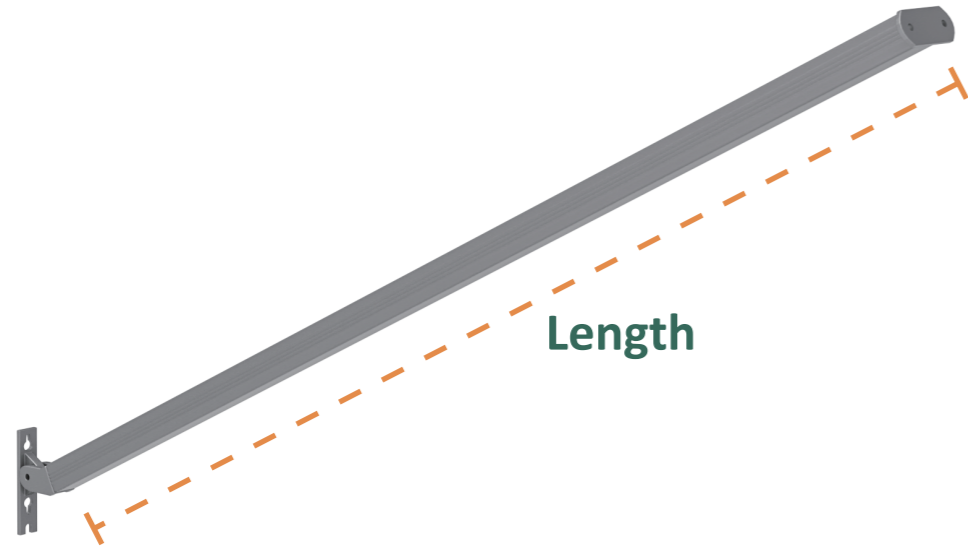

(2). Marking position: the vertical distance from the awning to the arm installation position is the length of the arm.

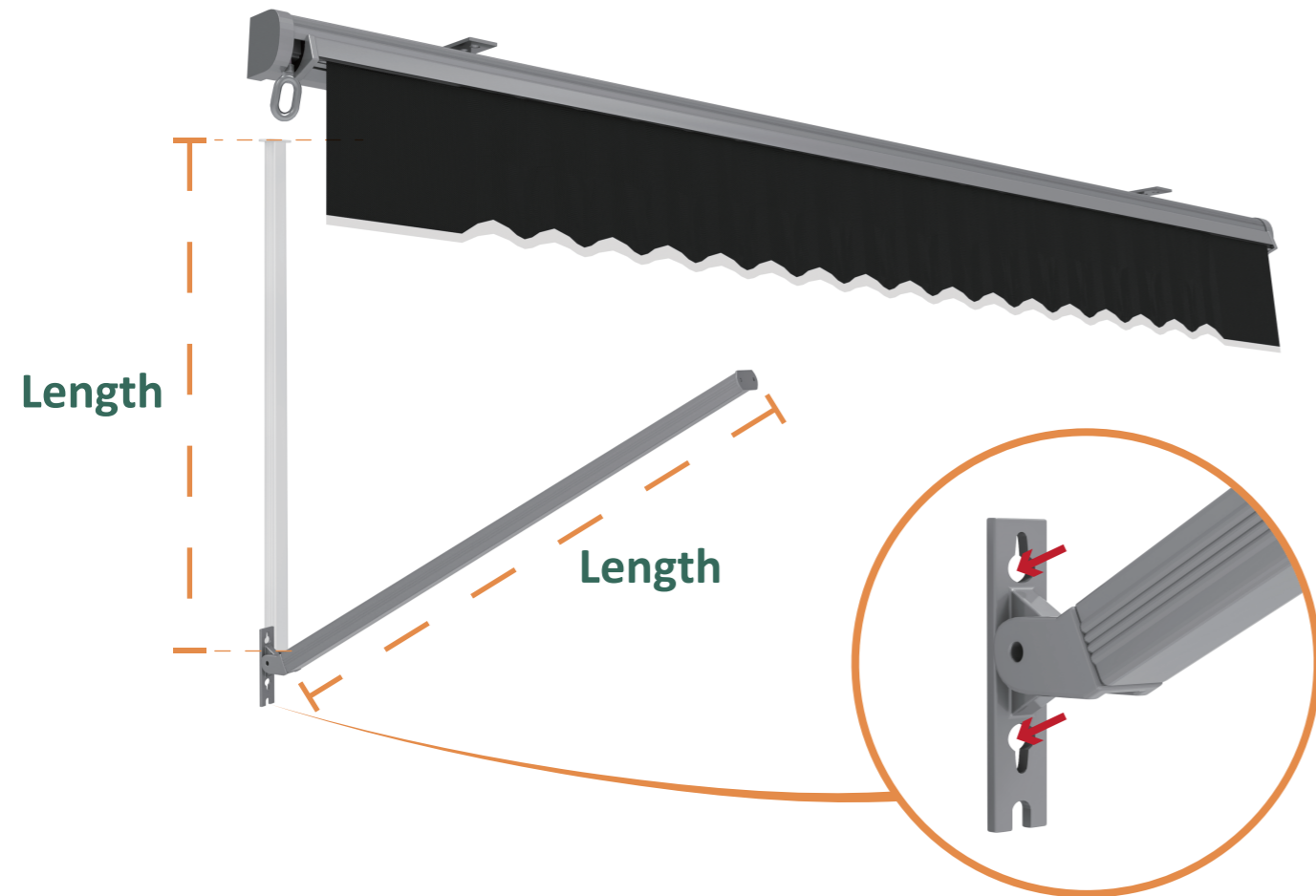

(3). Connect one end of the arm (#B) to the awning by the M6 bolt set (#F).

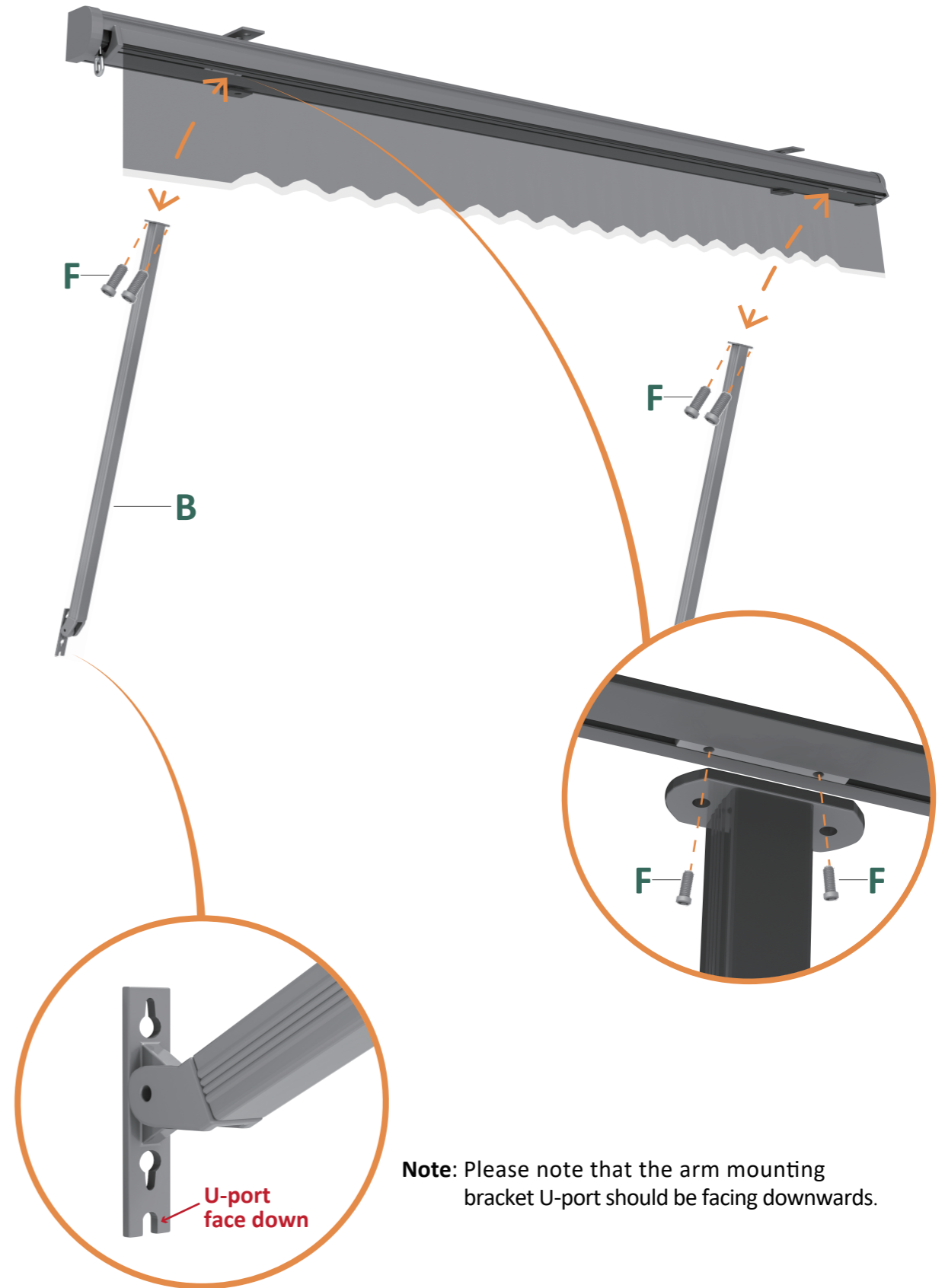

**Note:** Please note that the arm mounting bracket U-port should be facing downwards.

(4). Hang the hand crank (#C) and lower the awning.

Attach the other end of the arm with expansion bolts (#E-1) to the location previously marked on the wall.

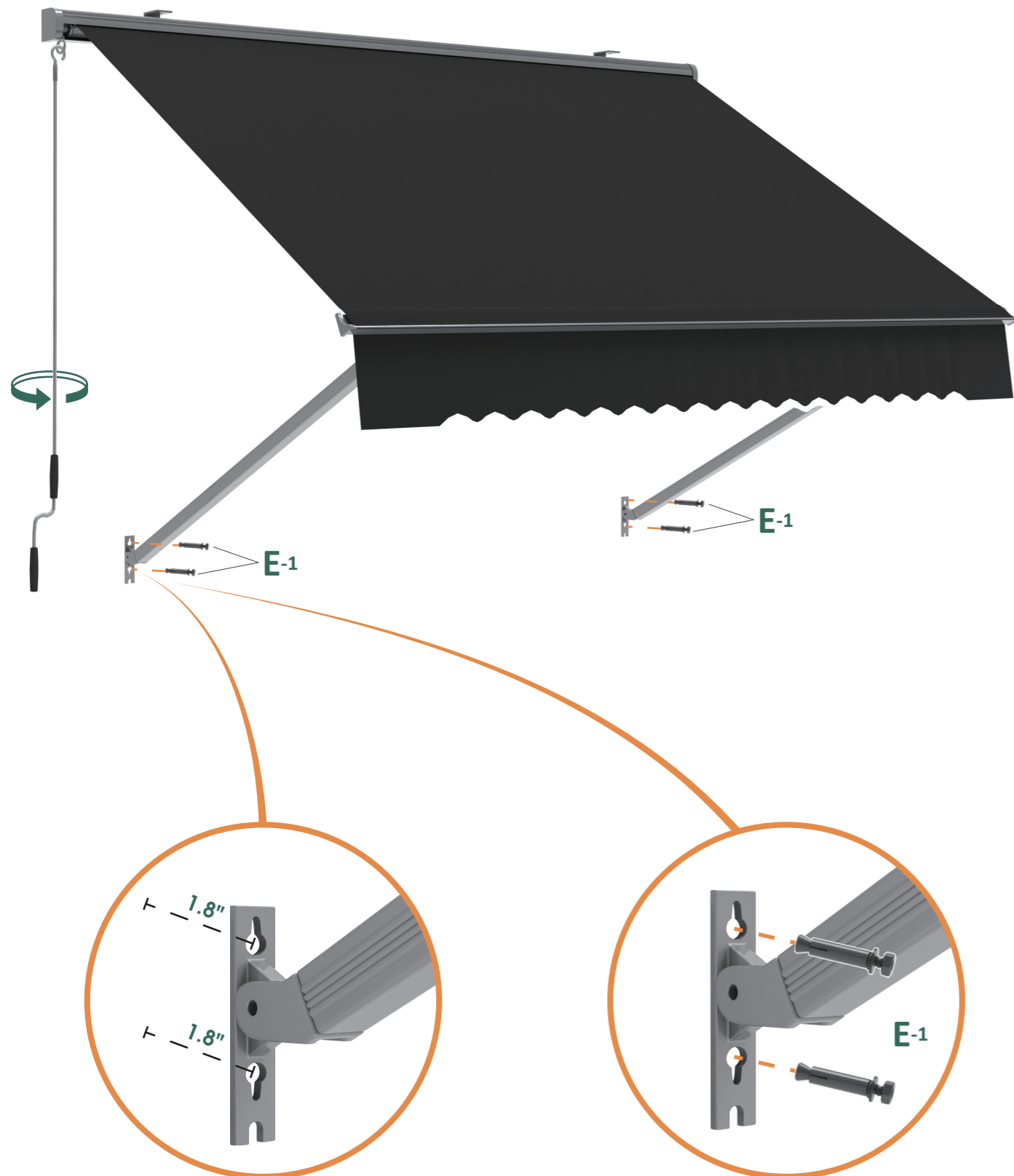

## IV. WARRANTY

### ■ Notice

- For product beyond the limited manufacturer warranty period and scope, Macrout can also provide replacement service, but a basic charge will be charged according to the circumstances.
- The warranty only applies to Macrout products and does not include any accessories or enhancements.
- Warranties are only valid in the 48 contiguous United States and are contingent upon the consumer operating the product according to the corresponding instruction manual.

<b>Awning Frame</b>	★ 1 Year
<b>Awning Fabric</b>	★ 6 Months

### CONSUMER WARRANTY LIMITATIONS AND EXCLUSIONS

All warranties begin on the date of delivery.

All warranties are to the original purchaser from Macrout ONLY.

- Macrout will replace the defective parts or send replacement product provided that the warranty parts have not been subjected to misuse, abuse or improper service by the consumer, for example, damaged wire arising in consequence of negligence or improper operation.
- Exclusions also include components with damage caused by:
  - Contamination
  - Abuse, misuse, accident, or negligence
  - Commercial use, or use other than normal
  - Improper operation, maintenance, or storage

### NOTE:

Macrout will pay standard shipping rates on all warranted parts for the first year. We can also sell you replacement part for a discount price when your product is out of warranty policy.

## V. RETURN/ REPLACEMENT POLICY

**■ Notice**

**Why don't we recommend returning the item by yourself?**

- Huge cost- UPS/FedEx oversize fee.
- Need you to take the box to UPS/FedEx facility.

### Return/ Replacement Policy

**Macrout**

You have 30 days from the date of purchase to return any item purchased from our store. Please securely pack the item in its original packaging, including any accessories or manuals that came with the product. To initiate a return, please contact our customer service team at sales@macrout.com/ (302) 268-8644 for any help.

**Return Conditions**



We accept the return of items that are in new, unused condition, with original tags attached and all original packaging and other components included. Refunds will be issued in the original form of payment for the price of the item, including taxes.

**NOTE:**

- Please keep the original packaging in case the product needs to be returned. If the original packaging is not available, the newly found packaging needs to meet the following size standard:  
UPS/FedEx packaging size standard: ( width+ height ) \* 2+ length < 128 inch.
- Please disassemble the product before you return it, otherwise there will be a huge cost as oversized and it could even exceed your order amount.
- Please do not purchase return label for a damaged/defective product by yourself.
- If you have any problem to return the product, please contact us immediately, we will do our best to help you with a reasonable solution.

## VI. Macrout Customer Support

If for any reason, we have fallen short of your expectations, or if you have any questions and suggests, please refer to the following contact information, we will do our best to work with you to make sure you are entirely satisfied.

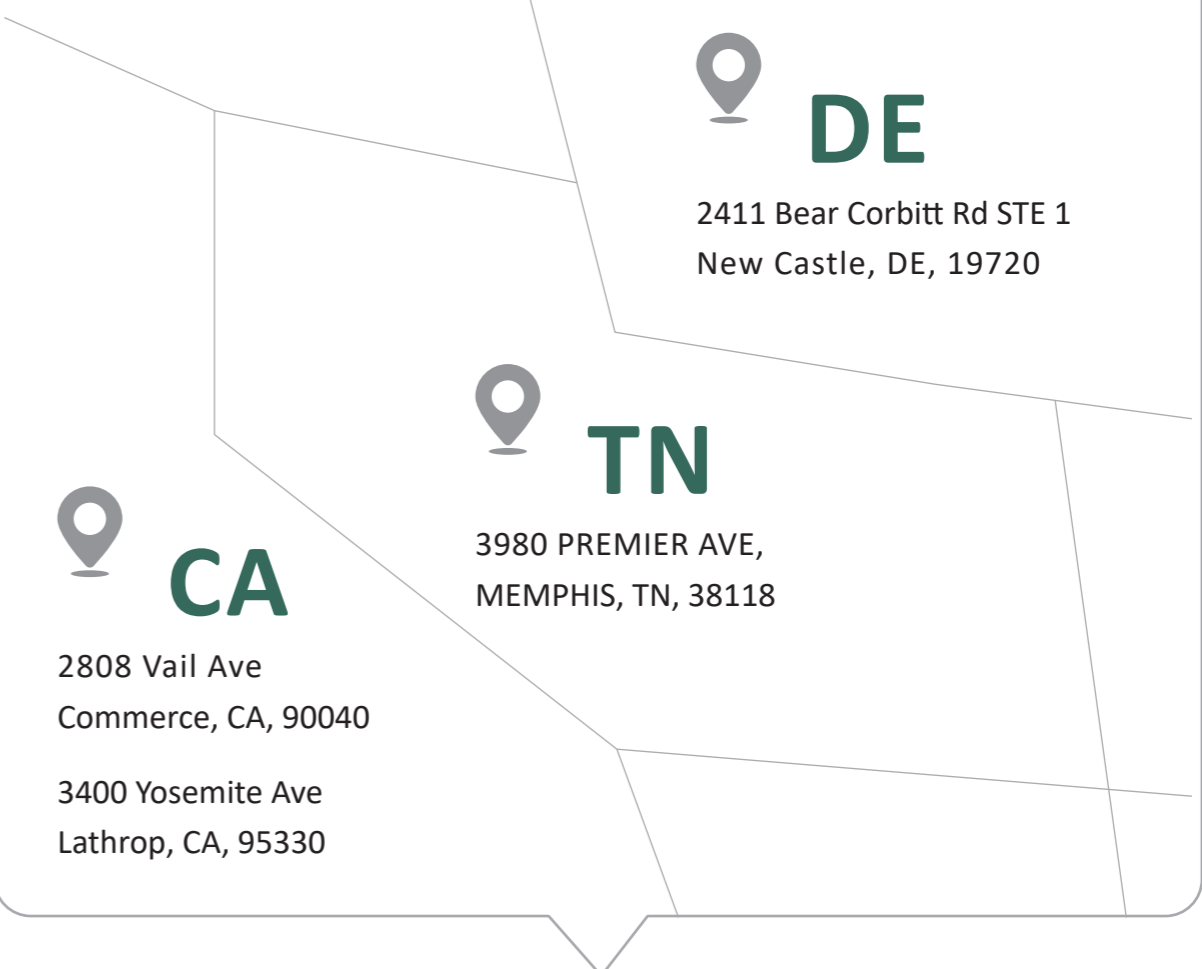
	<p>sales@macrout.com (Respond within 24 hours)</p>
	<p><b>(302) 268-8644</b> 8:00 a.m. - 4:00 p.m. (Monday - Friday) TIME ZONE: PST</p>
 <div data-bbox="1715 1465 2012 1808"> <p><b>CA</b></p> <p>2808 Vail Ave Commerce, CA, 90040</p> <p>3400 Yosemite Ave Lathrop, CA, 95330</p> </div> <div data-bbox="2101 1352 2377 1577"> <p><b>TN</b></p> <p>3980 PREMIER AVE, MEMPHIS, TN, 38118</p> </div> <div data-bbox="2309 1045 2653 1270"> <p><b>DE</b></p> <p>2411 Bear Corbitt Rd STE 1 New Castle, DE, 19720</p> </div>	