

NOTES:

1. TO INSPECT ASSEMBLY, FOLLOW FIRST ARTICLE AND IN PROCESS INSPECTION SHEET.

**BILL OF MATERIAL (CURRENT LEVEL)**

ITEM	PT/ASSY	DESCRIPTION	TYPE	QTY.
1	199X	GRAB BAR MOUNTING HARDWARE PACK	ASSEMBLY	2
2	1995	MOUNTING FLANGE	PART	2
3	0372	DECORATIVE RING	PART	2
4	5084	GRAB BAR AND ADAPTER ASSY	ASSEMBLY	1

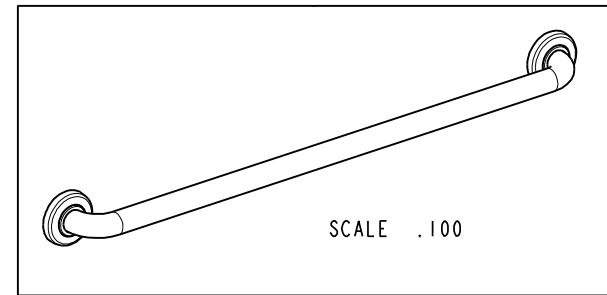
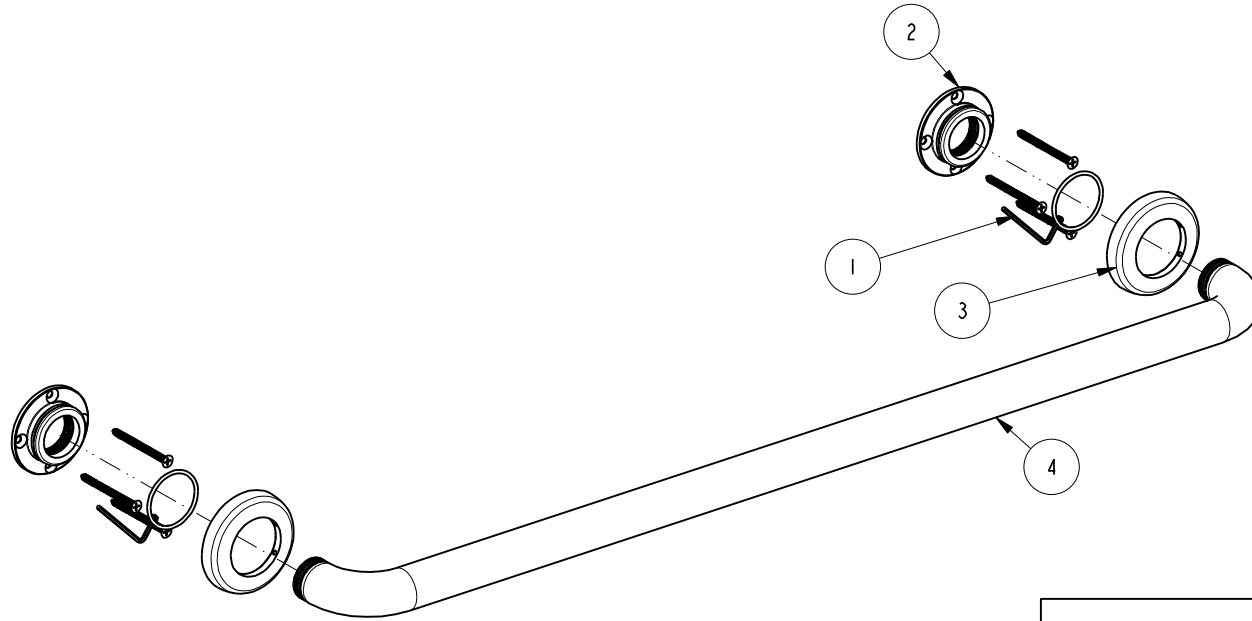

ZONE	REV	DESCRIPTION	DATE	APPROVED
-	D	EN-4300i	06/22/21	R.S.
-	C	EN-4143	03/20/20	J.M.
-	B	EN-2635	10/29/13	N.S.
-	A	EN-1009	11/20/09	J.M.

COPYRIGHT 2005 BRASSTECH, INC. THESE DRAWINGS AND THE DESIGNS DEPICTED HEREIN ARE THE PROPRIETARY PROPERTY OF BRASSTECH. ANY USE OR REPRODUCTION IS SUBJECT TO THE EXPRESS APPROVAL OF BRASSTECH. UNAUTHORIZED USE IS STRICTLY PROHIBITED. ALL RIGHTS RESERVED.

TESTING	-	-	-
ASSEMBLY	-	-	-
PLATING	-	-	-
POLISHING	-	NEXT ASSY	USED ON
MACHINING	-	APPLICATION	
TOOLING FIXTURE #	REMOVE ALL BURRS AND SHARP EDGES		

UNITS ARE: INCHES [MM]		
TOLERANCES ARE:		
FRACTIONS	DECIMALS	ANGLES
±1/16"	.X ±.1 [2.5]	±1°
	.XX ±.06 [1.5]	
X.XXX DENOTES CRITICAL DIMS.		
ALL THREADS ARE CRITICAL		
DRAWN	JINSON	06/22/21
CHECKED	R.S.	06/22/21
APPROVED	R.S.	06/22/21

<b>BRASSTECH</b>		2001 CARNEGIE AVE. SANTA ANA, CA 92705 (949) 417-5207	
INCORPORATED			
32" CURVED GRAB BAR ASSEMBLY			
DWG NO.	0364	REV	D
SCALE	.312	REF.	-
SHEET 1		OF 2	

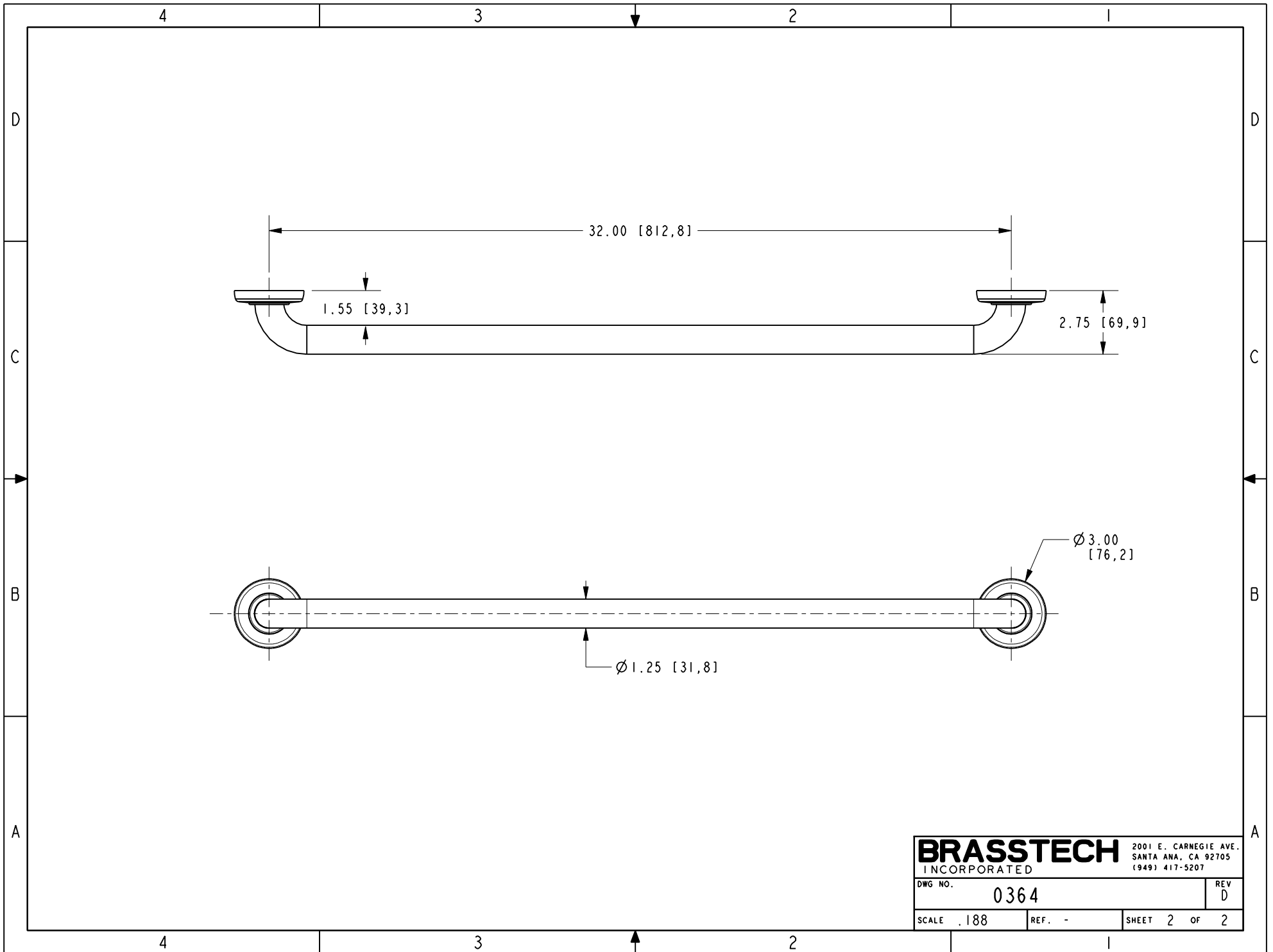

<b>BRASSTECH</b>		2001 E. CARNEGIE AVE. SANTA ANA, CA 92705 (949) 417-5207	
DWG NO.	0364	REV	D
SCALE	.188	REF.	-
		SHEET	2 OF 2