

Step 1

Parts Required: Panel A1, Panel A2, Panel B
N1(4PCS), N2(4PCS), N3(4PCS)

- Lay panel A1 & A2 down with the Front sticker facing up
- Attach panel B to A1 & A2 according to diagram
- Hand fasten bolts, do not tighten

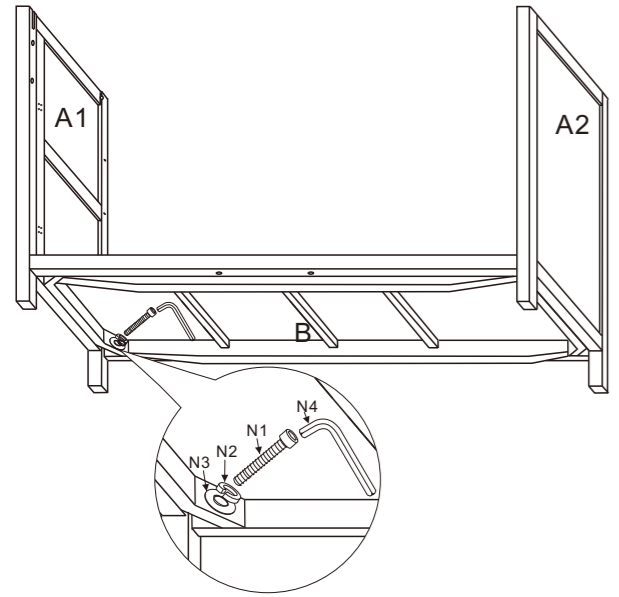

Step 2

Parts Required: Panel D1, Panel D2, Panel D3 (2pcs) ,
N1(4PCS)

- Attach panel D1, D2, D3 according to diagram
- Hand fasten bolts, do not tighten

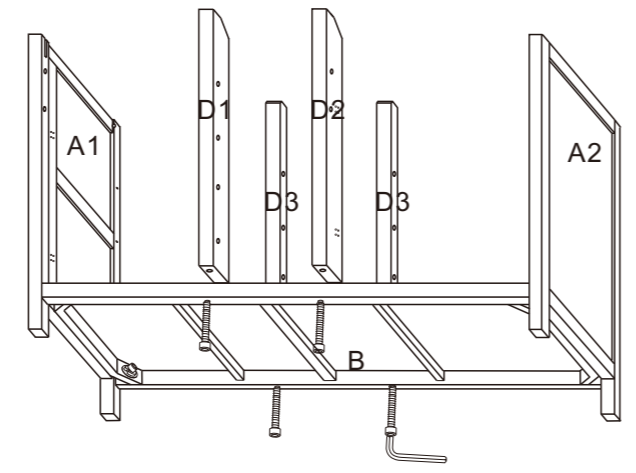

Step 5

Parts Required: Panel F,
N1 (8pcs), N2 (4pcs), N3 (4pcs)

- Place panel F as shown on diagram. Watch for "Front" and "UP" indicators for proper placement
- Hand fasten the side bolts, starting with both sides. Do not tighten

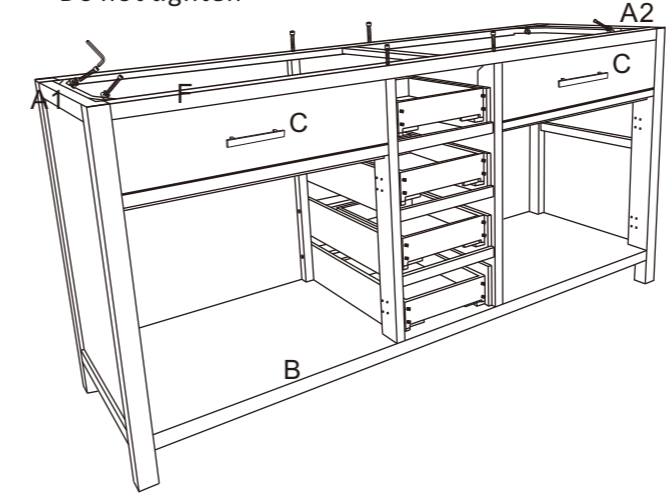

- Notice that tightening the bolts will adjust the positioning of panel F. Work all 4 corners until the panel sits straight
- Once Panel F is adjusted correctly, tighten the other N1 bolts underneath the cabinet. Adjust carefully and do not overtighten

Step 6

Parts Required: Panel I (4pcs),
N5.1 (4pcs), N11 (8pcs)

- Attach N5.1 to panel I using N11 (2 per handle). Tighten

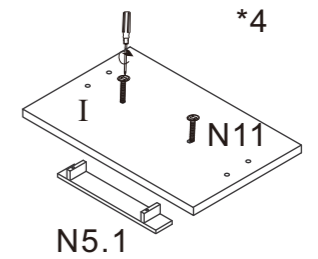

Step 3

Parts Required: Panel J1, Panel J2(3pcs) ,
N8(16PCS)

- Stand up the cabinet, attach panel J1 & J2 according to diagram. Watch for "Front" indicators for proper placement
- Secure with N8 bolts. Do not overtighten

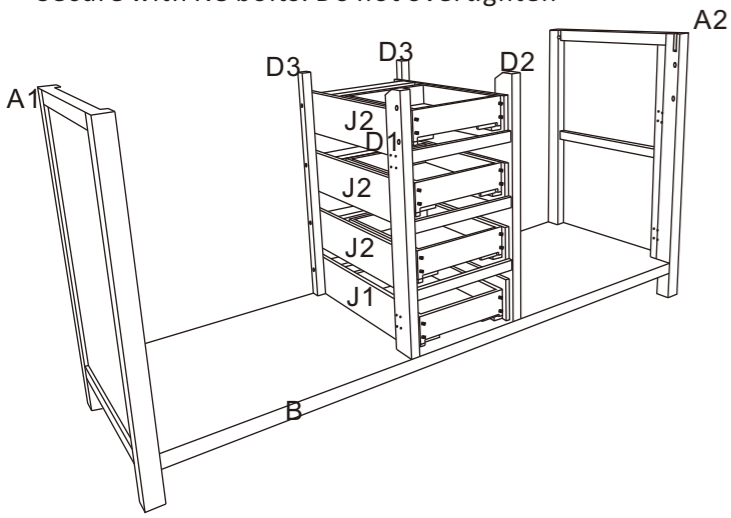

Step 4

Parts Required: Panel C (2pcs)
N5.1(2PCS), N11(4PCS),

- Attach N5.1 to panel C using N11 (2 per handle). Tighten
- Attach panel C according to diagram

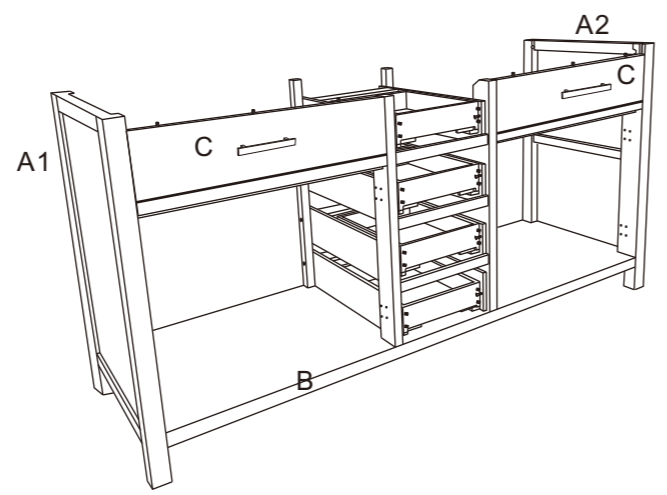

Step 7

Parts Required: N9 (16pcs)

- Attach Panel I to Panel J1 or J2, Watch for "UP" indicator
- Secure with N9

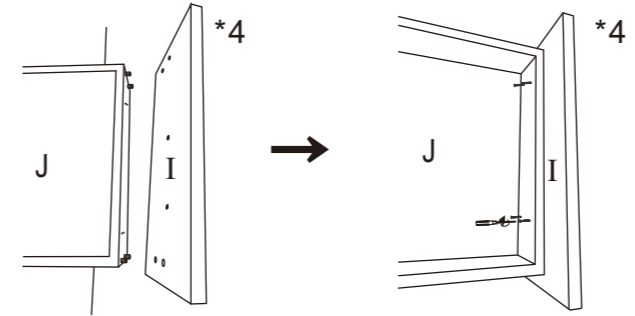

Step 8

- If any of the drawers are not sitting correctly, they can be adjusted by either repositioning the drawer glides or adjusting the height adjustment poles as shown in the diagram

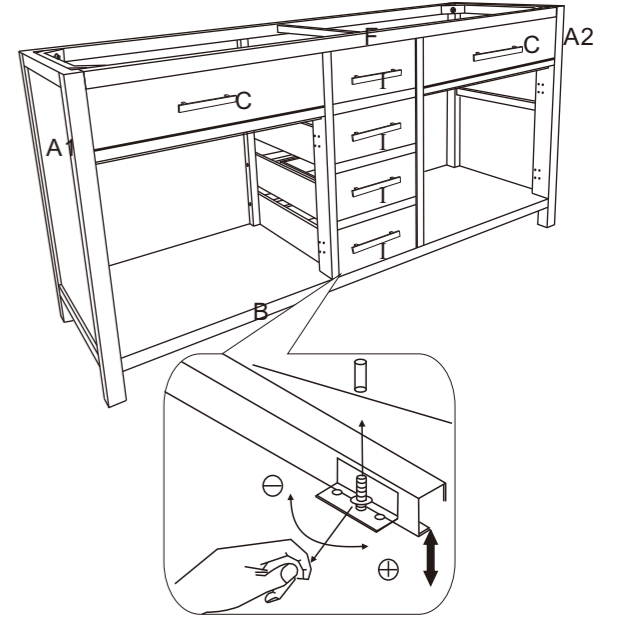

Step 9

Parts Required: Panel H1(2pcs) ,Panel H2(2pcs)
N5.2 (4pcs), N6 (8pcs), N11 (8pcs), N10 (16pcs)

- Attach N6 hinges to doors as shown in diagram. 2 N10 screws per hinge
- Attach N5.2 handles to doors using N11 bolts

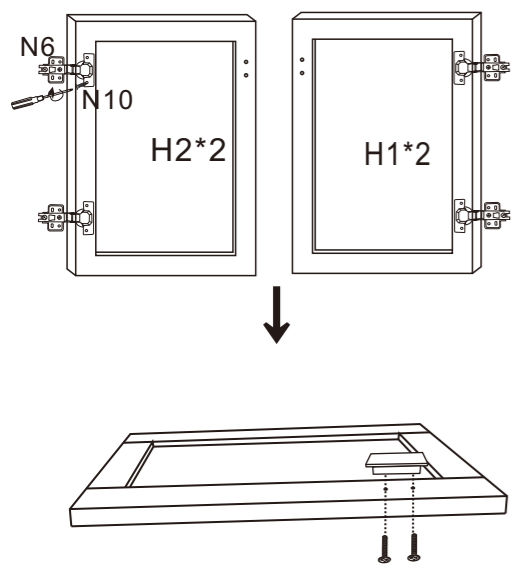

Step 10

Parts Required: N10 (8pcs)

- Locate the indentations in the cabinet where the hinges should attach to. Use these indentations to drill and secure the door hinges by the large holes found on the hinges using N10 screws (1 N10 per hinge)
- Do not overtighten the screws to allow adjustments found on the next step

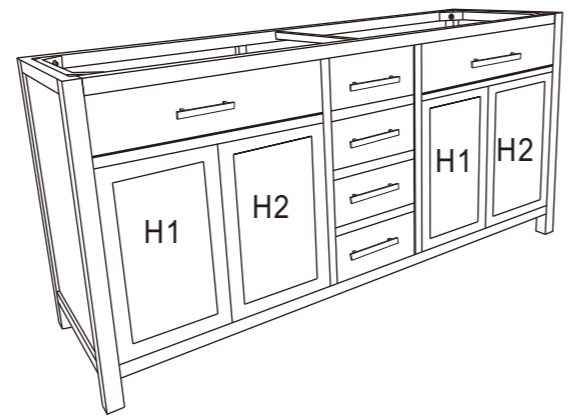

Assembly Instructions



Some important notes before beginning assembly:

- Count all parts and hardware to make sure that there are no pieces missing. If there are pieces missing or damaged, please email us to request the part to be sent to you.
- If a power drill or screwdriver is used, set the tool on low power setting. Reclaimed woods are generally a bit delicate, and using a power tool with too much power or speed may damage the wood.
- When assembling the cabinet, do not tighten the bolts until all cabinet pieces are put together. Keeping the bolts loose will greatly help with adjustments and preventing damage. Tighten the bolts after every piece is in place.
- Each cabinet panel will have a sticker to indicate which side is the front. Follow these stickers to make sure the pieces are not assembled backwards.

Step 11

Parts Required: N10 (24pcs)

- The doors can be adjusted left/right or in/out by adjusting the screw on each hinge as shown on the diagram
- Once adjustments are done, use N10 screws (3 per hinge) to properly secure the hinges to the cabinet. Tighten all screws

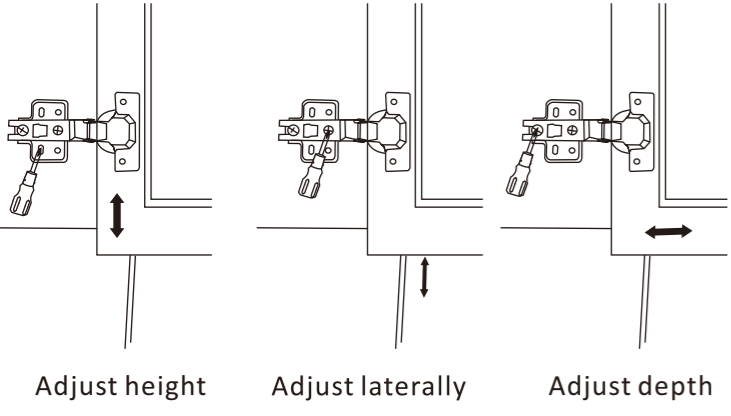

Hardware List

N	Screwdriver	1pc	
N1	Long Bolt	16pcs	
N2	Tension Washer	8pcs	
N3	Washer	8pcs	
N4	Allen Wrench	1pc	
N5.1	Drawer Pull	6pcs	
N5.2	Door Pull	4pcs	
N6	Door Hinge	8pcs	
N8	Short Bolt	16pcs	
N9	Long Wood Screw	16pcs	
N10	Short Wood Screw	48pcs	
N11	Hardware Screw	20pcs	

Parts List

