

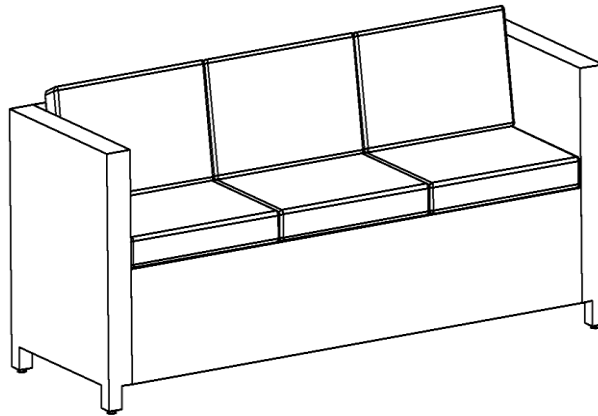



Assembly Instructions

Caution: You must read this before you proceed



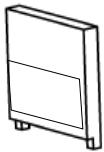
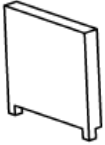
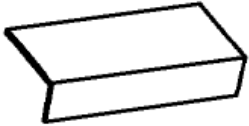
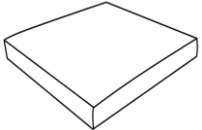

Three-seater Sofa



Parts List

Label	Picture	Description	QTY
A		Backrest	1
B		Right Armrest	1
C		Left Armrest	1
D		Seat	1
E		Seat Cushion	3
F		Back Cushion	3

Hardware

Label	Picture	Description	QTY
①		Bolt Cap	16
②		Bolt (M6*40mm)	16
③		Washer	16
④		Spring Washer (Ø16*2mm)	16
⑤		Allen Key	1

Assembly Preparation

Before Beginning Assembly:

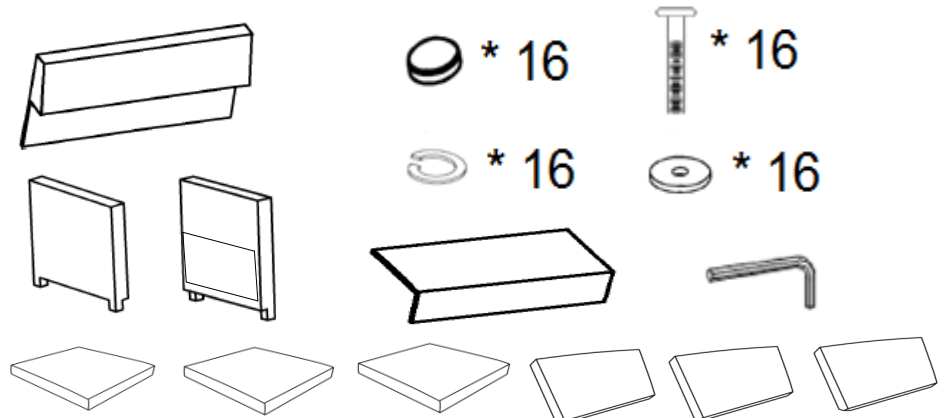

- Read instructions, cover to cover-



- Have 2 adults on hand for assembly-



- Do not assemble on flooring or carpet-



- Assemble on a clean non-marring surface (packing foam)-



- Save all packaging until finished-

Assembly Steps

Overview

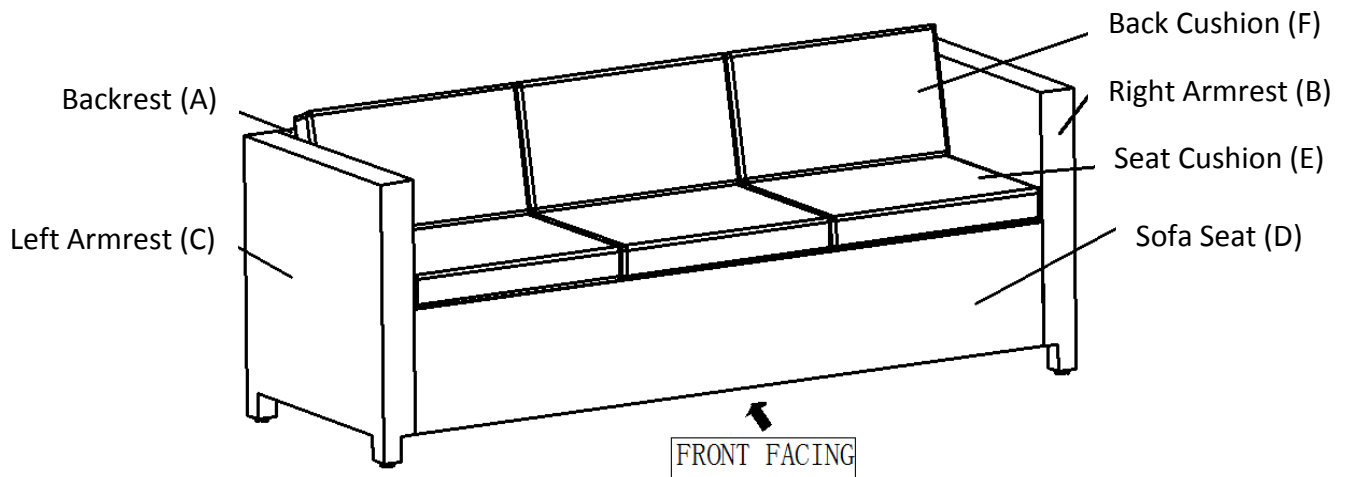

This Three-seater Sofa has multiple parts and may require up to 30 minutes to assemble. To give you an overview of the Three-seater Sofa parts, the above picture is to help you put the various parts into perspective. Please read through the instructions below to familiarise yourself with the parts and steps before assembly.

Step 1

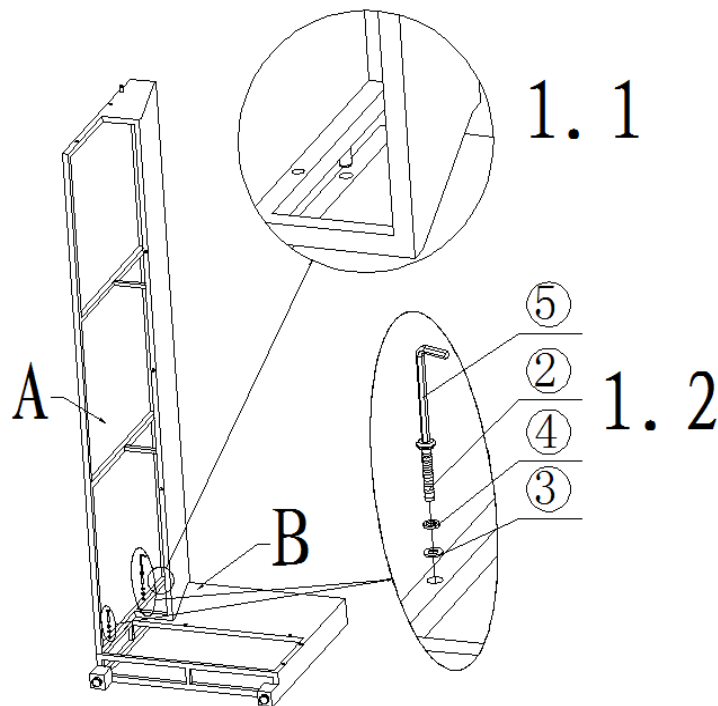

NOTE: It is recommended that you have a partner to assist during the entire assembly process.

Open the carton and place all the parts onto a clean and soft surface.

Place the Right Armrest(B) with its inner side, facing skywards.

Step 1.1 Insert the positioning dowels on Backrest(A) into Right Armrest(B) as pictured above.

Step 1.2 Attach Backrest(A) to Right Armrest(B) using Bolts(2), Spring Washers(4), and Washers(3) with Allen Key(5).

Do not fully tighten the Bolts.

There may be some PE wicker that may have shifted and covered the Bolt points. To ease assembly, guide and slide the PE wicker away from the mounting positions. DO NOT CUT AWAY any PE WICKER as this would cause the wicker to unravel!

Step 2

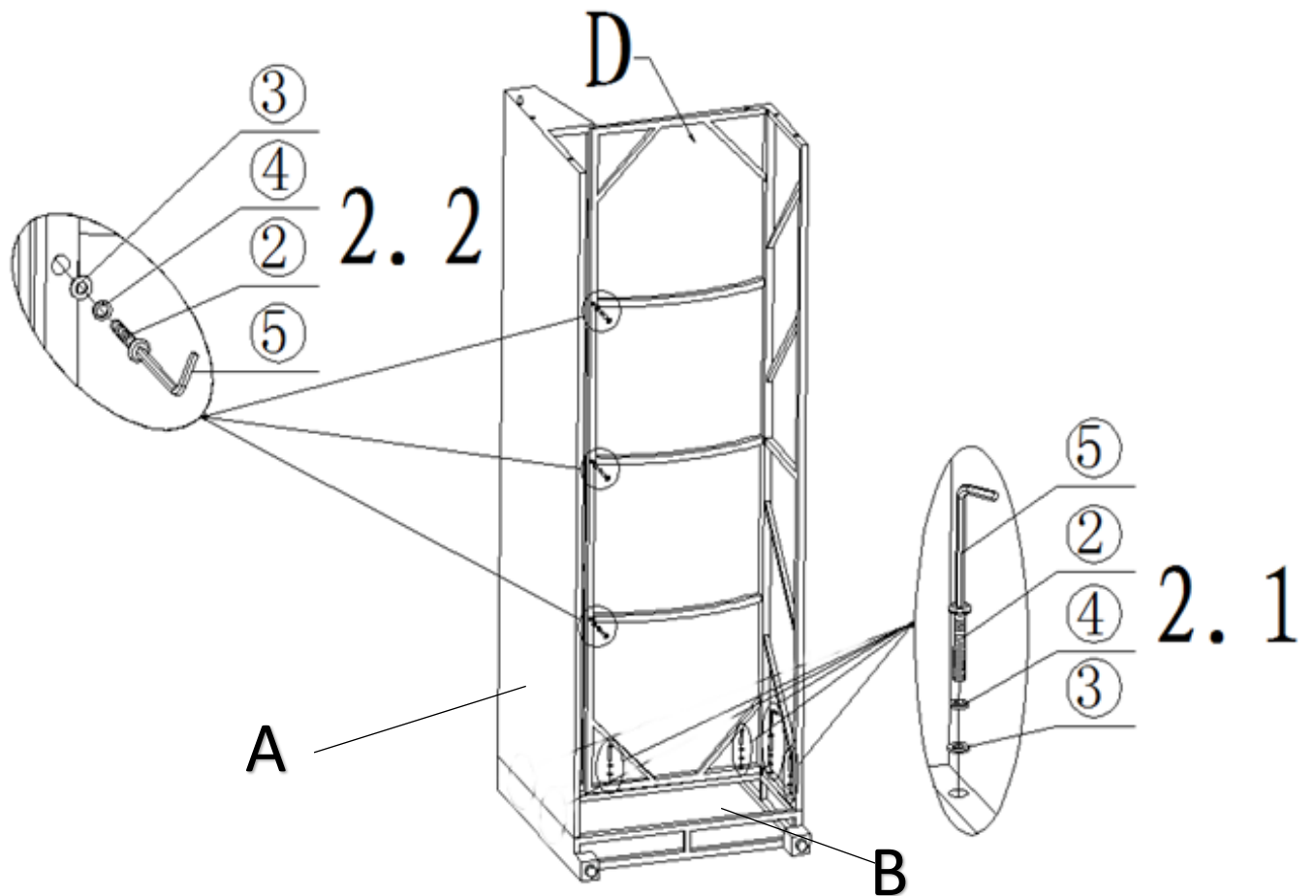

Align the Seat(D) to Right Armrest(B) and Backrest(A).

Step 2.1 Attach Seat(D) to Right Armrest(B) using Bolts(②), Spring Washers(④), and Washers(③) with Allen Key(⑤). **total with 4pcs Bolts(②).**

Step 2.2 Attach Seat(D) to Backrest(A) using Bolts(②), Spring Washers(④), and Washers(③) with Allen Key(⑤). **total with 3pcs Bolts(②).**

Do not fully tighten the Bolts.

There may be some PE wicker that may have shifted and covered the Bolt points. To ease assembly, guide and slide the PE wicker away from the mounting positions. DO NOT CUT AWAY any PE WICKER as this would cause the wicker to unravel!

Step 3

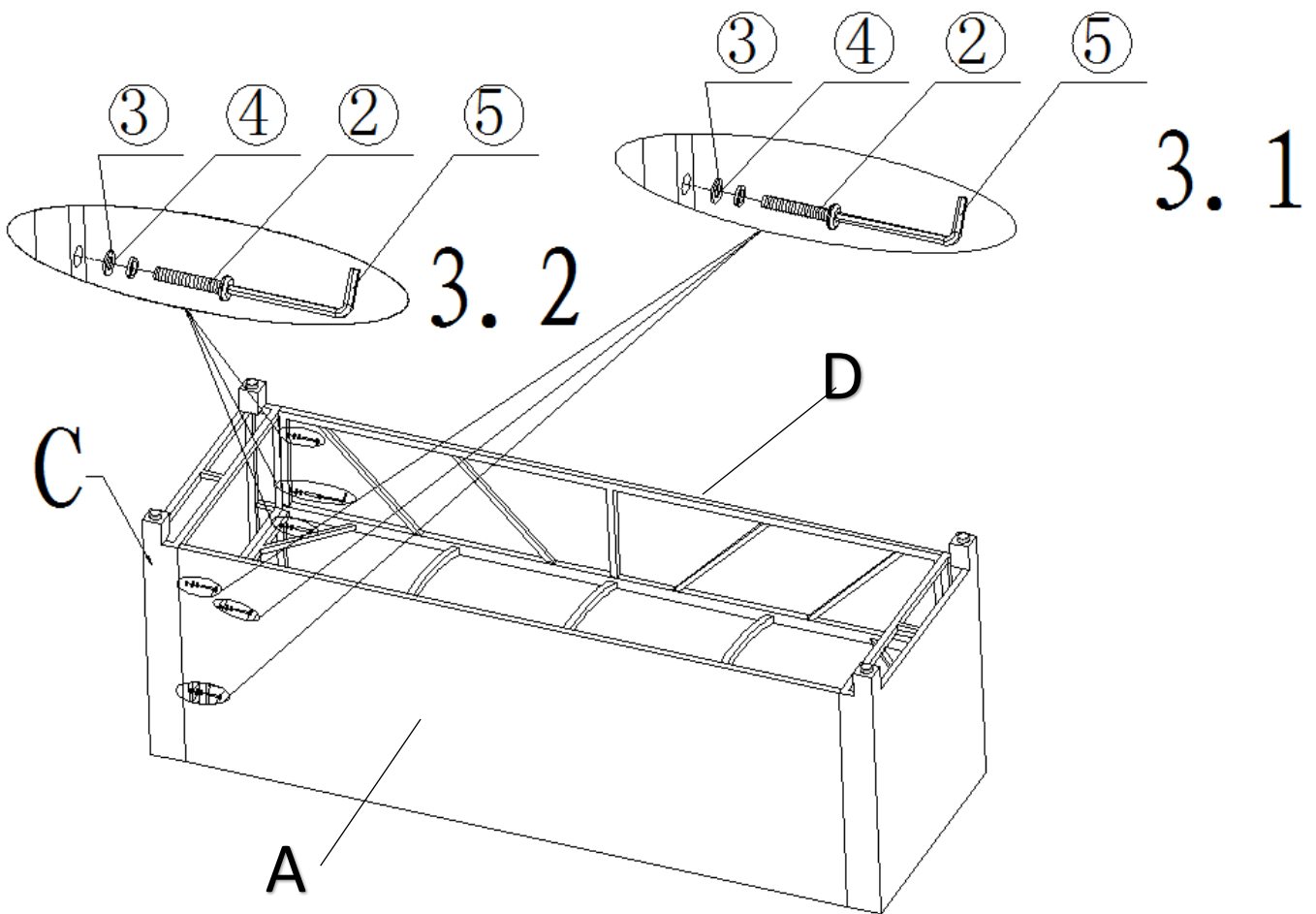

Insert the positioning dowels on Backrest(A) into Left Armrest(C).

Step 3.1 Attach Backrest(A) to Left Armrest(C) using Bolts(②), Spring Washers(④), and Washers(③) with Allen Key(⑤).

Step 3.2 Attach Seat(D) to Left Armrest(C) using Bolts(②), Spring Washers(④), and Washers(③) with Allen Key(⑤).

Do not fully tighten the Bolts.

There may be some PE wicker that may have **shifted and covered the Bolt points**. To ease assembly, guide and slide the PE wicker away from the mounting positions. **DO NOT CUT AWAY** any PE WICKER as this would cause the wicker to unravel!

Step 4

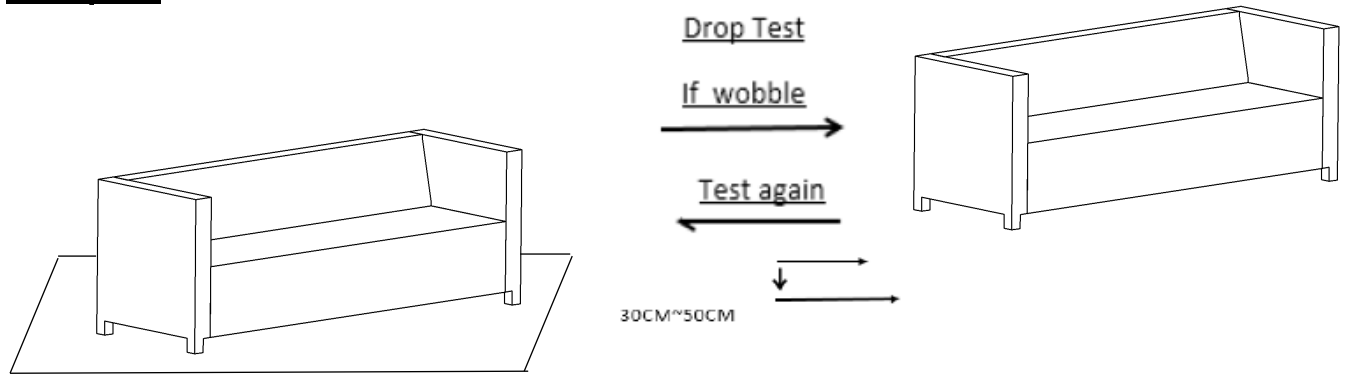

With the help of your adult partner, place the Sofa on a level surface to check for wobbles.

If it wobbles, lift the Sofa some 30cm to 50cm high from the ground.

Keep your feet and toes well away from the drop zone.

Drop the Sofa freely and vertically with all four legs, hitting the ground, all at the same time.

This Drop Test will help to ensure that all the Bolts and gaps reach full alignment status.

Test again for evenness on a level surface.

If no wobbles are found, slowly and steadily, place the Sofa facedown.

Then, proceed to tighten all Bolts at all joints in a sequential manner.

When tightening the Bolts, tighten sequentially.

DO NOT tighten any Bolt fully and then move on towards the next one.

This could cause the frame to warp. If there are still wobbles, loosen the Bolts and execute the same drop test.

If the Sofa is not stable, it could lead to damage to the product.

Step 5

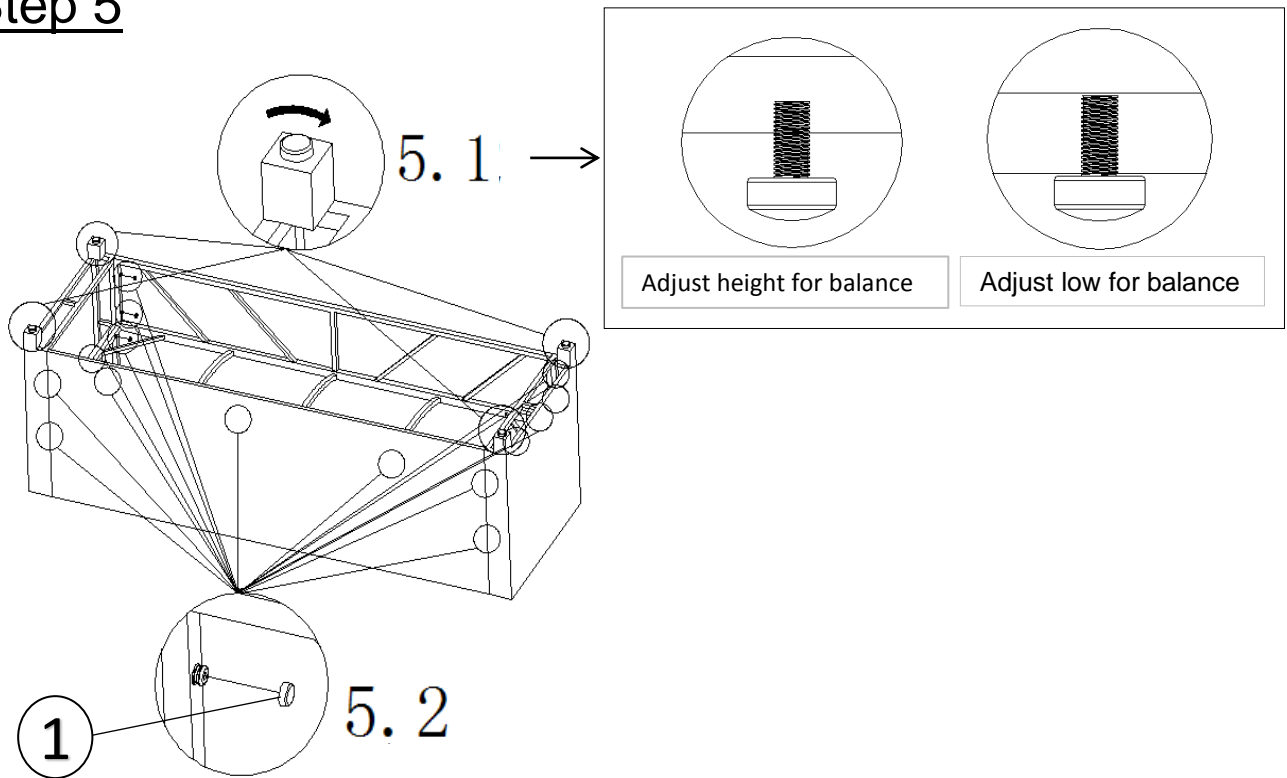





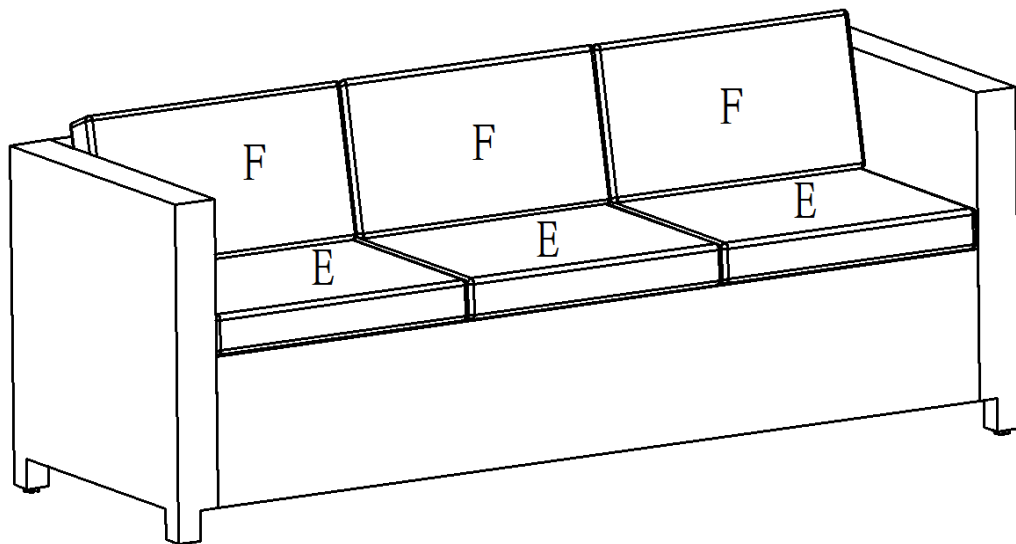















Step 5.1 With the help of your adult partner, stand the Sofa up.
Adjust the Pre-attached Levellers until the Chair is level with the ground.
Step 5.2 Then cover all the Bolts with the Bolt Caps(①).

Step 6



Turn the SOFA right side up.
Place the Seat Cushions(E) and Back Cushions(F) onto the Three-seater Sofa.
Your Three-seater Sofa is ready for use.
This Three-seater Sofa can only be used on a flat, level surface.

Care & Maintenance

-   Do not put hot items directly on furniture surface.
 -   Do not clean furniture with harsh cleansers or polish.
 -   To obtain the longest lifespan of your outdoor products, minimizing exposure to direct sunlight is recommended.
 -   Children should not climb or jump on the furniture.
 -   Do not write on furniture without a padded barrier to protect the surface.
 -   To obtain the longest lifespan of your outdoor products, avoid extended and lengthy exposure to rain, snow, and direct sunshine. Whenever possible cover the product and /or place under patio or awnings.
 -   Not for commercial use. For residential use only .
 -   Stains may be removed with mild soap solution and damp cloth.
 -   Keep away from sources of ignition.
-
-   Dust and pick-up spills using a clean, non-colored, lint-free cloth .

Questions & Answers about Proposition 65

• What is Proposition 65?

Proposition 65 requires businesses to provide warnings to Californians about significant exposures to chemicals that cause cancer, birth defects or other reproductive harm. These chemicals can be in the products that Californians purchase, in their homes or workplaces, or that are released into the environment. By requiring that this information be provided, Proposition 65 enables Californians to make informed decisions about their exposures to these chemicals.

Proposition 65 also prohibits California businesses from knowingly discharging significant amounts of listed chemicals into sources of drinking water.

Proposition 65 requires California to publish a list of chemicals known to cause cancer, birth defects or other reproductive harm. This list, which must be updated at least once a year, has grown to include approximately 900 chemicals since it was first published in 1987.

• What types of chemicals are on the Proposition 65 list?

The list contains a wide range of naturally occurring and synthetic chemicals that include additives or ingredients in pesticides, common household products, food, drugs, dyes, or solvents. Listed chemicals may also be used in manufacturing and construction, or they may be byproducts of chemical processes, such as motor vehicle exhaust.

• What does a warning mean?

If a warning is placed on a product label or posted or distributed at a workplace, a business, or in rental housing, the business issuing the warning is aware or believes that it is exposing individuals to one or more listed chemicals.

By law, a warning must be given for listed chemicals unless the exposure is low enough to pose no significant risk of cancer or is significantly below levels observed to cause birth defects or other reproductive harm.

• Where can I get more information on Proposition 65?

If you have specific questions on the administration or implementation of Proposition 65, you can contact OEHHA's Proposition 65 program at P65.Questions@oehha.ca.gov, or by phone at (916) 445-6900.