

ASSEMBLY INSTRUCTION

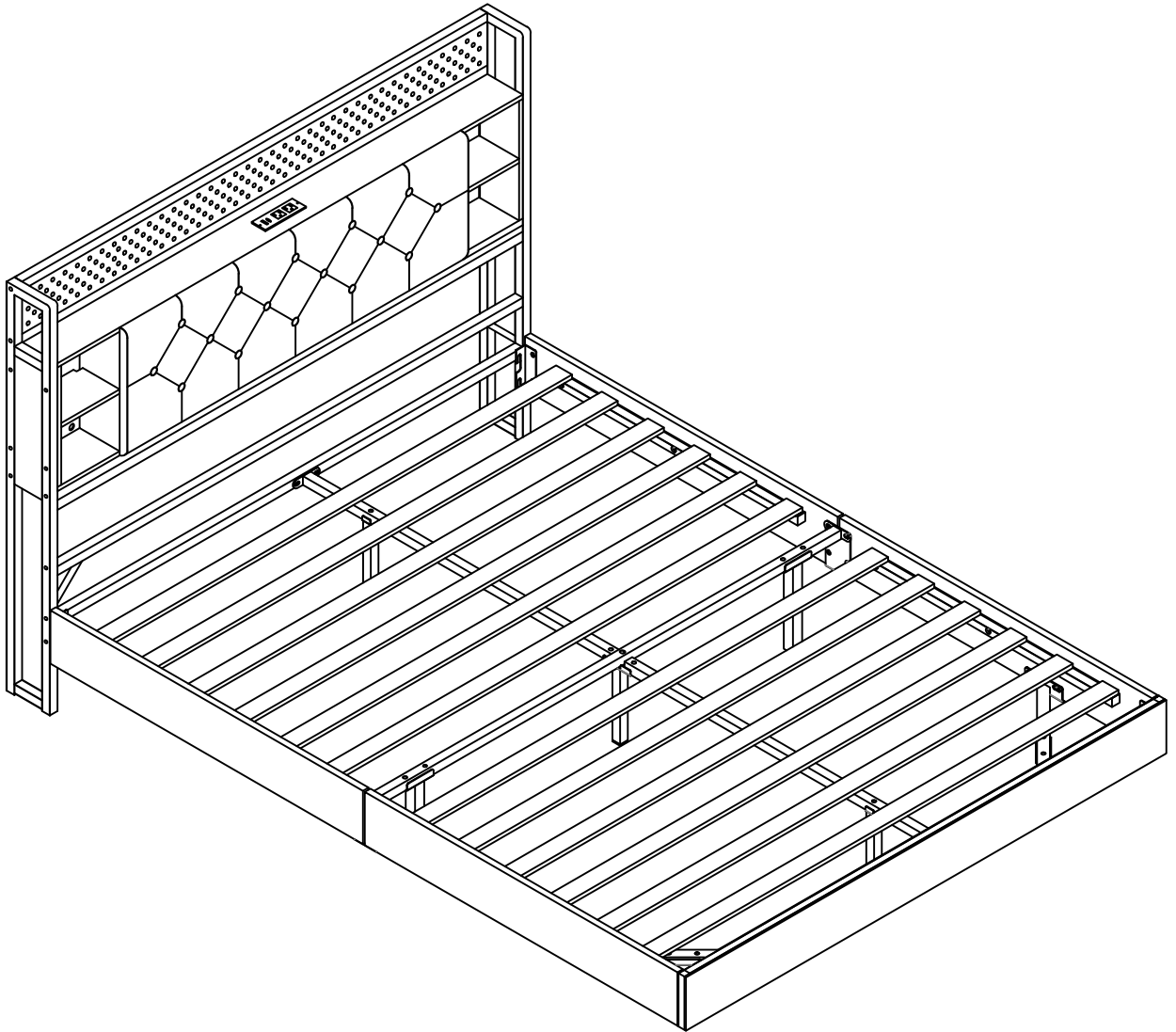

Note:

- 1. Should be assembled on flat ground to keep balance.**
- 2. Before completing the installation, do not tighten the screws.**



Assembly Instruction

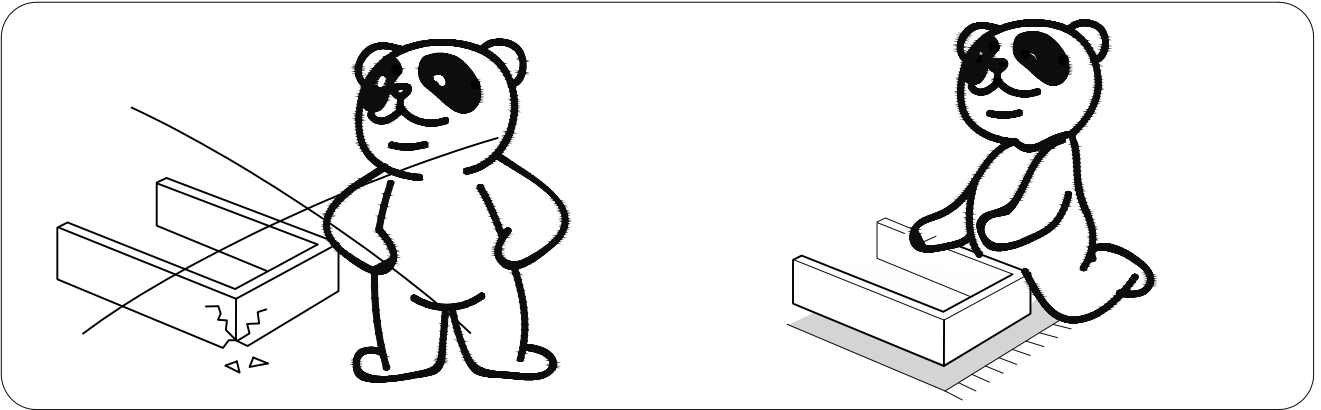
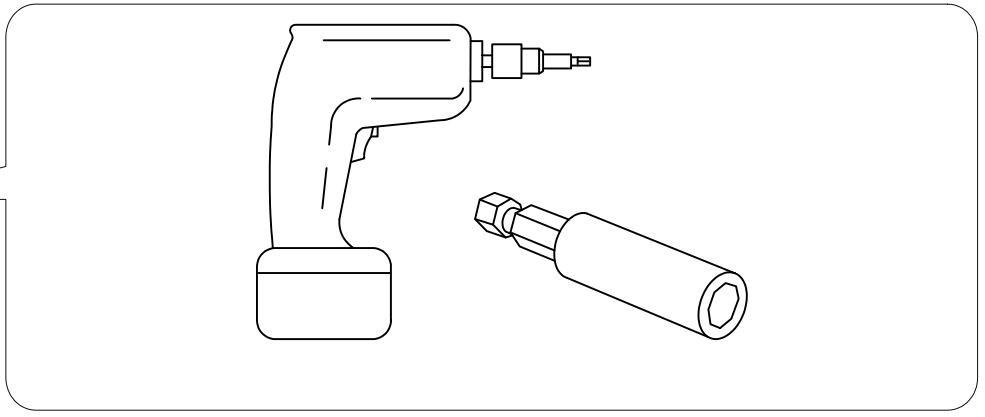

Violent installation is prohibited

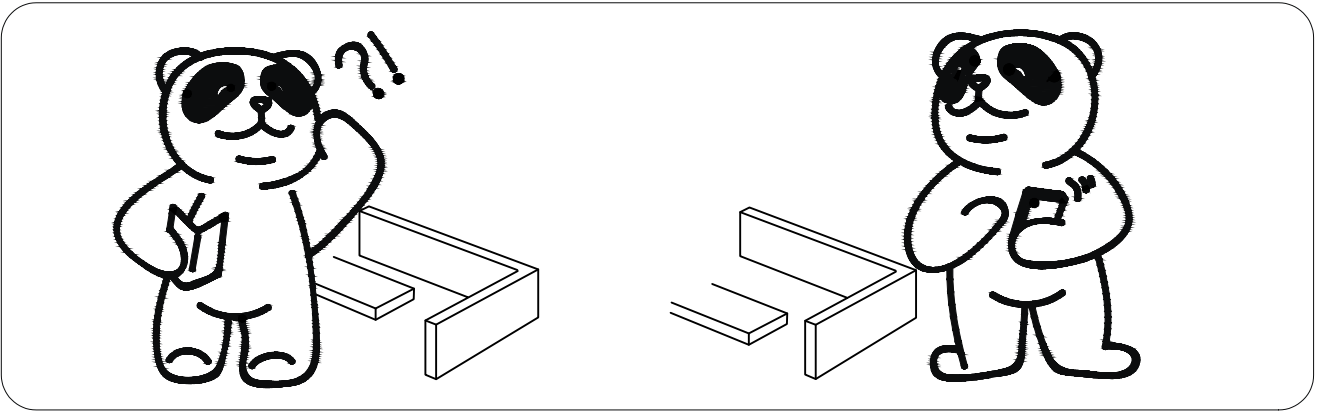

Please call if you need help

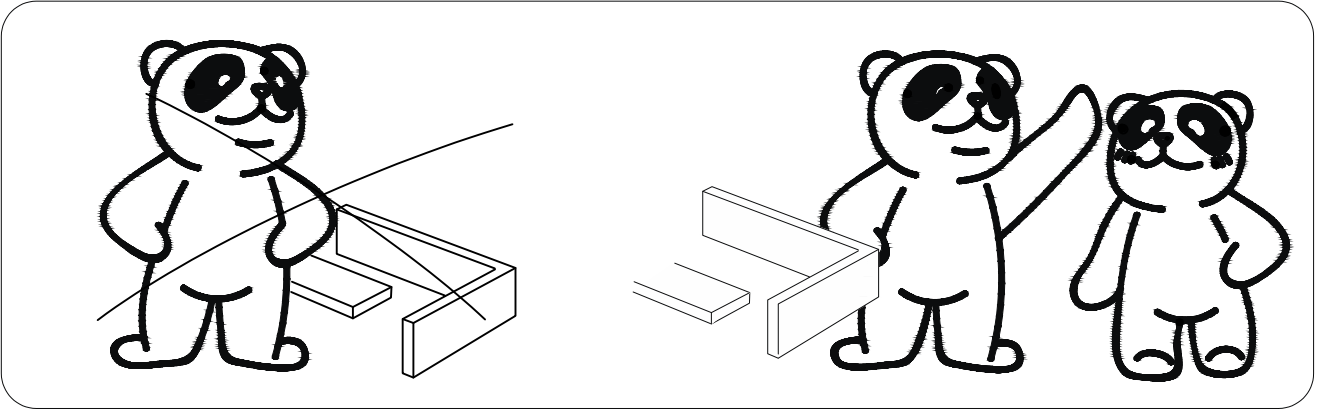

Multi-person cooperation is recommended

Assembly Instruction

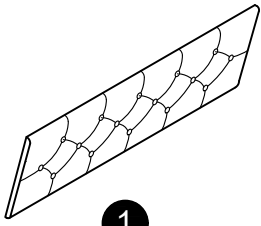

1
X1

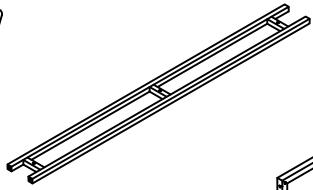

2
X1

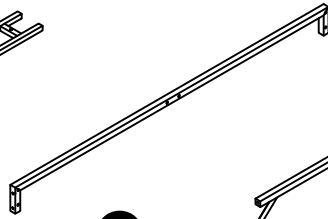

3
X1

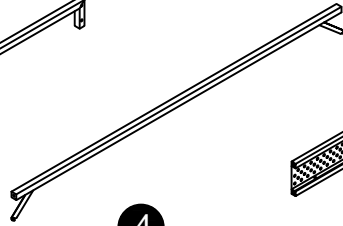

4
X1

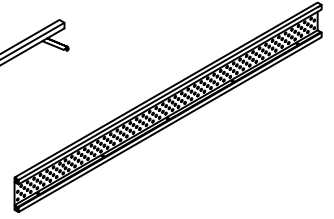

5
X1



6
X2

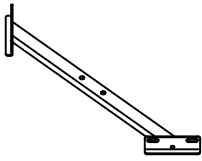

7
X2

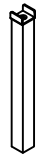

8
X2

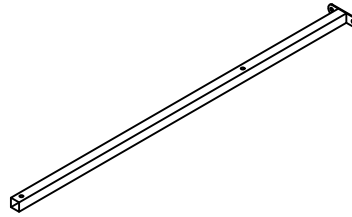

9
X2



10
X1



11
X1

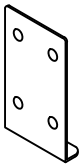

12
X2

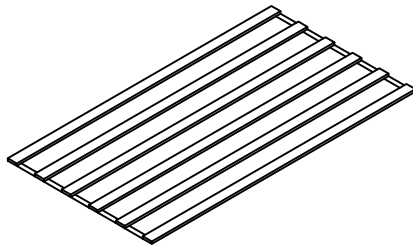

13
X2

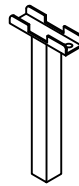

14
X1

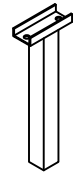

High
15
X2

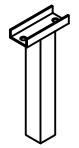

Short
16
X2

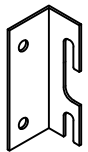

17
X2



18
X2

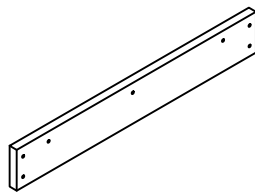

19
X2

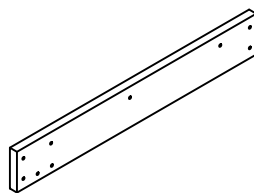

20
X1

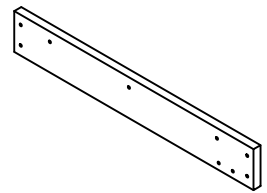

21
X1

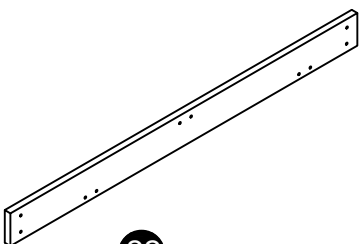

22
X1



23
X2

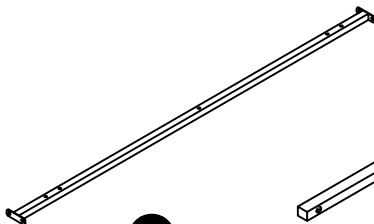

24
X1

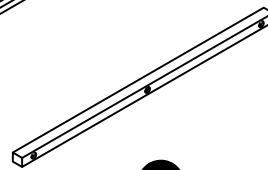

25
X4

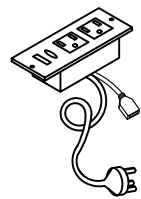

35
X1

Assembly Instruction

Hardware parts 1

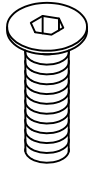

A

M6*12
X8+2

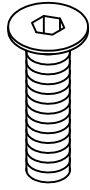

B

M6*20
X42+4

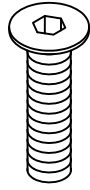

C

M6*28
X4+1

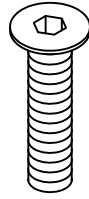

D

M6*33
X8+2

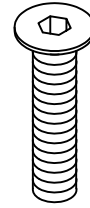

E

M6*35
X24+4

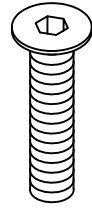

F

M6*45
X16+2

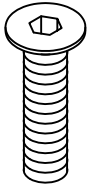

G

M6*25
X4

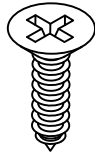

H

M3*12
X2+1

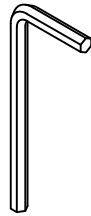

I

M5
X1

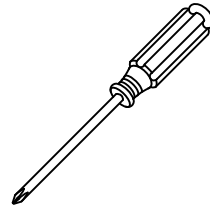

J

X1

Assembly Instruction

Sheet accessories

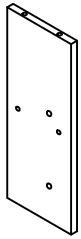

26
X1

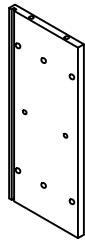

27
X2



29
X1

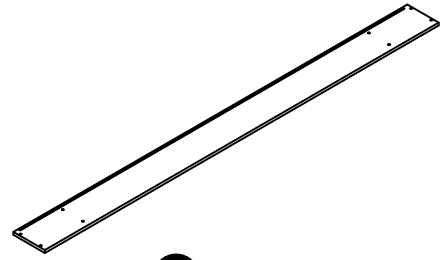

30
X1

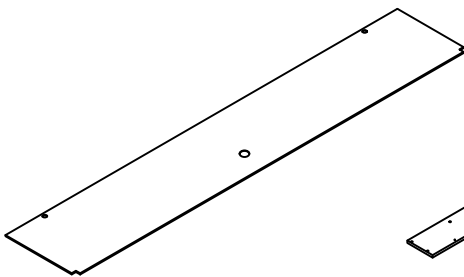

31
X1

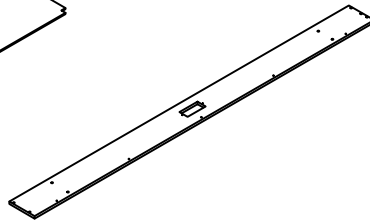

32
X1

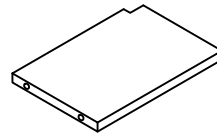

33
X2

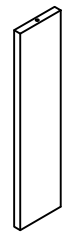

34
X2

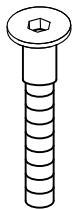

L
M5*30
X5+1

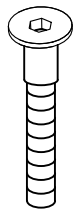

M
M5*35
X28+2

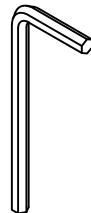

N
M3
X1

Assembly Instruction

LED light strip electronic accessories list

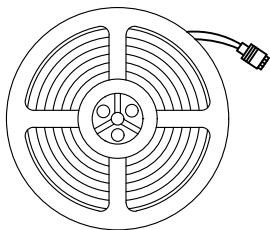

Adhesive light bar X1

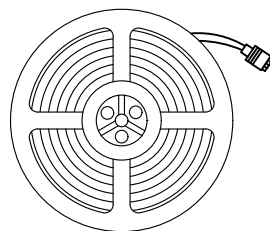

Velcro light bar X2

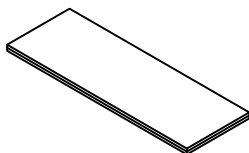

Strap magic tape X4

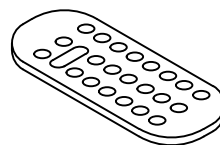

Remote control X1

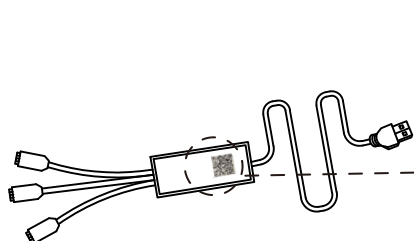

Power cord X1

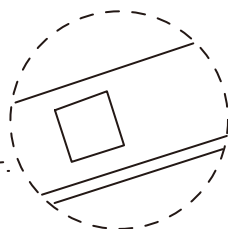

There is a two-dimensional code at the position of the power line.

Assembly Instruction

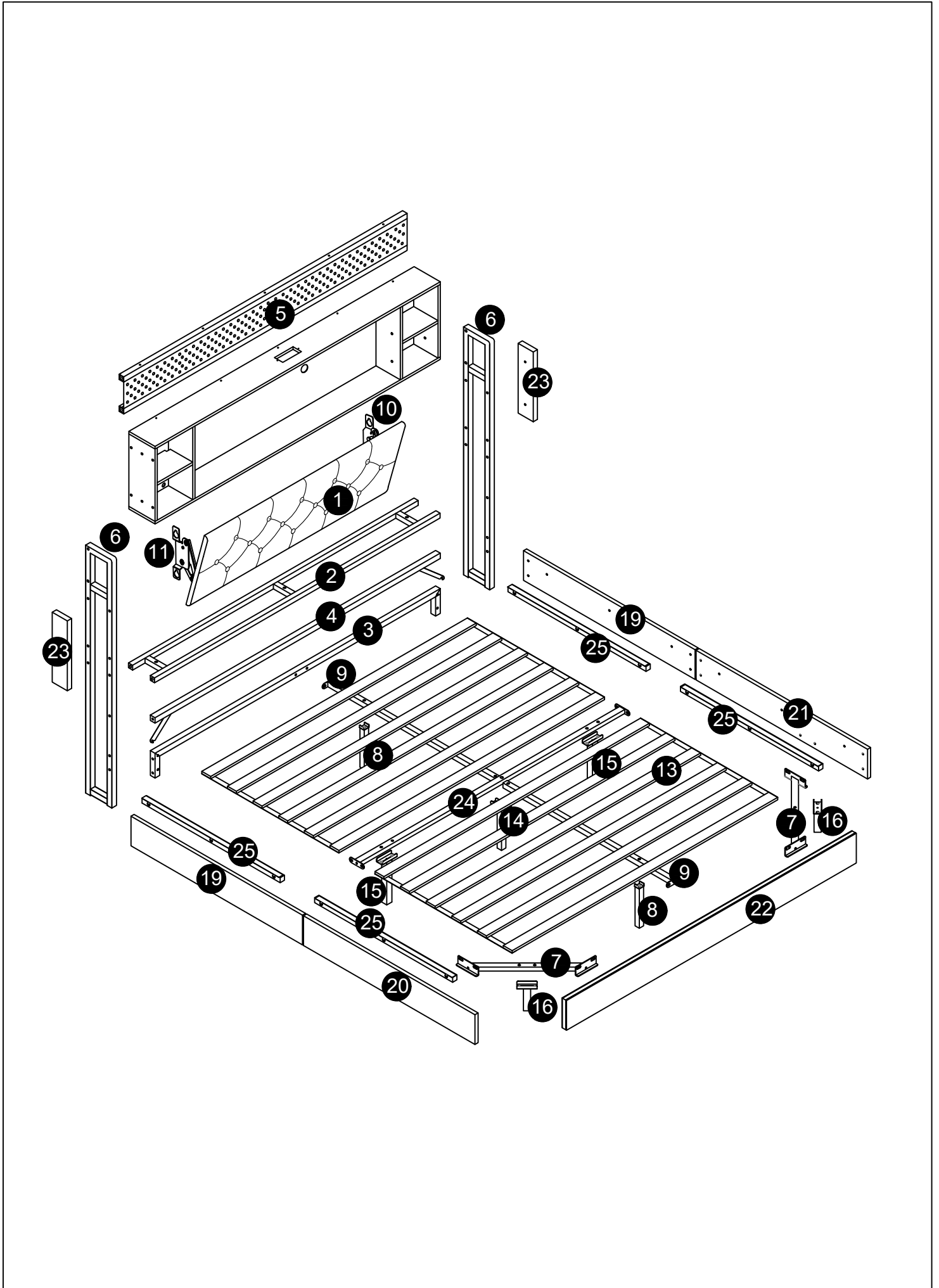

Assembly Instruction

Assembly instruction of Bedside cabinet Exploded general view

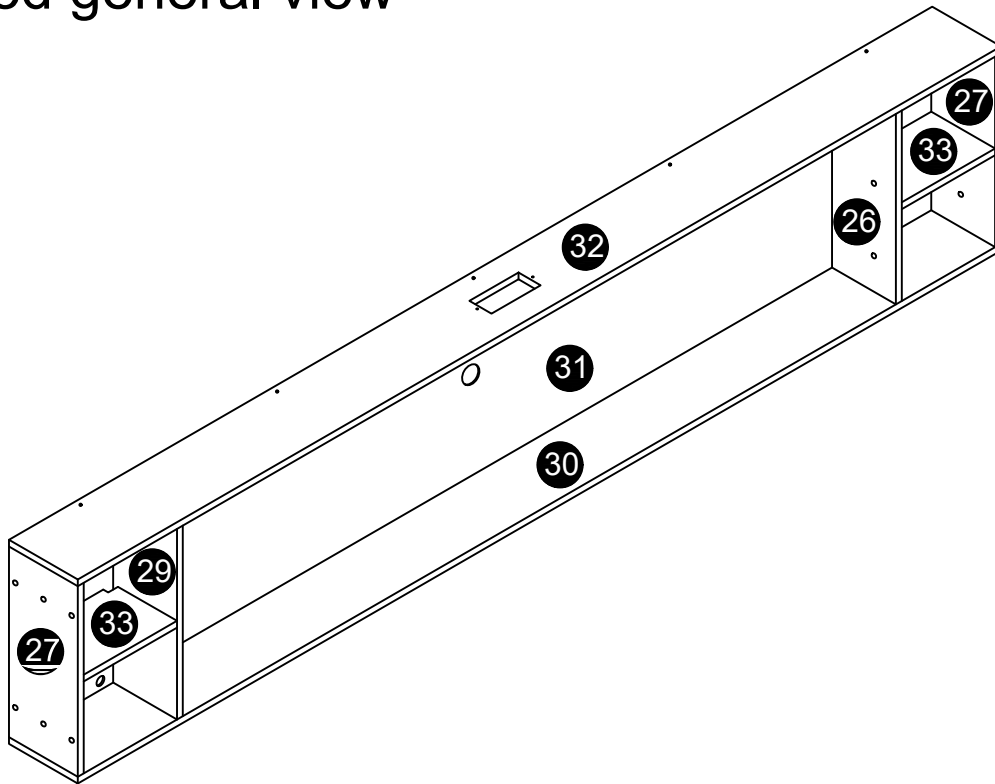

1

Note that boards 29 and 26 have edge sealing directions

M M5*35

X8

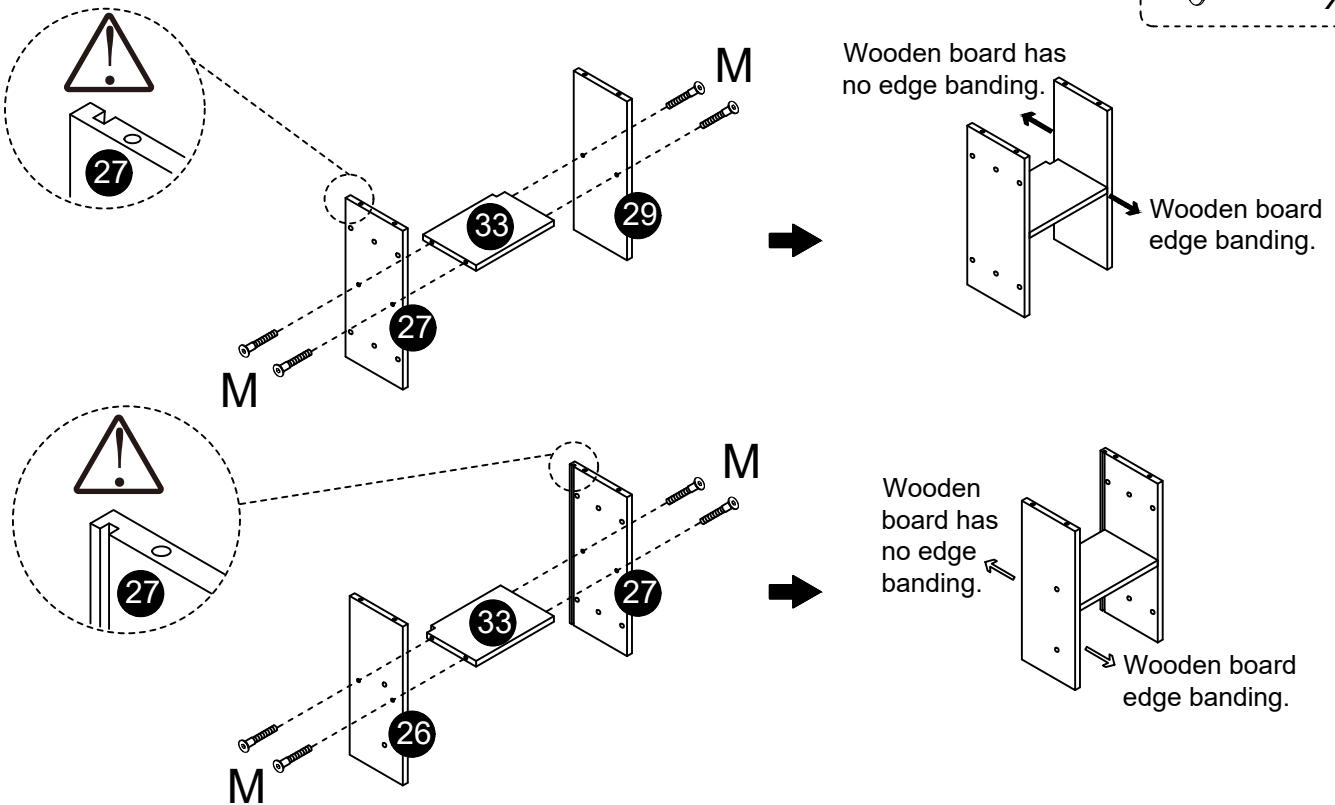

Assembly Instruction

2

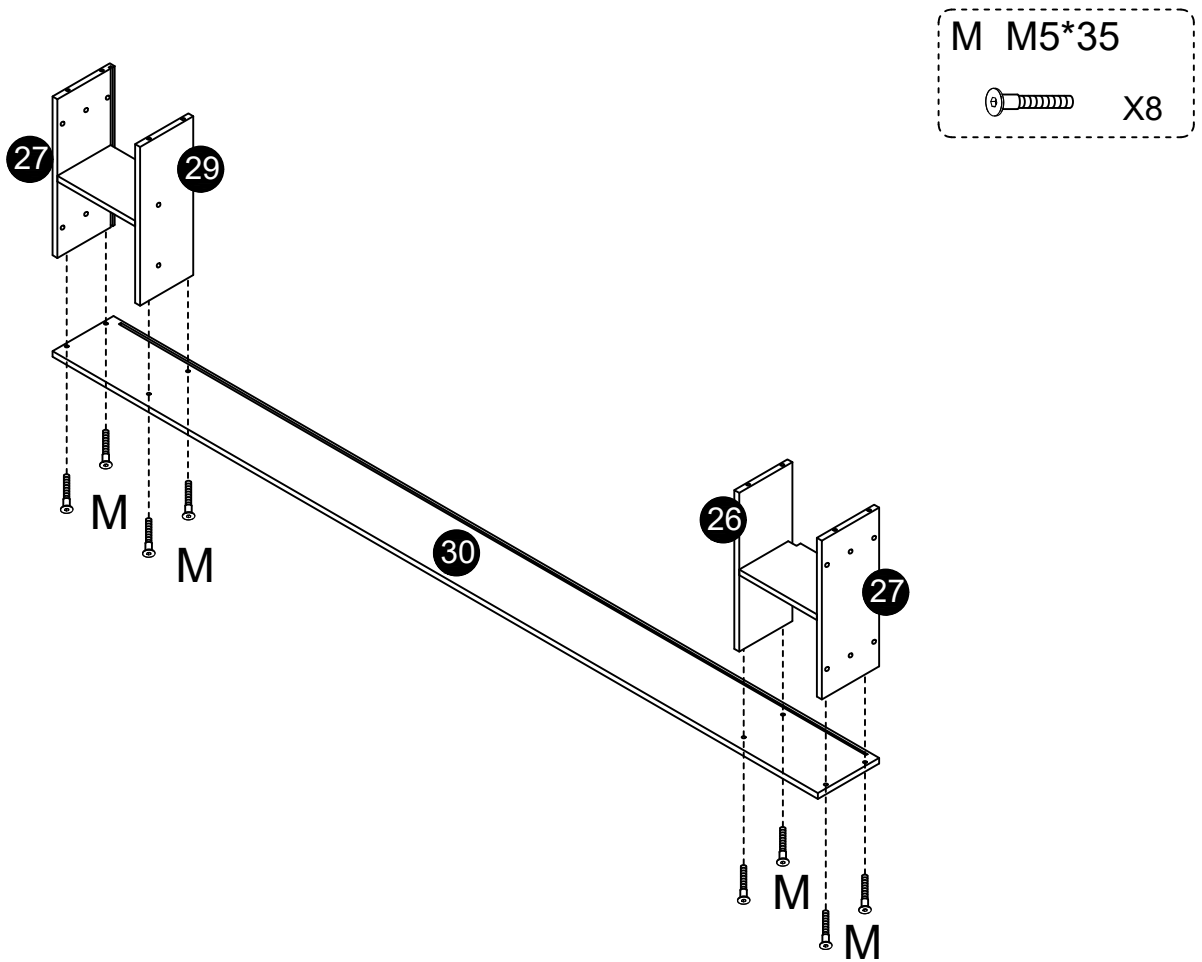

3

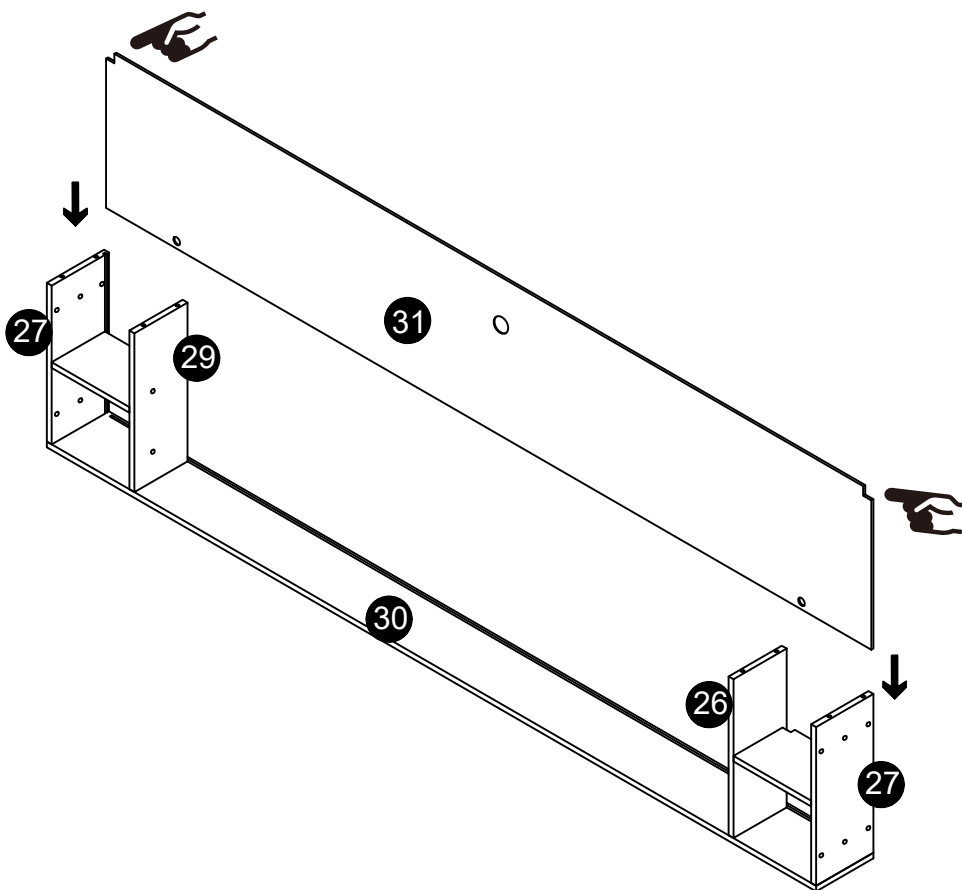

Assembly Instruction

4

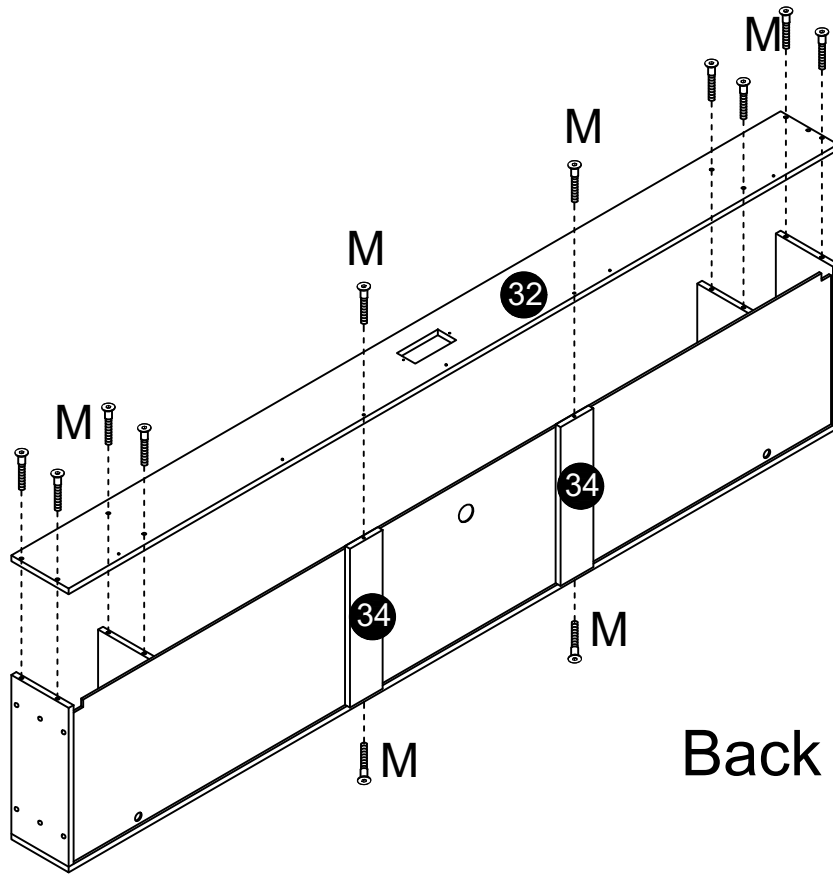

M M5*35
X12

5

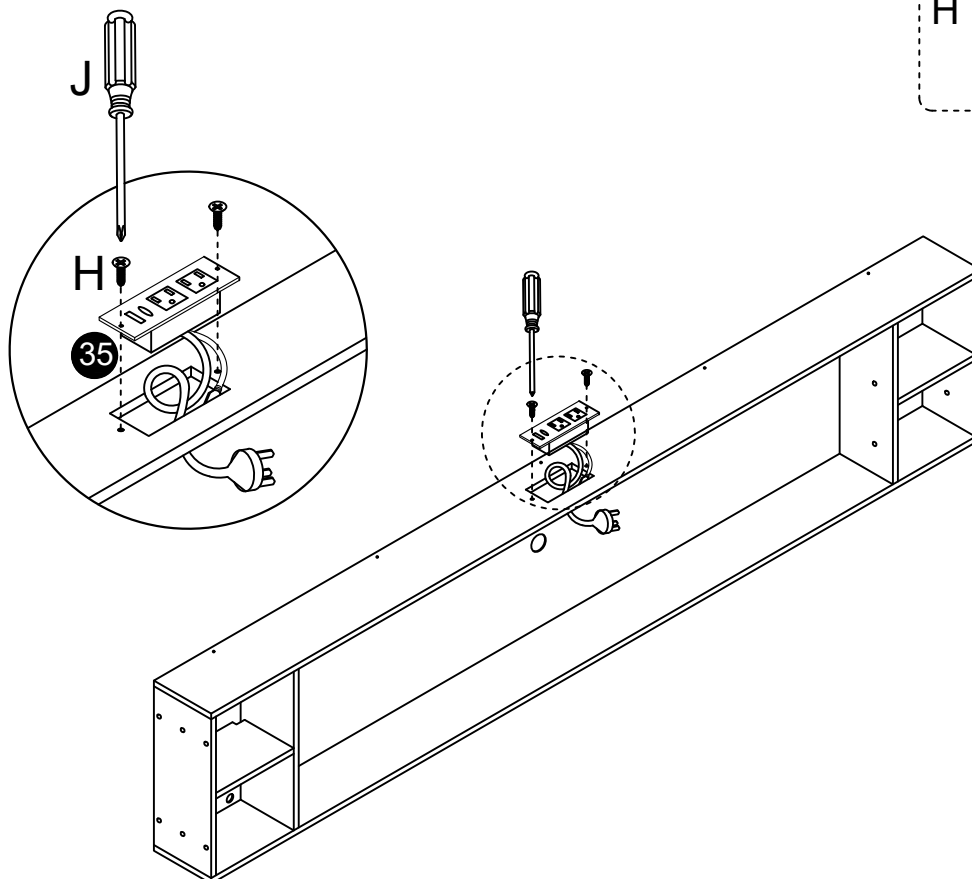

H M3*12
X2

Assembly Instruction

6

L M5*30
X5

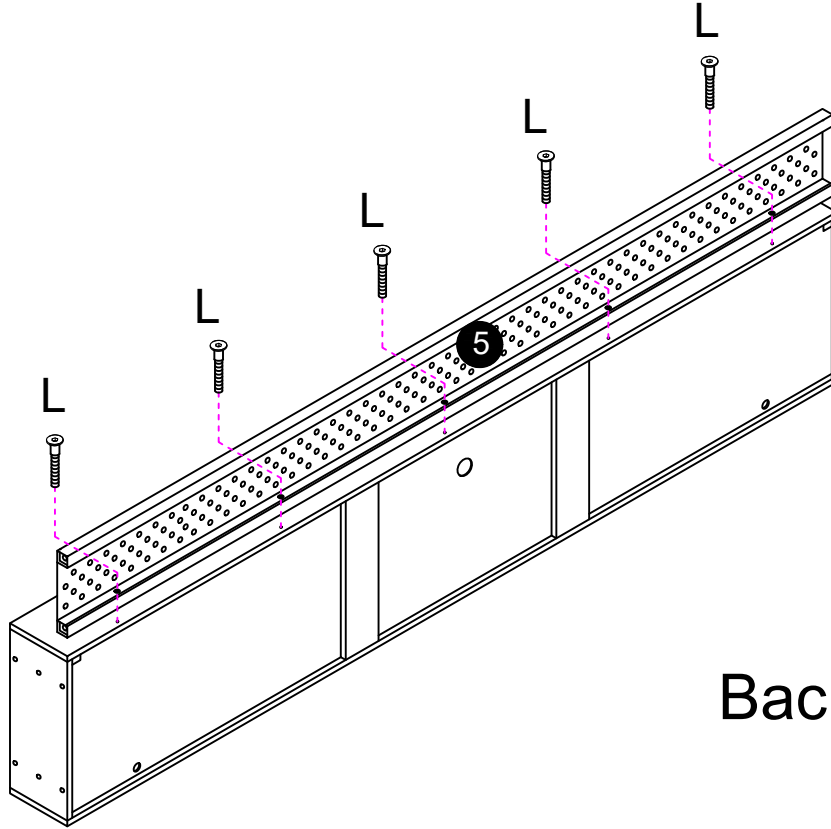

Back

7

F M6*45
X10

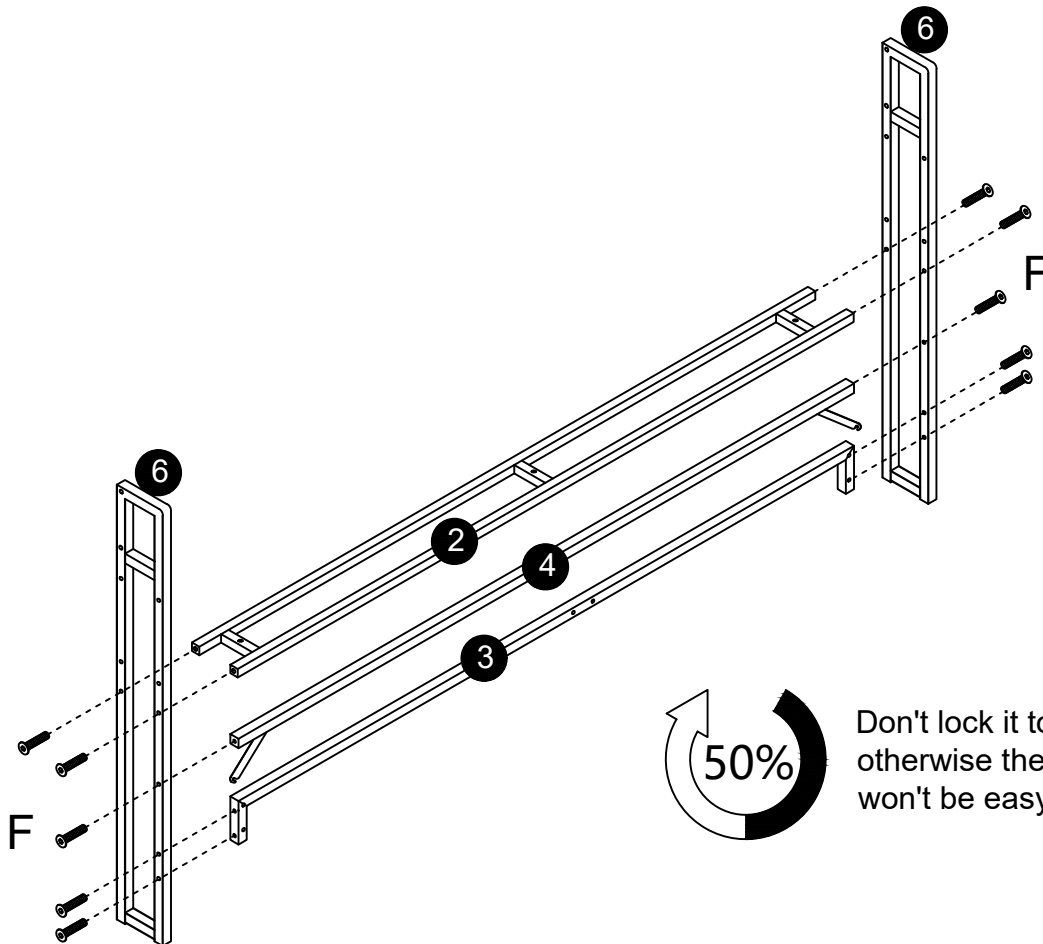

Don't lock it too tightly for now, otherwise the head of the bed won't be easy to install.

Assembly Instruction

8

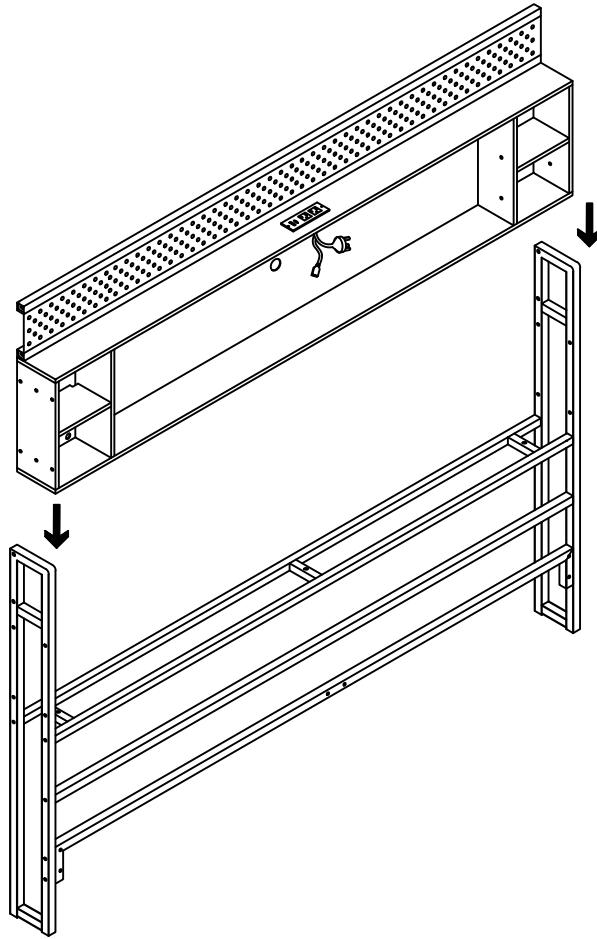

9

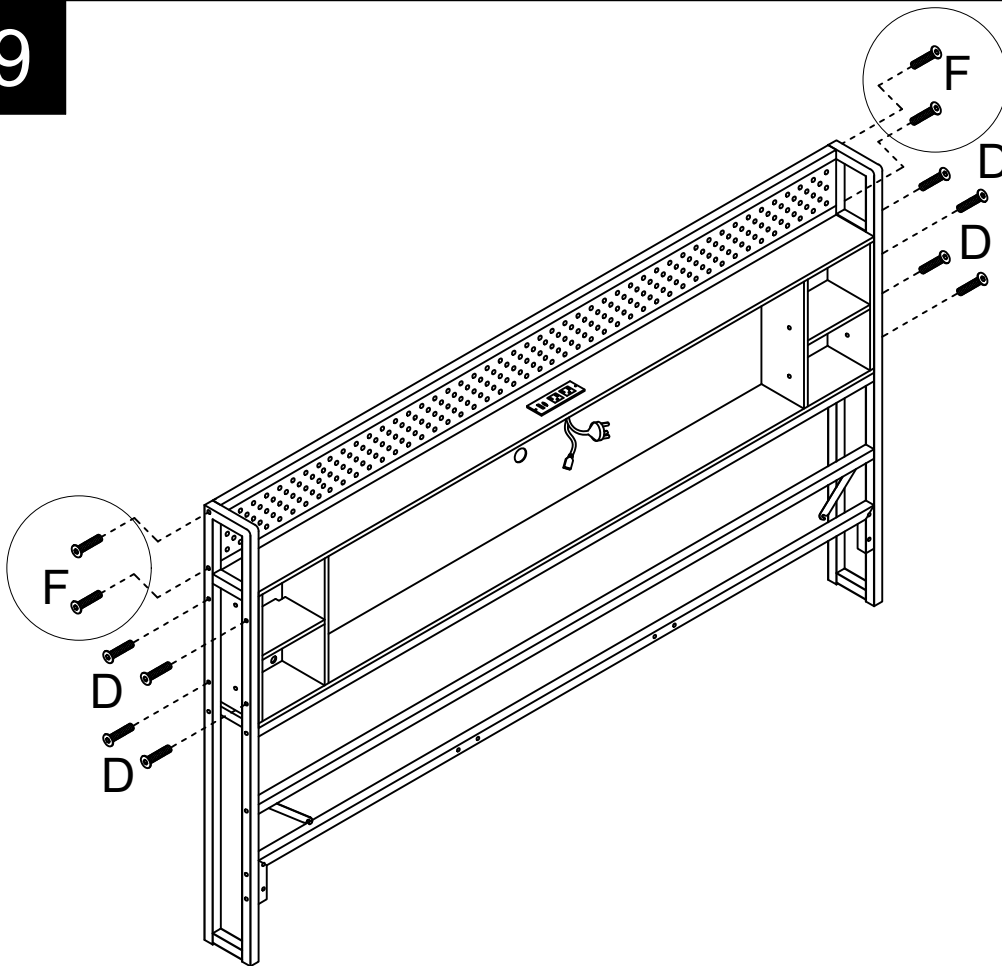

D M6*33
X8

F M6*45
X4

Assembly Instruction

10

C M6*28
 X3

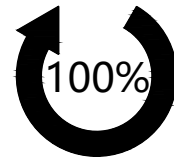
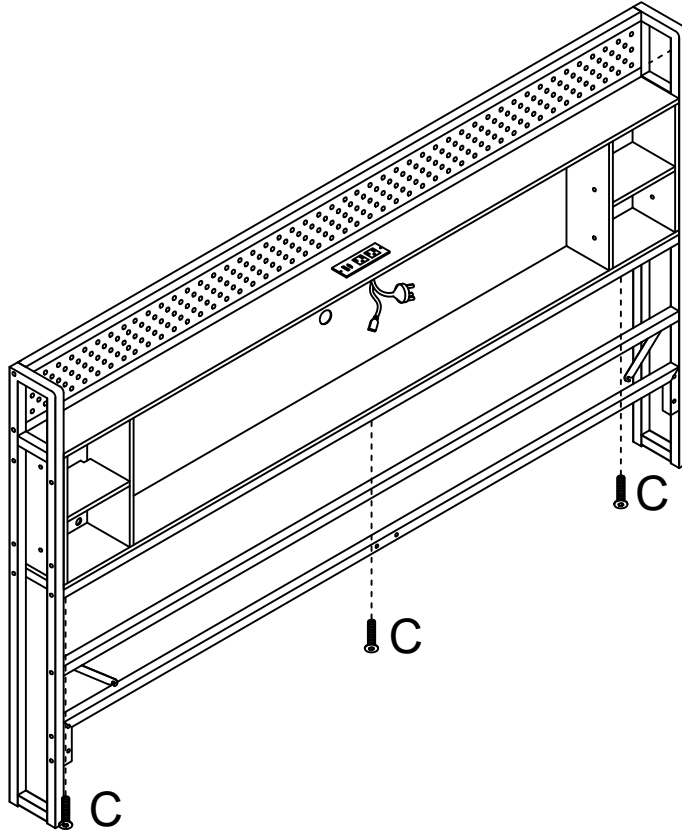

After installing the cabinet,
tighten the screws.

11

G M6*25
 X4

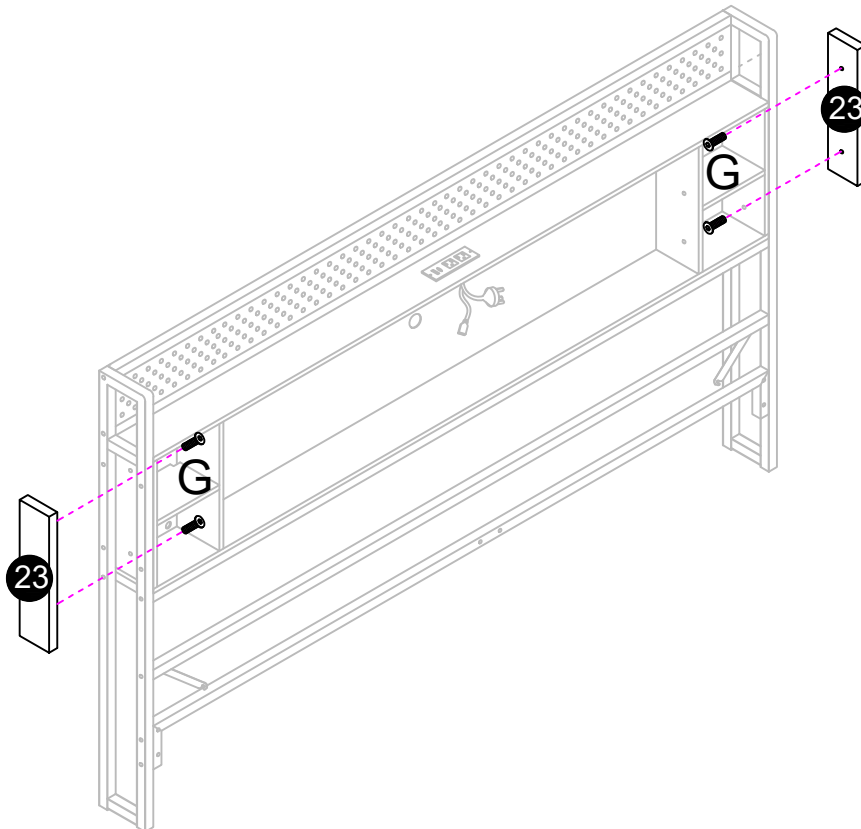

Assembly Instruction

12

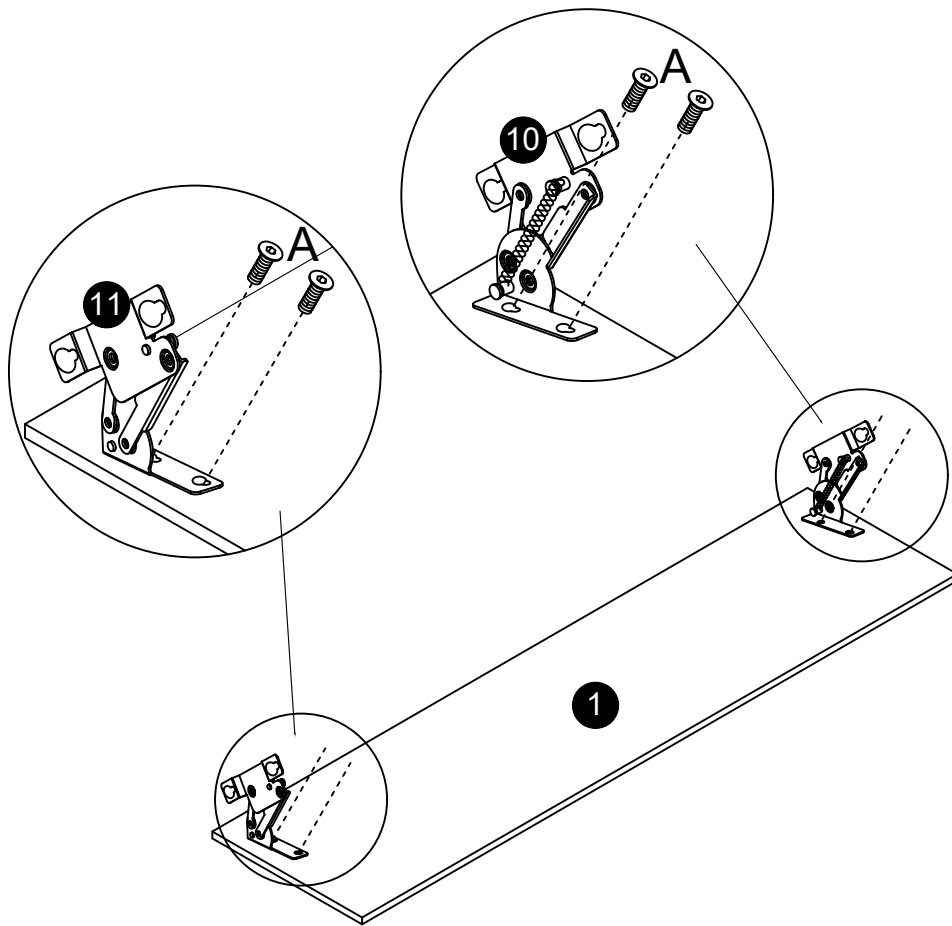

A M6*12
 X4

13

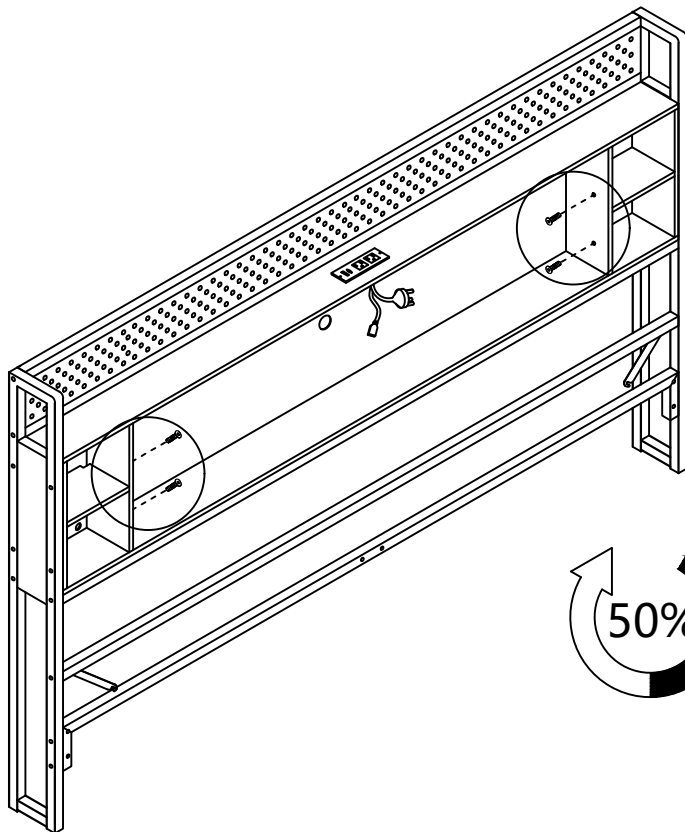

A M6*12
 X4

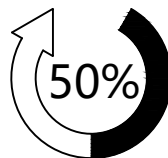
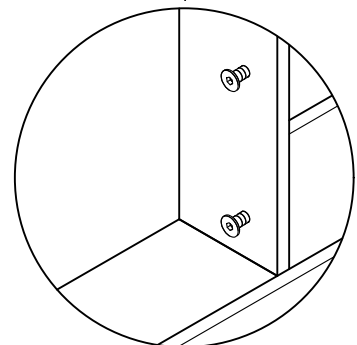
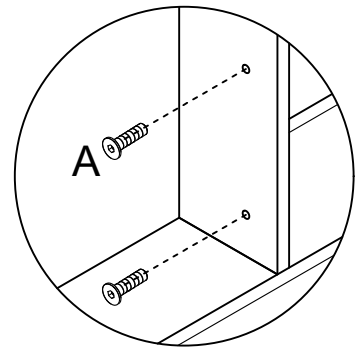

Assembly Instruction

14

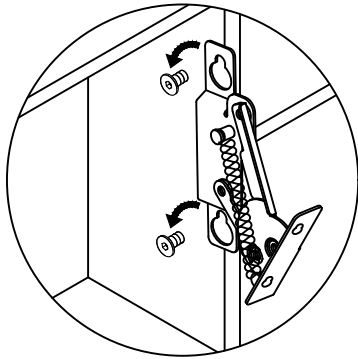

Hang it up first

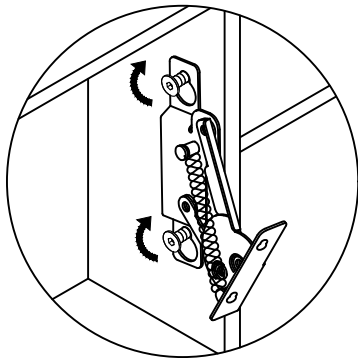

Lock it, don't use
fore to lock it.

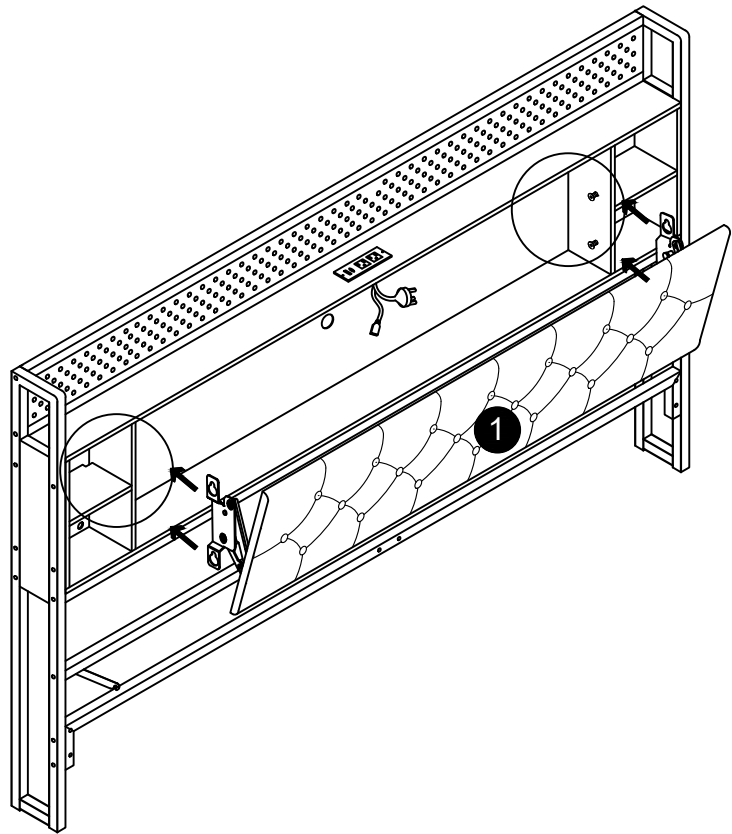

15

B M6*20

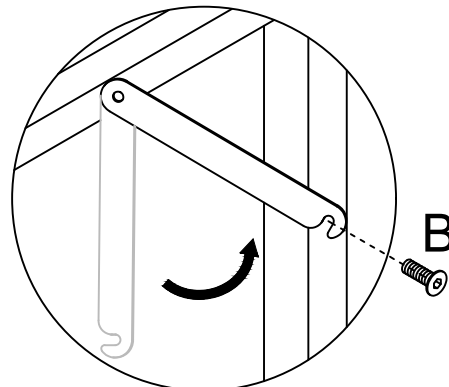
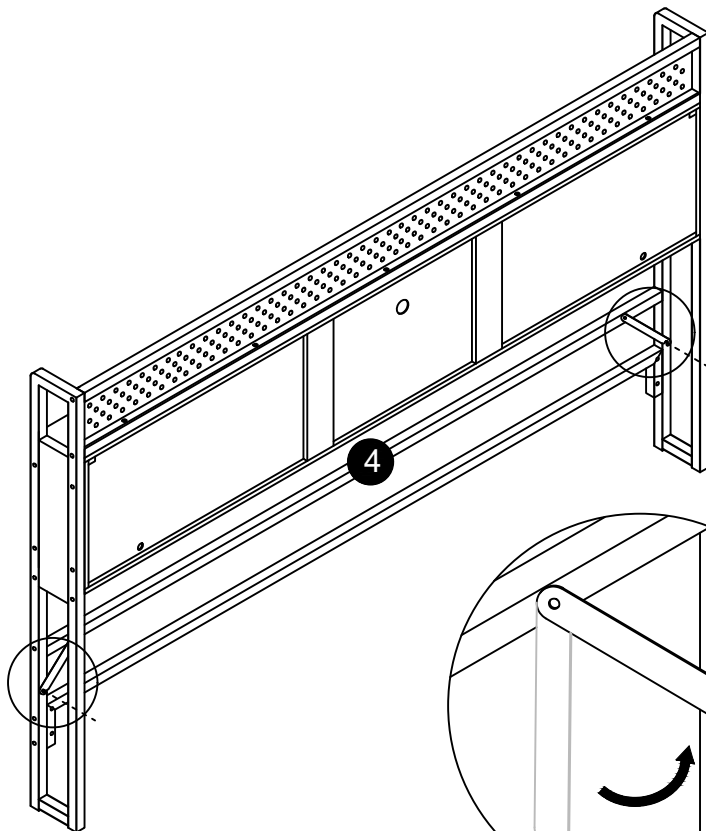

Assembly Instruction

16

E M6*35
X12

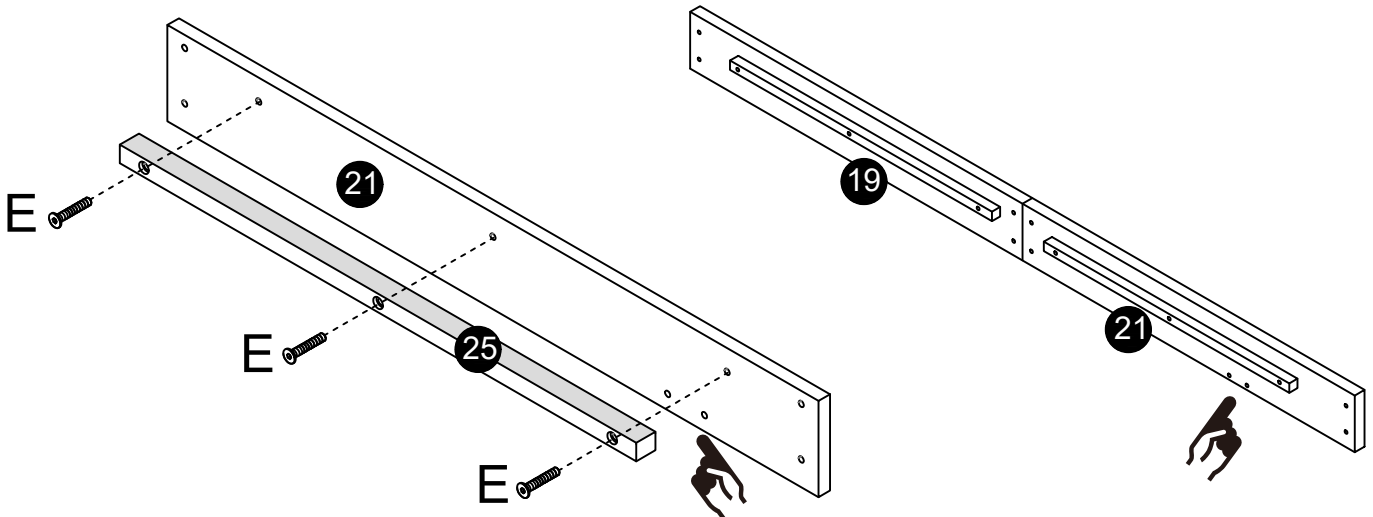
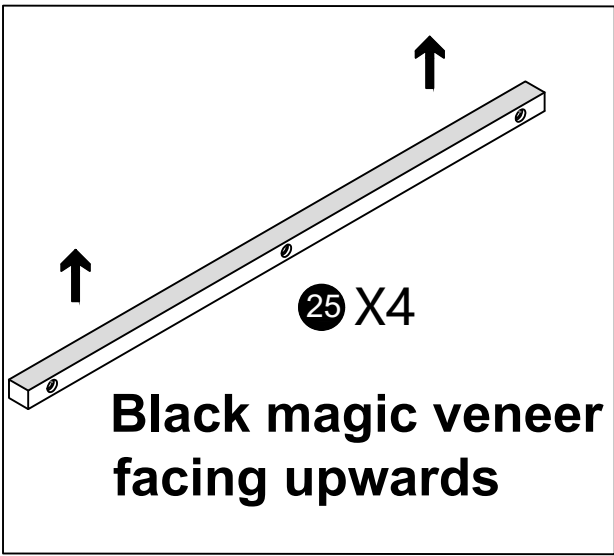
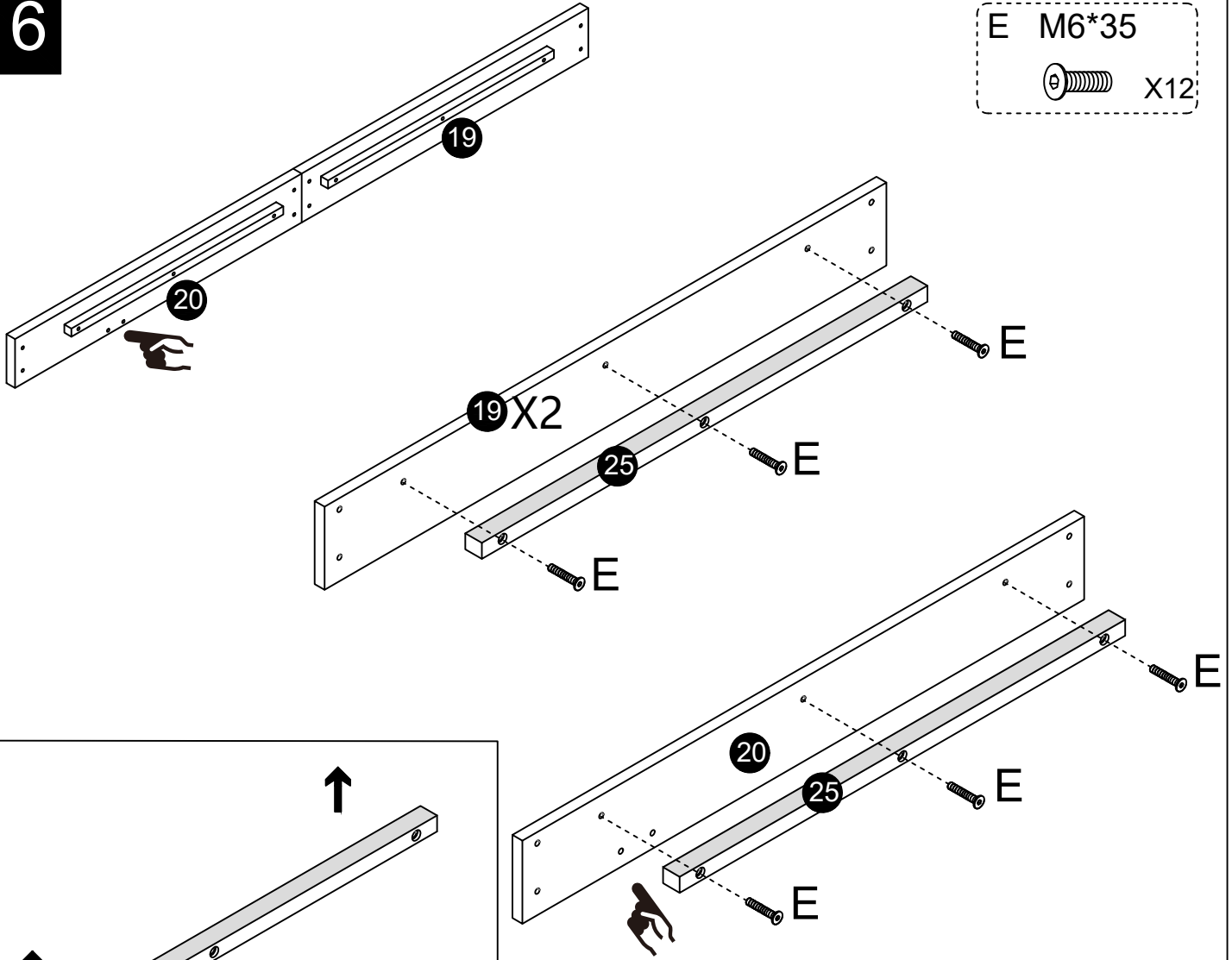

Assembly Instruction

19

Hang it up

B M6*20

 X4

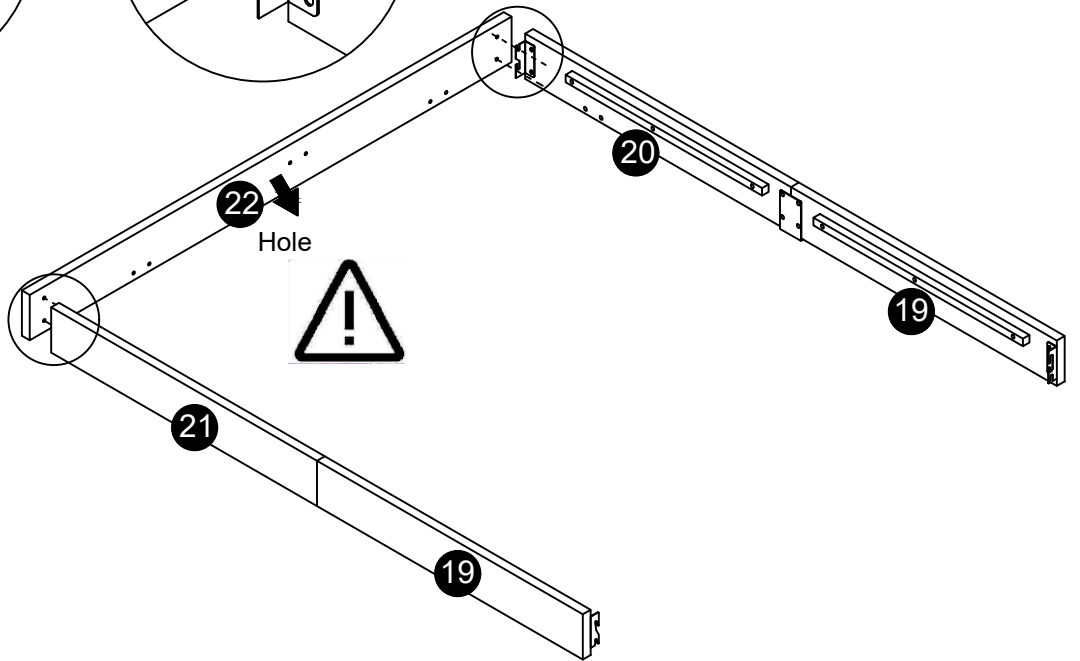
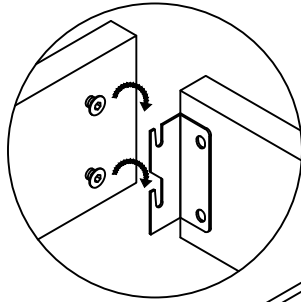
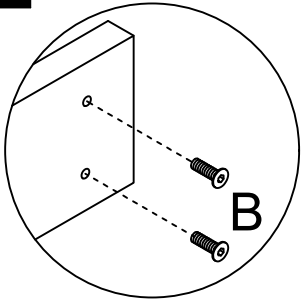

20

B M6*20

 X4

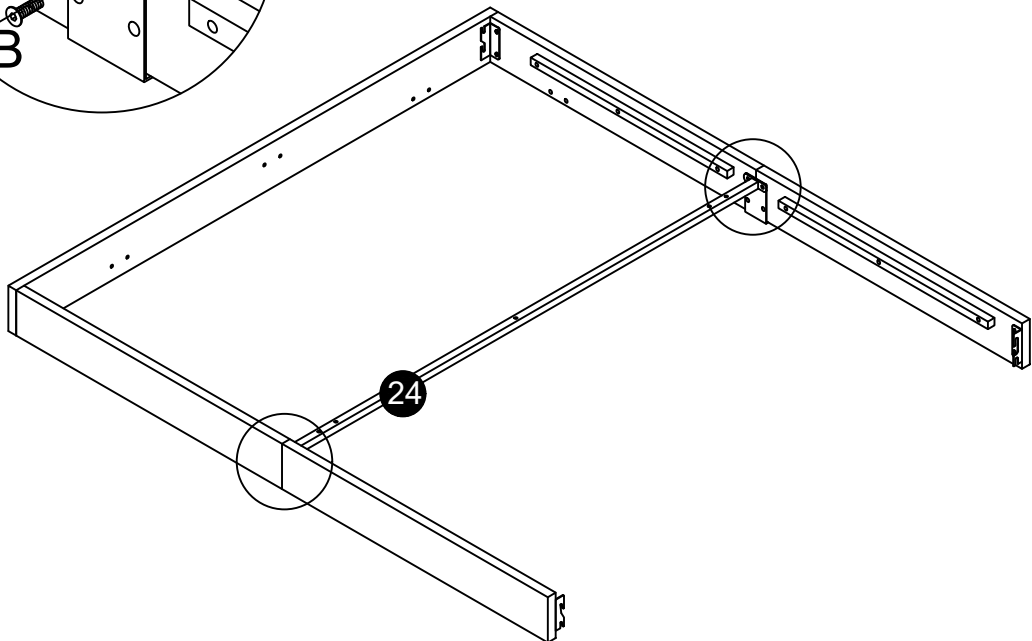
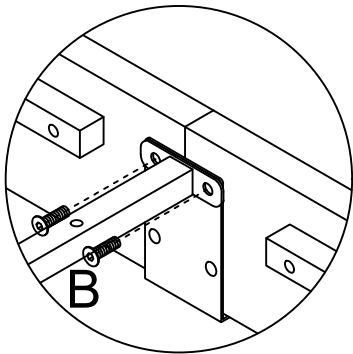

Assembly Instruction

21

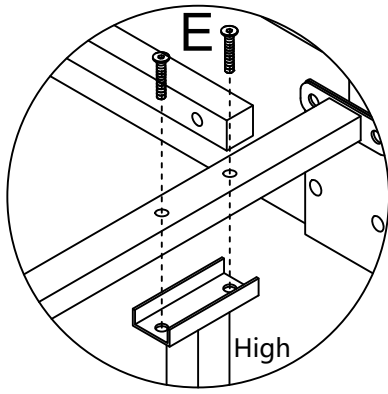

E M6*35

X4

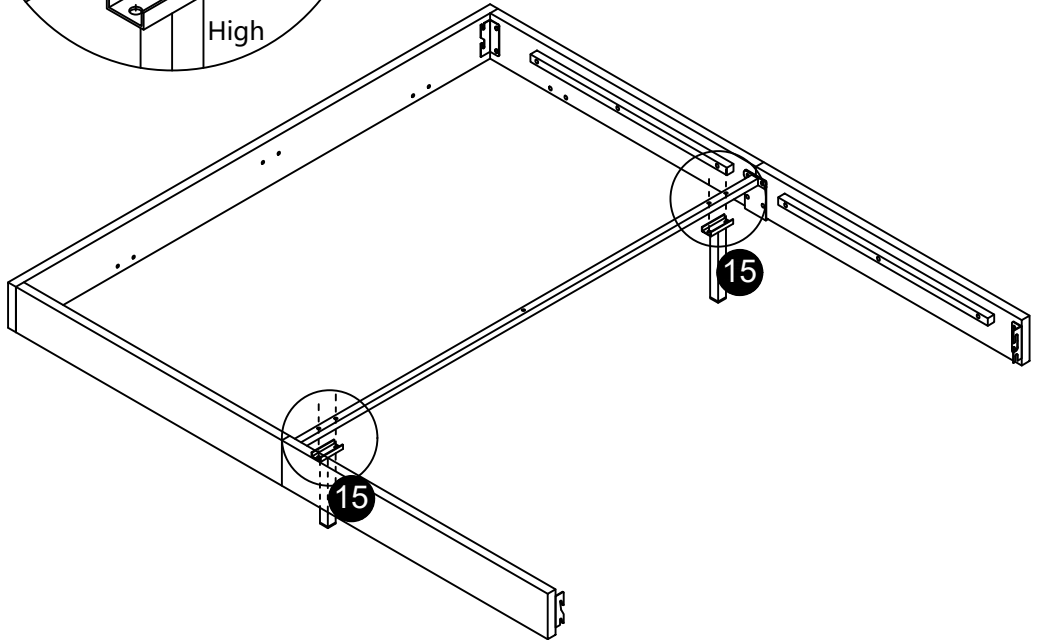

22

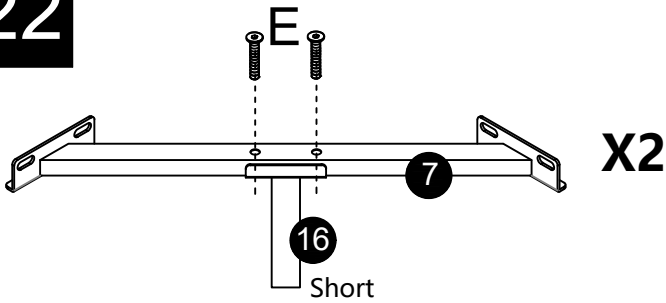

X2

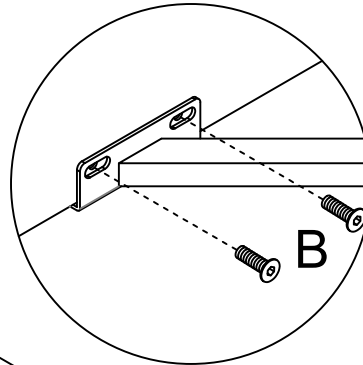

B M6*20

X8

E M6*35

X4

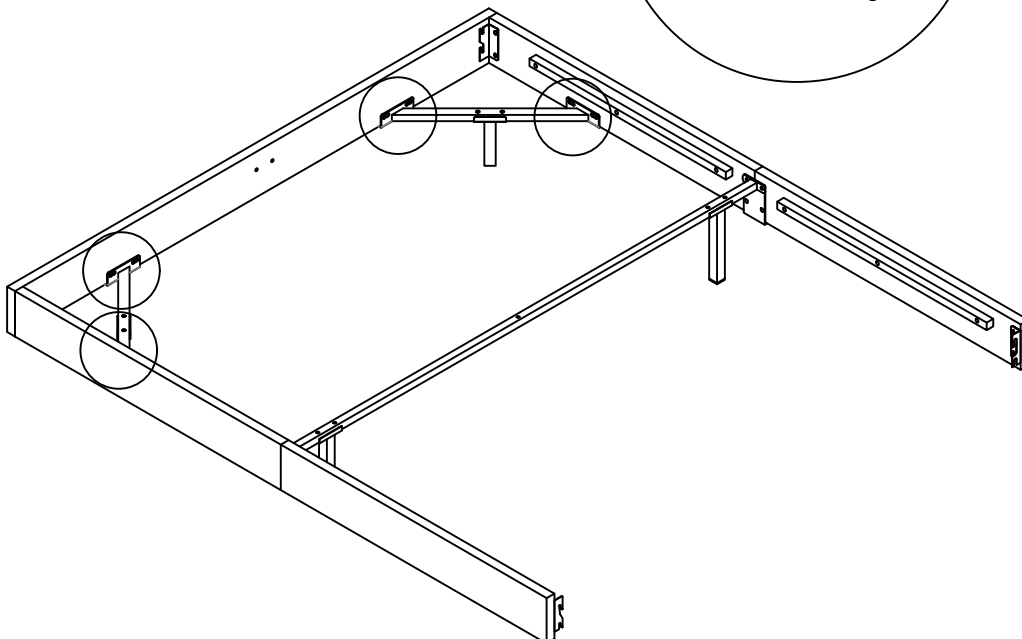

Assembly Instruction

23

E M6*35

 X2

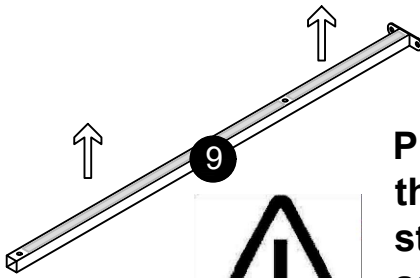

Please be sure to pay attention to the fact that there are mute stickers facing upwards during assembly, and the material feels soft to the touch

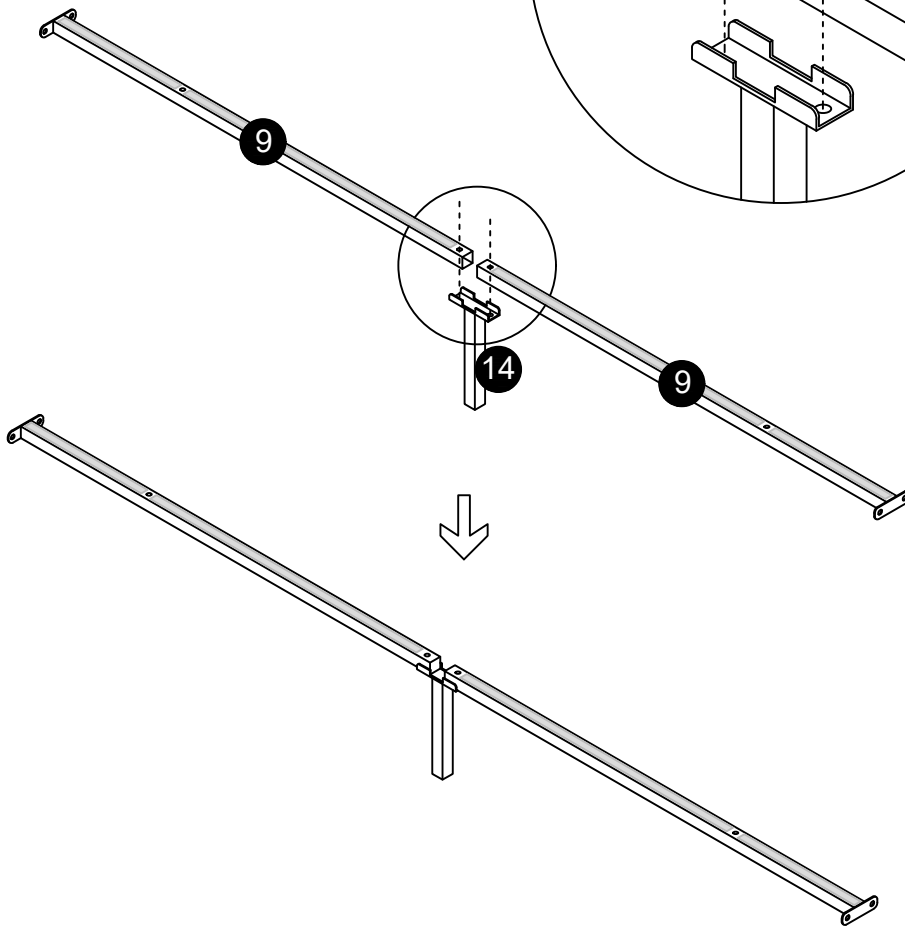
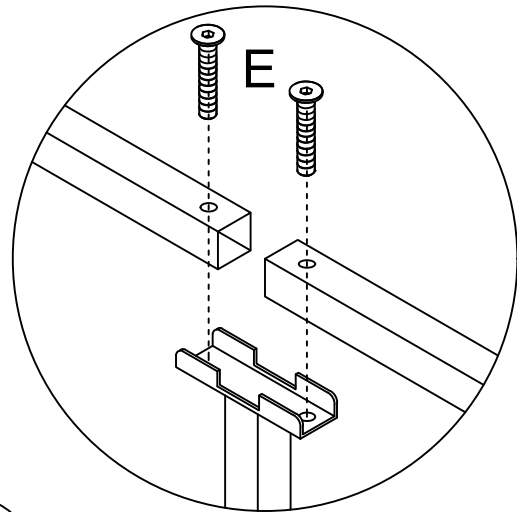

Assembly Instruction

24

F M6*45

 X1

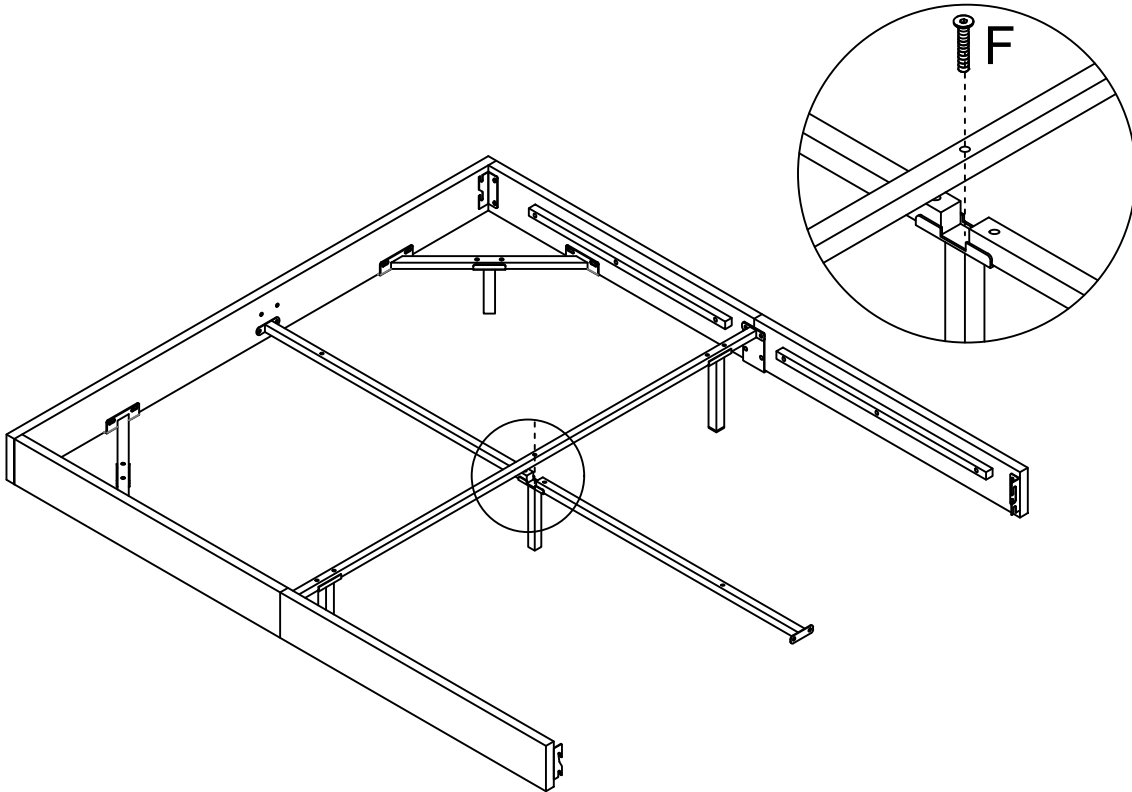

25

B M6*20

 X2

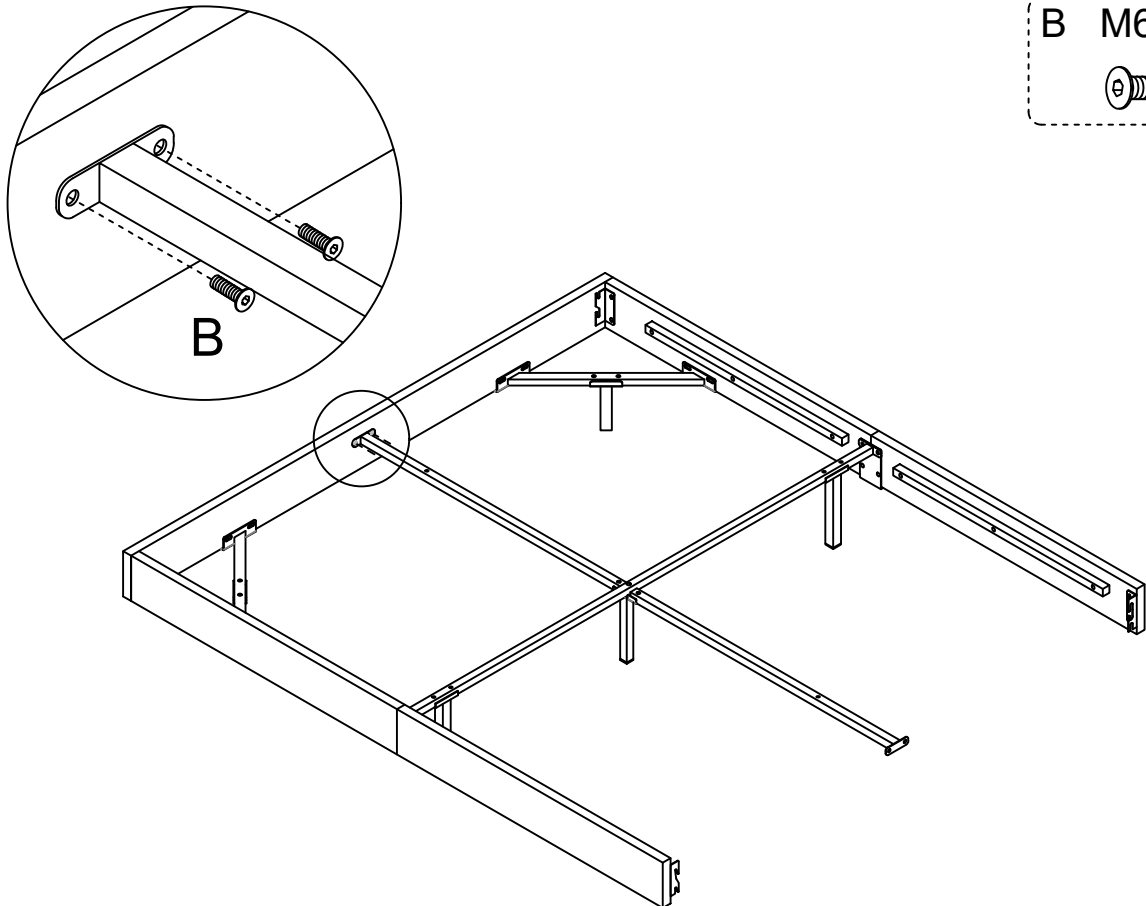

Assembly Instruction

26

B M6*20



X6

Hang it up

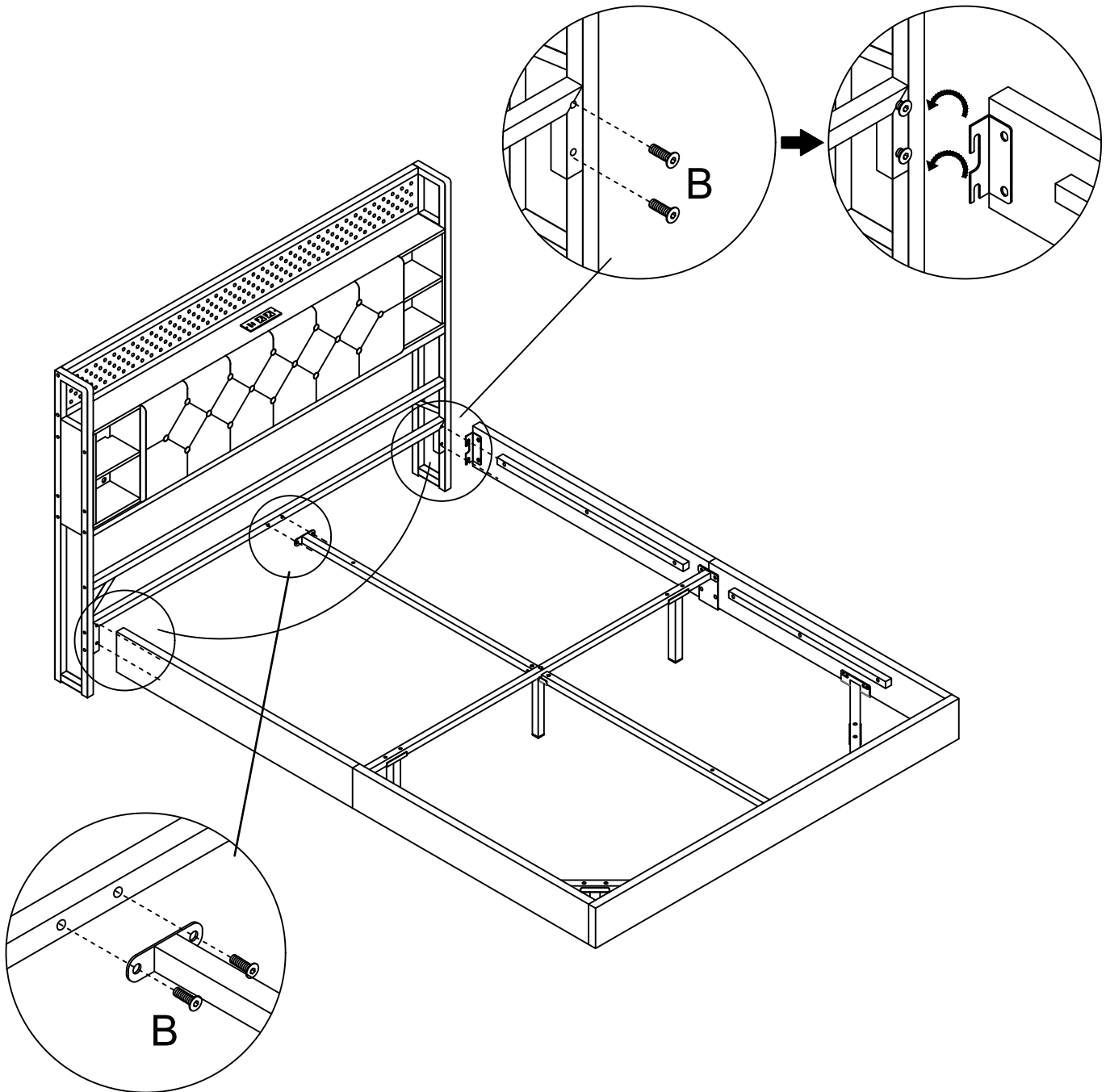

Assembly Instruction

27

E M6*35

 X2

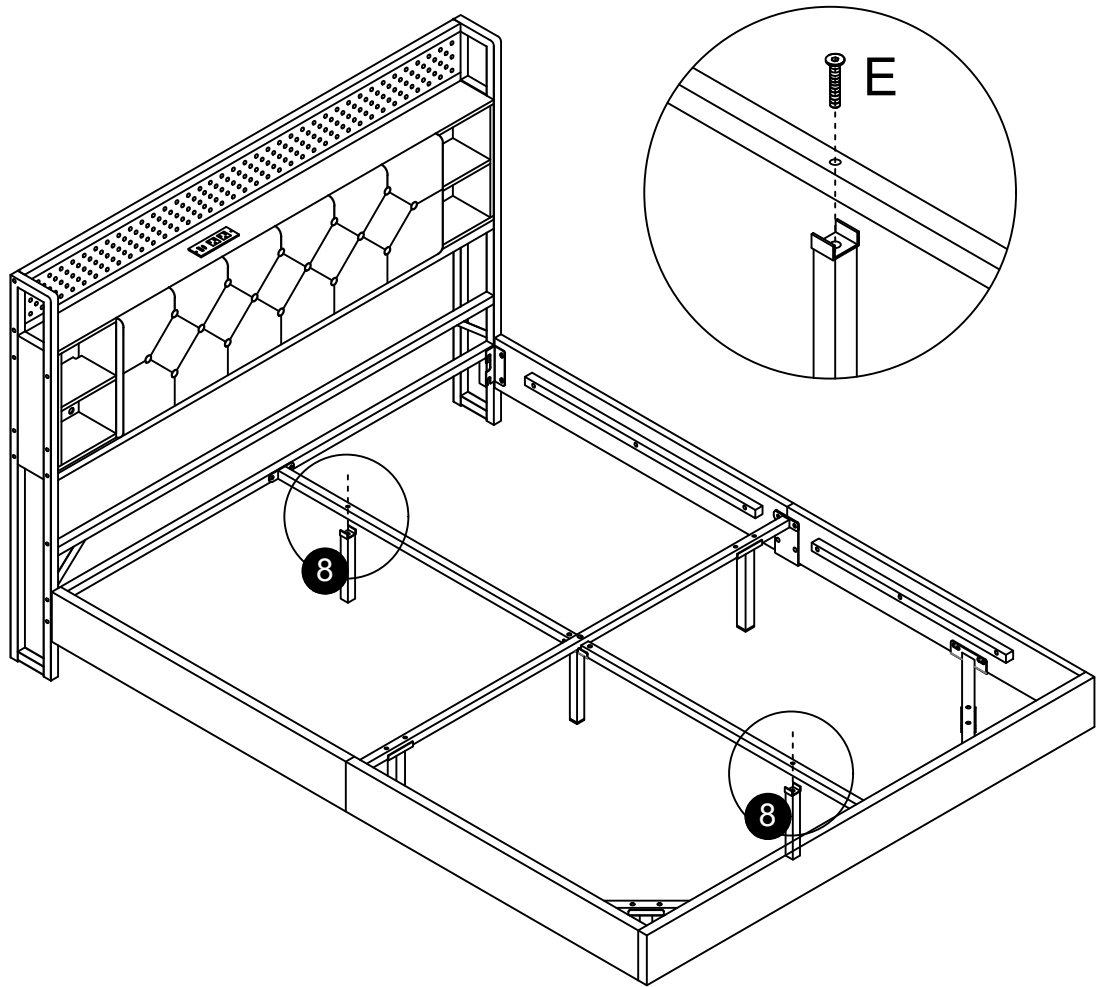

Assembly Instruction

28

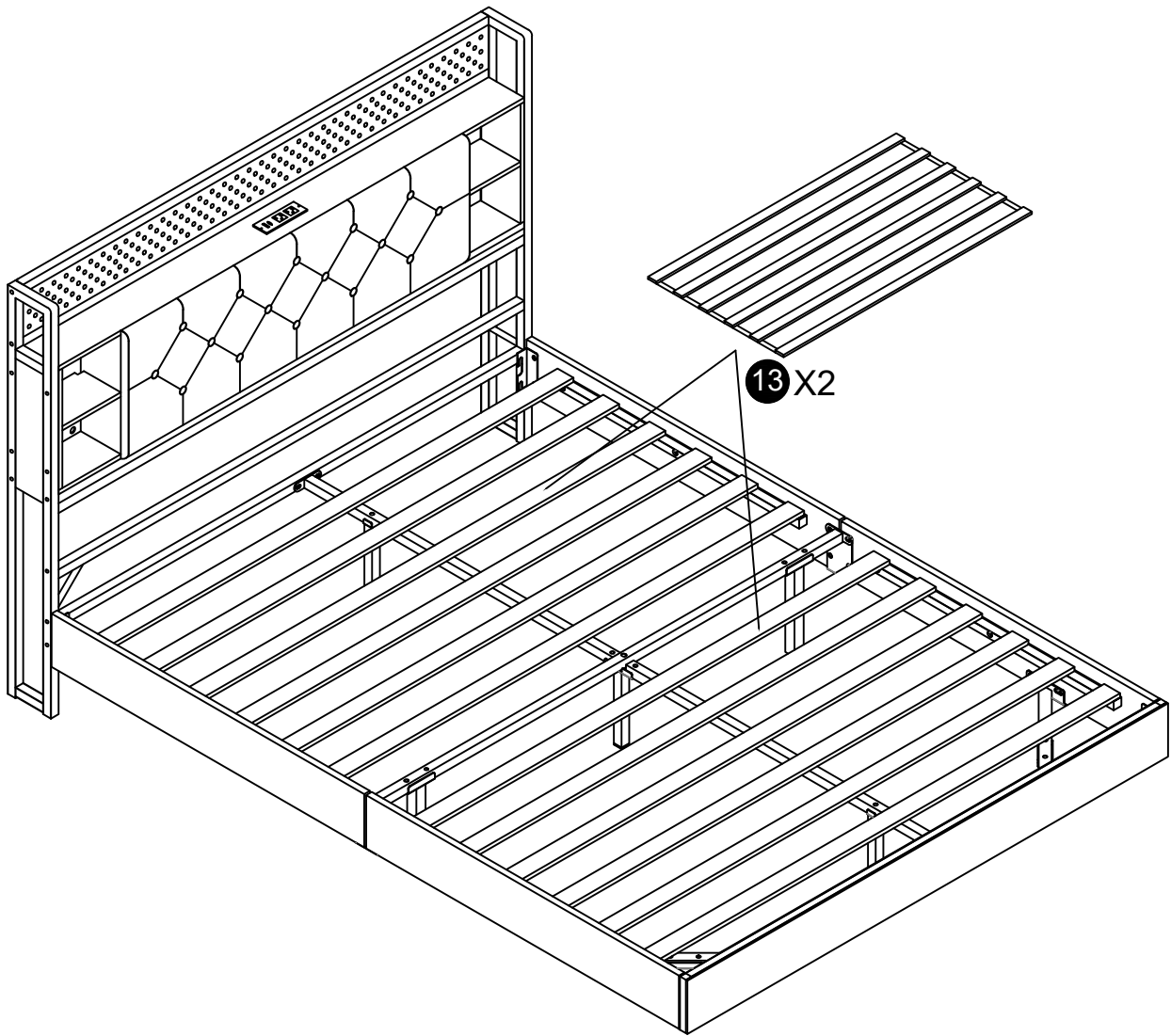

Assembly Instruction

29

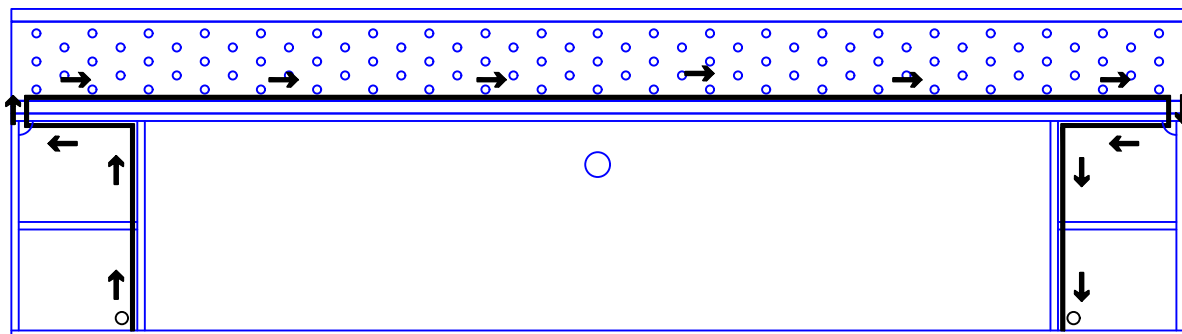

In order to better reflect the assembly process of LED light belt, this drawing adopts the exploded view of bed cabinet.

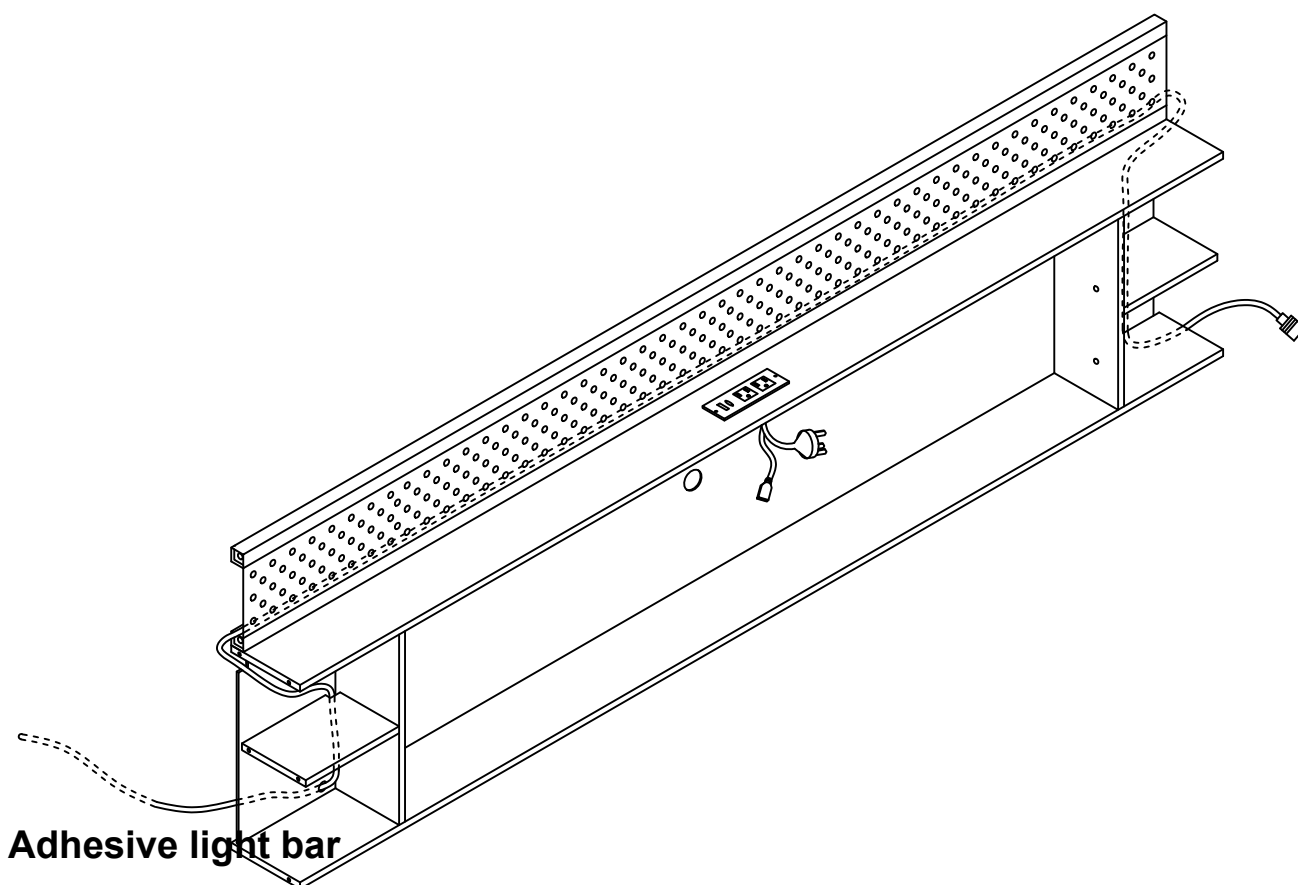

Please pass the light strip through the holes in sequence as shown in the diagram and exit from the holes in the rear panel.

Please note that the adhesive surface should be attached to the inner winding surface for optimal use.

Assembly Instruction

30

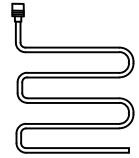
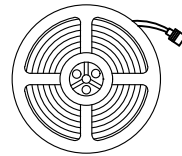

Pull out
Velcro light bar and unfold **Velcro light bar**

The unfolded light strip has a light strip surface on one side and a magic veneer on the other side

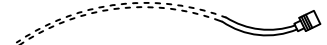
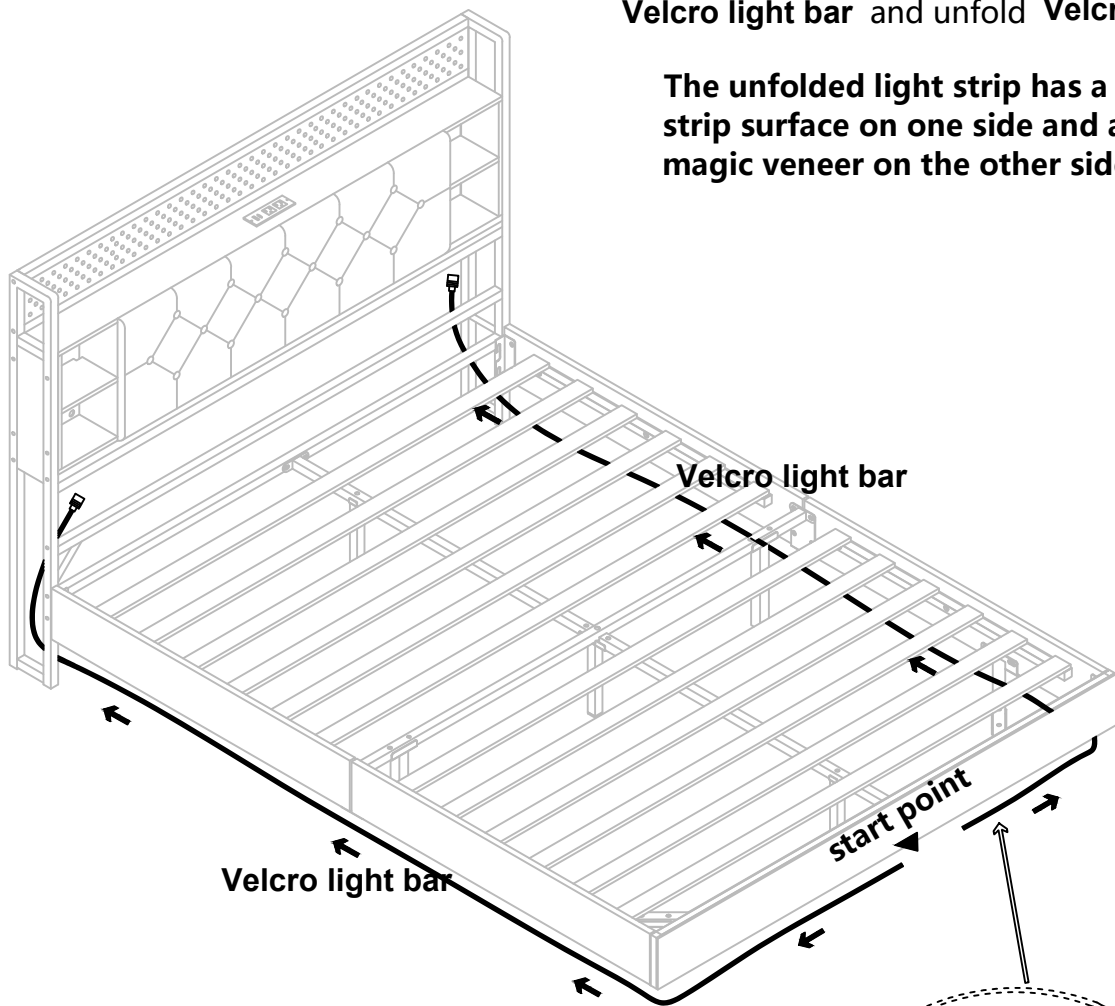

At the bottom
Stick the light strip on

Assembly Instruction

31

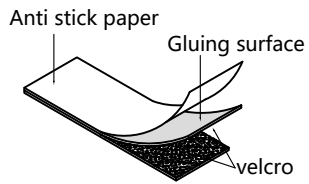

Strap magic tape

When the wires are disordered, tear off the anti stick paper, paste it on the place where the wires pass, and then bind the wires.

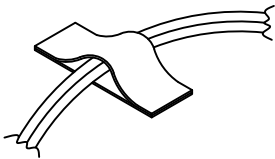

There is a USB bus under the socket, connect the USB plug of the power cord to it.

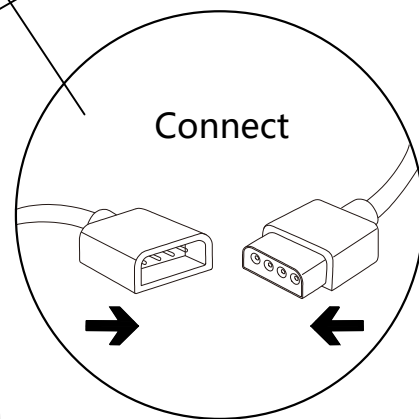
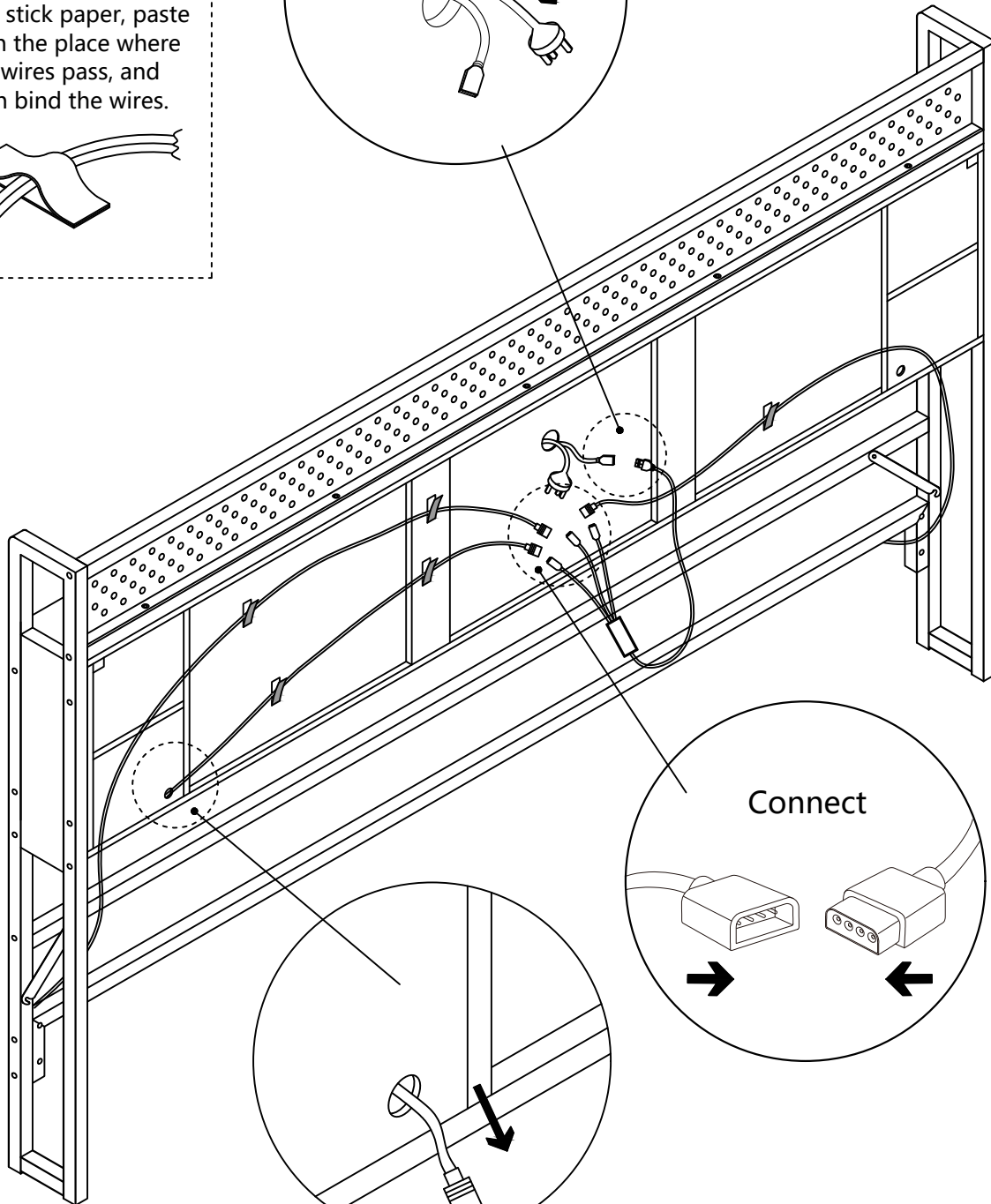
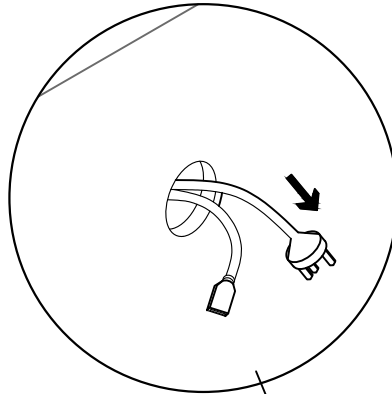
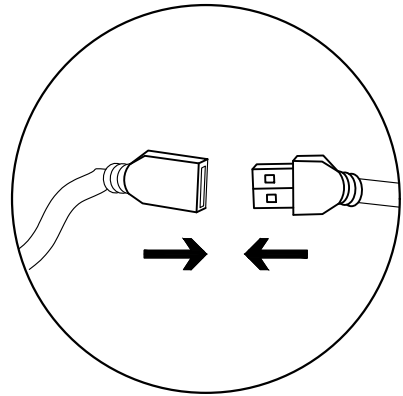

Just pull out the connector of the light strip from the back.