

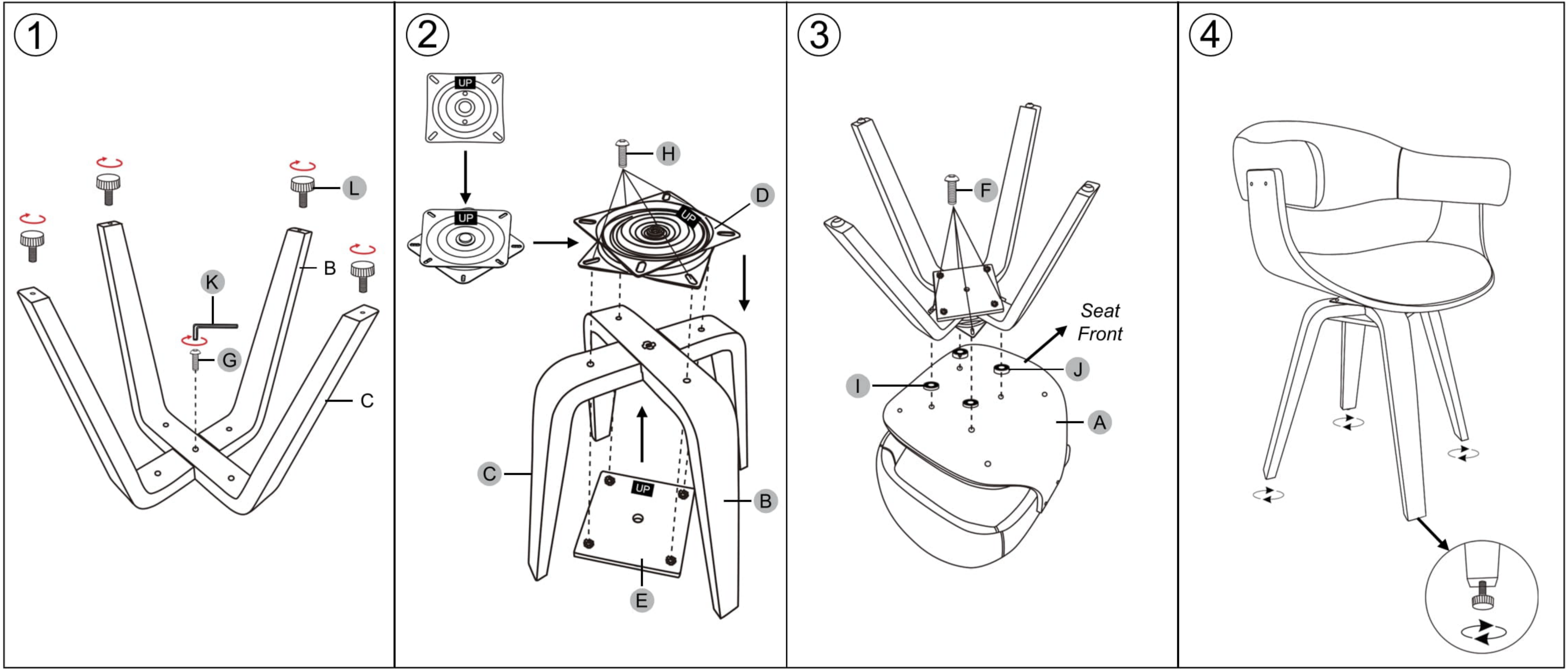





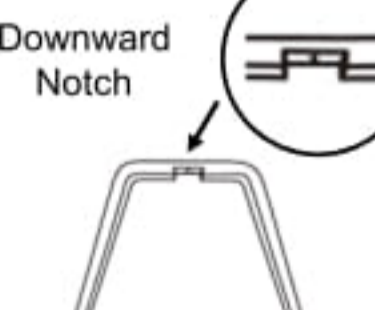
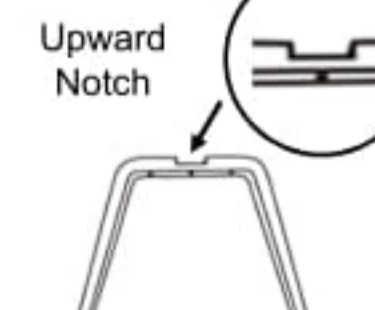
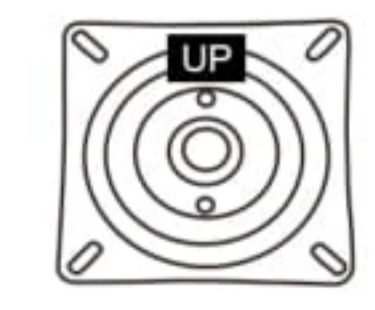

Assembly Tips:

- **STEP 2** - Ensure the base plate (#D) is positioned with "UP" label facing upward.
- **STEP 3** - Place the washers (#J) at the **FRONT** of the seat.
- **STEP 4** - Twist "Adjustable foot caps" as needed for uneven ground.
- **IMPORTANT** - **DO NOT** fully tighten the screws until all screws are properly placed into their holes.

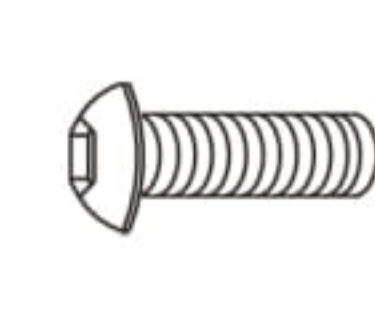
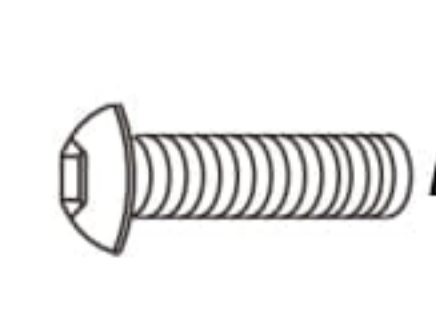
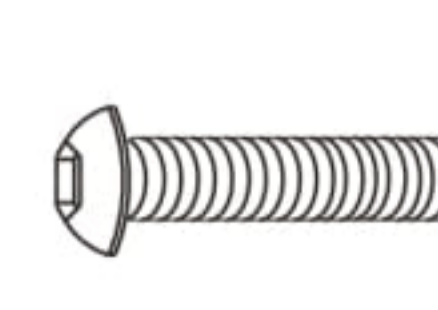

A  x1	B  x1	C  x1	D  #154 x1	E  x1	F  M6*20 mm x4
G  M6*30 mm x1	H  M6*40 mm x4	I  25*10*3 mm x2	J  25*10*5 mm x2	K  M6 x1	L  x4