

ASSEMBLY INSTRUCTIONS

Item Number **N604P336388N**
N604P336389N

This set comes in 2 boxes. If you do not receive a full 2 boxes, please contact our customer service.

Metal Bed:90*190cm

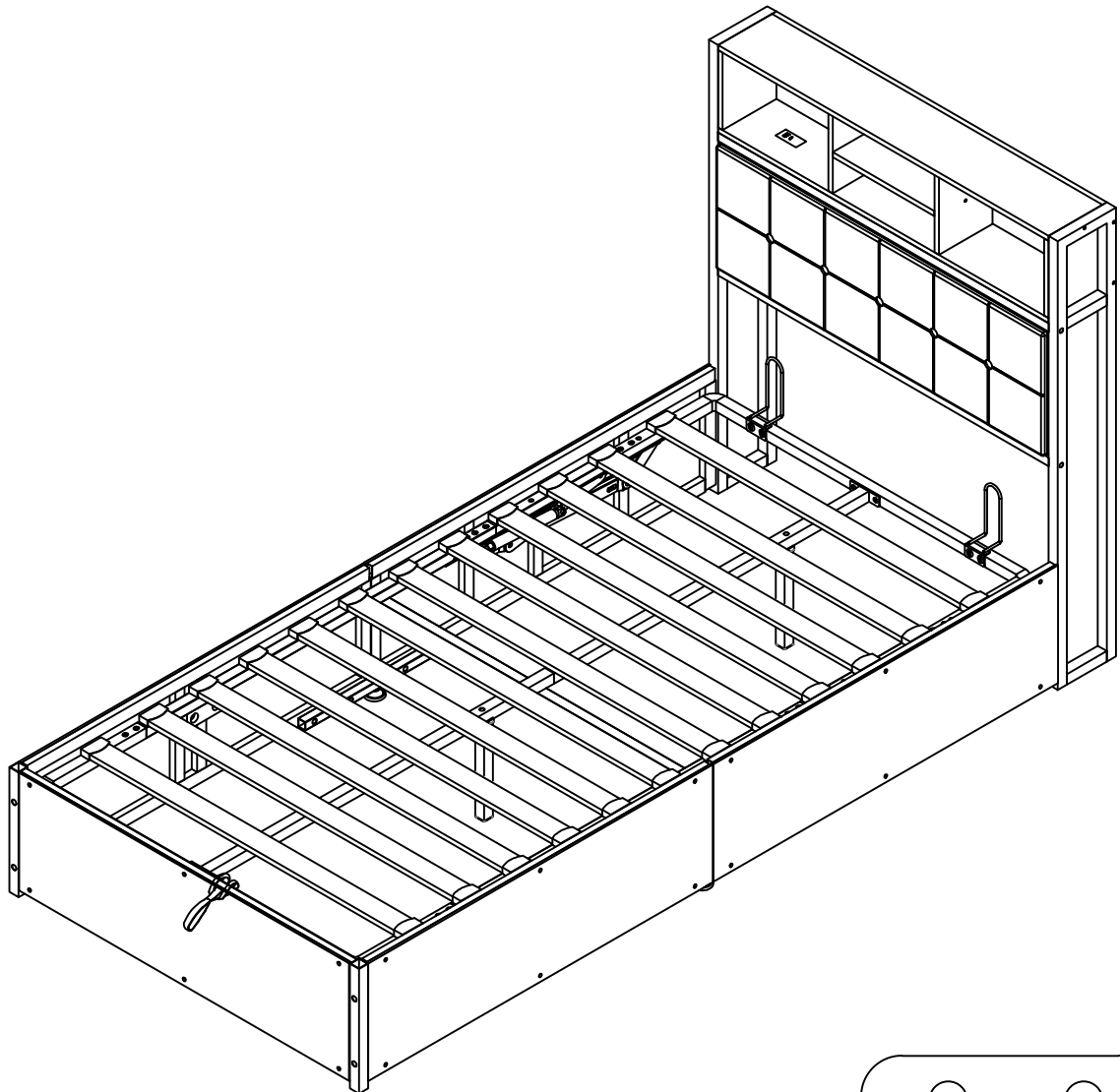

**UK
CA**

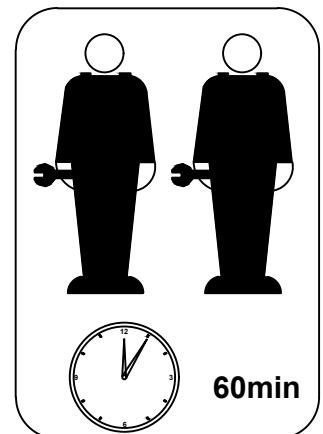
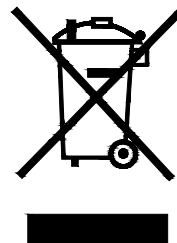

INSTRUCTIONS

IMPORTANT-READ CAREFULLY-RETAIN FOR FUTURE REFERENCE

- a) WARNING -Children can become trapped between the bed and the wall, the adjoining pieces of furniture (e.g. cupboards) and the like. To avoid risk of serious injury the distance between the safety barrier and the adjoining structure shall not exceed 90 mm or shall be more than 230 mm.
- b) WARNING-Do not use the bed if any structural part is broken or missing; Replacement parts are between requested from the manufacturer or the store.
- c) WARNING-Do not climb or wiggle on any non-designated structures.
- d) it is imperative to always follow the installation instructions and manufacturer's use.
- e) **The recommended size of the mattress to be used with the bed is 90cmx190cm, maximum thickness mattress:18-23cm.**
- f) It is necessary to ventilate the room in order to maintain a low level moisture and prevent mold growth in the bed and its periphery.
- g) Joining devices should always be tightened properly and regularly verified. Tighten if necessary.

ANLEITUNGEN

WICHTIG - SORGFÄLTIG LESEN - FÜR SPÄTERE VERWENDUNG

AUFBEWAHREN

- a) WARNUNG - Kinder können zwischen dem Bett und der Wand, den angrenzenden Möbelstücken (z. B. Schränken) und der Lücke eingeklemmt werden. Um die Gefahr schwerer Verletzungen zu vermeiden, darf der Abstand zwischen der Sicherheitsbarriere und der angrenzenden Struktur nicht mehr als 90 mm oder mehr als 230 mm betragen.
- b) WARNUNG-Das Bett darf nicht benutzt werden, wenn ein Bauteil gebrochen ist oder fehlt; Ersatzteile sind beim Hersteller oder im Geschäft anzufordern.
- c) WARNUNG - Klettern oder wackeln Sie nicht auf nicht dafür vorgesehenen Strukturen.
- d) Befolgen Sie unbedingt die Installationsanweisungen und die Gebrauchsanweisungen des Herstellers.
- e) **Die empfohlene Größe der Matratze für das Bett beträgt 90x190cm, maximale Dicke der Matratze: 18-23cm.**
- f) Es ist notwendig, den Raum zu lüften, um die Feuchtigkeit niedrig zu halten und Schimmelbildung im Bett und seiner Umgebung zu verhindern.
- g) Die Verbindungselemente sollten immer richtig angezogen sein und regelmäßig überprüft werden. Ziehen Sie sie gegebenenfalls nach.

English

IMPORTANT FOR GAS LIFT BEDS&MAINTAINCE

- Please place the mattress on top of the bed frame.
- Please do not pull on the strap handles.
- Please press heavily to release the compressed gas.
- Periodically check all screw & fixings to ensure they are secure.
- When moving your product, carefully lift into place.
- Wipe clean with a slightly damp cloth- please do not use abrasive chemicals or bleach.
- Do NOT allow children to operate the lift mechanism.
- Do NOT allow children near the lift base when operating the mechanism.
- Do NOT stand inside the bed or the internal storage base.
- Do NOT overload the internal storage base.
- DO NOT jump on the product or any of its parts.

Deutsch

WICHTIG FÜR GASLIFT-BETTEN&WARTUNG

- Bitte legen Sie die Matratze oben auf den Bettrahmen.
- Bitte ziehen Sie nicht an den Gurtgriffen.
- Bitte drücken Sie kräftig, um das komprimierte Gas freizusetzen.
- Überprüfen Sie regelmäßig alle Schrauben und Befestigungen, um sicherzustellen, dass sie sicher sind.
- Wenn Sie Ihr Produkt bewegen, heben Sie es vorsichtig an seinen Platz.
- Mit einem leicht feuchten Tuch abwischen - bitte keine scheuernden Chemikalien oder Bleichmittel verwenden.
- Erlauben Sie Kindern NICHT, den Hebemechanismus zu bedienen.
- Lassen Sie Kinder NICHT in die Nähe des Liftsockels, wenn Sie den Mechanismus bedienen.
- Stellen Sie sich NICHT in das Bett oder in die Innenablage.
- Überlasten Sie den internen Liftsockel NICHT.
- Springen Sie NICHT auf das Produkt oder eines seiner Teile.

Français

IMPORTANT POUR LES LITS À RELEVAGE DE GAZ&MAINTENANCE

- Veuillez placer le matelas sur le dessus du cadre de lit.
- Ne tirez pas sur les poignées de la sangle.
- Appuyez fortement pour libérer le gaz comprimé.
- Vérifiez régulièrement que toutes les vis et fixations sont bien en place.
- Lorsque vous déplacez votre produit, soulevez-le avec précaution pour le mettre en place.
- Nettoyez avec un chiffon légèrement humide - n'utilisez pas de produits chimiques abrasifs ou d'eau de Javel.
- Ne laissez pas les enfants utiliser le mécanisme de levage.
- Ne laissez pas les enfants s'approcher de la base de levage lorsqu'ils actionnent le mécanisme.
- Ne vous tenez PAS à l'intérieur du lit ou de la base de stockage interne.
- Ne surchargez pas la base de stockage interne.
- Ne pas sauter sur le produit ou l'une de ses parties.

- Posizionare il materasso sopra la struttura del letto.
- Non tirare le maniglie della cinghia.
- Premere con forza per rilasciare il gas compresso.
- Controllare periodicamente tutte le viti e i fissaggi per assicurarsi che siano saldi.
- Quando si sposta il prodotto, sollevarlo con cautela.
- Pulire con un panno leggermente umido, senza usare prodotti chimici abrasivi o candeggina.
- NON permettere ai bambini di azionare il meccanismo di sollevamento.
- NON permettere ai bambini di avvicinarsi alla base di sollevamento quando si aziona il meccanismo.
- NON sostare all'interno del letto o della base di contenimento interna.
- NON sovraccaricare la base di contenimento interna.
- NON saltare sul prodotto o sulle sue parti.

- Coloque el colchón sobre el somier.
- No tire de las asas de la correa.
- Presione con fuerza para liberar el gas comprimido.
- Compruebe periódicamente que todos los tornillos y fijaciones estén bien sujetos.
- Al mover el producto, levántelo con cuidado para colocarlo en su sitio.
- Limpie con un paño ligeramente humedecido; no utilice productos químicos abrasivos ni lejía.
- NO permita que los niños accionen el mecanismo de elevación.
- NO permita que los niños se acerquen a la base elevadora cuando accionen el mecanismo.
- NO se ponga de pie dentro de la cama o de la base de almacenamiento interna.
- NO sobrecargue el somier.
- NO salte sobre el producto ni sobre ninguna de sus piezas.

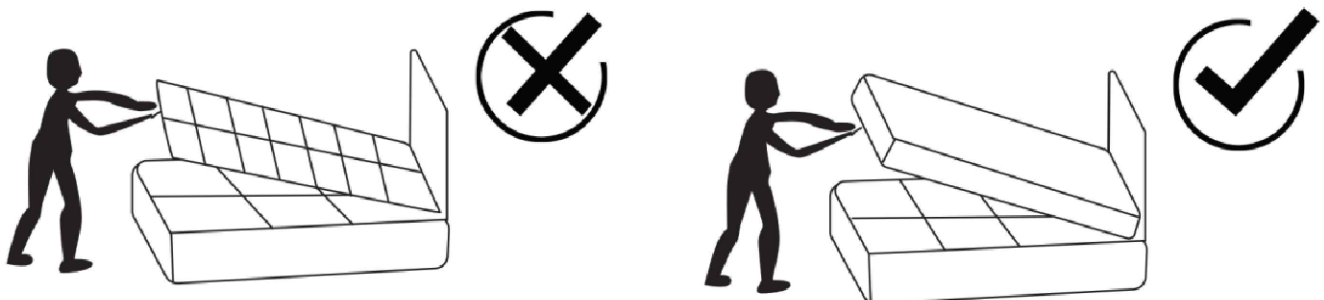

Part list N604P336388N

1

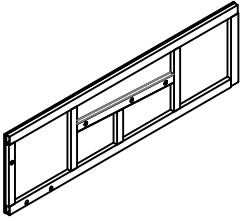

1PC

2

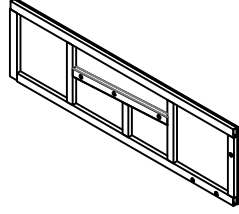

1PC

3

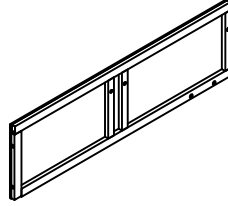

1PC

4

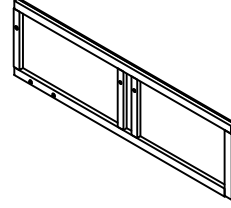

1PC

6

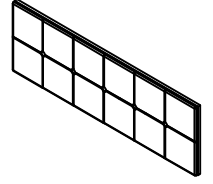

1PC

7

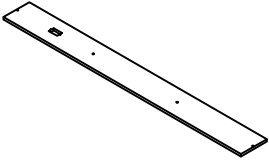

1PC

13

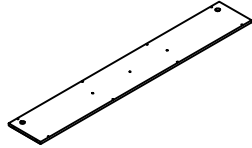

1PC

14

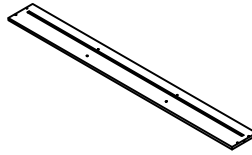

1PC

15

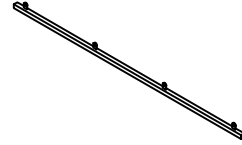

1PC

16

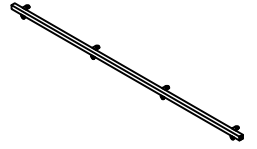

1PC

17

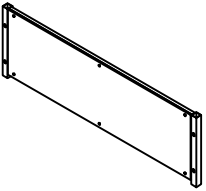

1PC

18

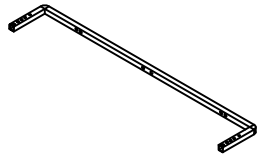

1PC

19

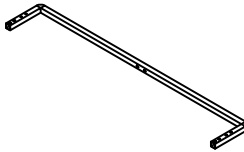

1PC

21

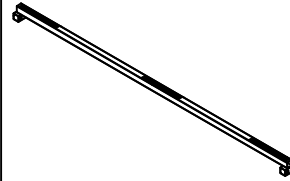





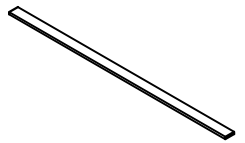

1PC

39

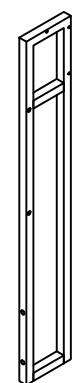
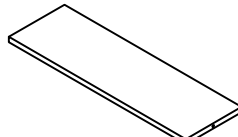
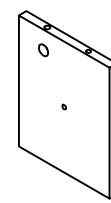
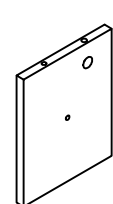
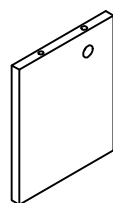
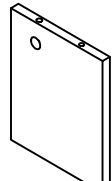
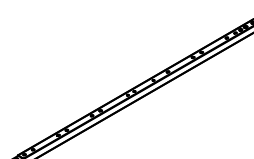
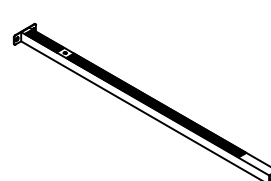
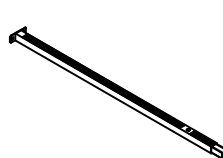
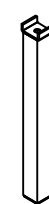
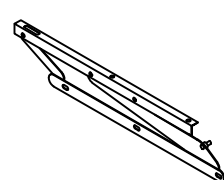
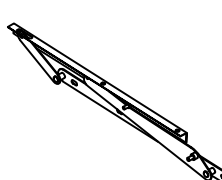
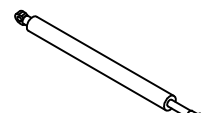
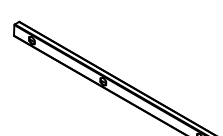
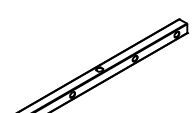

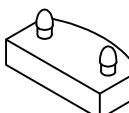
12PCS

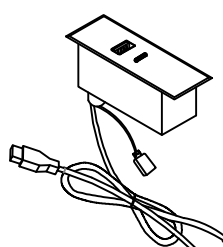
Part list N604P336389N

<p>5</p>  <p>2PCS</p>	<p>8</p>  <p>1PC</p>	<p>9</p>  <p>1PC</p>	<p>10</p>  <p>1PC</p>	<p>11</p>  <p>1PC</p>
<p>12</p>  <p>1PC</p>	<p>20</p>  <p>2PCS</p>	<p>22</p>  <p>1PC</p>	<p>23</p>  <p>1PC</p>	<p>24</p>  <p>2PCS</p>
<p>25</p>  <p>1PC</p>	<p>26</p>  <p>1PC</p>	<p>27</p>  <p>2PCS</p>	<p>28</p>  <p>2PCS</p>	<p>29</p>  <p>2PCS</p>
<p>30</p>  <p>2PCS</p>	<p>31</p>  <p>24PCS</p>	<p>32</p>  <p>1PC</p>	<p>33</p>  <p>1PC</p>	<p>34</p>  <p>1PC</p>

35

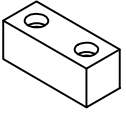

4PCS

36

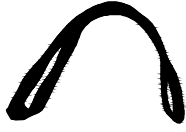

1PC

37

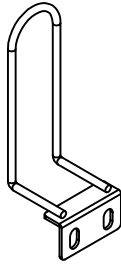





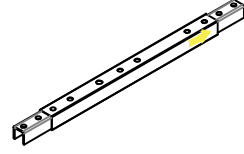

2PCS

38

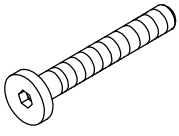
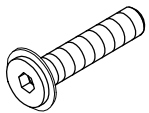
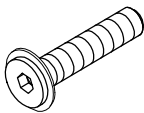
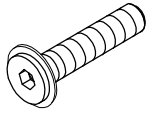

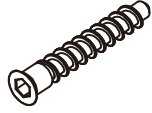
2PCS

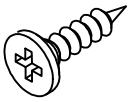
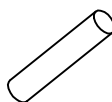
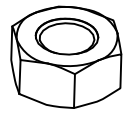
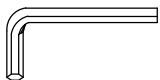
Hardware list N604P336389N

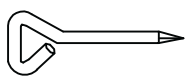
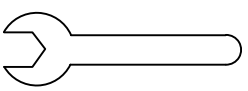
<p>X1</p>  <p>M8*45mm 6PCS</p>	<p>X2</p>  <p>M8*45mm 16PCS</p>	<p>X3</p>  <p>M8*35mm 18PCS</p>	<p>X4</p>  <p>M8*30mm 6PCS</p>
<p>X5</p>  <p>M8*16mm 22PCS</p>	<p>X6</p>  <p>M6*12mm 12PCS</p>	<p>X7</p>  <p>M5*50mm 23PCS</p>	<p>X8</p>  <p>M6*35mm 4PCS</p>
<p>X9</p>  <p>Ø15*Ø9.5 4PCS</p>	<p>X10</p>  <p>M3*12mm 2PCS</p>	<p>X11</p>  <p>Ø6*30mm 4PCS</p>	<p>X12</p>  <p>M8 10PCS</p>
<p>Z1</p>  <p>M8 Spanner 1PC</p>	<p>Z2</p>  <p>M6 Spanner 1PC</p>	<p>Z3</p>  <p>M5 Spanner 1PC</p>	<p>Z4</p>  <p>M3 Spanner 1PC</p>
<p>Z5</p>  <p>M8 Spanner 1PC</p>			

Detail View

NOTE:Please do not completely tighten all the hardware until the entire assembly is complete!

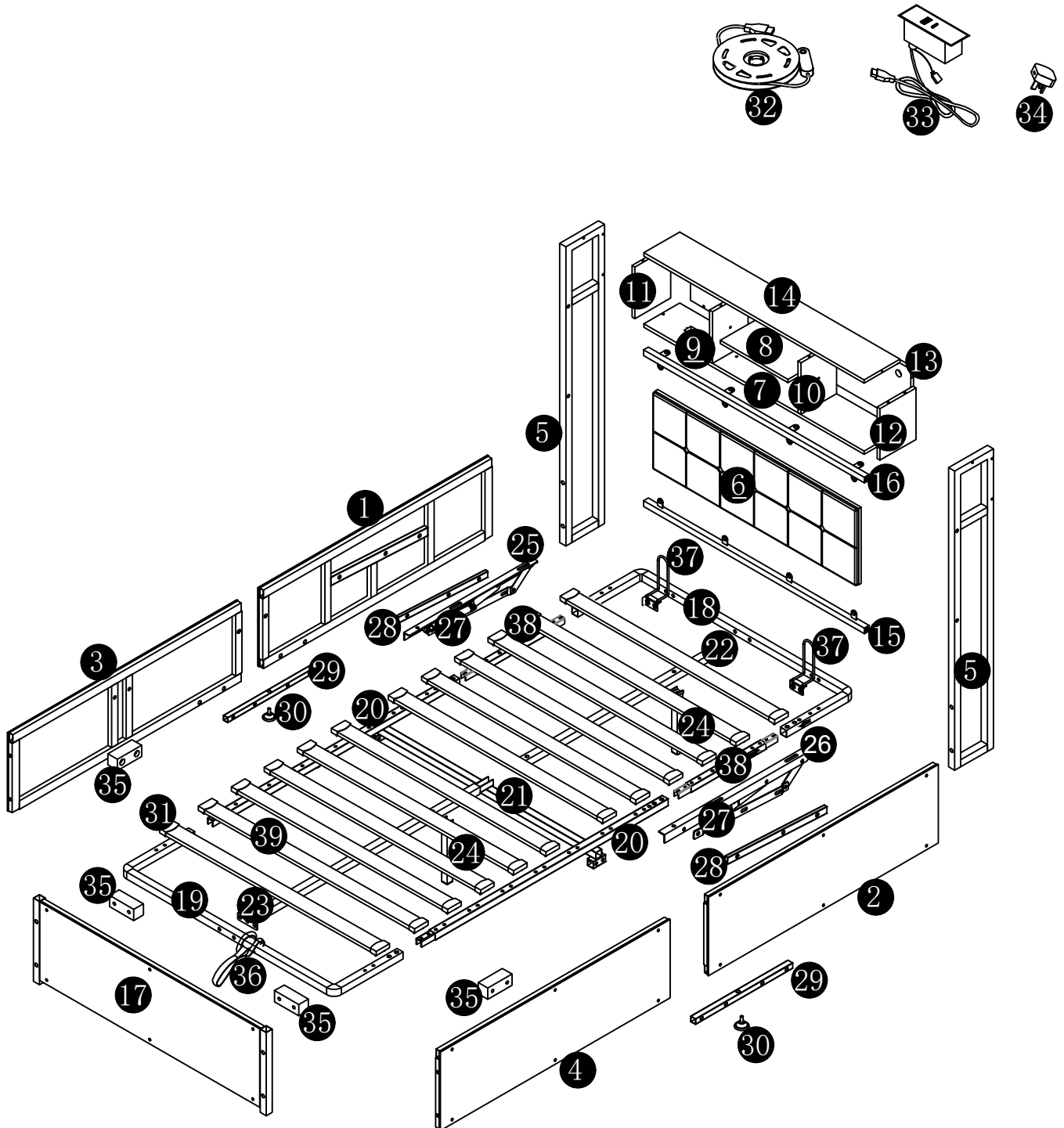

step1

X7



2PCS

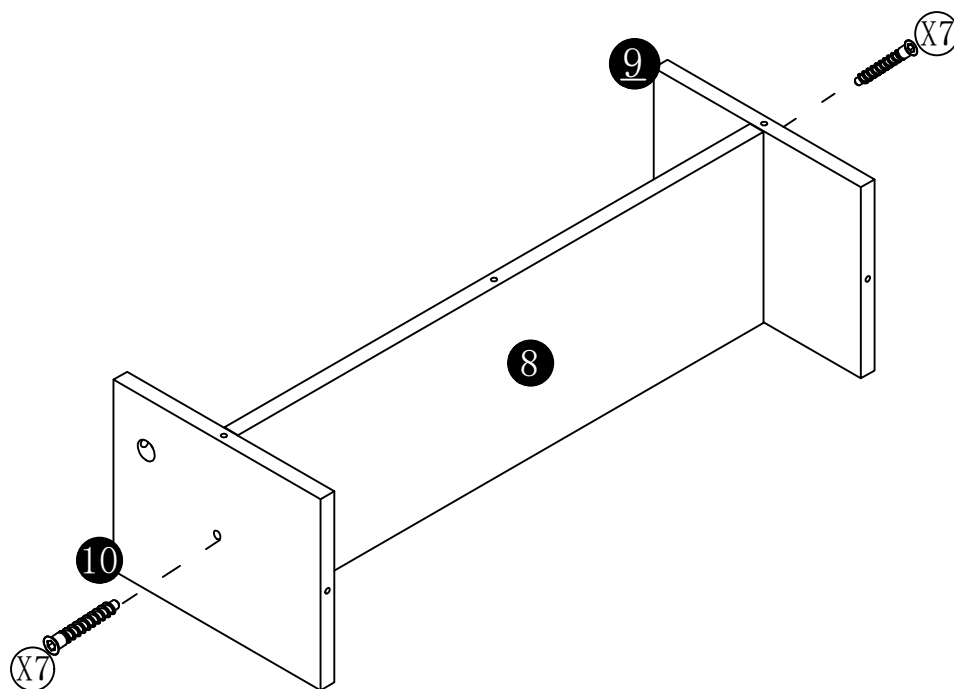

step2

X6



4PCS

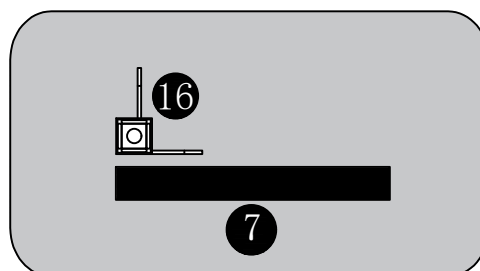
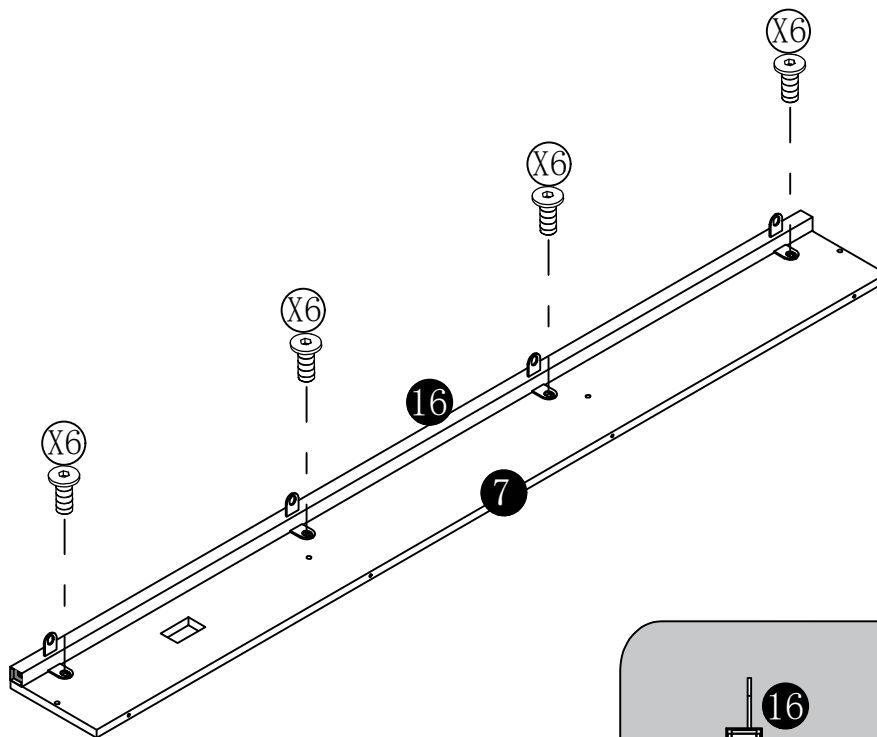

step3

X7



2PCS

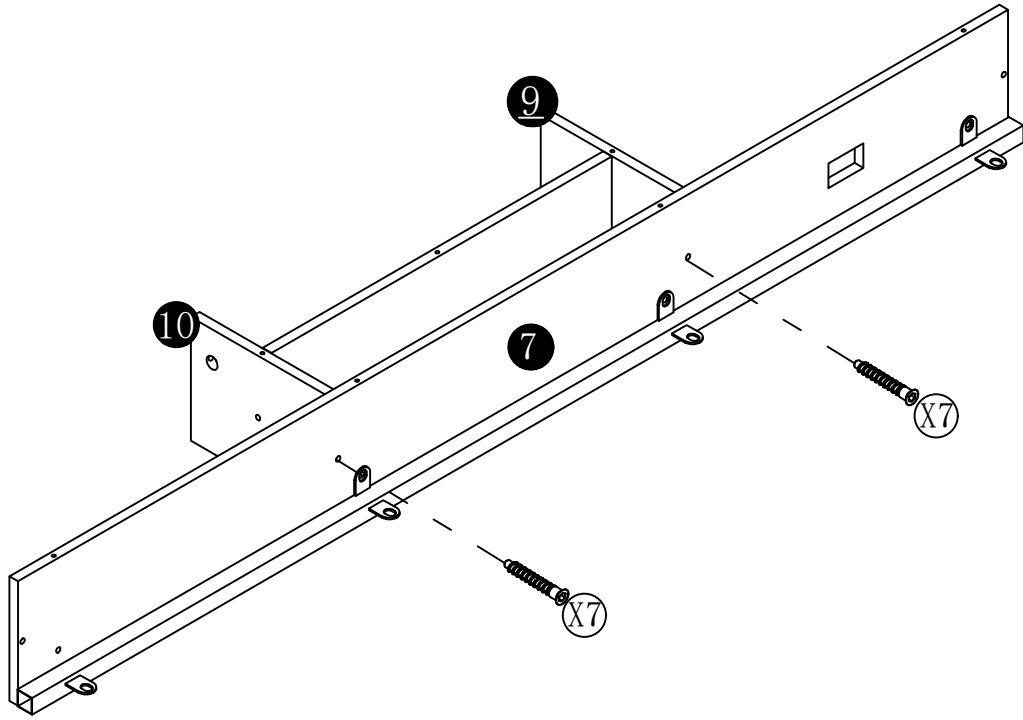

step4

X7



2PCS

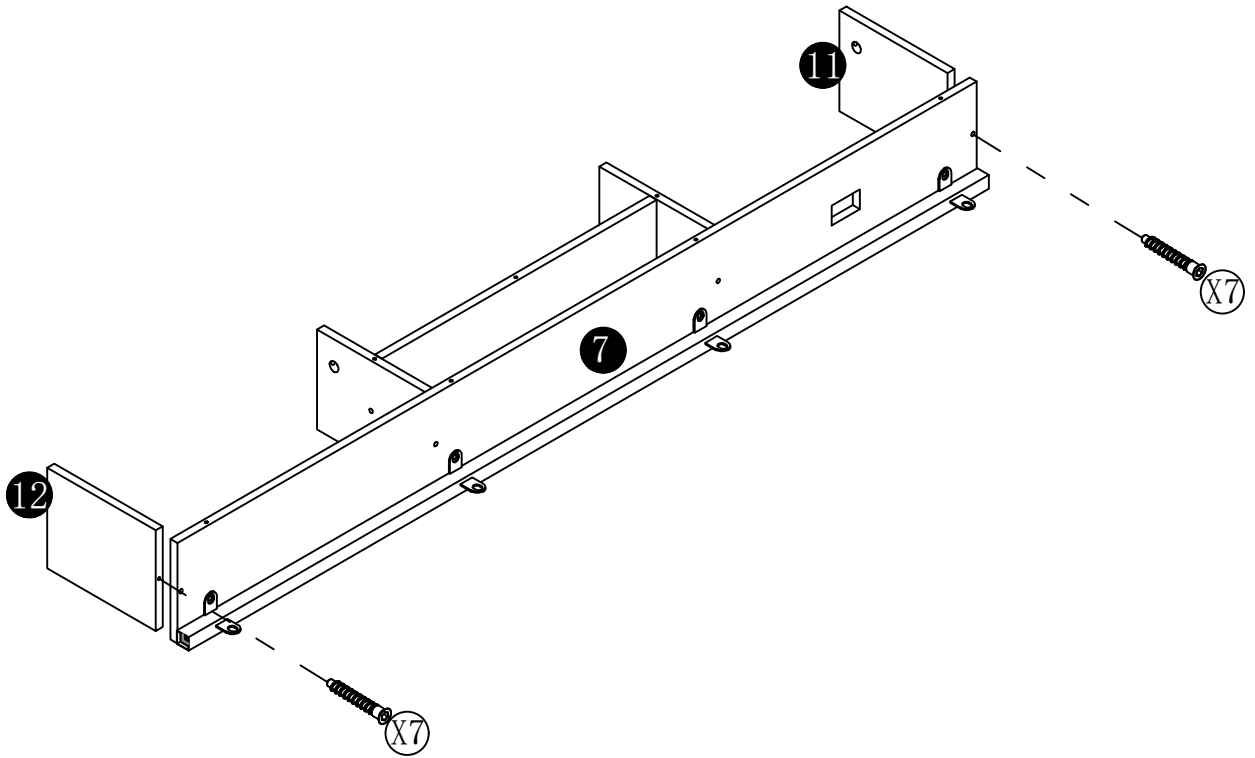

step5

X7



7PCS

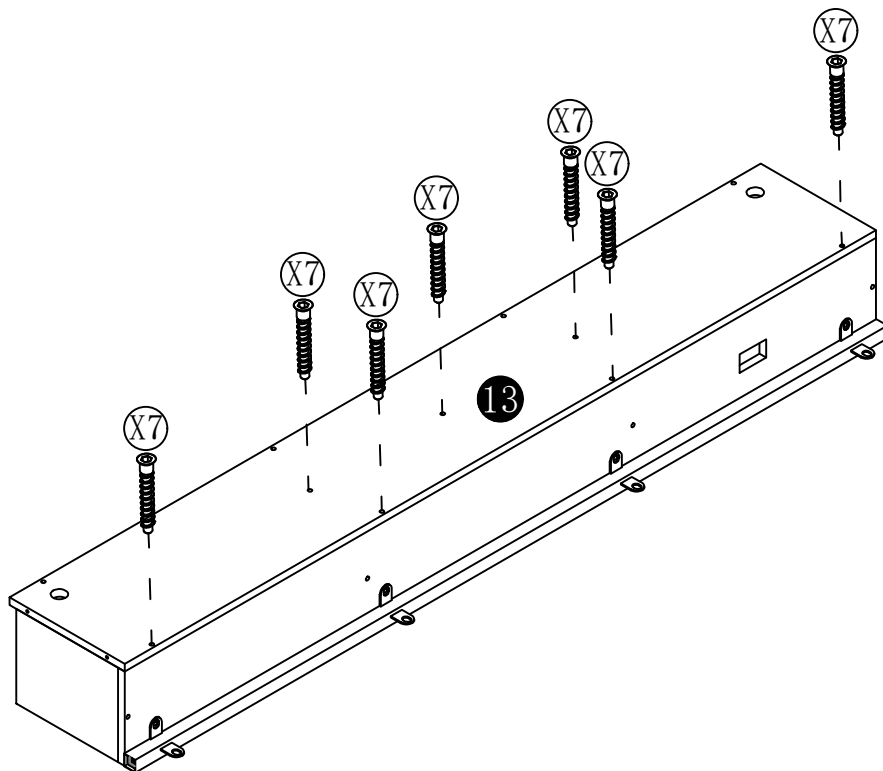

step6

X1



2PCS

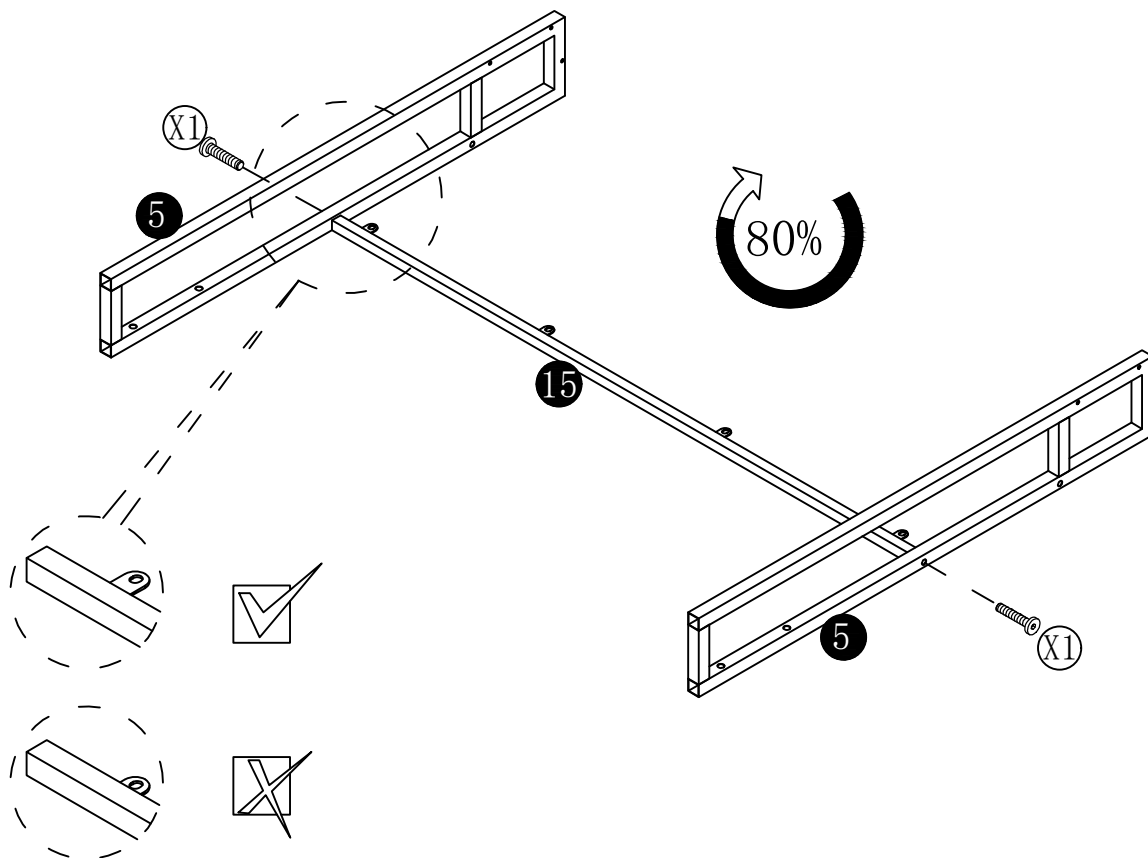

step7

X1	X7
2PCS	4PCS

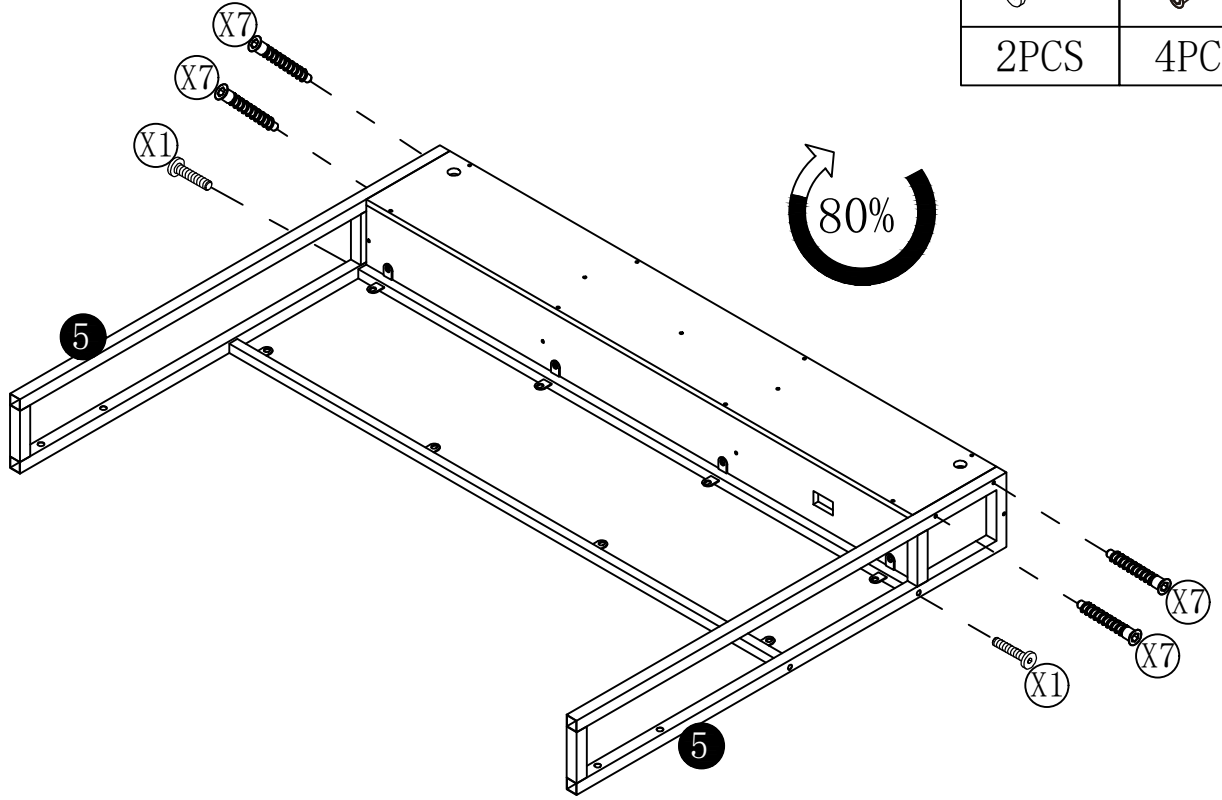

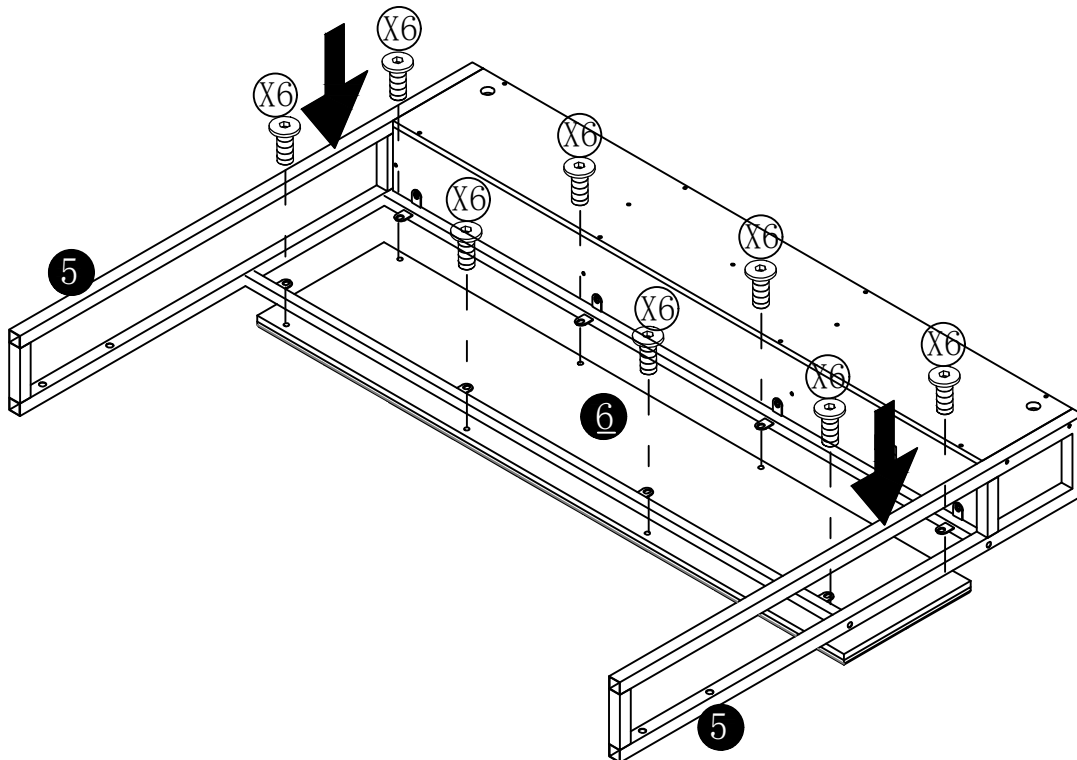

step8

X6
8PCS



step9

X10	X11
	
2PCS	4PCS

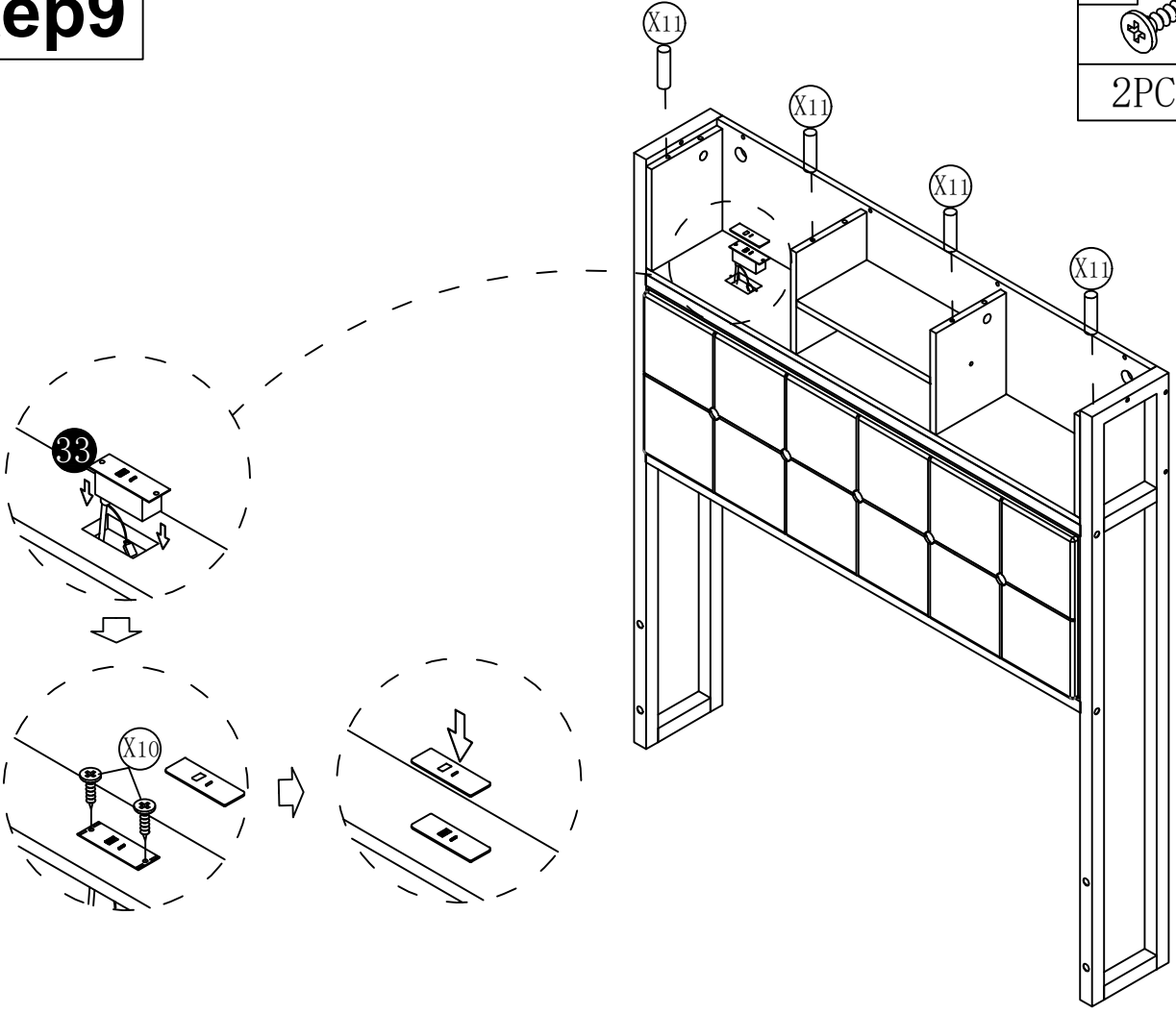

step10

X8

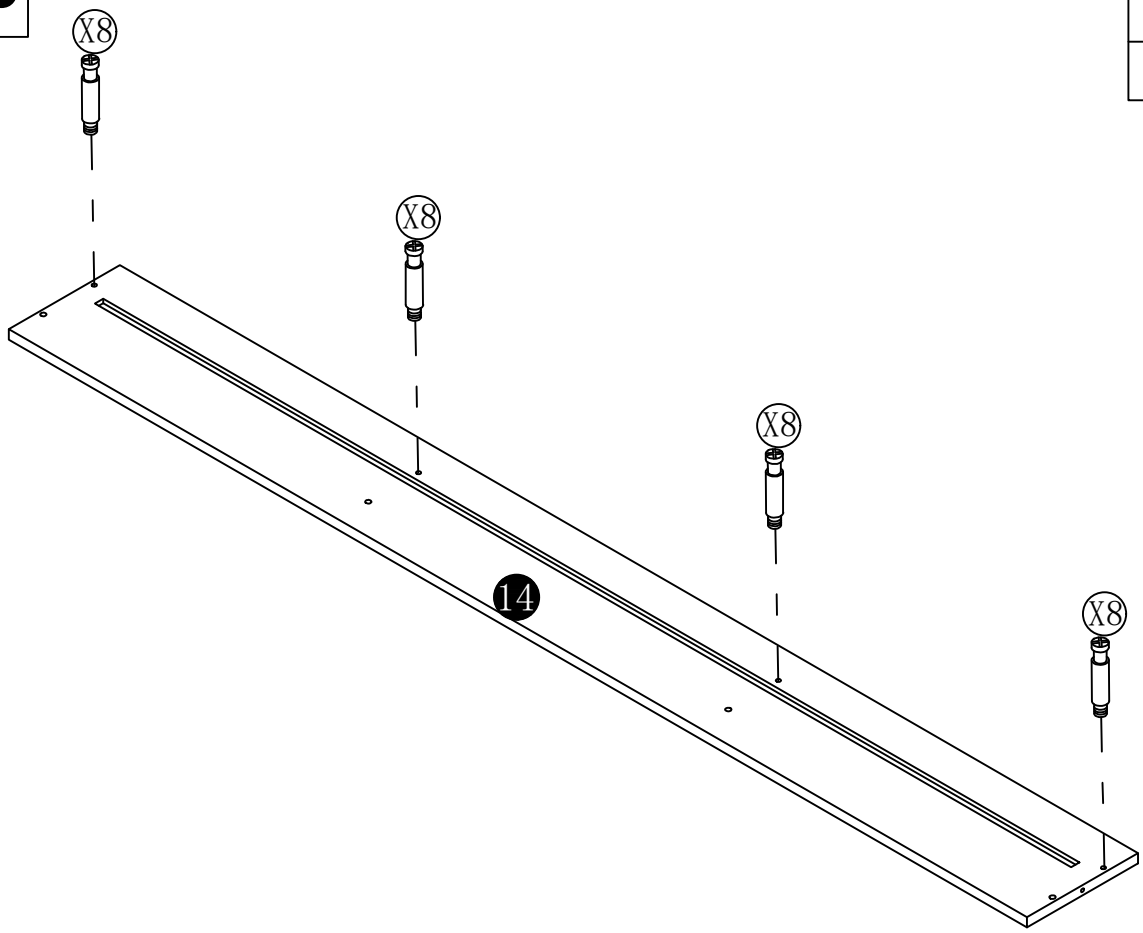
4PCS

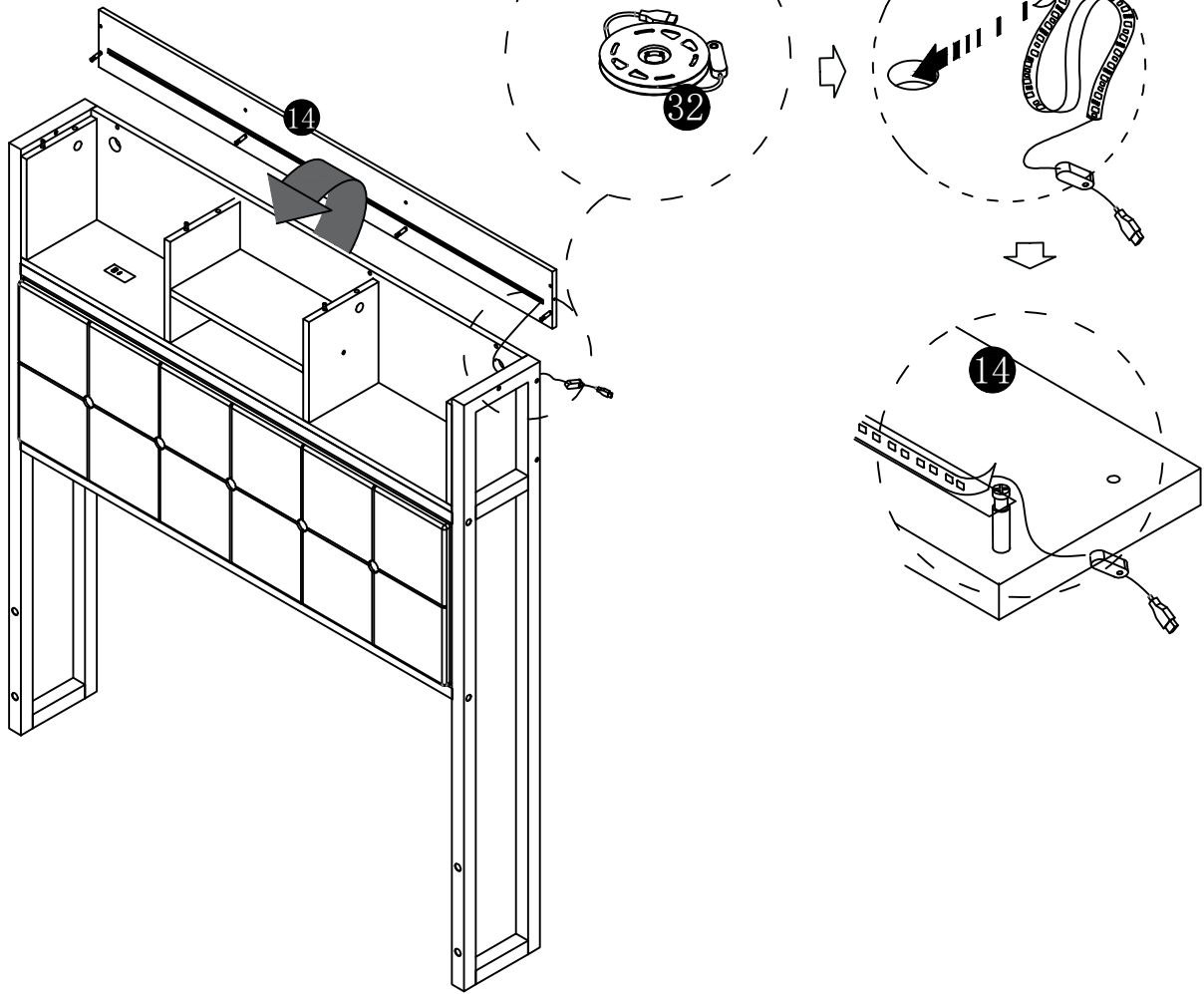

step11

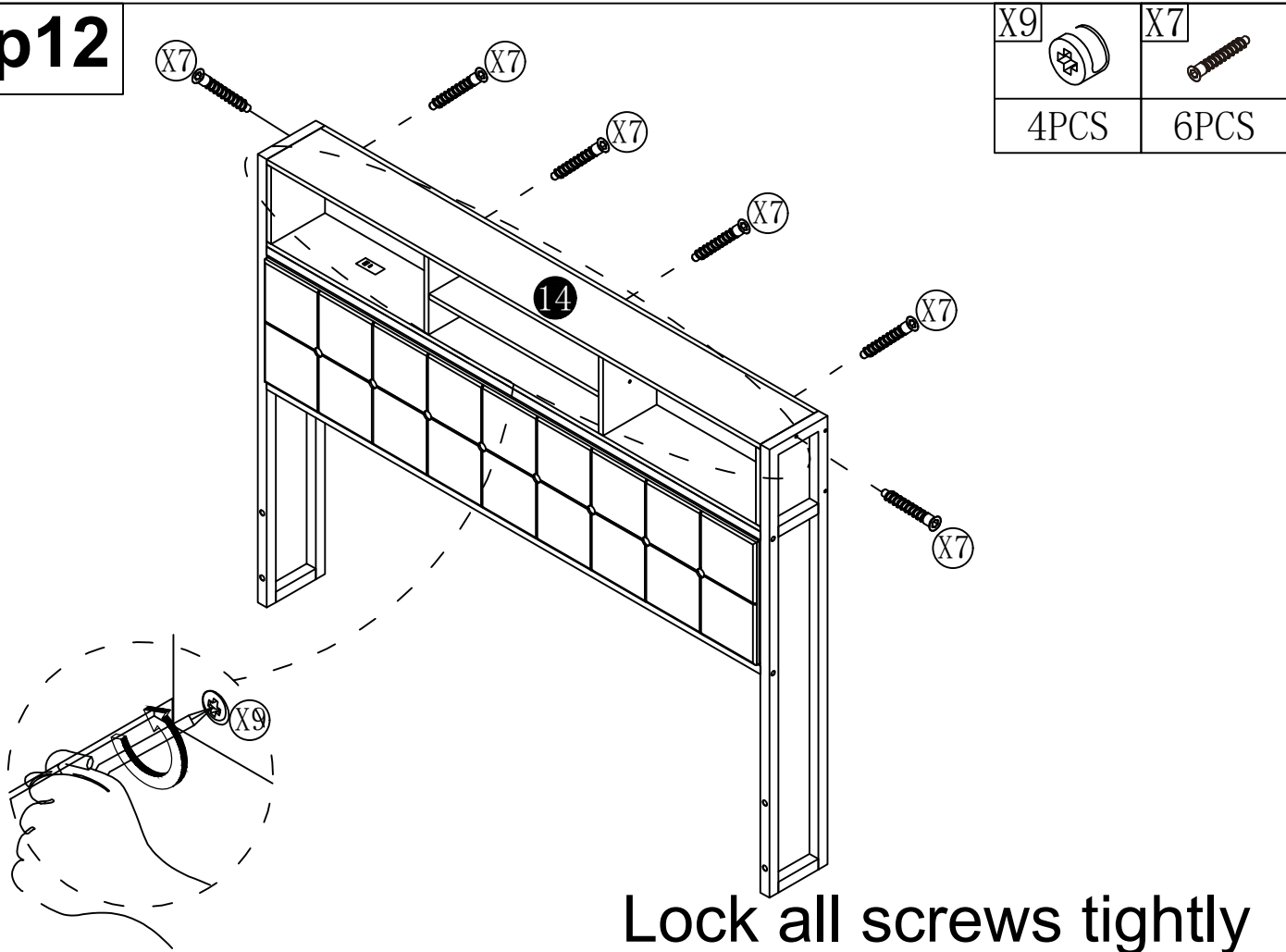

step12



step13

X3



8PCS

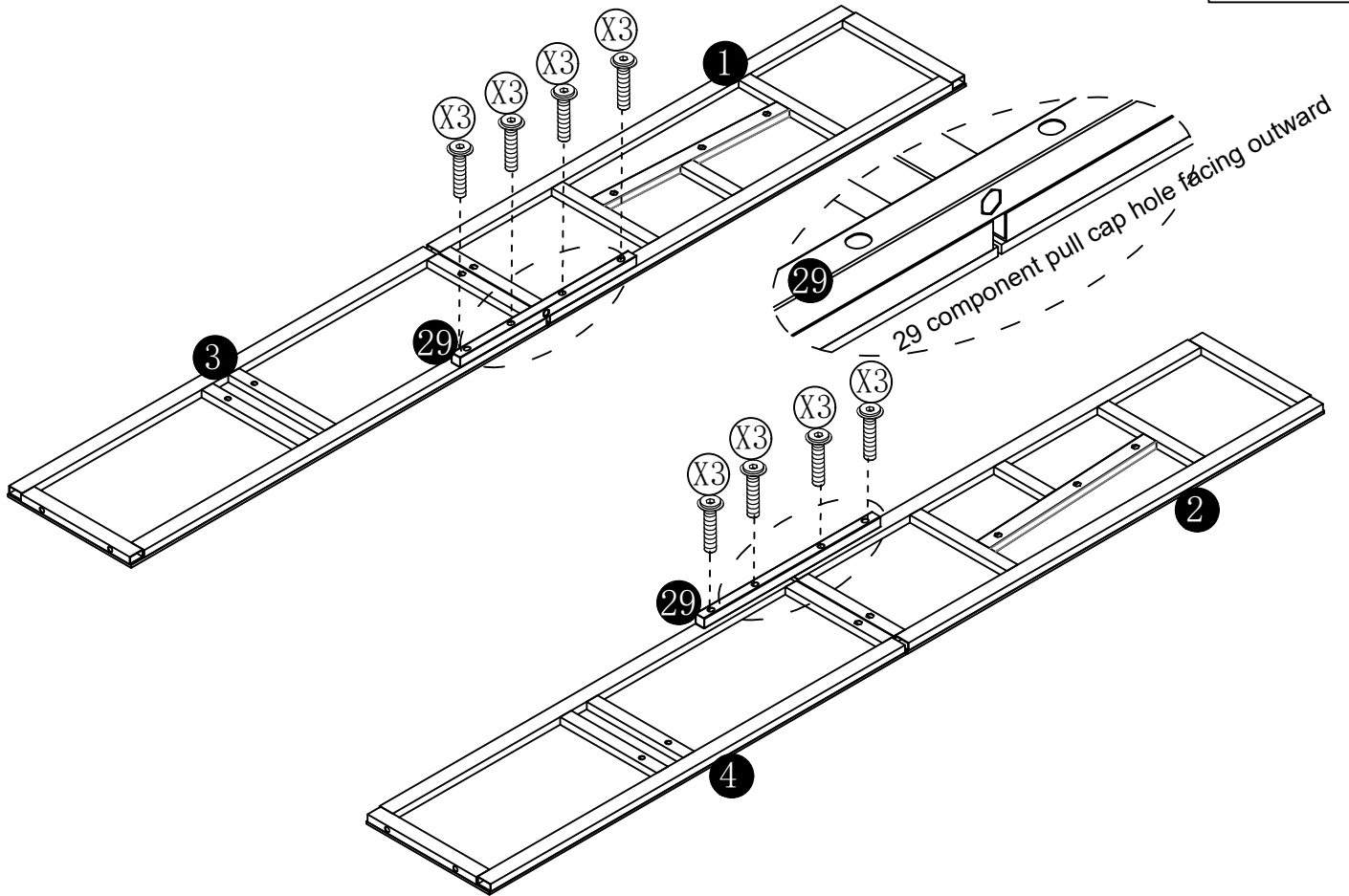

step14

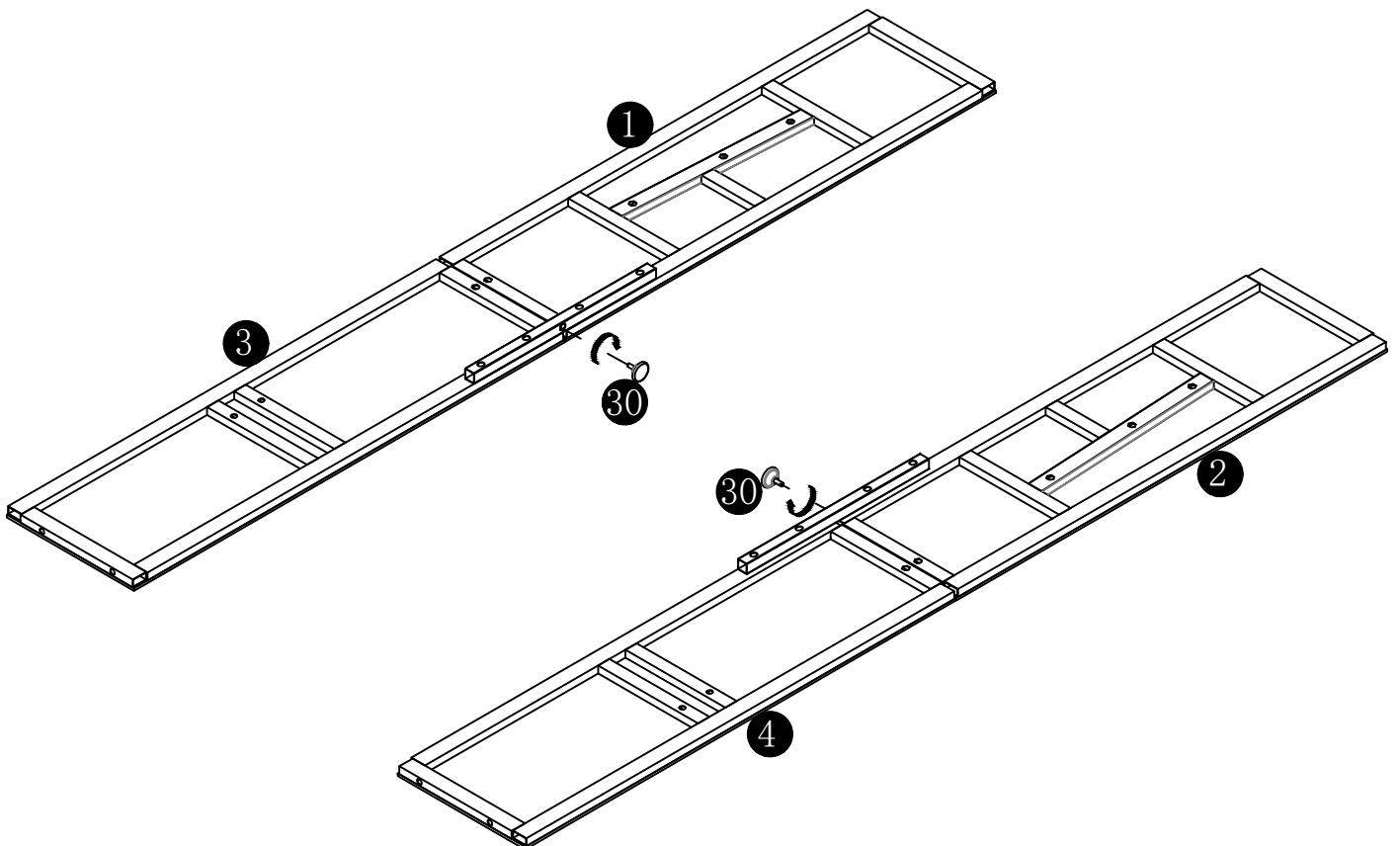

step15

X2



4PCS

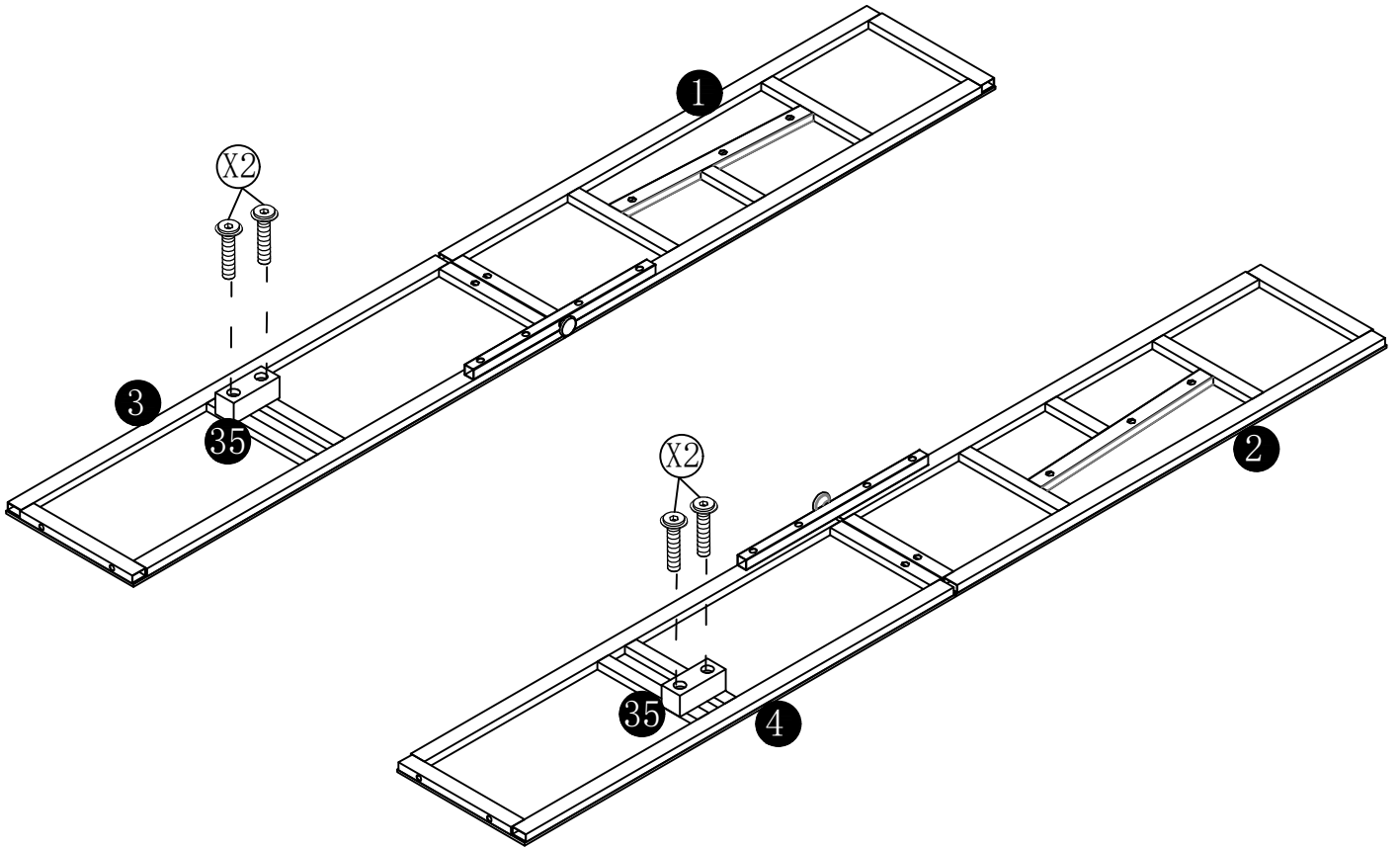

step16

X4



6PCS

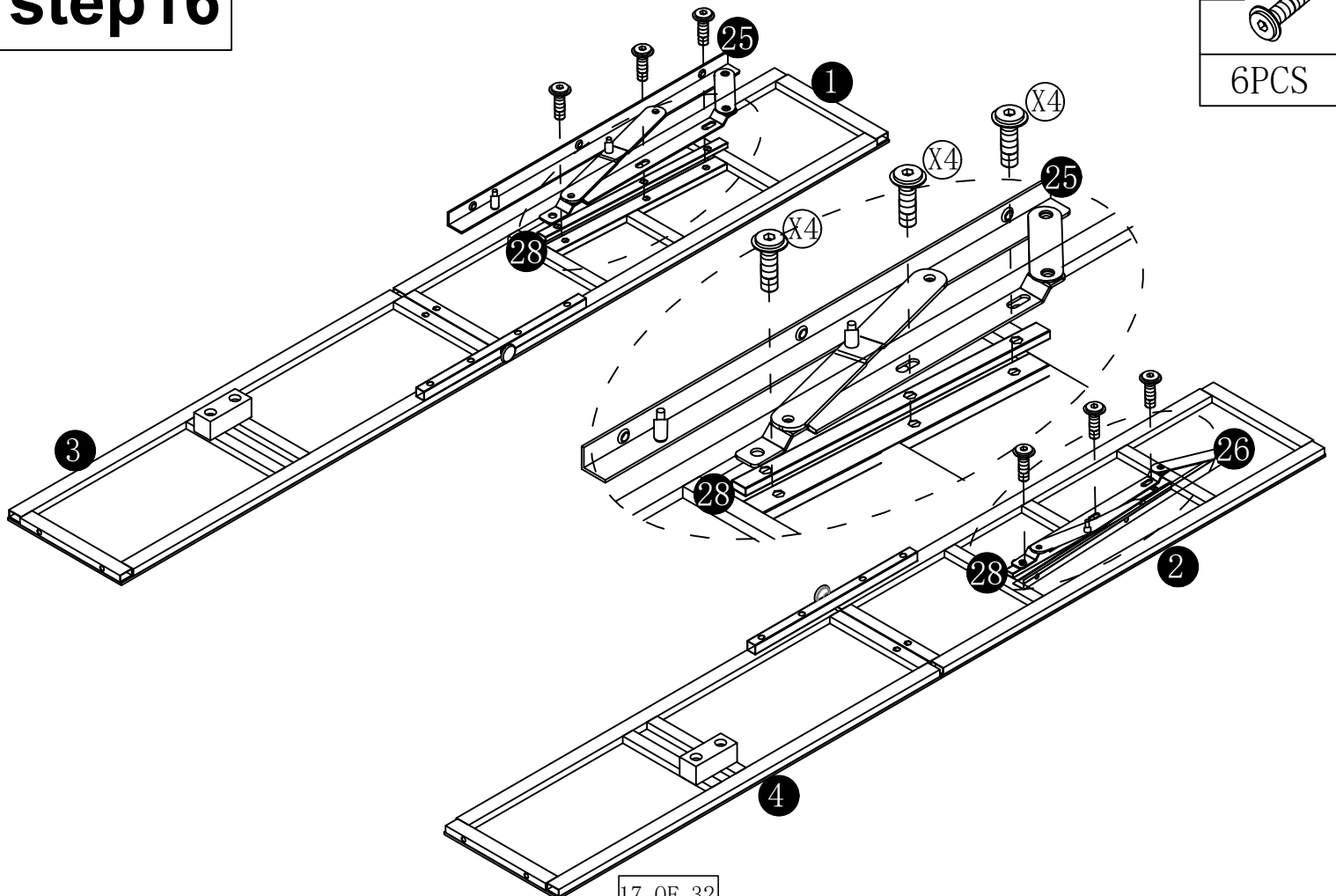

step19

X3



4PCS

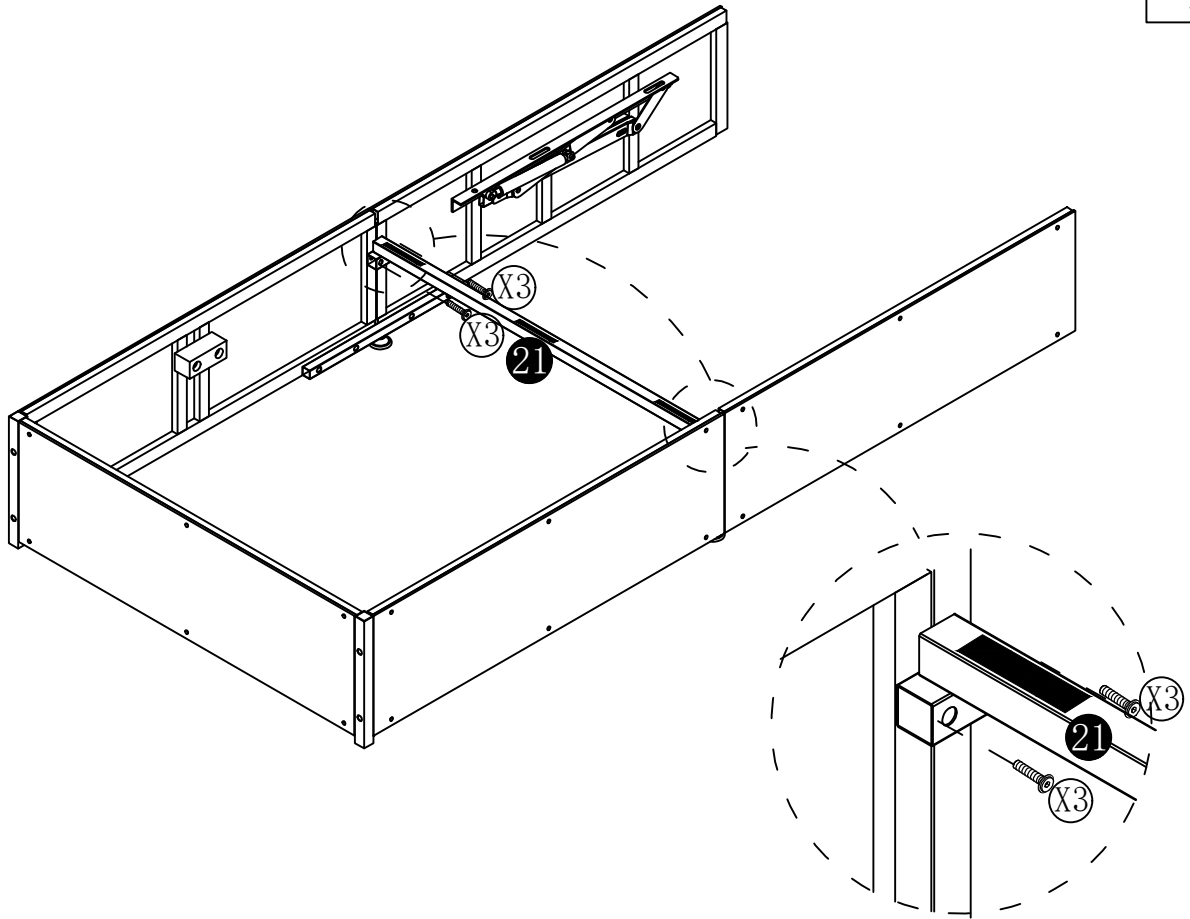

step20

X2



4PCS

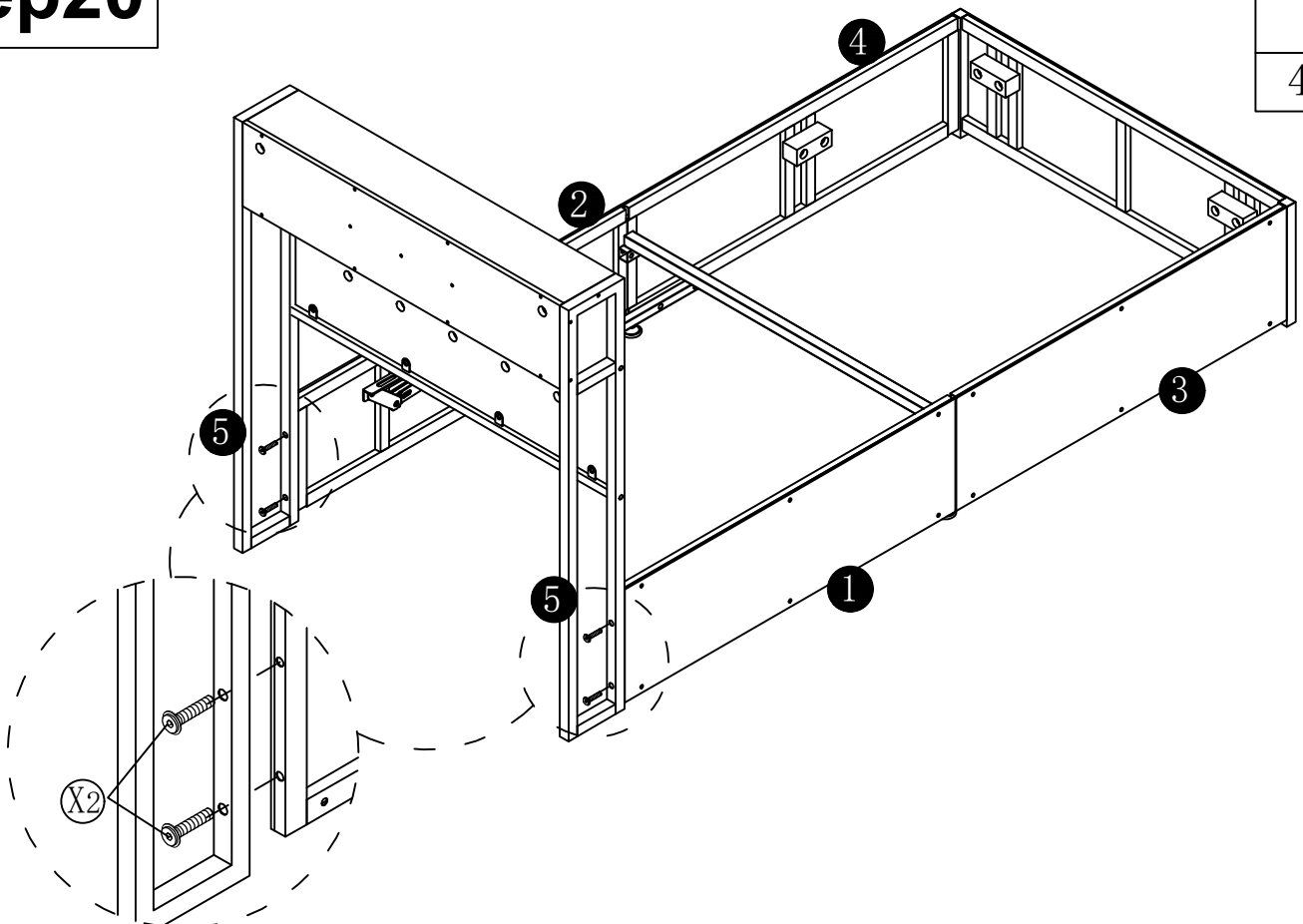

step21

X5



2PCS

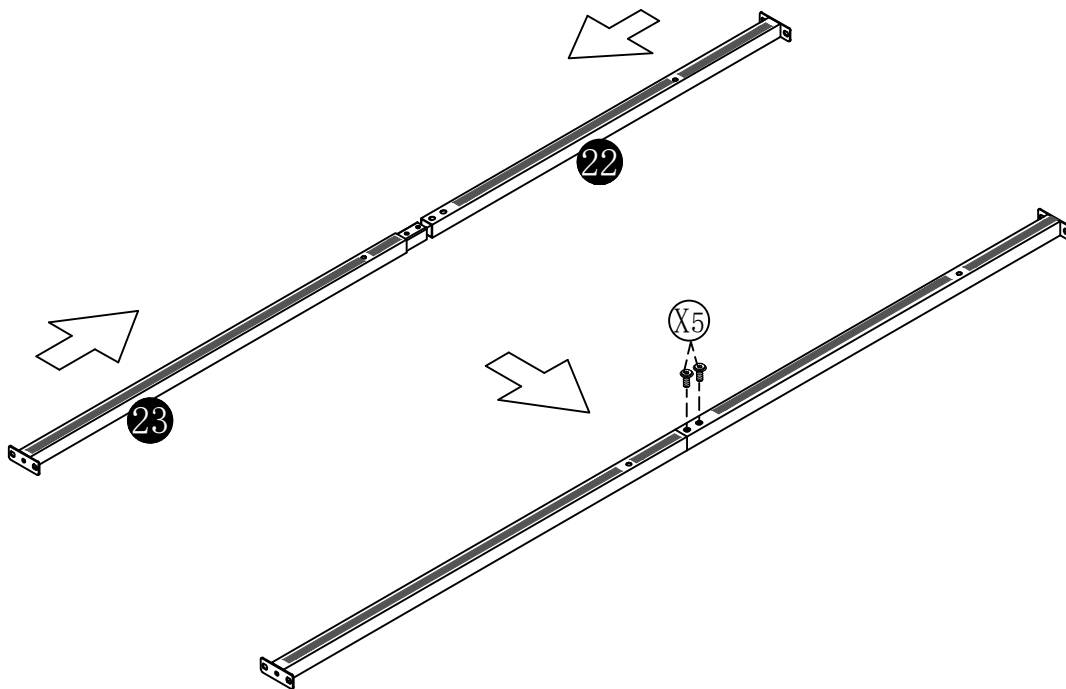

step22

X5



4PCS

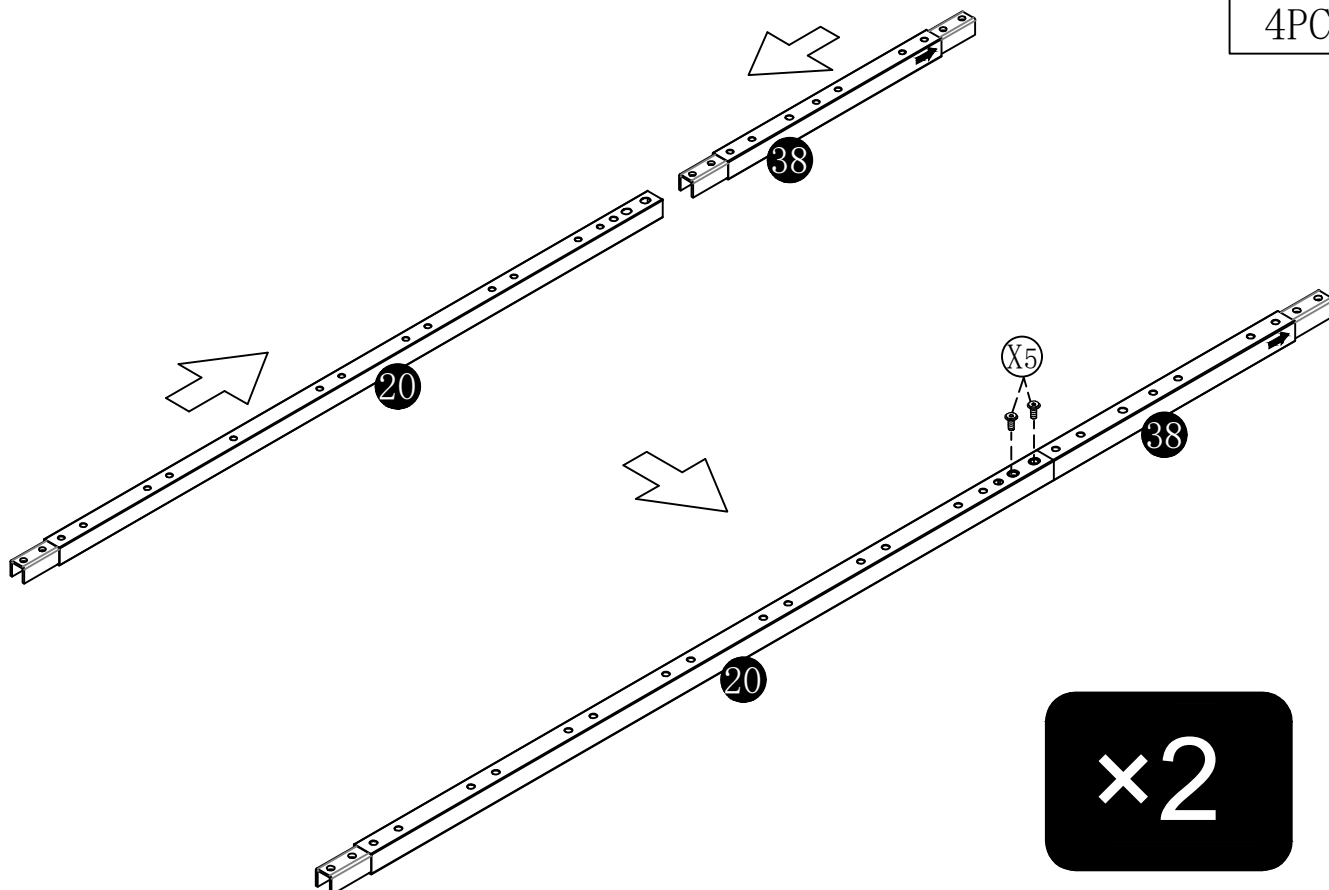

step23

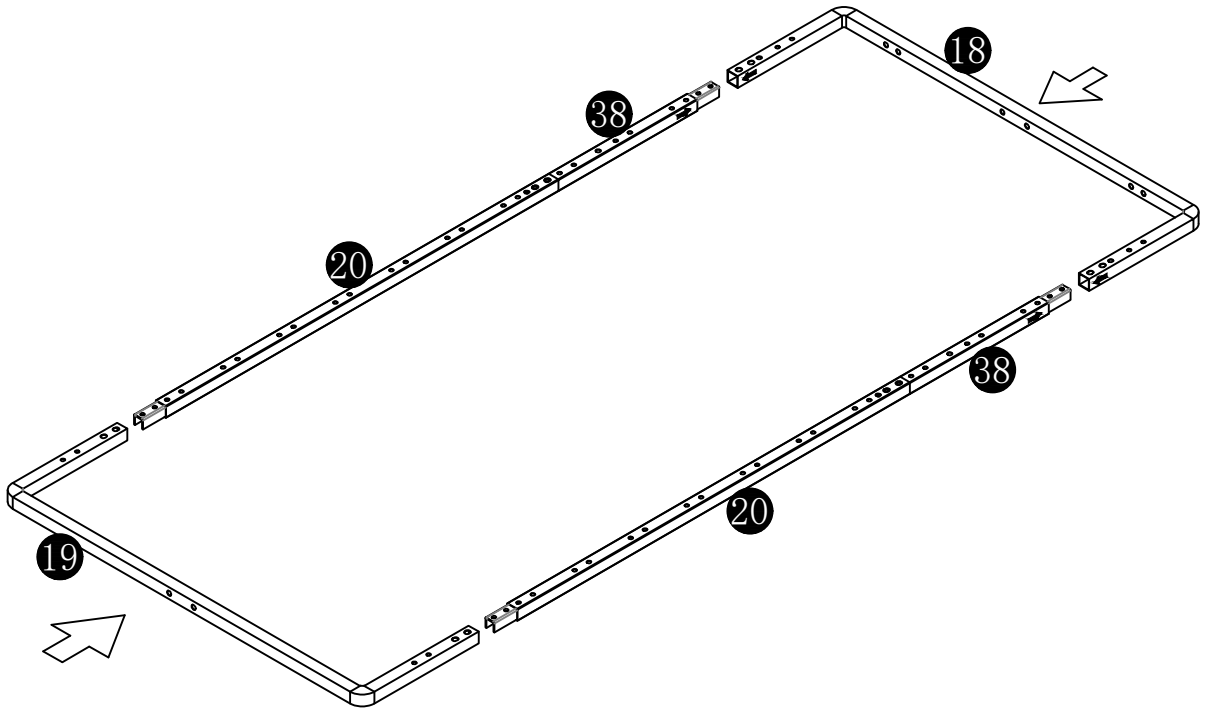

step24

X5

8PCS

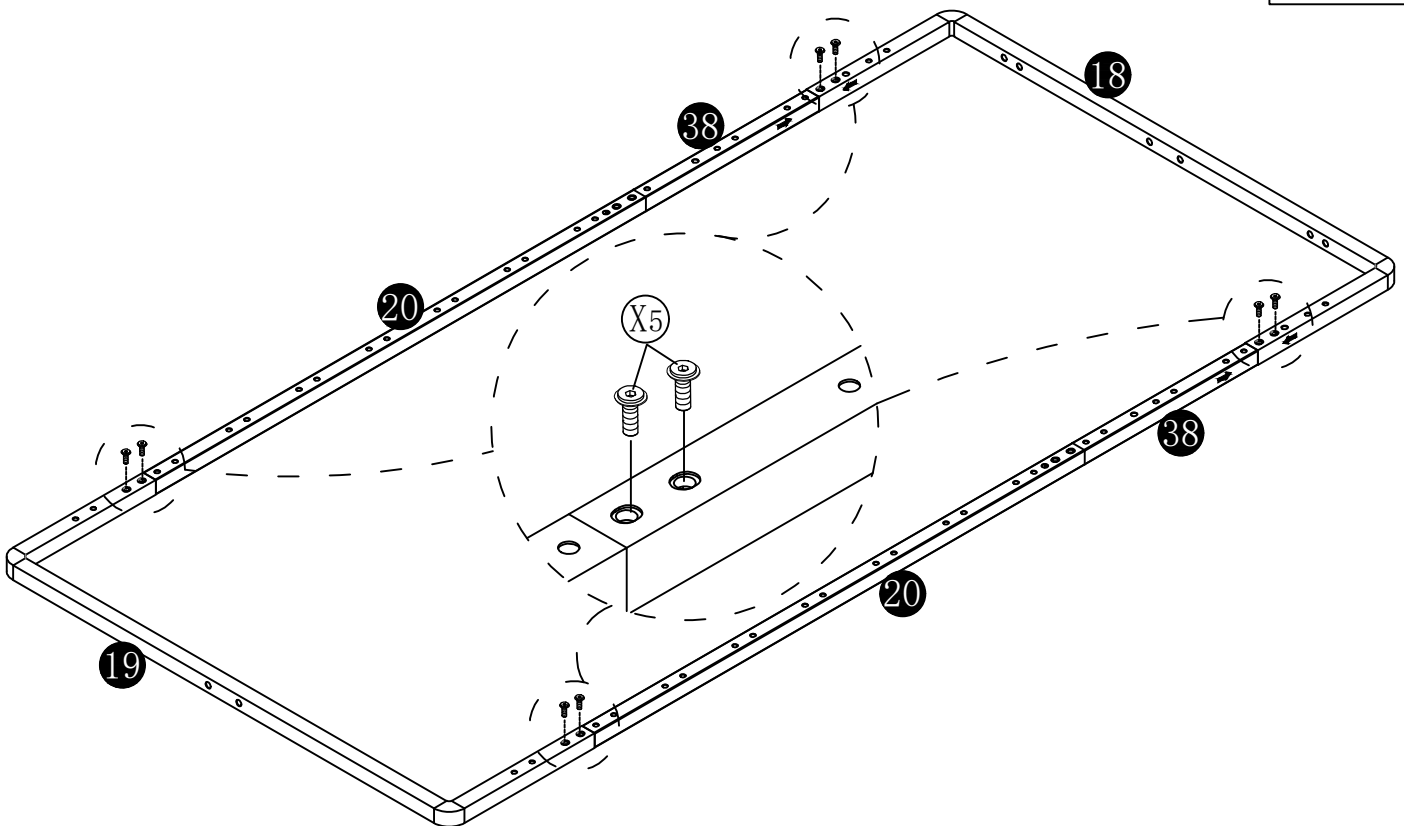

step25

X5 
8PCS

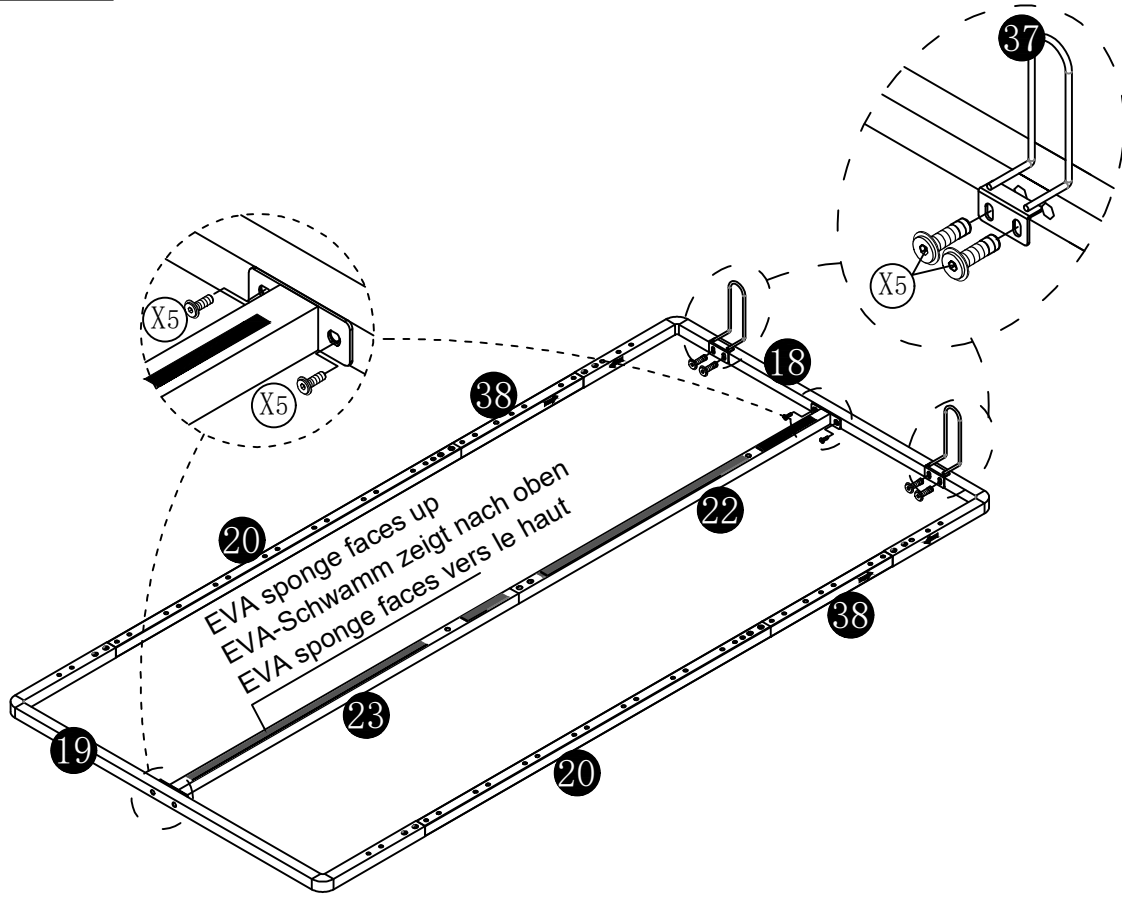

step26

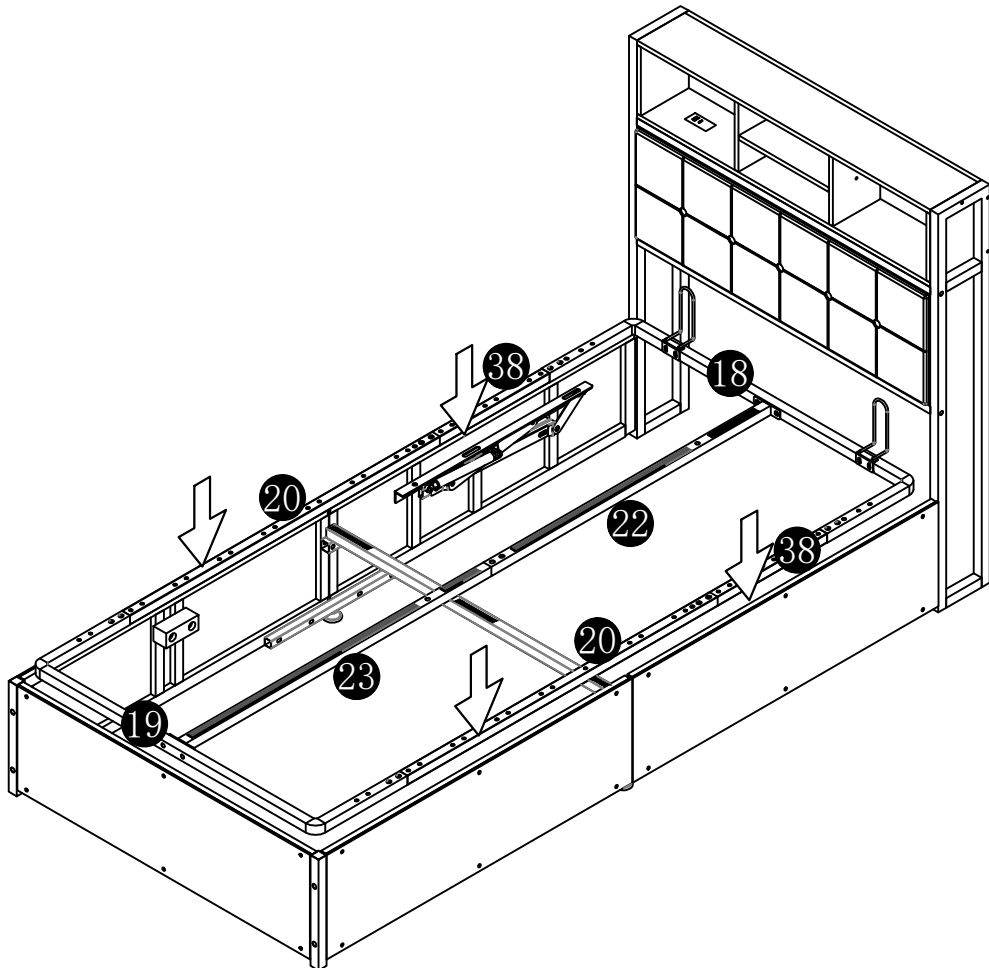

step27

X3



6PCS

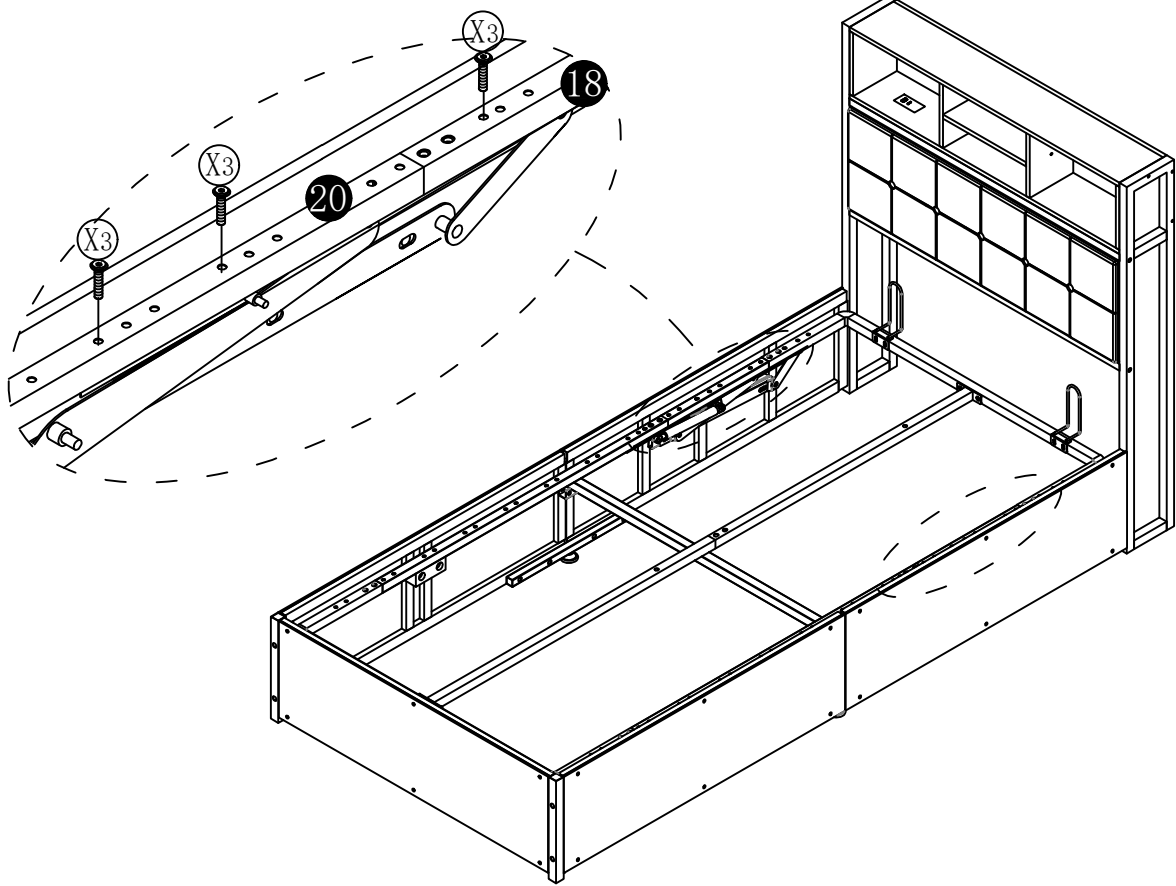

step28

X12



6PCS

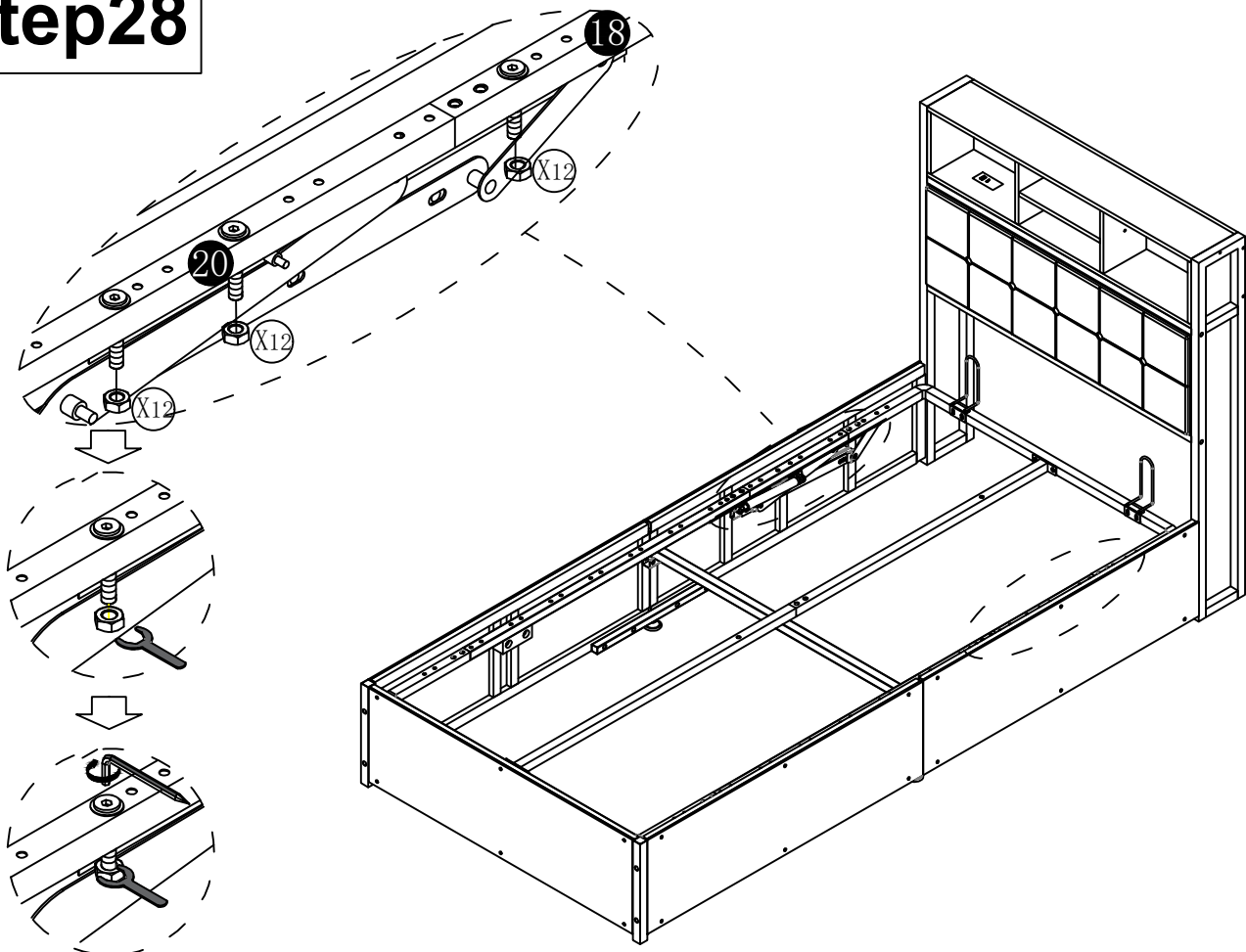

step29

X1



2PCS

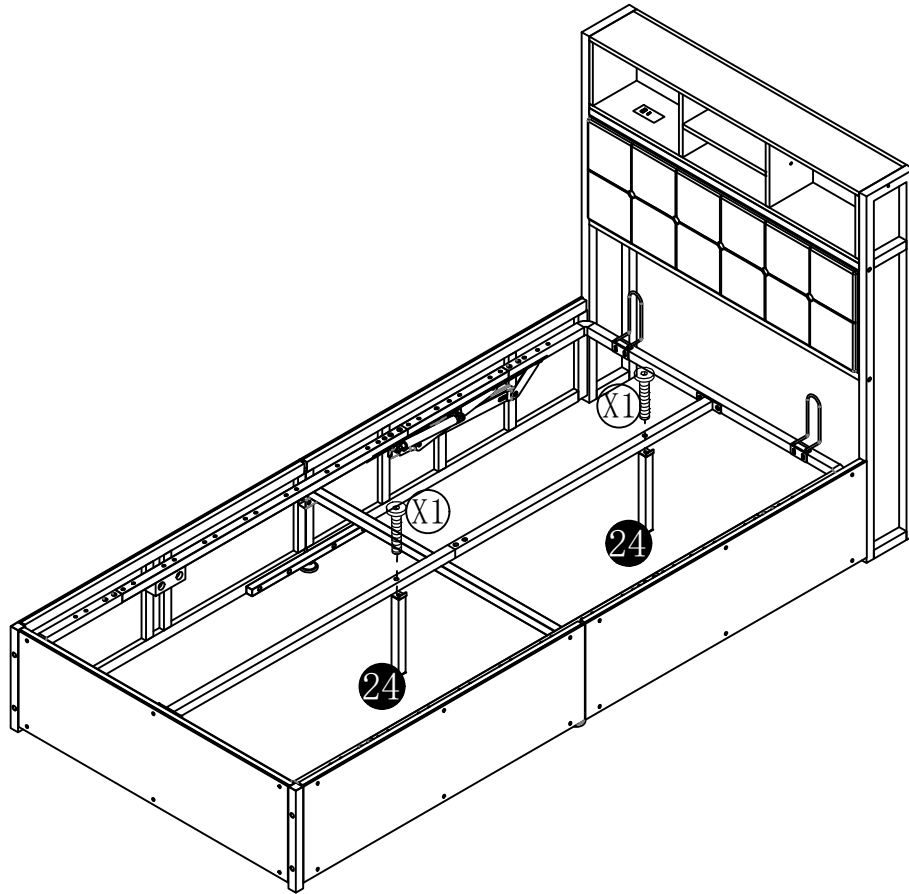

step30

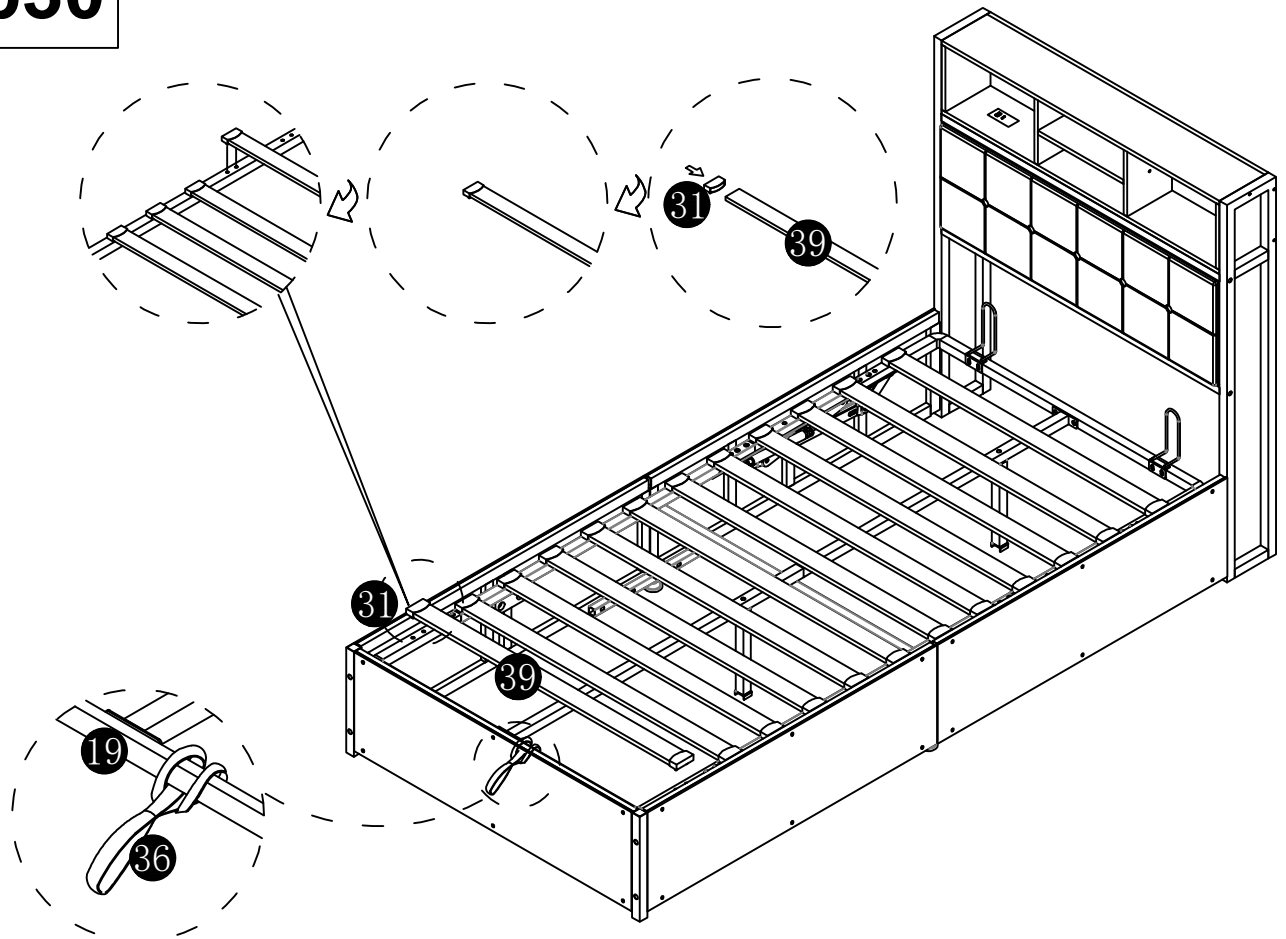

step31

X12



4PCS

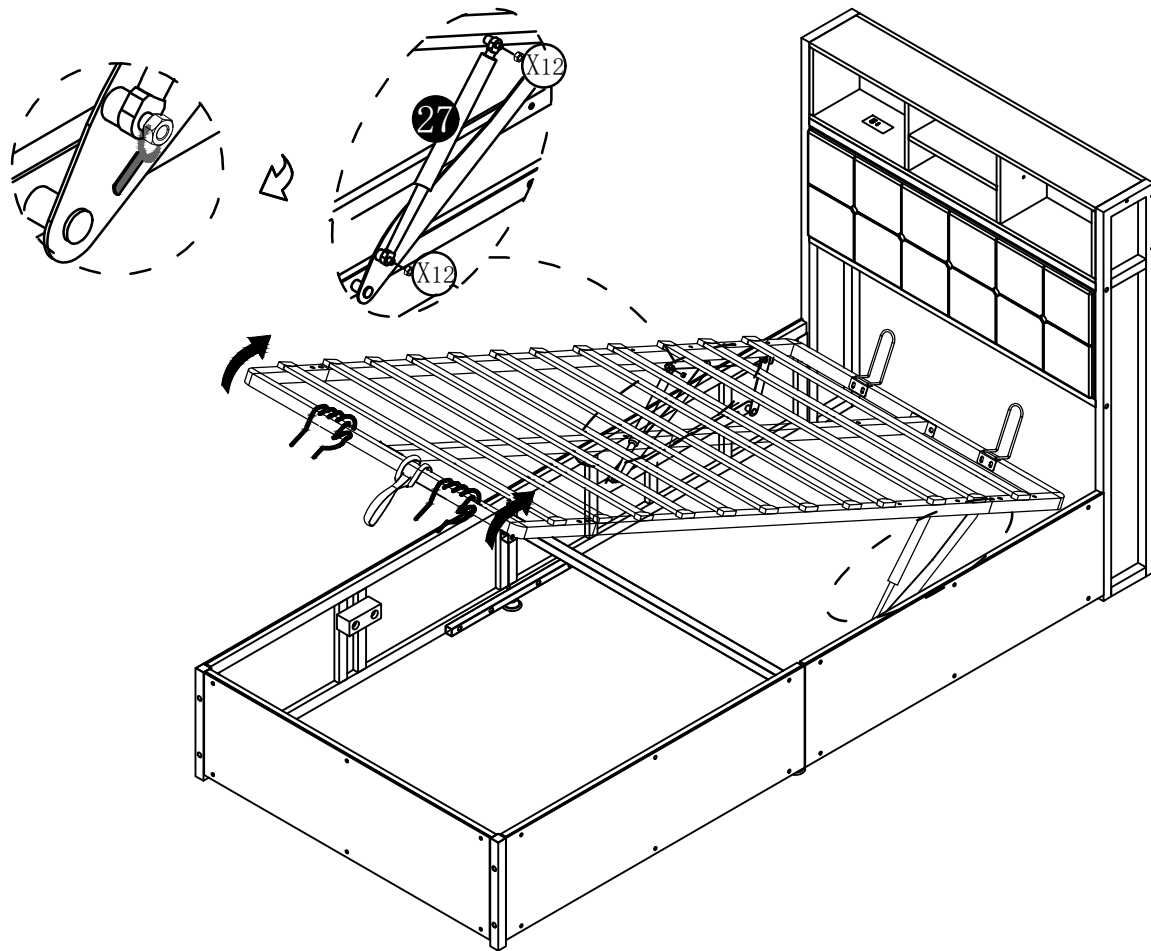

step32

IMPORTANT NOTICE OTTOMAN OPERATING INSTRUCTIONS

Once your bed frame is completely assembled, the slat unit will not operate correctly unless a mattress is placed on the slat frame. Position the mattress on the slat frame whilst it is in the closed position.

PLEASE NOTE - It takes a lot of force to make the initial movement of the ottoman. This is a design feature of the product so that it does not fall shut - the nearer to being closed the ottoman is, the easier it is to move. When the ottoman is almost shut, it will close completely under its own weight.

When lowering the slat unit for the first time, take care to make sure it does not rub unevenly on the inside face of the side rails. If it does, the bed has been assembled slightly out of square. This can be rectified by moving the foot end of the bed slightly to the left or right whilst leaving the head end stationary.

PISTONS

The pistons used in the construction of this product are extremely strong and cannot be operated by hand when taken off the ottoman. All pistons are tested for correct pressure and operation before being attached to the slat unit.

Initially it might appear that the pistons are very stiff when opening and closing the ottoman.

THIS IS PERFECTLY NORMAL

When fully assembled and the mattress is in position, please raise and lower the ottoman 4/5 times to ensure the gas piston are fully lubricated.

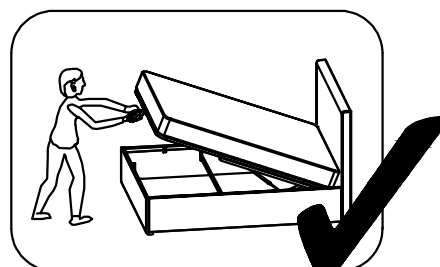
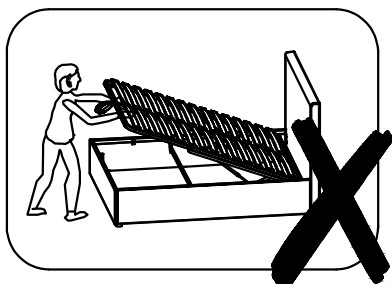

step33

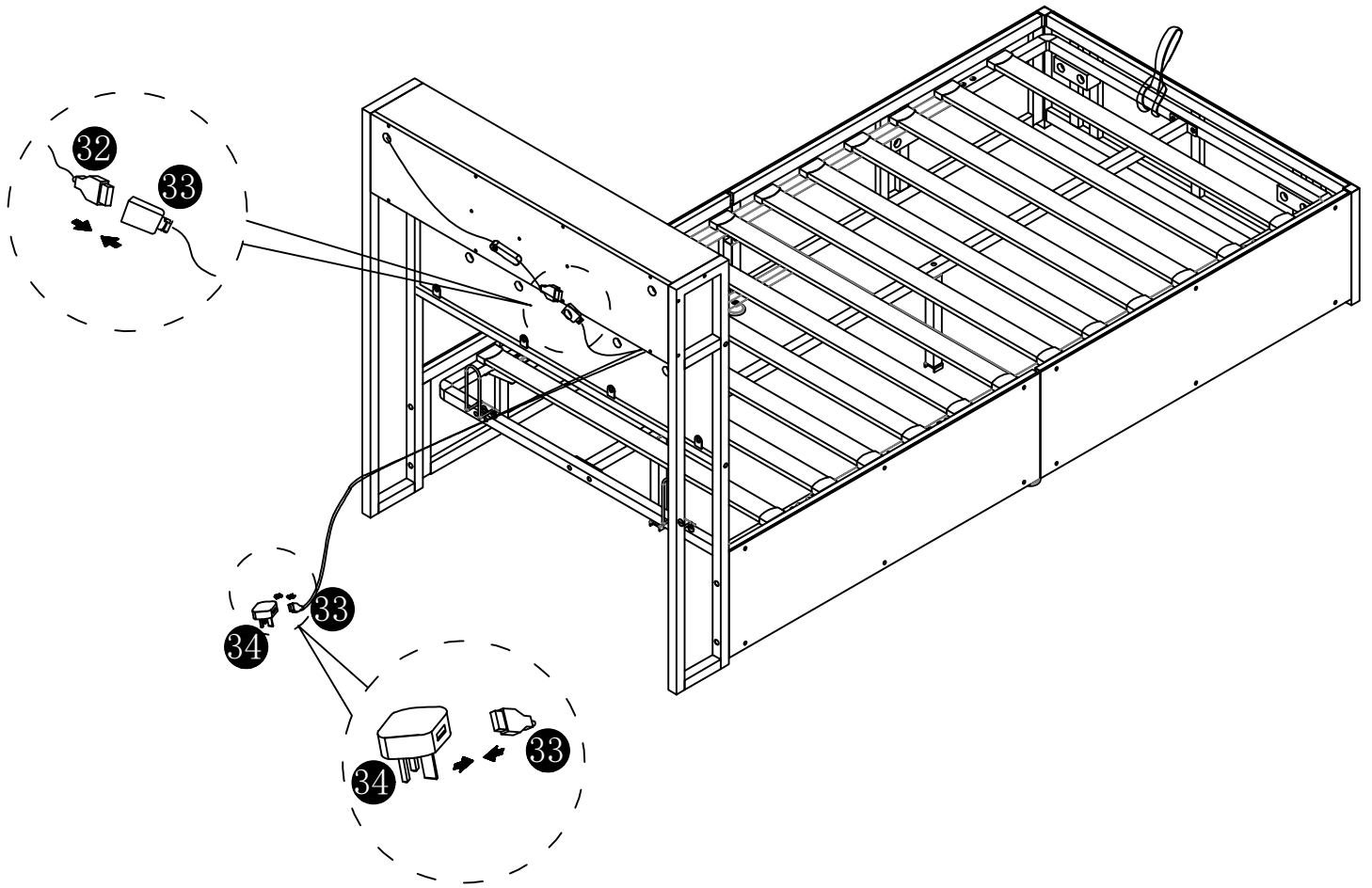

LotusLantern APP Manual

1. Software Overview

1.1 Overview

LotusLantern is a mobile APP to control LED strip by both IOS and Android phones.

The traditional control ways like infrared, 433MHz, 2.4GHz and others old wired ways will be replaced by mobile phone control way with convenient, powerful and scalable features.

Through this mobile APP , you can not only control the color, brightness and color temperature of the LED strips but also set up all kinds of fancy flash mode ; Also this APP can change the light of the LED strip according to the rhythm of the music. This APP can set and control several LED strips through Bluetooth and the operation is very simple, easy to learn and easy to use.

1.2 Features

- Adjust color LED strips with 60,000 colors to change color and brightness and adjust monochrome LED strips to change brightness and color temperature
- Play music or turn on a sound playback device, you can let the light change the color and brightness with the rhythm of music, the music rhythm beautiful
- Inside multiple setting mode for color change and control LED strips without mobile
- Long distance control with omni-directional antenna, and many-to-many group control mode
- Once the connection is successful, connect automatically next time

1.3 Performance

LotusLantern APP is easy for use as well as great compatible with all kinds of smart phones; After the actual test of hundreds of mobile phones verification, the compatibility is above 95% of mobile phones in the market. APP is small and convenient, it consumes less system resources, so the requirements of the mobile configuration are low. Control delay is small, the operation feels good, light control is smooth with people's visual sense.

2. Operating Environment

This APP program requires phones of system above Android 4.3 and iOS 8.0. Mobile phone configuration is not limited.

3. Instructions

Note: Android version and iOS version download and use the same method, here in the Android version as an example.

3.1 APP Download

Scan the QR code

iOS and Android systems can download the "LotusLantern" APP by scanning the QR code. Open the browser or other tools with "Scan QR code" function, scan the "LotusLantern" QR code as below:



3.2 App Operation

(1) Click on the LotusLantern APP icon, enter the APP page:

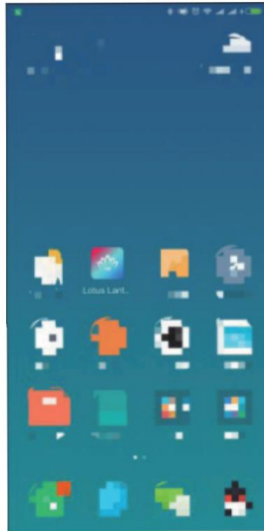

(2) After entering the APP interface, if Bluetooth is not enabled, "an application wants to enable the Bluetooth function of this device." Click [Allow]

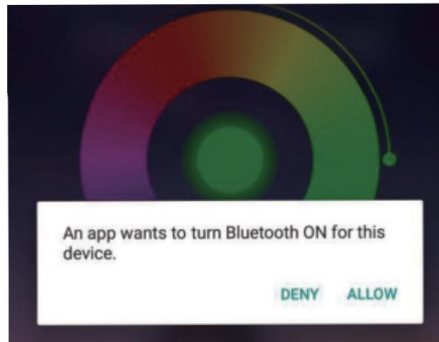

(3) switch to color and brightness interface:

Click to show the lamp list

Switch the color wheel

Display the RGB value
Click to manual adjustment view

Click to shift the interface

Click to display setting view

Lamp switch button

Adjust the color

Click square icon to adjust the color

(4) click to show the lamp list, view lamp list:

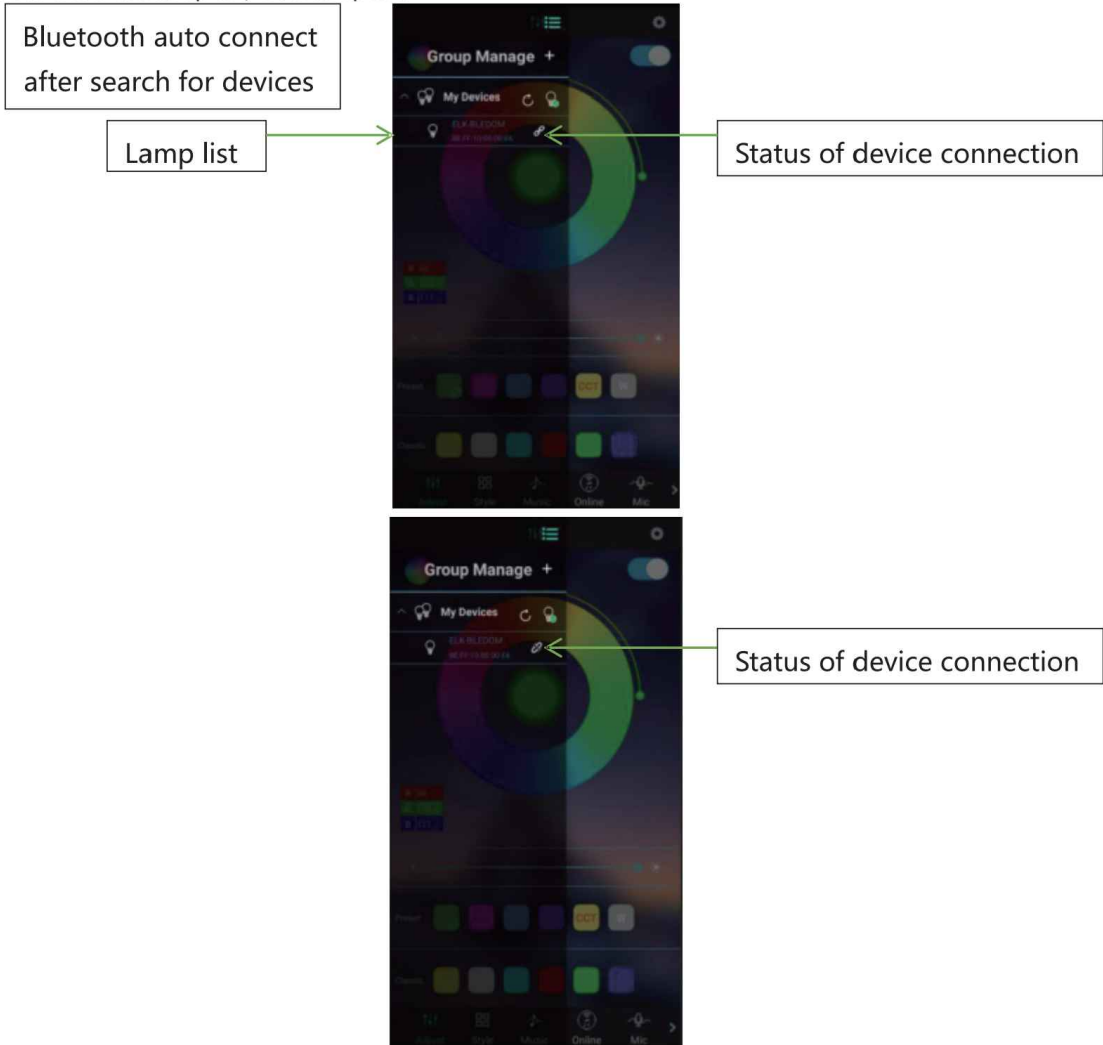

(5) Click to RGB manual adjustment view:

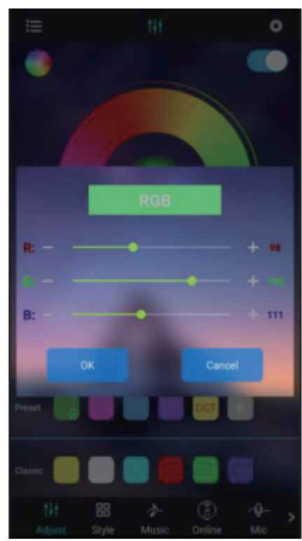

(6) switch to the mode interface:

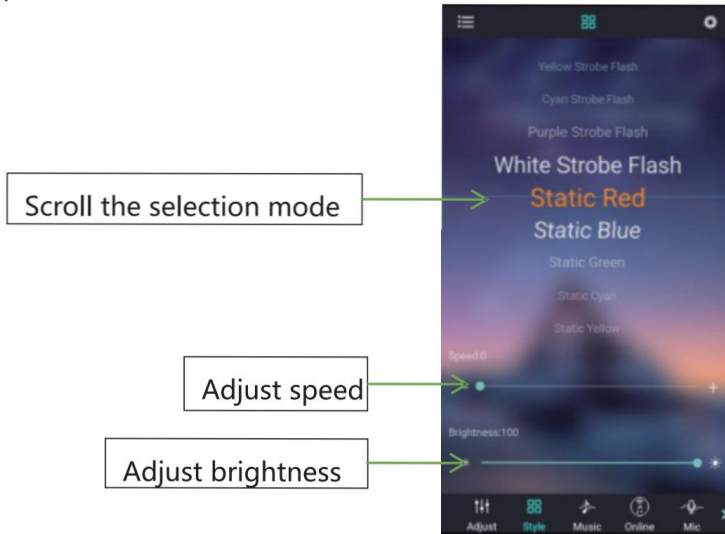

(7) switch to the music rhythm interface:

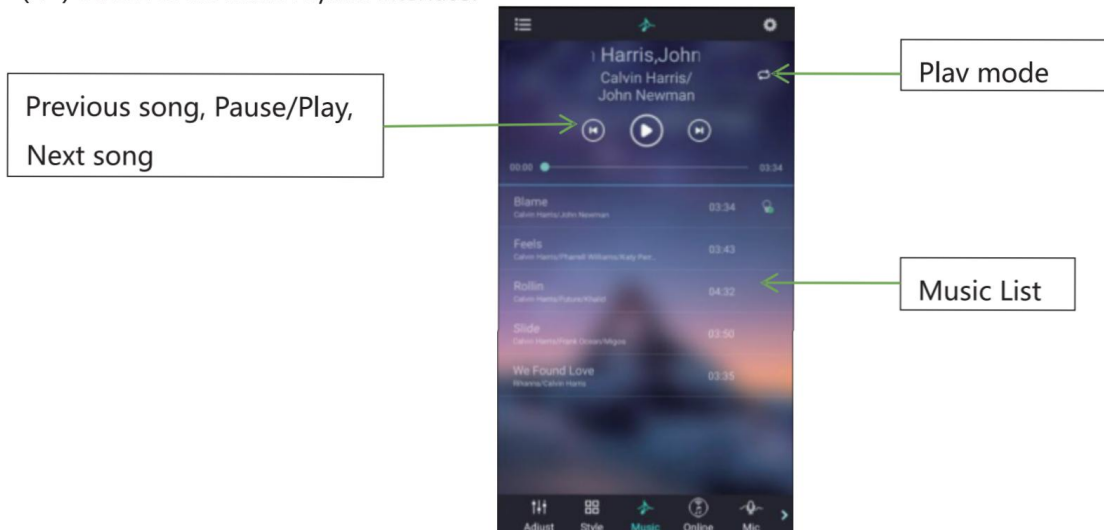

(8) Switch to the online music interface:



(9) Switch to the microphone rhythm interface:

Music rhythm through cell phone microphone

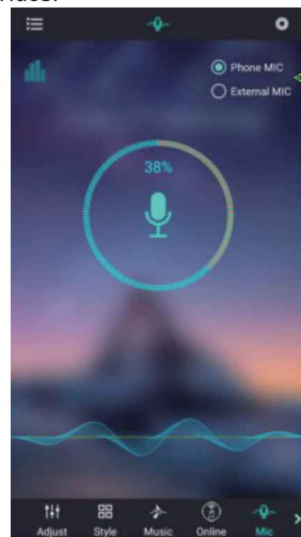

Switch phone microphone and external microphone

Music rhythm through the microphone on the product

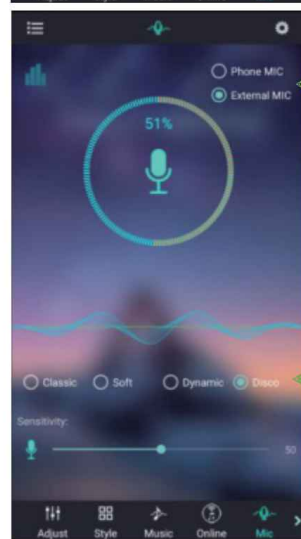

Switch phone microphone and external microphone

4-style rhythm

Change the sensitivity of MIC to match the sound

(10) Switch to the schedule interface:

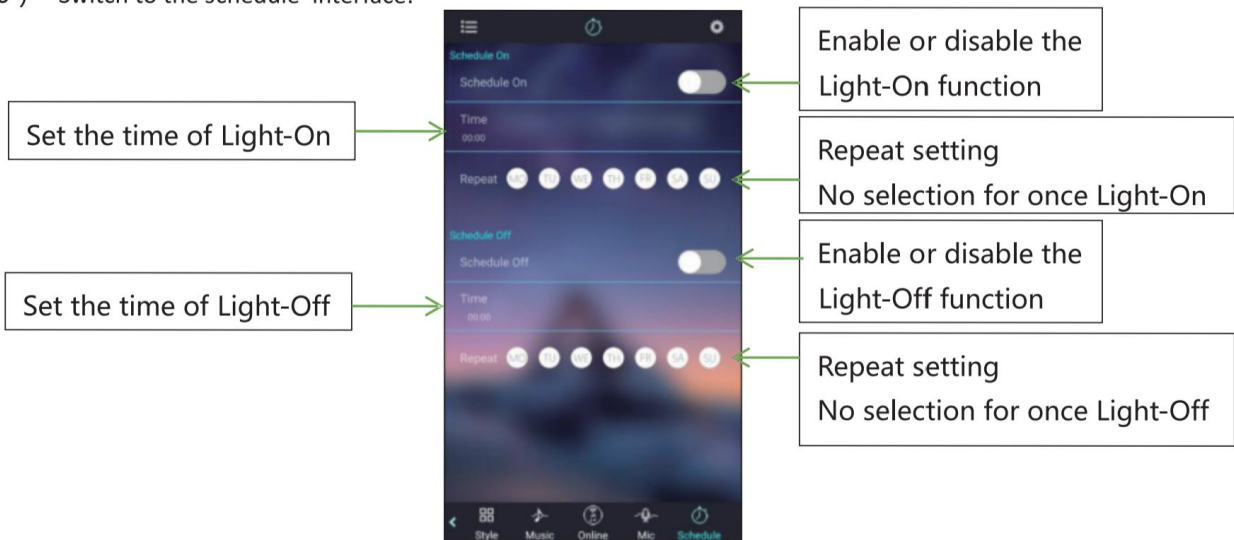

(11) Switch to the modify pin sequence interface:

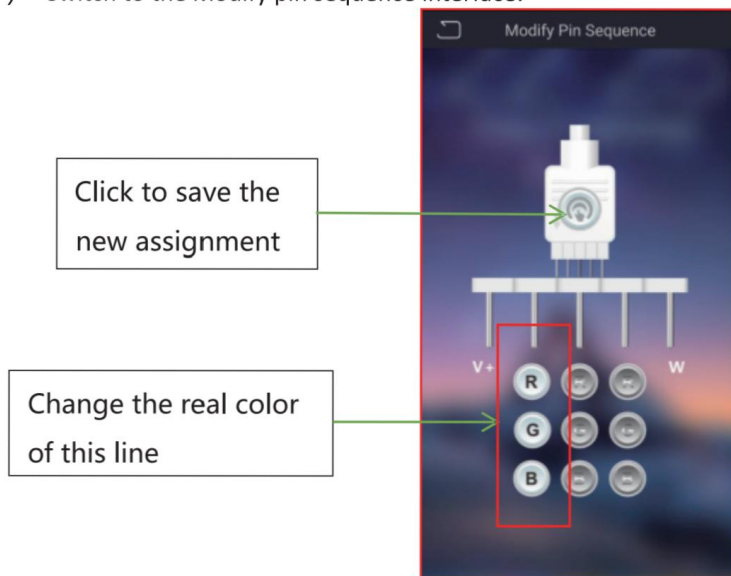

Technical parameters:

Working temperature: -20-60°C (-4 F°-140 F°)

Power supply voltage: DC5-24V

Output: 3 Loops

Static power consumption: <0.5W

Output current: <3A(each circuit)5V <30W 12V <108 24V <21 6W