

Assembly Instructions

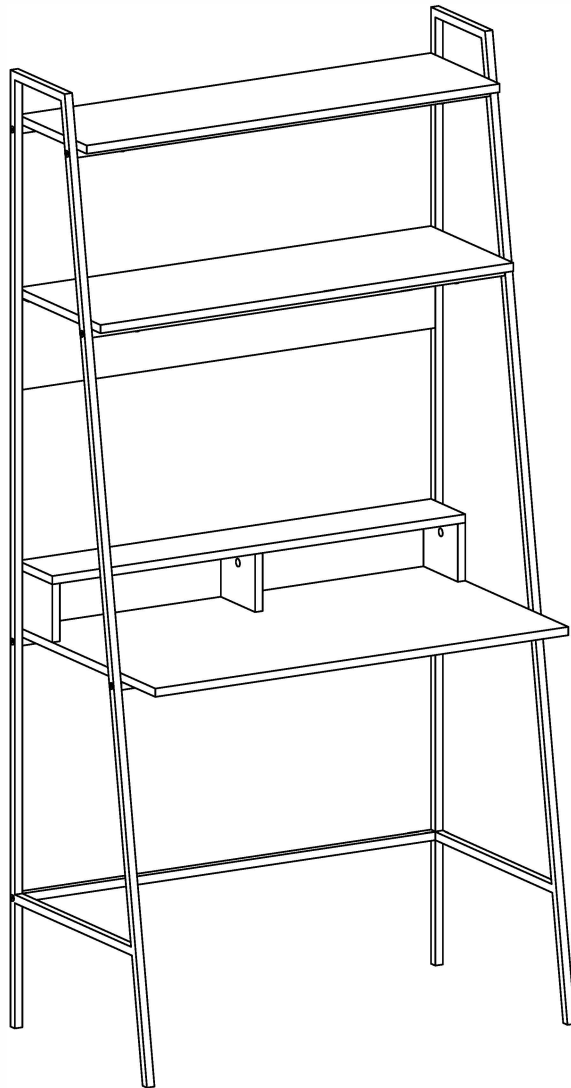

General Assembly Guidelines

- I. Ensure that all parts and hardware are available before beginning assembly.
- II. Follow each step carefully to ensure the proper assembly of this product.
- III. Two people are recommended for ease in the assembly of this product.
- IV. The three main types of hardware used to assemble this product are: wood dowels, screws and bolts.
- V. The provided glue is to secure wood dowels in place. When first inserting dowels, locate the appropriate hole for the dowel, place a small amount of glue in the hole and insert the dowel. Wipe away excess glue immediately.

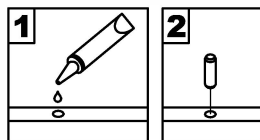

In future assembly steps when dowels are necessary to attach assembly parts together, place a small amount of glue on the end of the dowel before attaching parts together. Wipe away excess glue immediately.

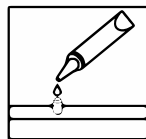

- VI. A Phillips head screwdriver is required for the assembly of this product .

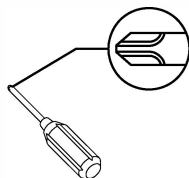

- VII. Power tools should not be used to assemble this product.







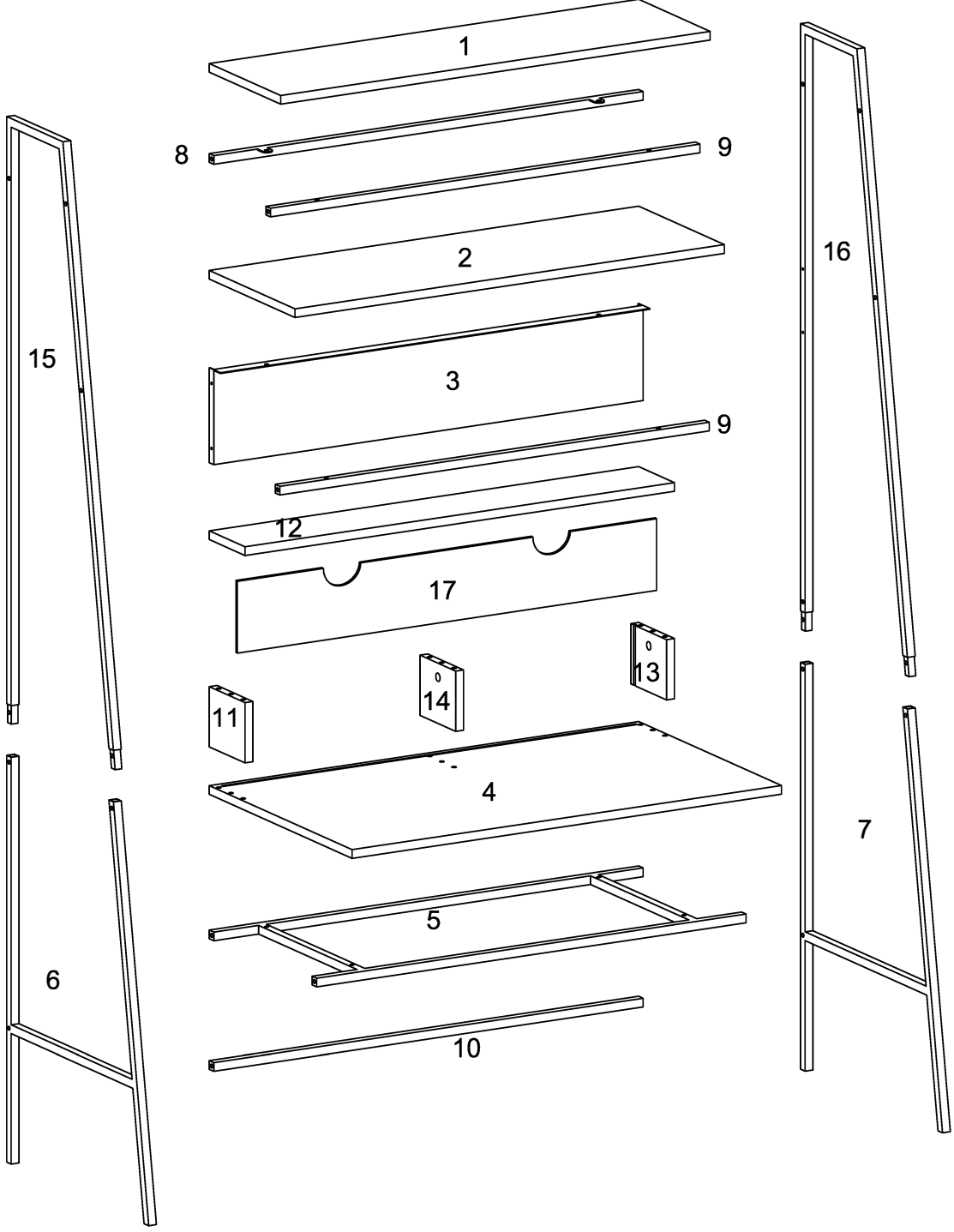







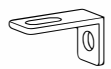

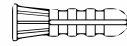
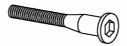

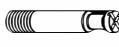
- VIII. Drill may be needed for securing product to wall.

Parts List



Hardware List

A		Ø1/4"x12mm	Bolt	5 pcs
B		Ø1/4"x25mm	Bolt	20 pcs
C		4mm	Hex Key	1 pcs
D		Ø16x6.5x1.0mm	Washer	1 pcs
E		40x25x20mm	Bracket	1 pcs
F		Ø4x30mm	Screw	1 pcs
G			Wall anchor	1 pcs
H		Ø6x50mm	Bolt	3 pcs
J		Ø8x30mm	Wooden dowel	12 pcs
K		Ø15x9.5mm	Cam lock	3 pcs
L		Ø6x32mm	Cam bolt	3 pcs
M		Ø30mm	Sticker	3 pcs
N		Ø4x12mm	Screw	12 pcs
P		40x12x2mm	Plate	2 pcs
Q			Corner plate	2 pcs
R			Plastic wedge	4 pcs
S		Ø3x17mm	Screw	4 pcs
T			Glue tube	1 pcs

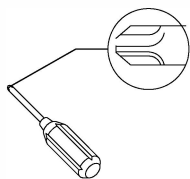

Philips head screwdriver required for assembly
(not included)

*The hardware quantities listed above are required for proper assembly.
Some extra hardware may also have been included.*

Step 1

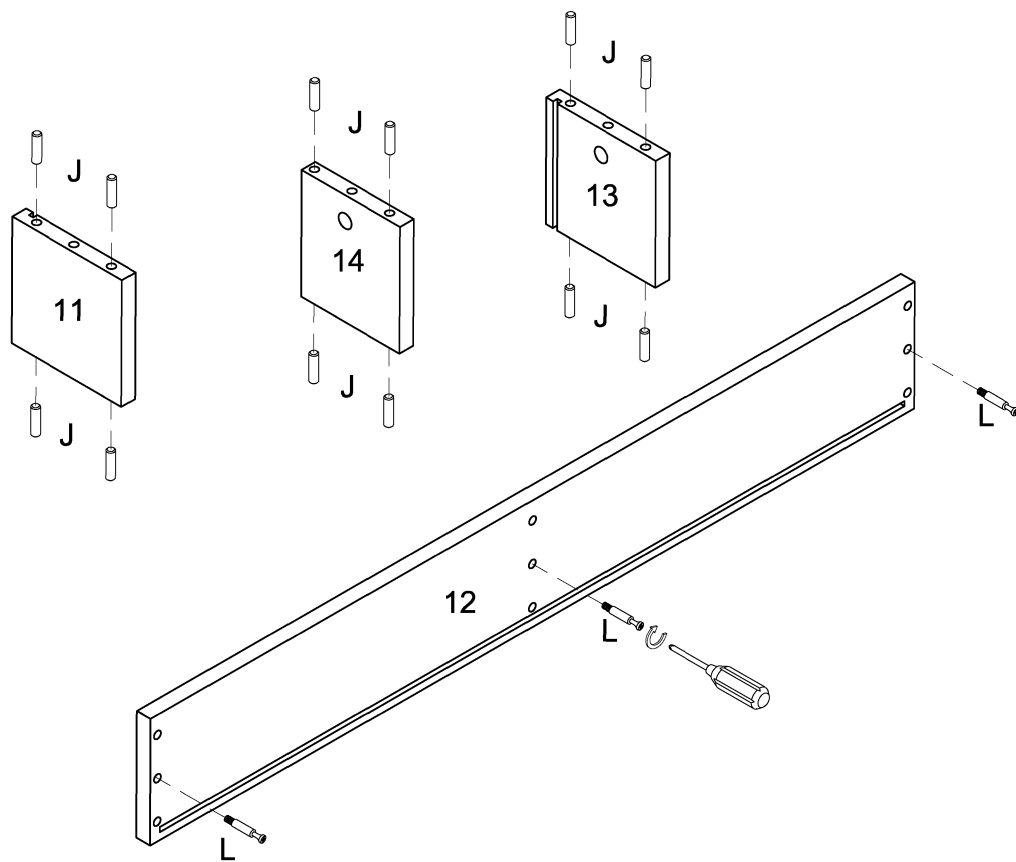

Insert wooden dowel (J) into part (11,13,14), secure cam bolt (L) to part (12) with screwdriver.

Step 2

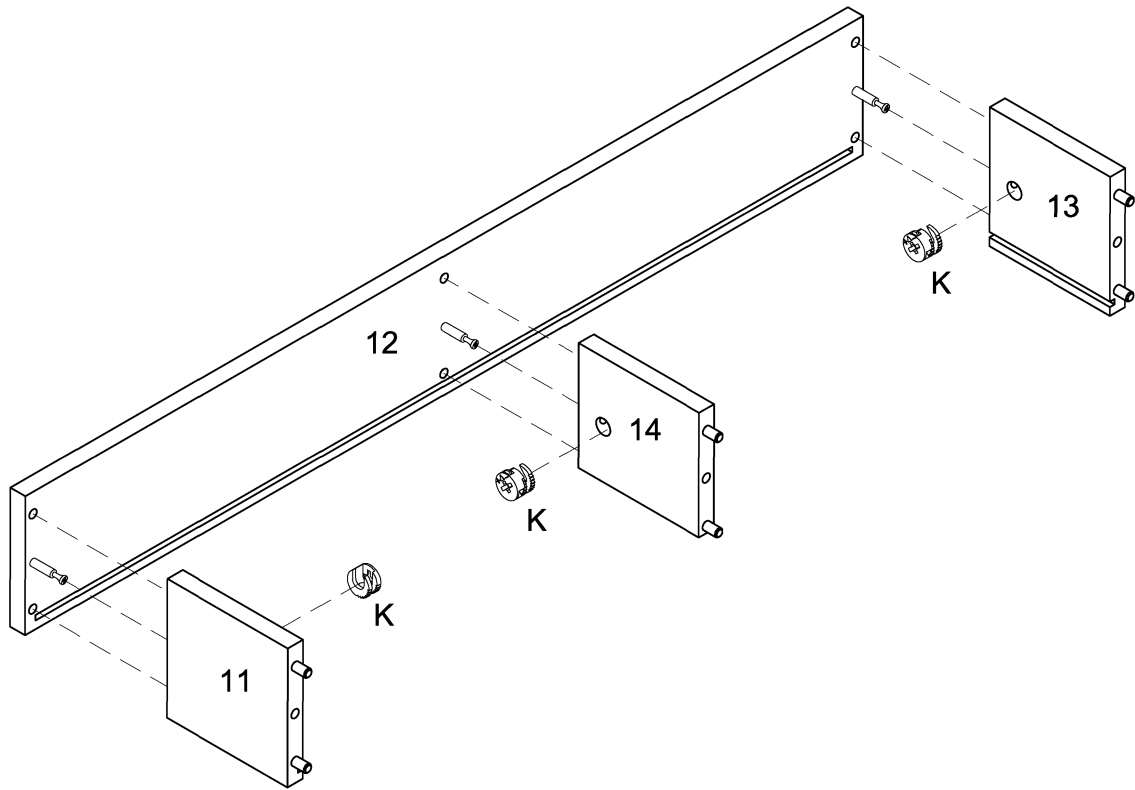
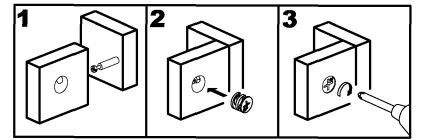

Insert part (11,14,13) to part (12), then secure cam lock (K) to part (11,14,13) with screwdriver.

Step 3

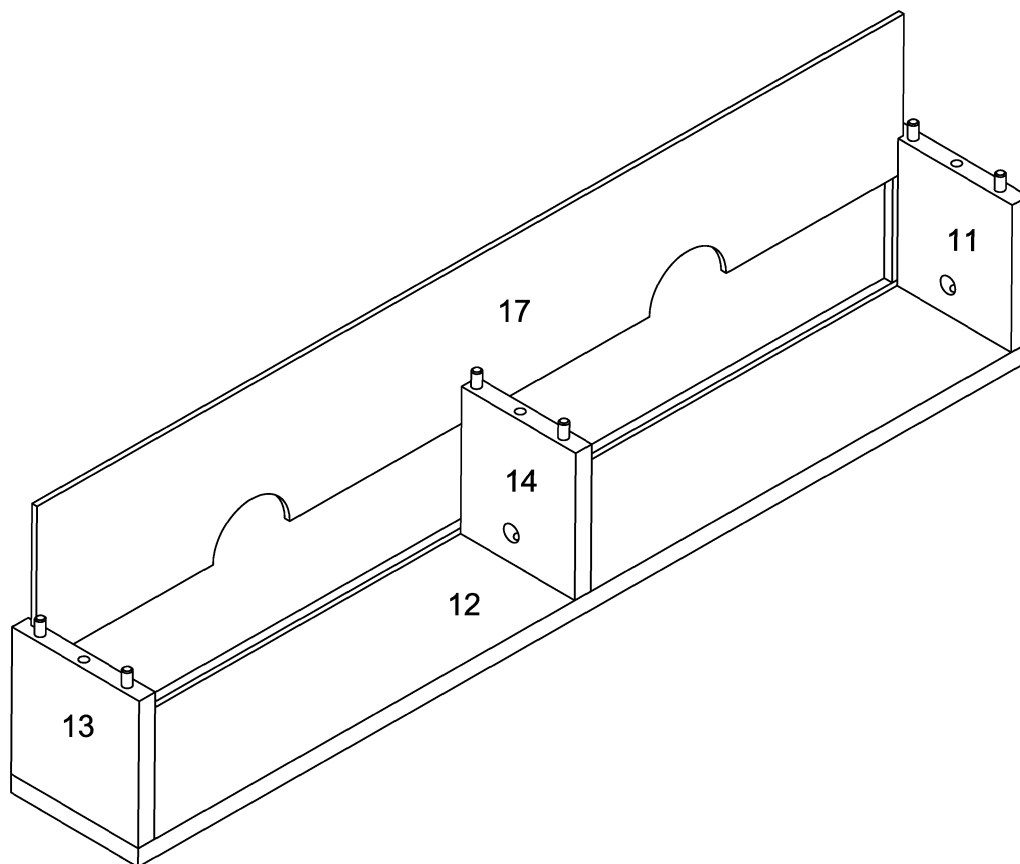

Insert part (17) to part (12) as per diagram.

Step 4

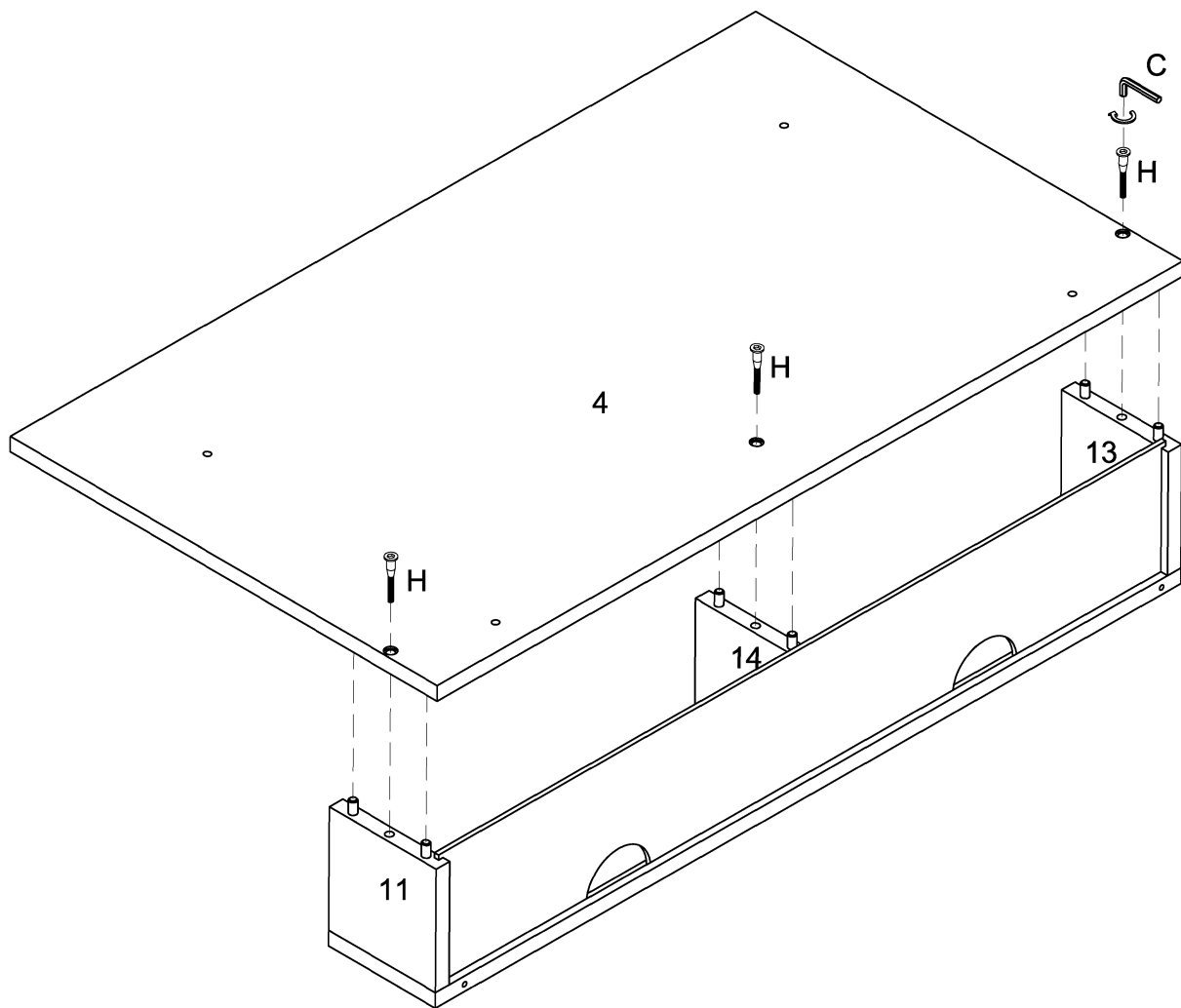

Attach part (4) to part (11,14,13) using bolt (H) with hex key (C).

Step 5

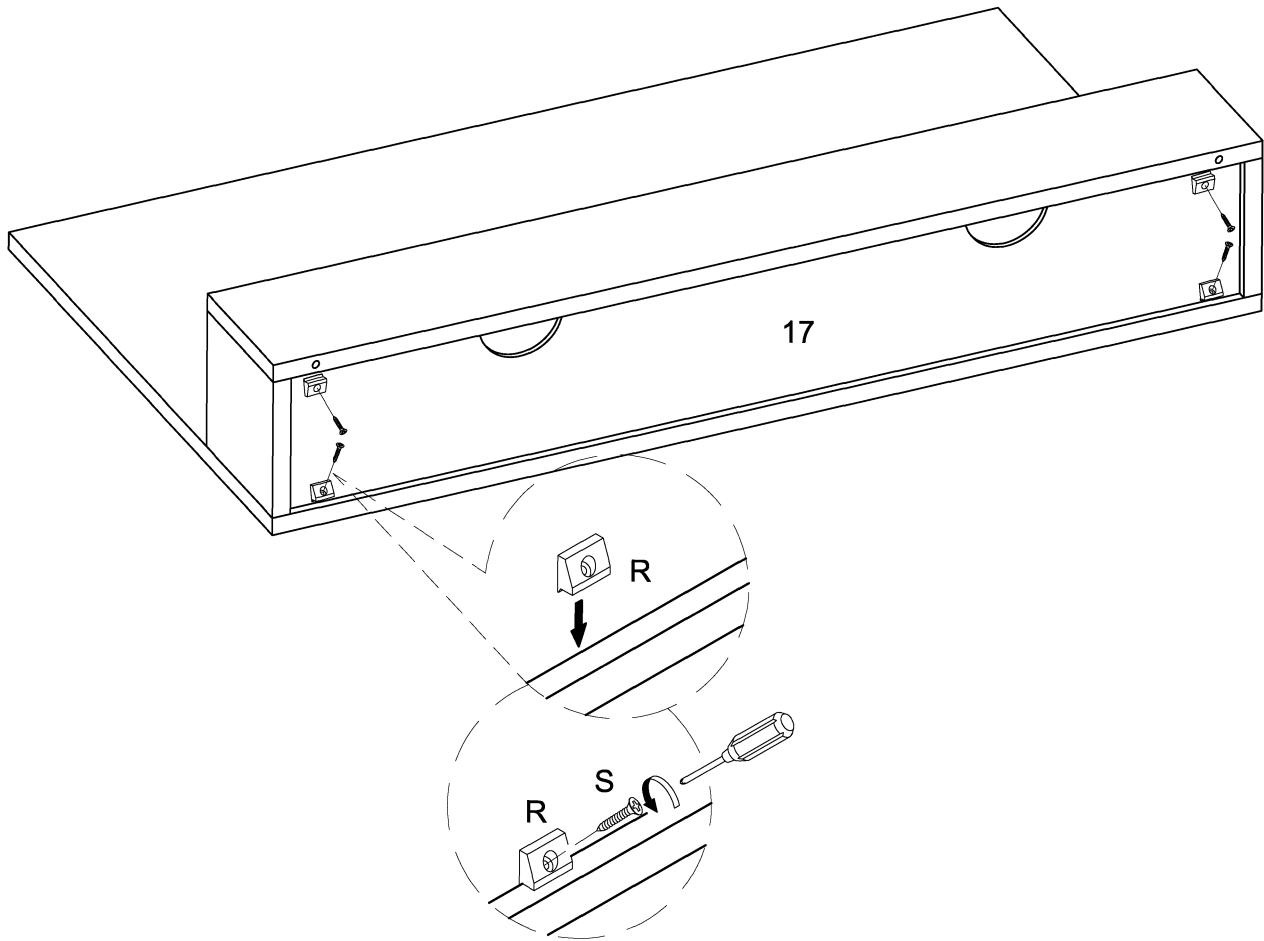

Attach plastic wedge (R) to part (17) using screw (S) with screwdriver.

Step 6

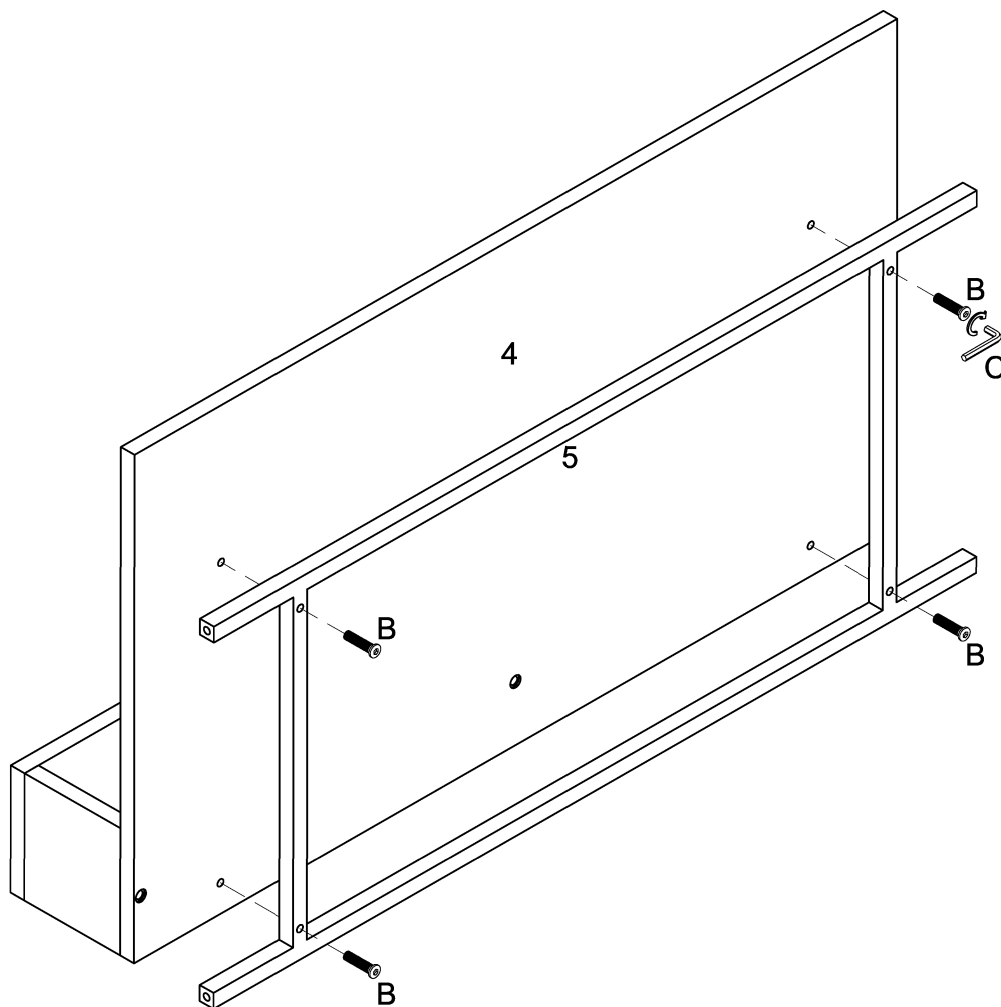

Attach part (5) to part (4) using bolt (B) with hex key (C).

Step 7

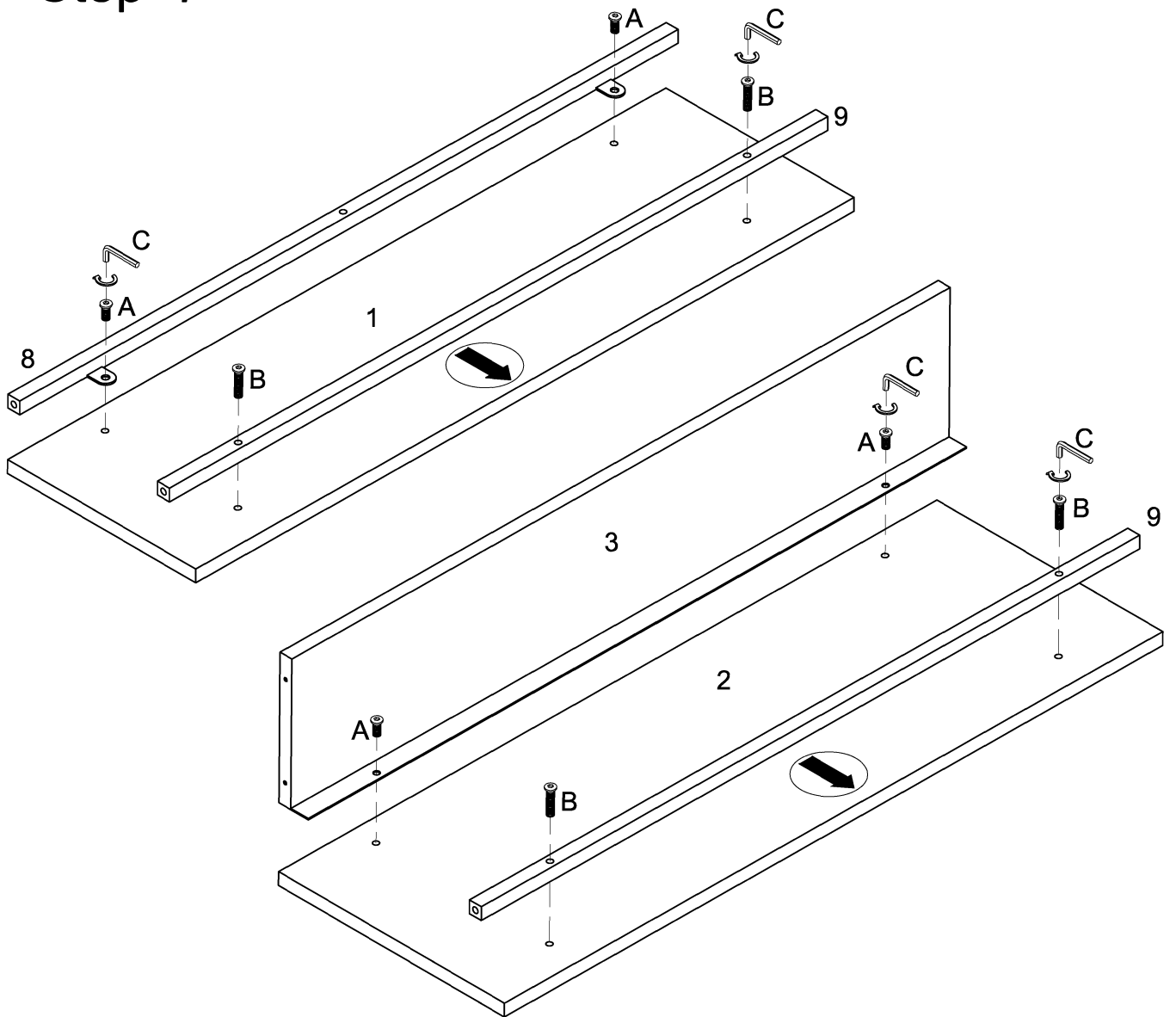

Attach part (8,9) to part (1), part (9,3) to part (2) using bolt (A,B) with hex key (C).

Step 8

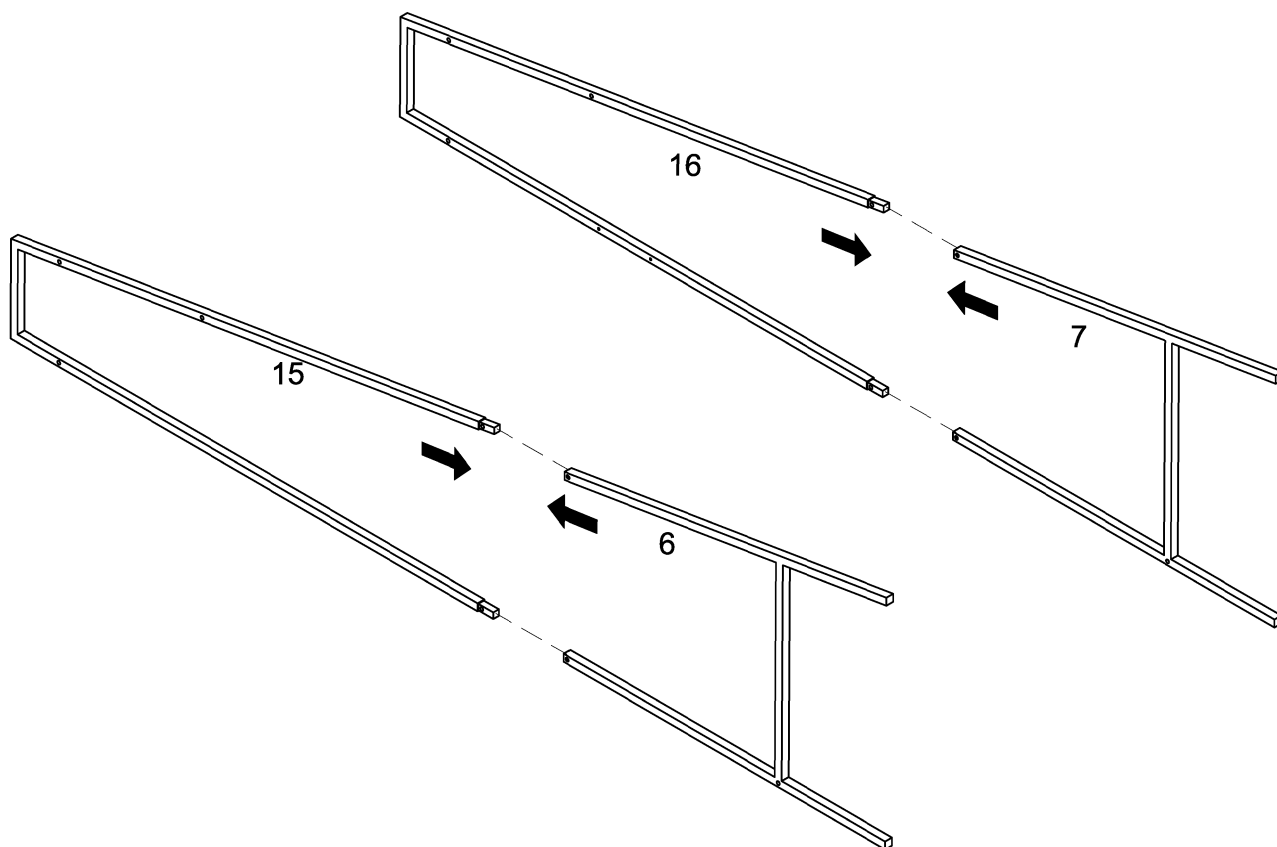

Attach part (15) to part (6), part (16) to part (7).

Step 9

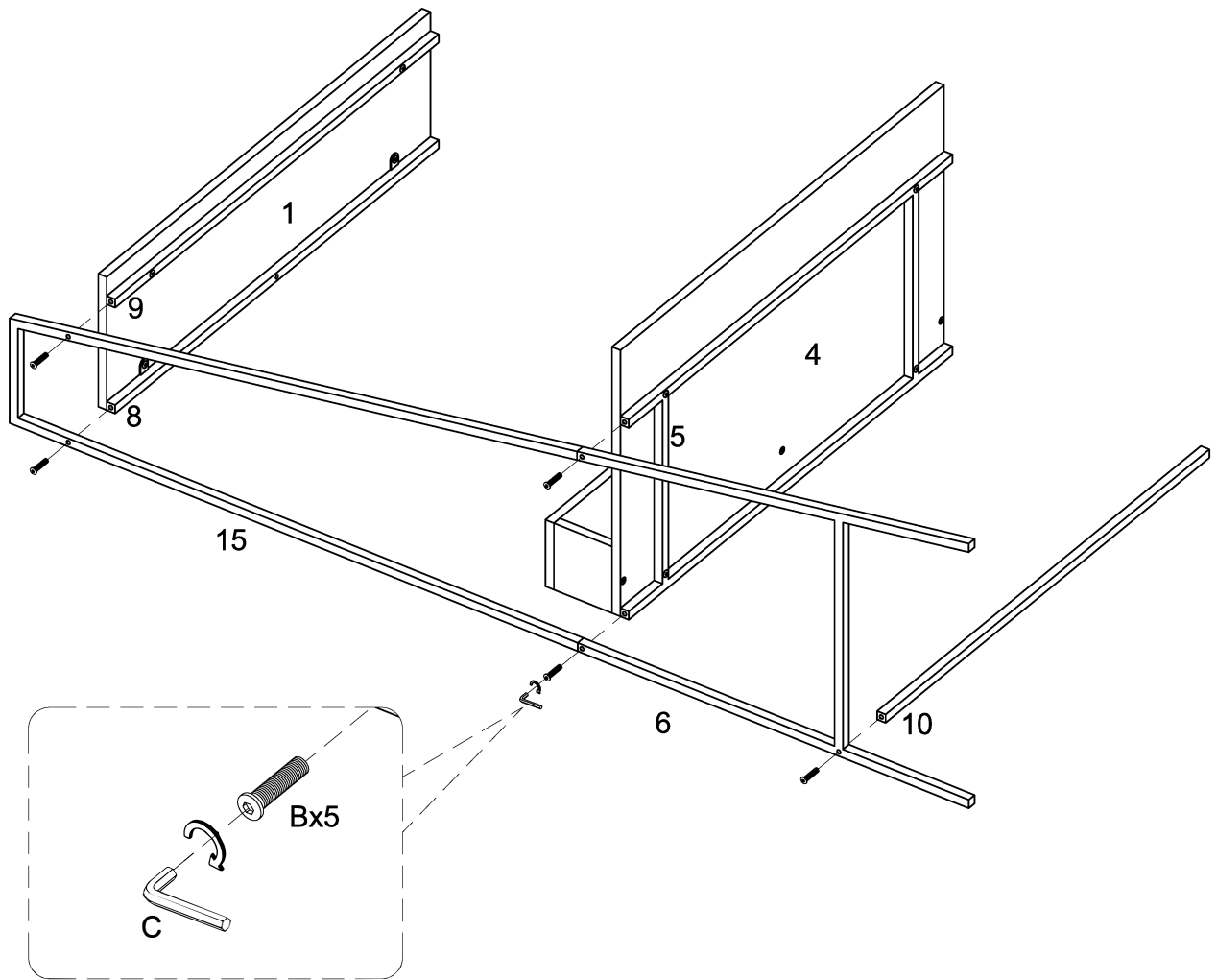

Attach part (15,6) to part (1,9,8), part (5,4), part 10 using bolt (B) with hex key (C).

Step 10

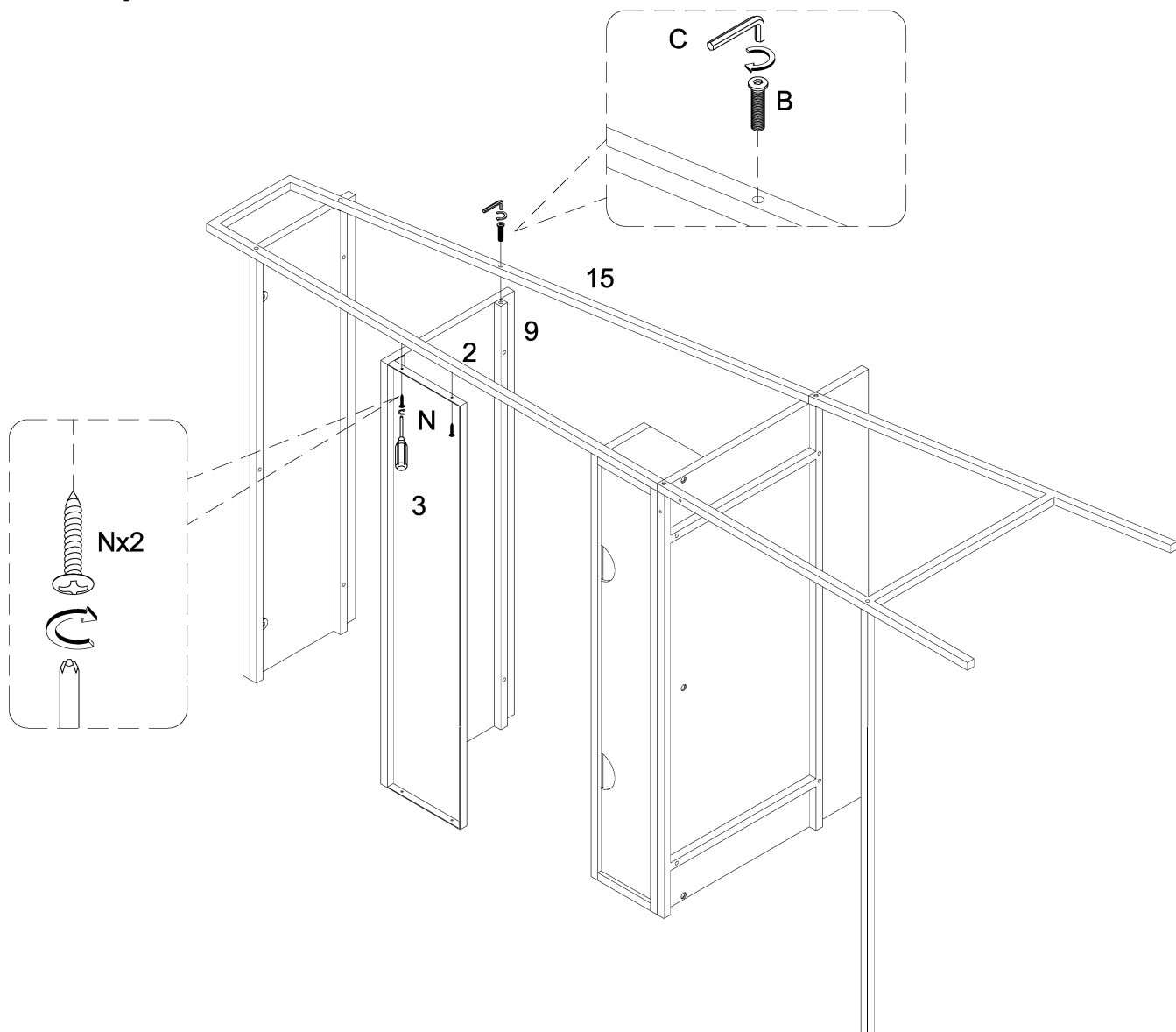

Attach part (15) to part (3,2,9) using bolt (B) and screw (N) with hex key (C) and screwdriver.

Step 11

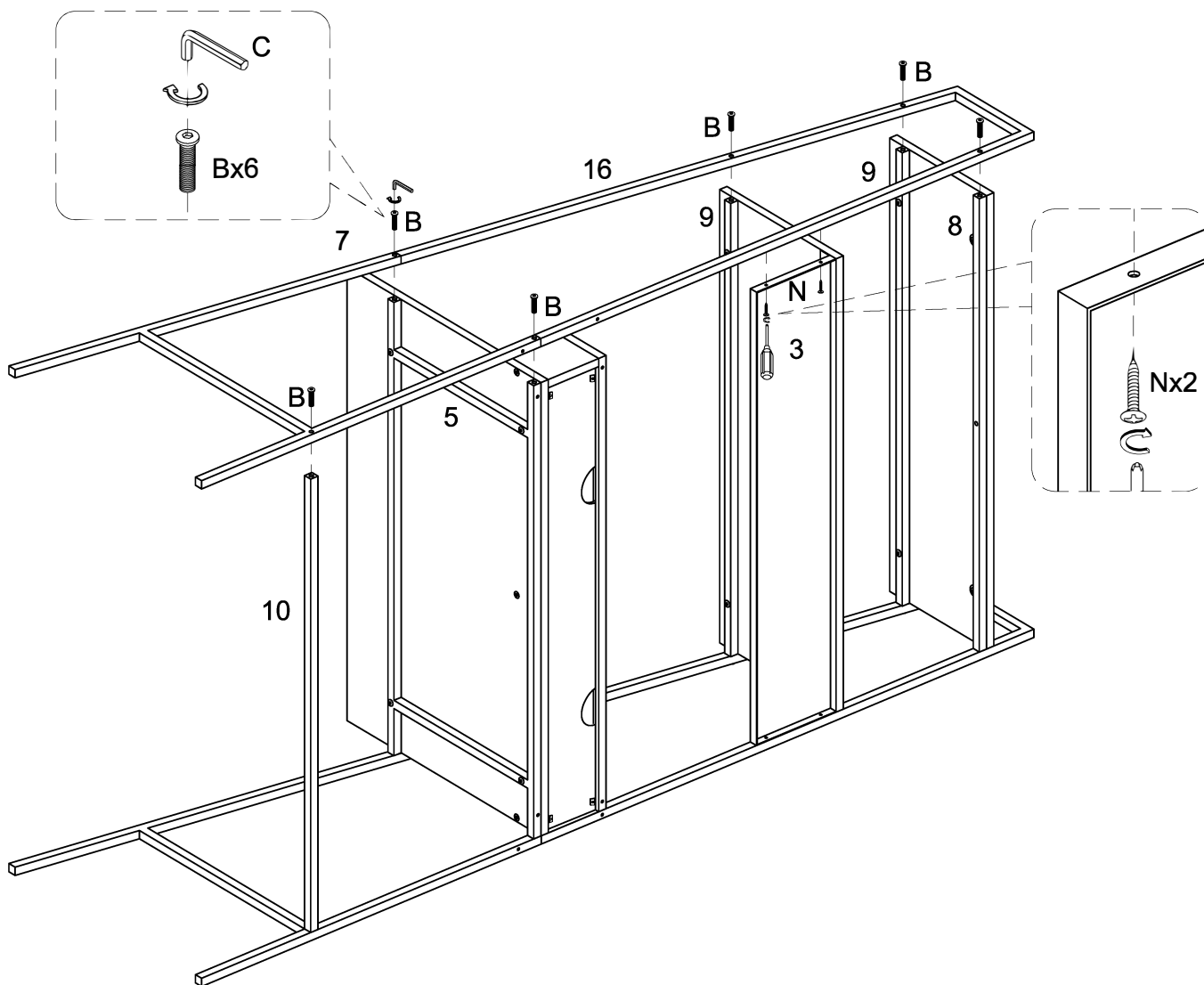

Attach part (16,7) to part (9,8,5,3,10) using bolt (B) and screw (N) with hex key (C) and screwdriver.

Step 12

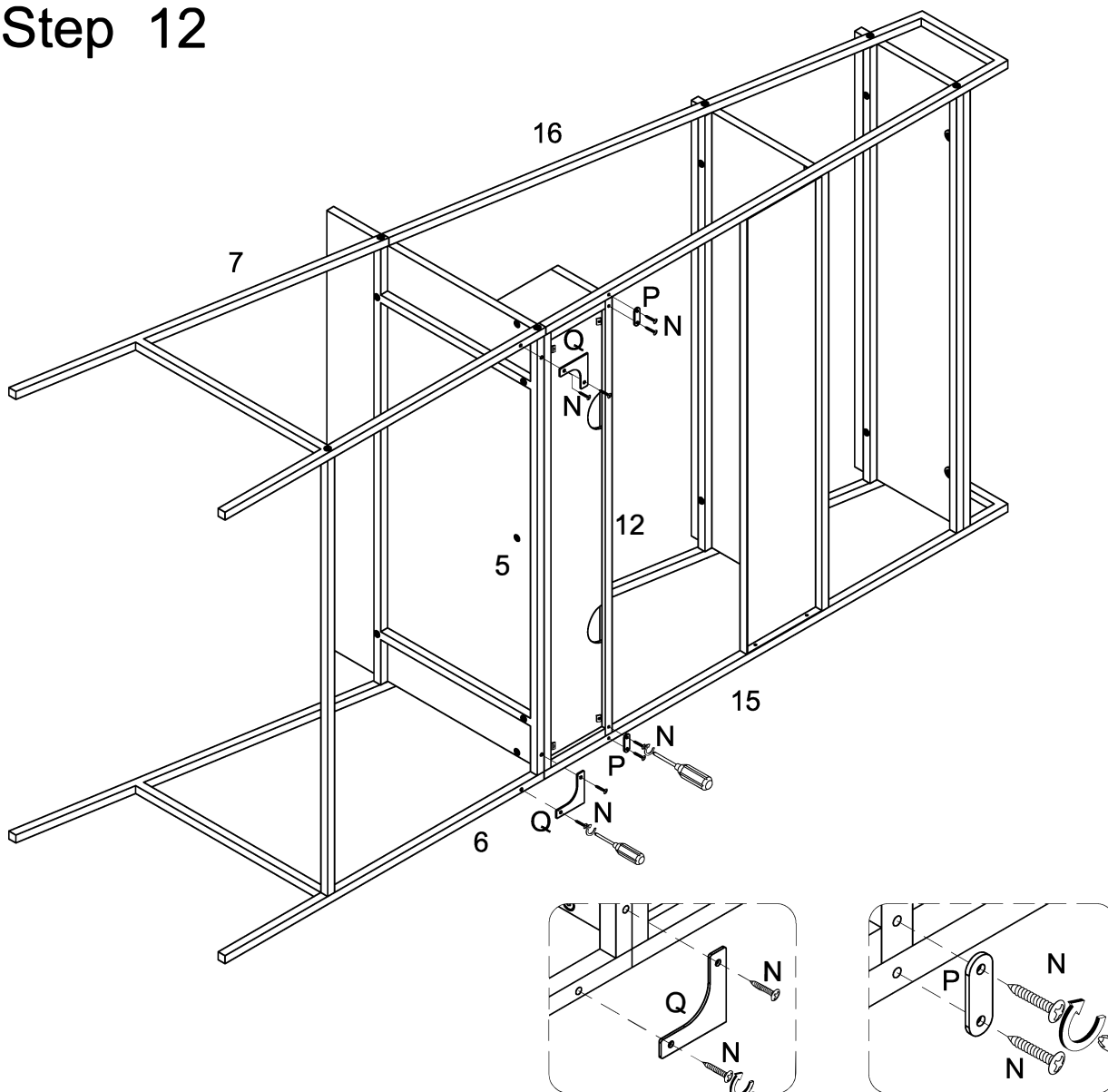

Attach plate (P) and corner plate (Q) to part (12,5) using screw (N) with screwdriver.

Step 13

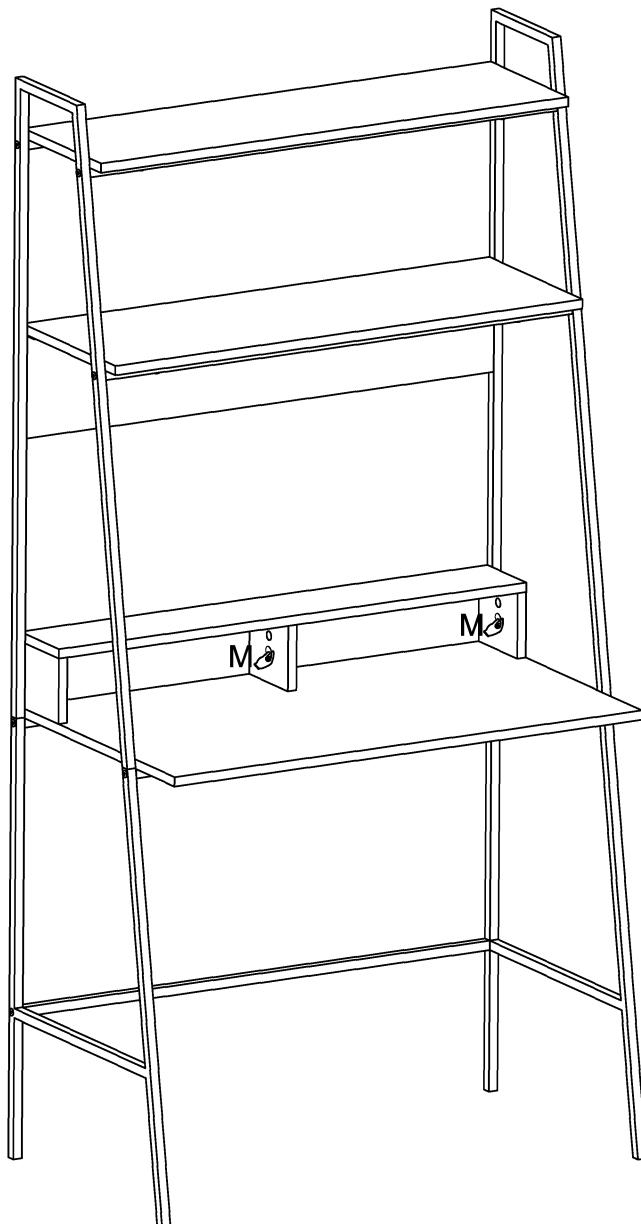

Place sticker (M) over holes as per diagram.

Step 14

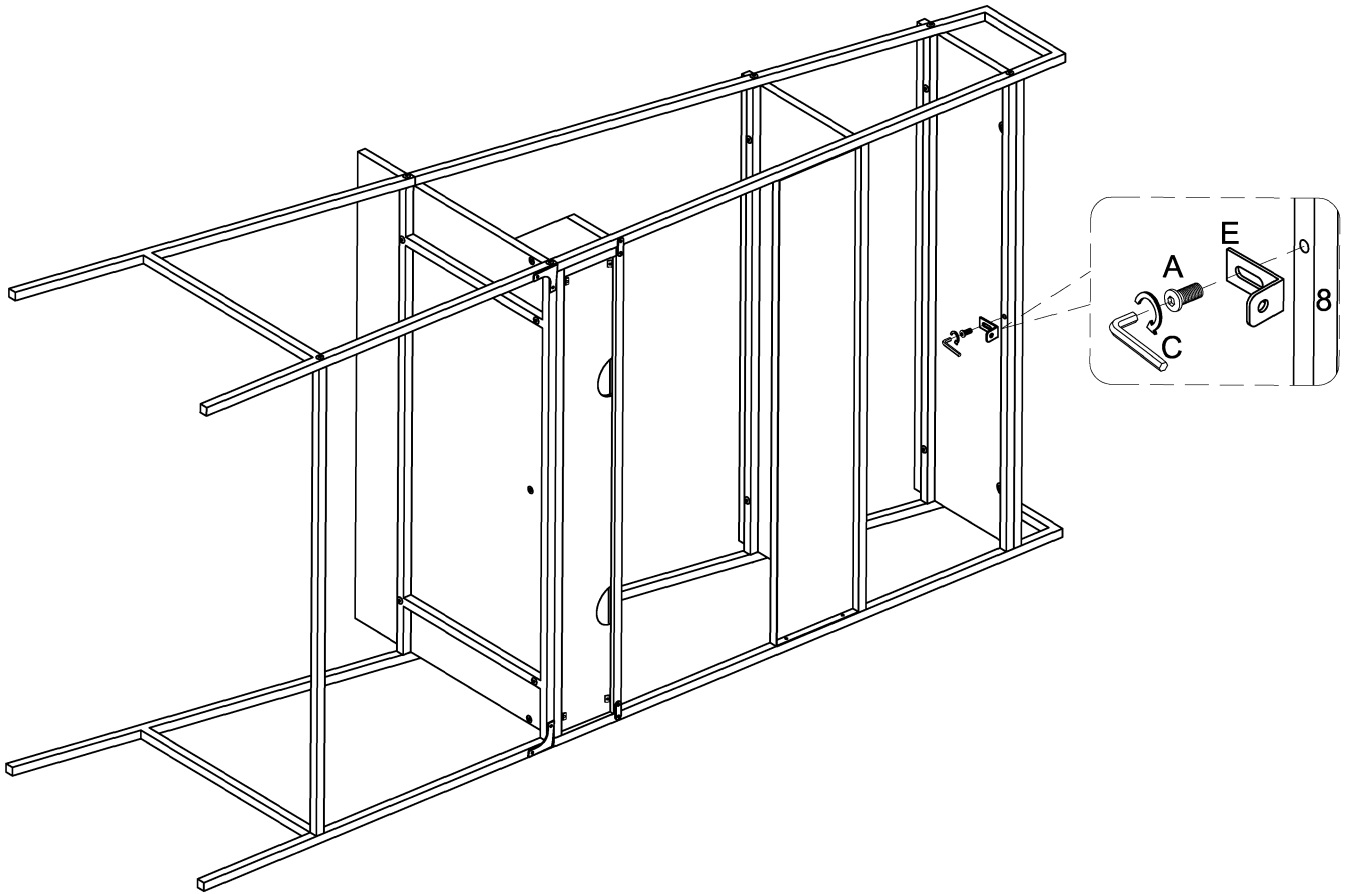

Attach bracket (E) to part (8) using bolt (A) with hex key (C).

Step 15

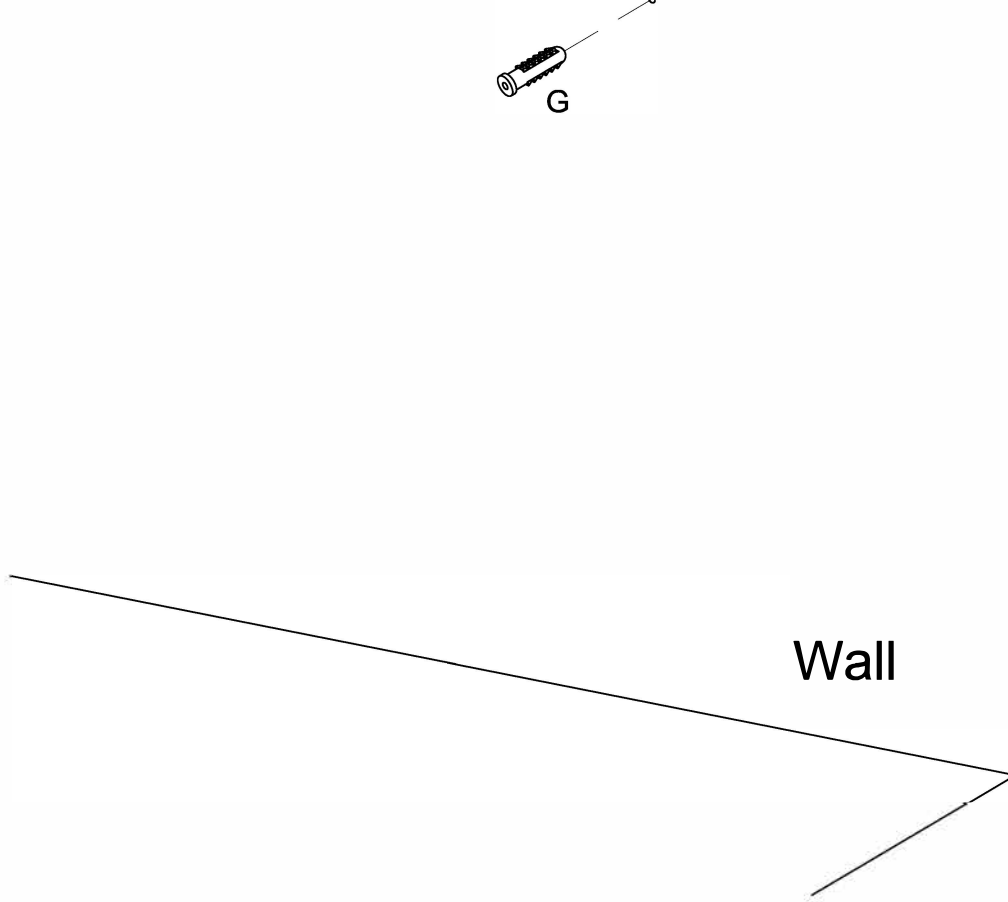
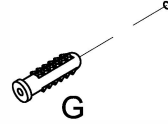
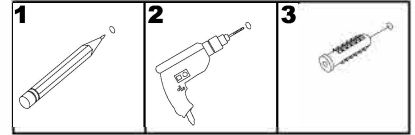

1. Measure height for bracket in desired location.
2. Drill hole using 6mm size bit.
3. Insert wall anchor (G) into wall at desired location.

*Wall anchor included for drywall mounting. Use correct wall anchor and hardware for your wall material.

Step 16



Secure furniture to wall anchor (G) in wall using washer (D) and screw (F) with screwdriver.

Step 17

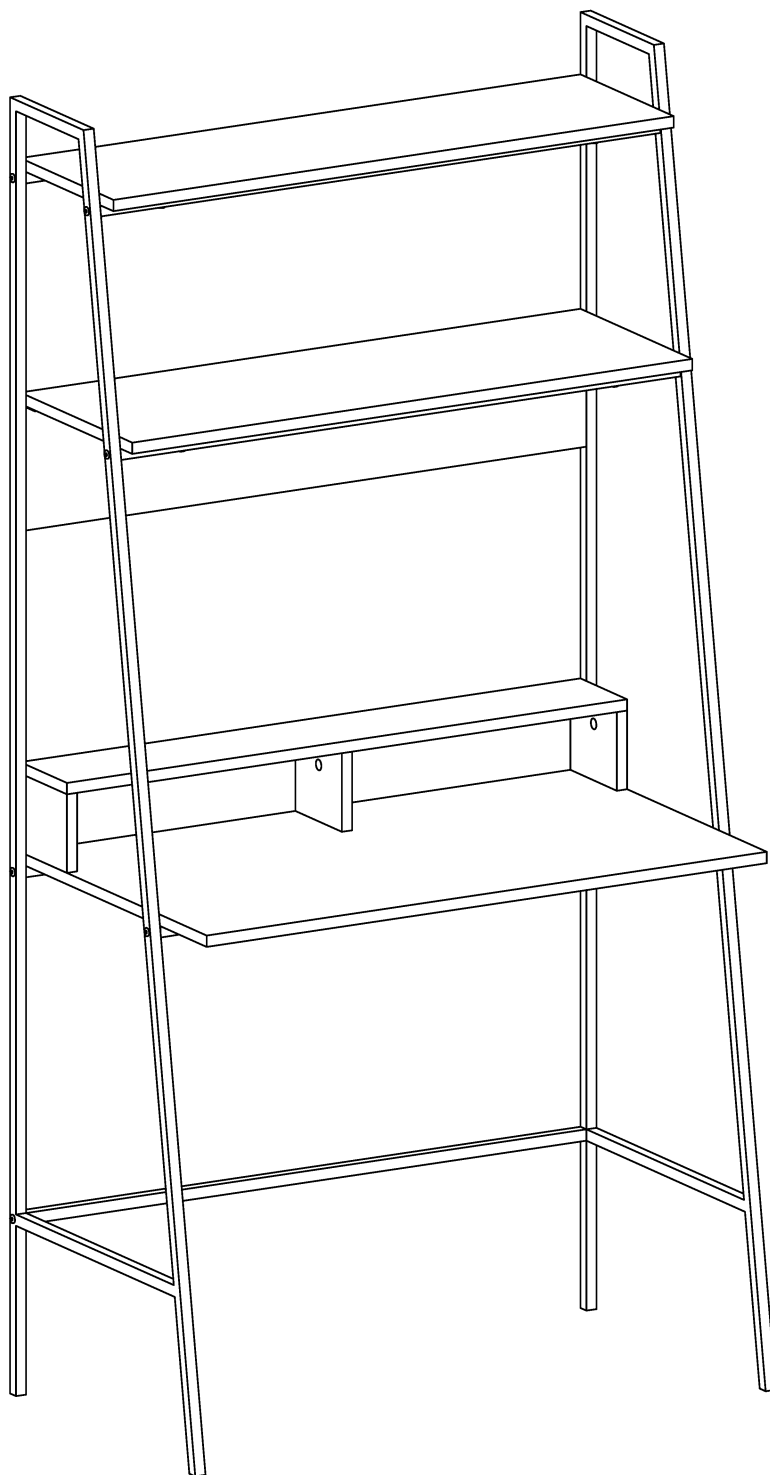

Final Assembly