

Adirondack Lounge Chair

If you have any questions about outdoor Adirondack chairs, please feel free to contact us.

Customer Service Email: Service@alaulm.com

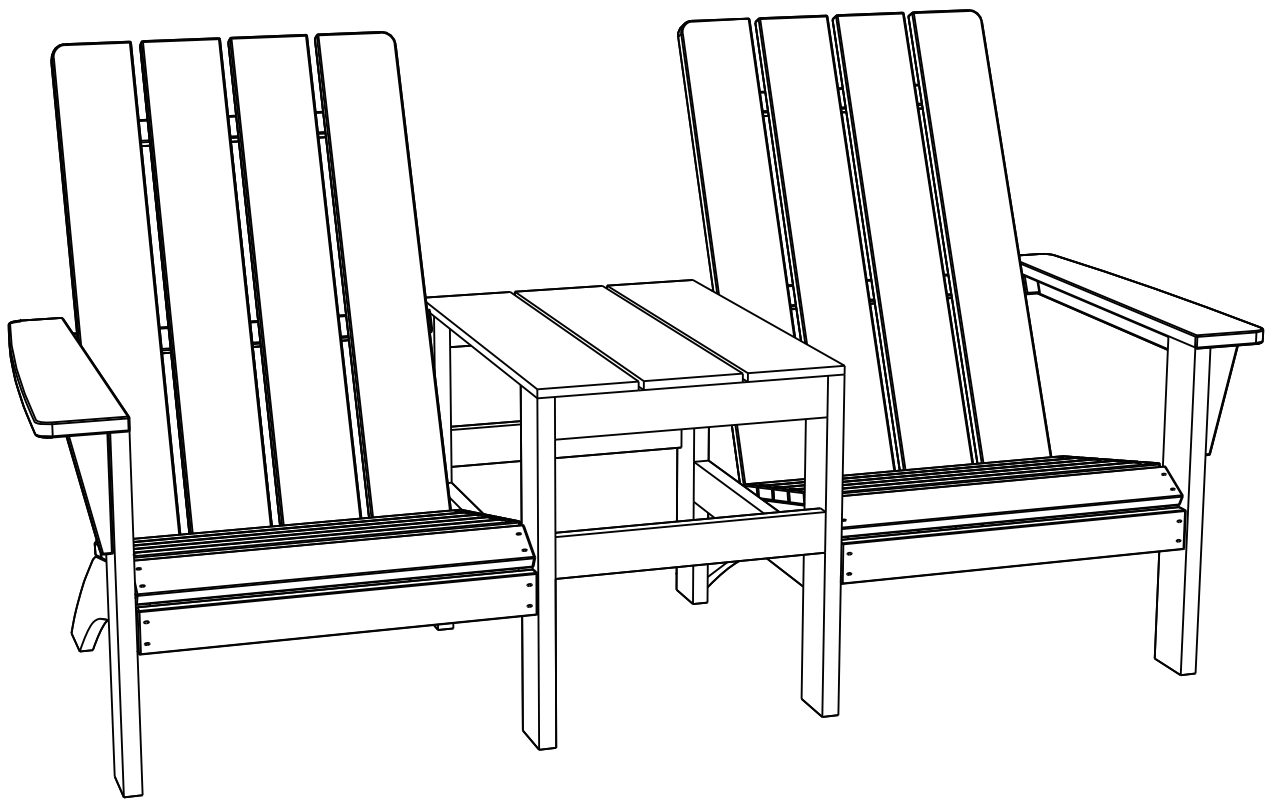

25-P042-B01

IMPORTANT

PLEASE READ BEFORE YOU COMMENCE ASSEMBLY

Follow the guidelines in this user guide to ensure correct assembly and care for this product.

Catalog

Specifications..... 02

Care & Instructions 04

Exploded Views 05

Parts List..... 06

Screw Set List.....08

Extra List.....08

How to Assemble Adirondack Chair.....09

SPECIFICATIONS

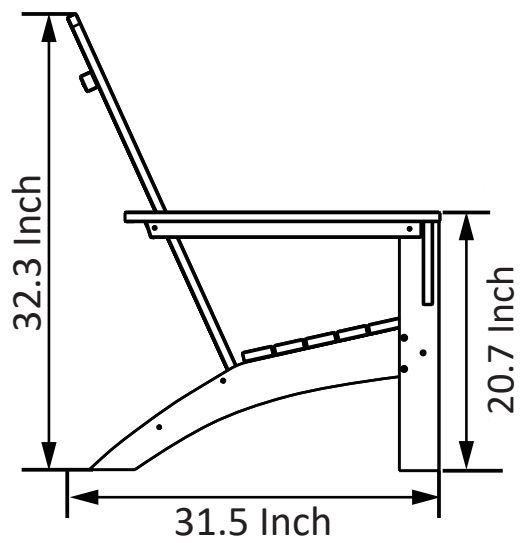
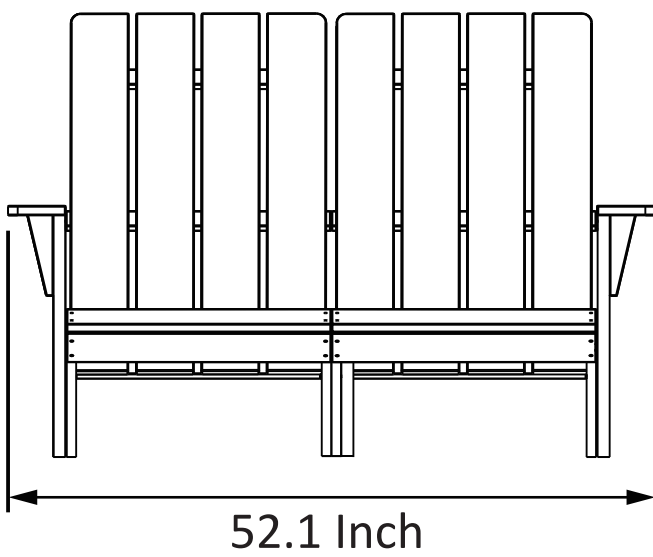
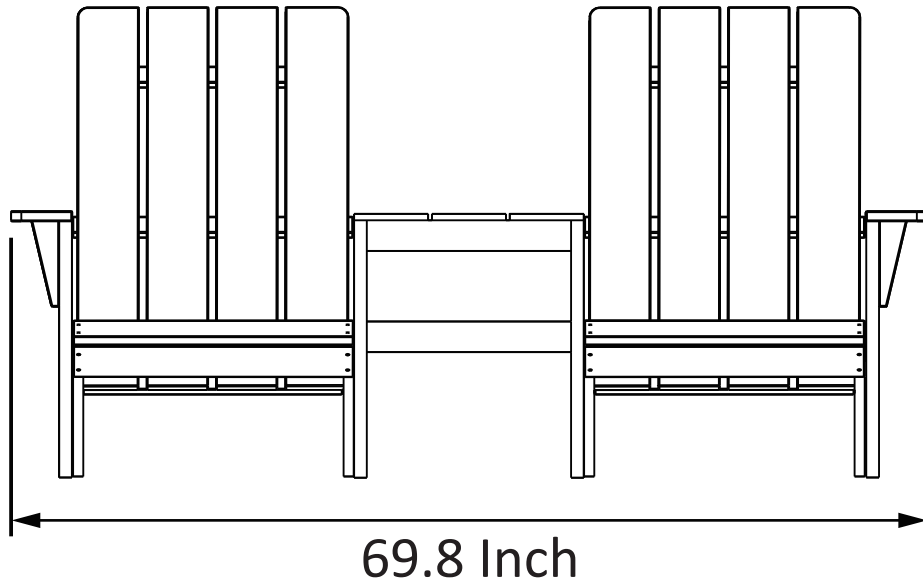

SPECIFICATIONS

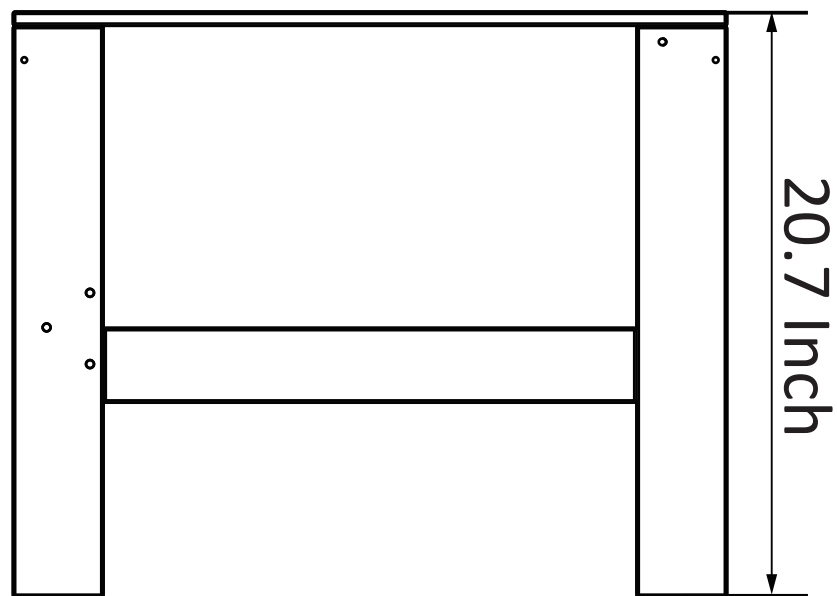
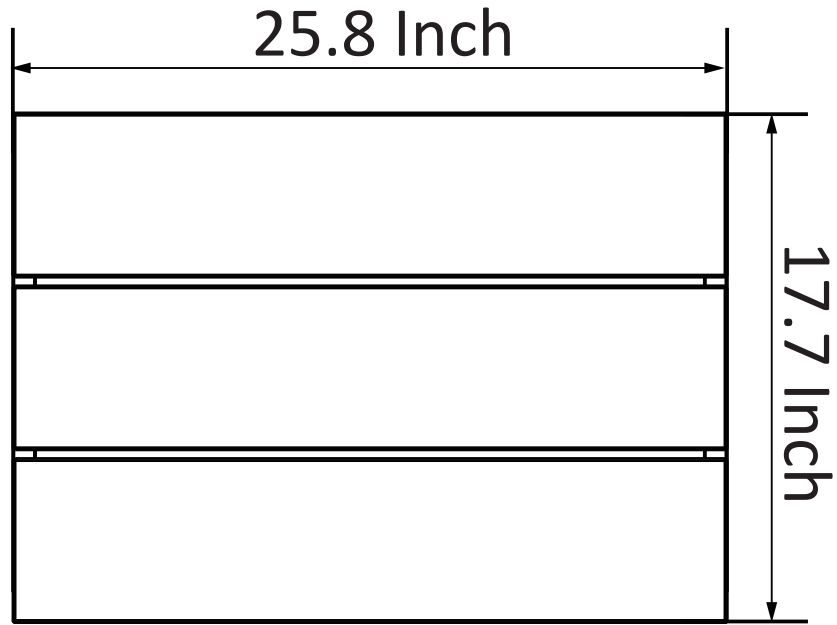

Care & Instructions

Thank you for ordering this Outdoor Adirondack Double Chair.

Here are some suggestions that may be helpful to you:

1. This outdoor Adirondack Double Chair contains one Adirondack loveseat and one rectangular coffee table per box.
2. If any parts are damaged or missing, please read these instructions carefully (see the parts list on page 6 and page 8) and feel free to contact us. We will replace them for you immediately.
3. We hope you can like our products, if you have any other questions, please contact us.

How to contact us:

Email:service@alaulm.com

Web:www.alaulm.com

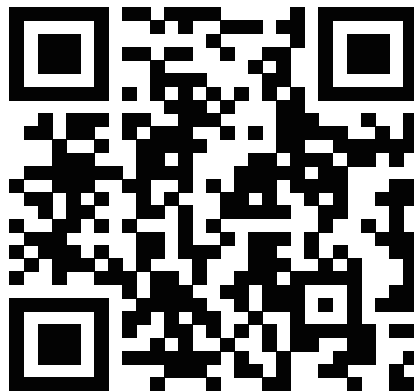

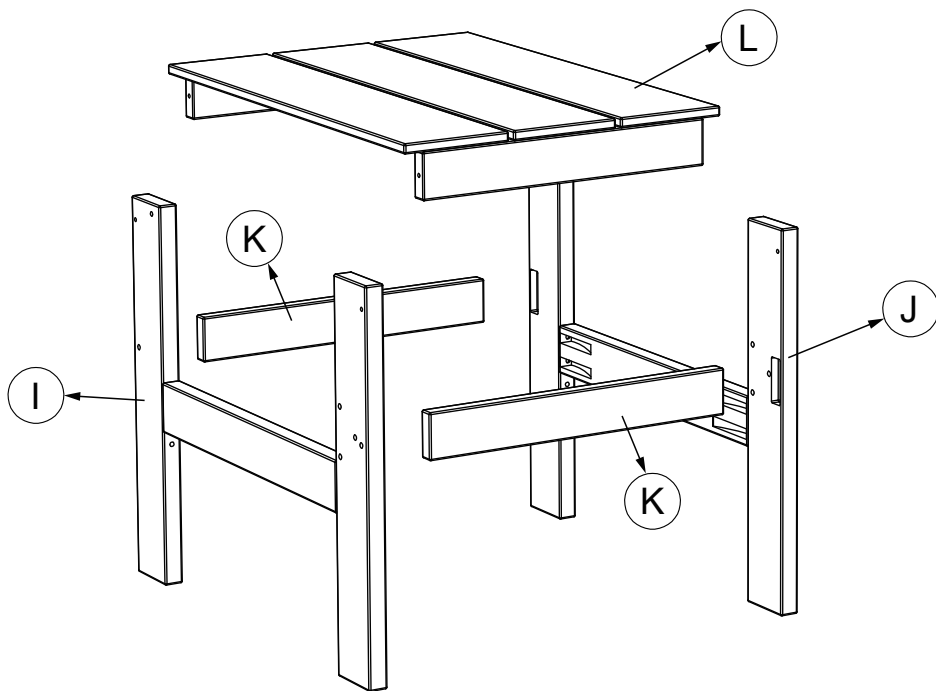
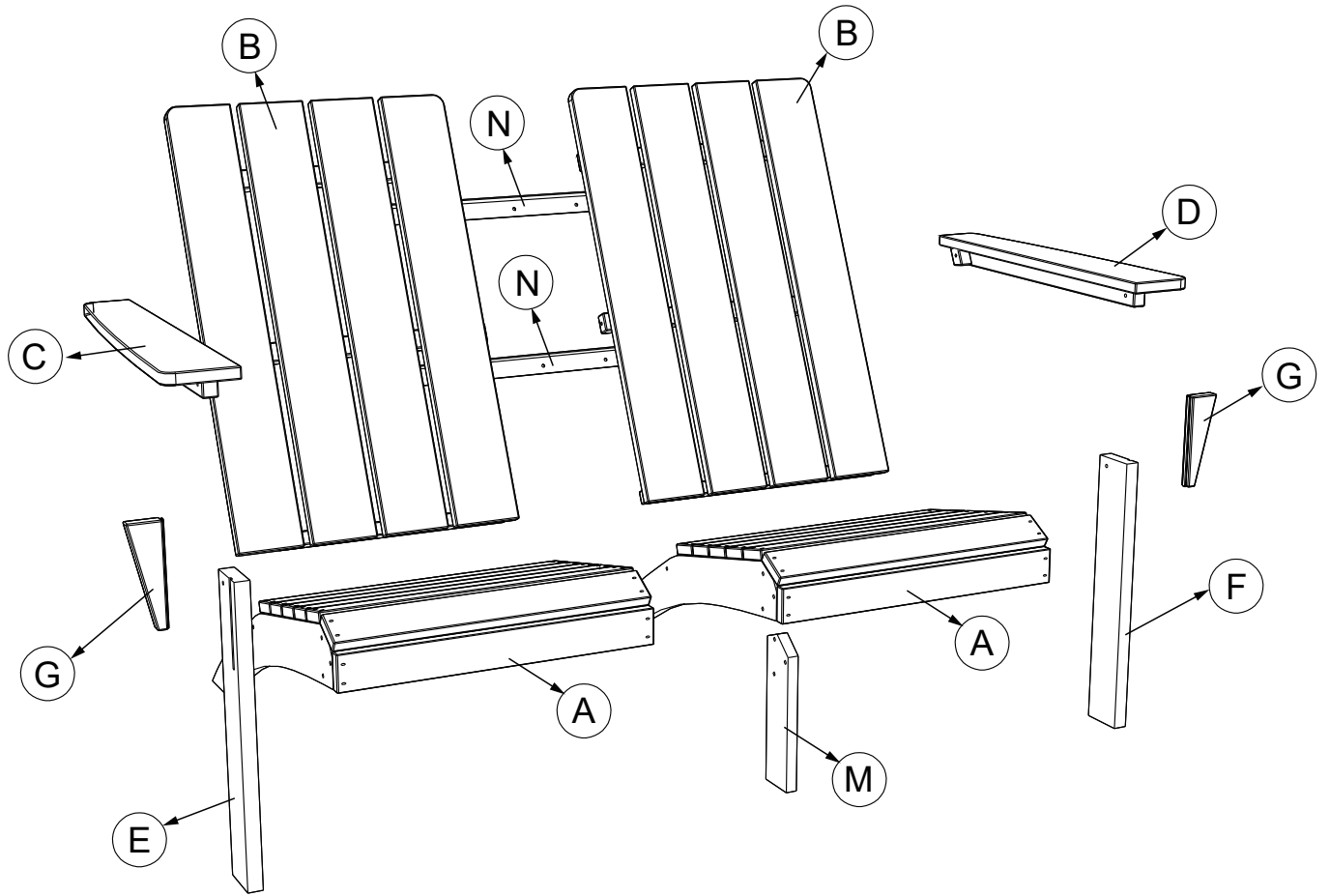

You can scan the QR code to explore more products.

EXPLODED VIEWS



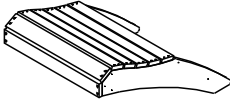
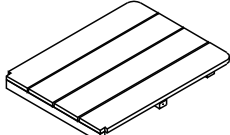
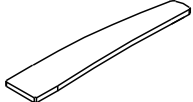
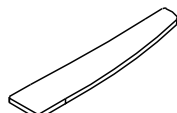
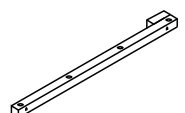
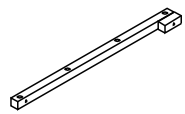
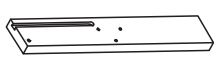
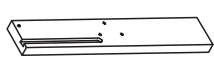





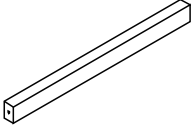
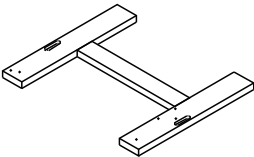
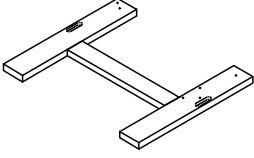
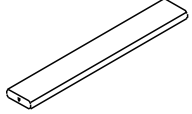
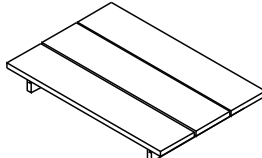
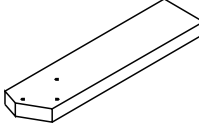
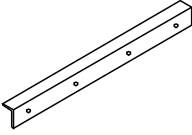

Packing List

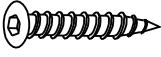
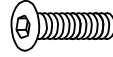
Part	Description	Part Name	Qty
A		Seat Plate	2
B		Back Plate	2
C		Right Armrest Plate	1
D		Left Armrest Plate	1
WR		Right Armrest Fixing	1
WL		Left Armrest Fixing	1
E		Right Foreleg	1
F		Left Foreleg	1
G		Triangular fixing	2







Packing List

Part	Description	Part Name	Qty
H		Connection Bar	2
I		Coffee Table Leg 1	1
J		Coffee Table Leg 2	1
K		Coffee Table Connector	2
L		Coffee Table Top	1
M		Middle Leg	1
N		Backrest Connector	2

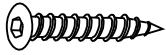
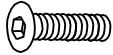
Screw Set A

Part	Description	Part Name	Qty
AA		Screw 6.3 × 50	16
BB		Bolt M6 × 20	8
CC		Bolt M6 × 40	10
DD		Bolt M6 × 55	15
EE		Bolt M6 × 60	2
FF		Bolt M6 × 70	5
GG		Nut	20
HH		Washer	20
JJ		T-Wrench	1
KK		Nut Wrench	1

Extra Screw Set

Part	Description	Part Name	Qty
AA		Screw 6.3 × 50	2
BB		Bolt M6 × 20	2
CC		Bolt M6 × 40	2
DD		Bolt M6 × 55	2
EE		Bolt M6 × 60	1
FF		Bolt M6 × 70	1
GG		Nut	3
HH		Washer	3

STEP 1

As shown in the figure, first align the seat plate (A) with the three holes on the side of the right foreleg (E), and use bolts (DD), spacers (HH) and nuts (GG) to assemble and tighten.

Note: The screw head is on the outside and the nut is on the inside for this process.

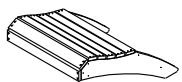
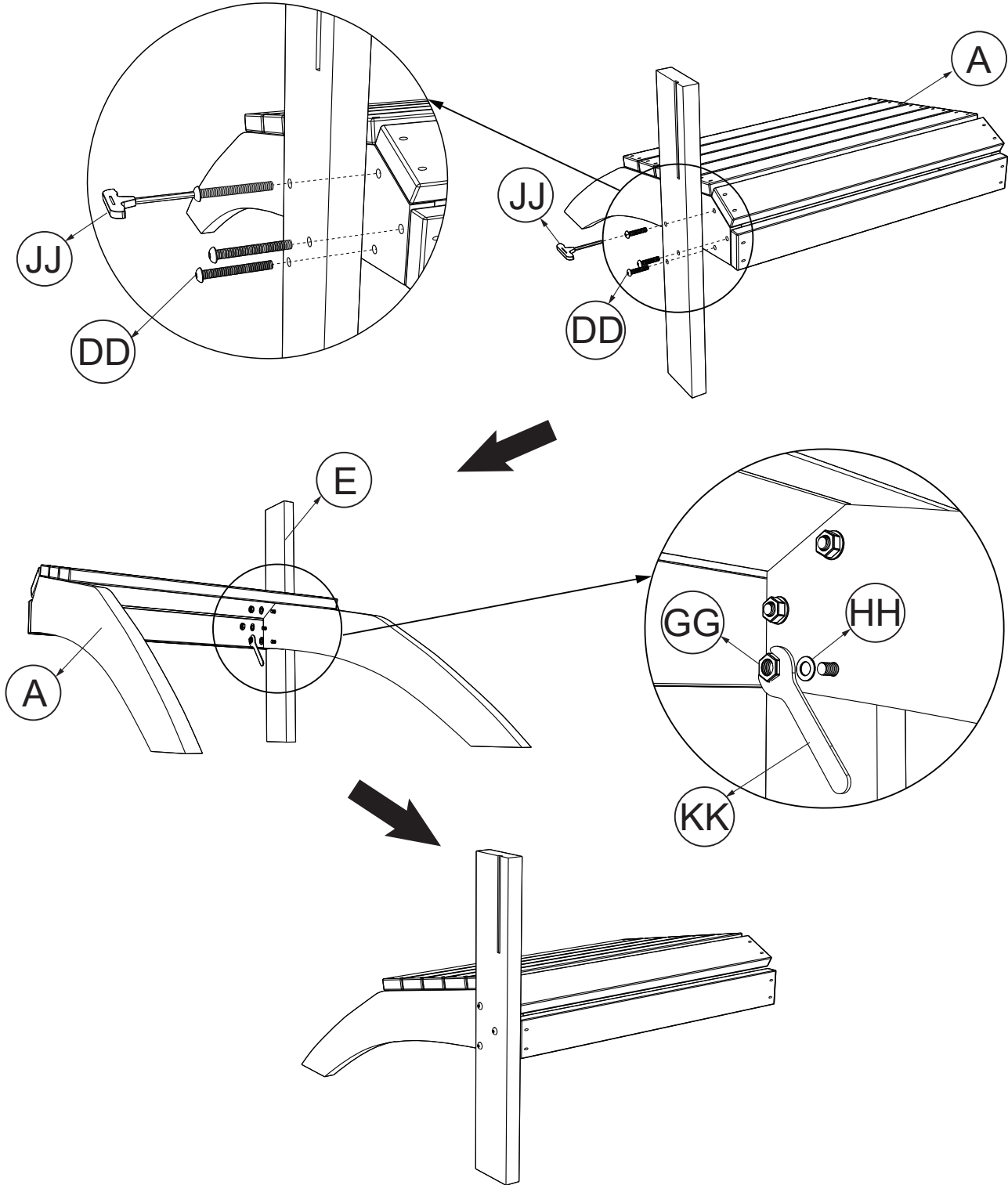

(A) × 1



(E) × 1



(DD) × 3



(GG) × 3



(HH) × 3

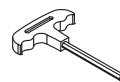

(JJ) × 1



(KK) × 1

STEP 2

As shown, connect the right armrest (C) with the Right Armrest Fixing (WR), use bolts (CC), and tighten it.

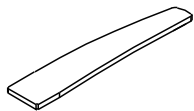
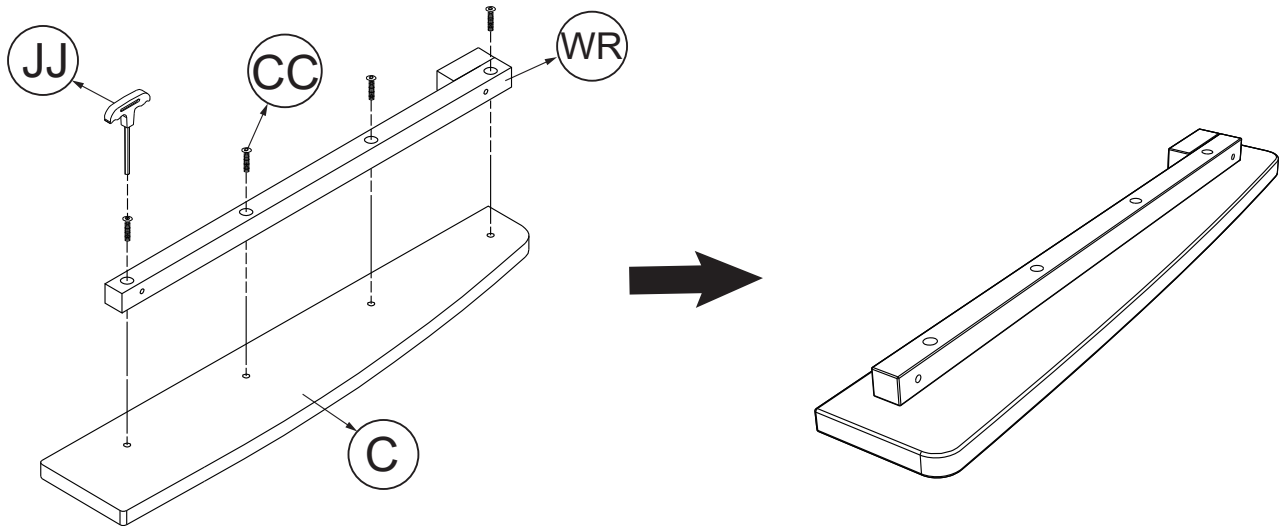

(C) × 1

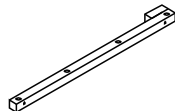

(WR) × 1



(CC) × 4



(JJ) × 1

STEP 3

As shown, Snap the triangular fixing (G) into the groove of the right foreleg (E).

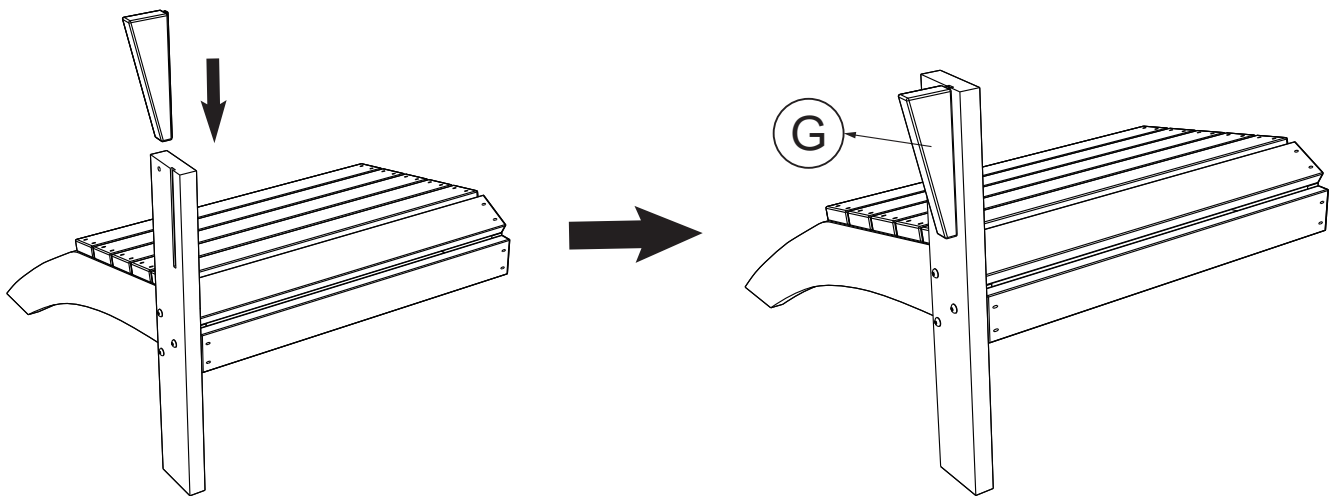





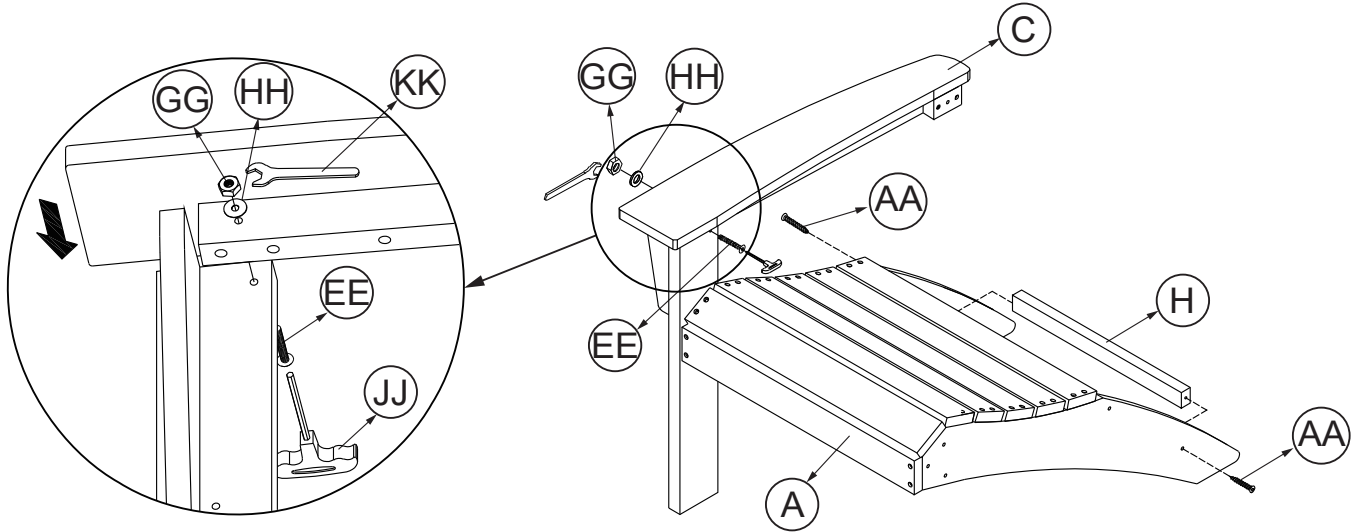

(G) × 1

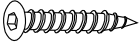
STEP 4

As shown in the figure, the installed right armrest is combined with the right front leg (E) and assembled with bolts (EE), spacers (HH) and nuts (GG).
Note: Do not tighten the bolt too tightly in this step.
 Then attach the connection bar (H) between the hind legs using screws (AA) and tighten it.

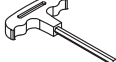

						
(H) × 1	(AA) × 2	(EE) × 1	(GG) × 1	(HH) × 1	(JJ) × 1	(KK) × 1

STEP 5

As shown in Fig. Attach the back plate (B) between the rears of the seat plate, align the holes behind the seat slats, and tighten them with screws (AA). Then align the middle hole of the back plate (B) with the hole on the back of the armrest, and tighten it with bolts (FF).
Note: The foreleg can be bolted to the armrest at this moment.

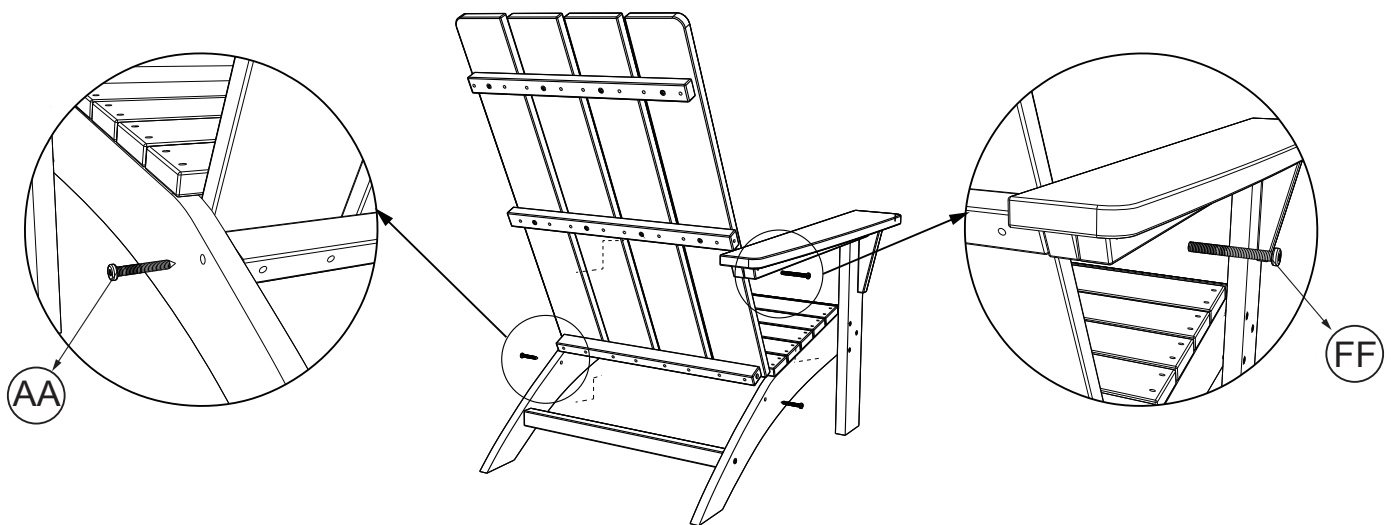

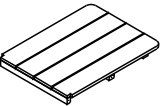
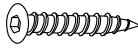
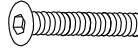
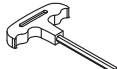
	(B) × 1		(AA) × 2		(FF) × 1		(JJ) × 1
---	---------	---	----------	---	----------	---	----------

STEP 6

As shown in the figure, first align the seat plate (A) with the three holes on the side of the left foreleg (F), and use bolts (DD), spacers (HH) and nuts (GG) to assemble and tighten.

Note: The screw head is on the outside and the nut is on the inside for this process.

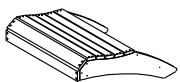
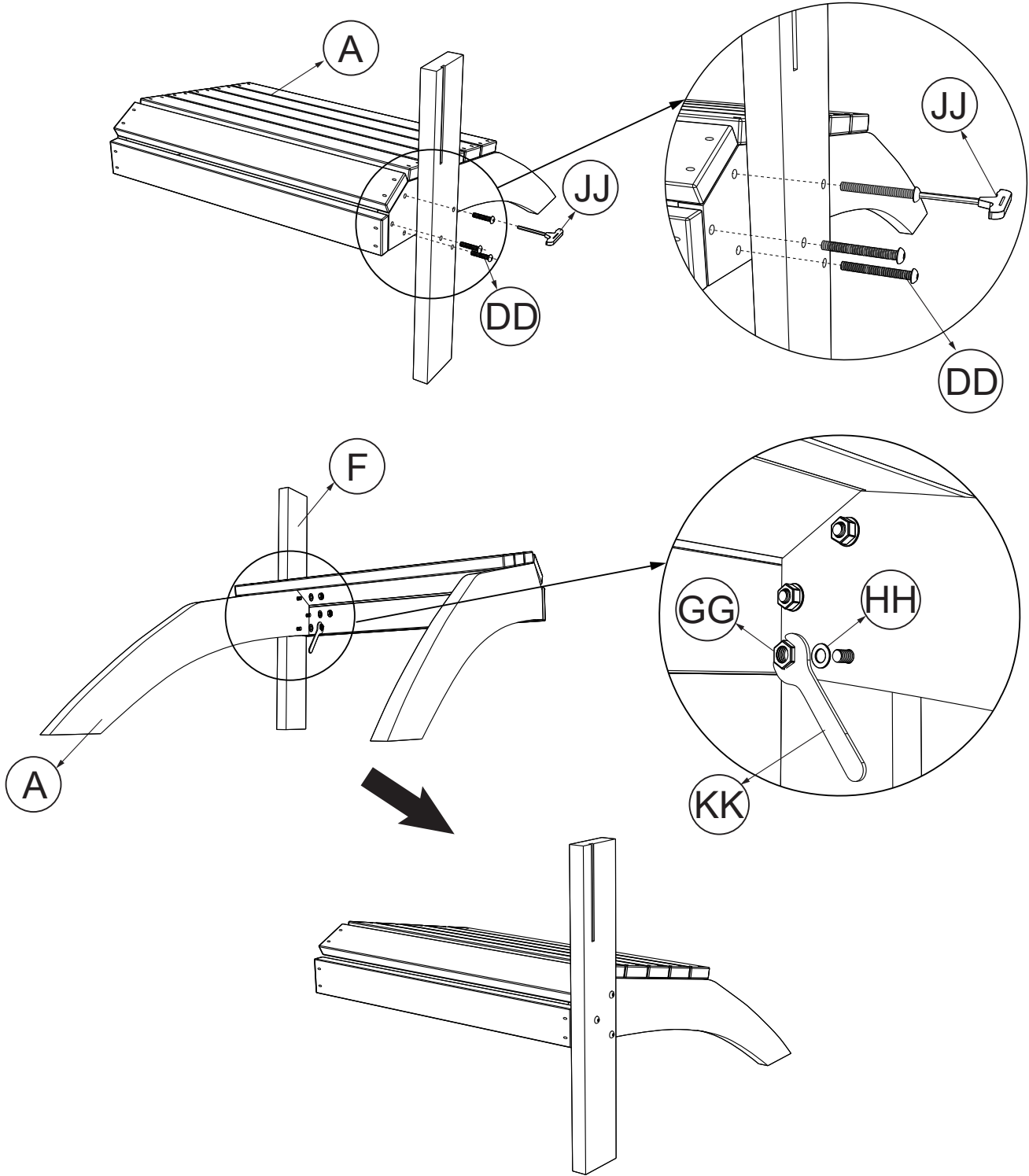

(A) × 1



(F) × 1



(DD) × 3



(GG) × 3



(HH) × 3

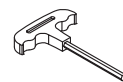

(JJ) × 1



(KK) × 1

STEP 7

As shown, connect the left armrest (D) with the left armrest fixing (WL), use bolts (CC), and tighten it.

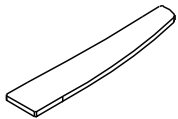
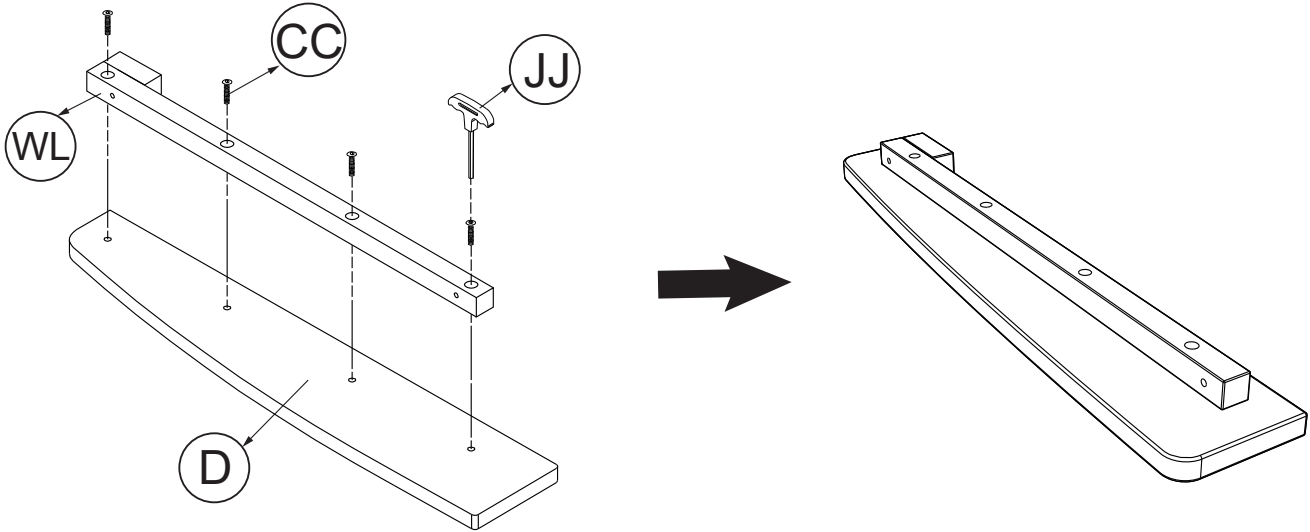

(D) × 1

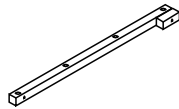

(WL) × 1



(CC) × 4

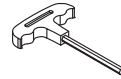

(JJ) × 1

STEP 8

As shown, Snap the triangular fixing (G) into the groove of the left foreleg (F).

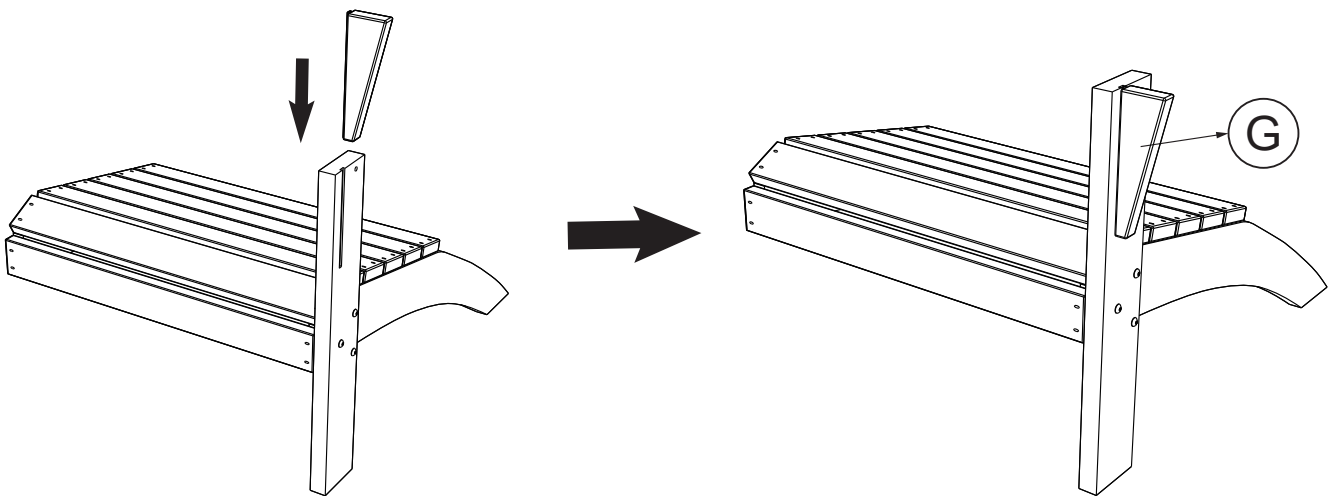

(G) × 1

STEP 9

As shown in the figure, the installed left armrest is combined with the left foreleg (F) and assembled with bolts (EE), spacers (HH) and nuts (GG).
Note: Do not tighten the bolt too tightly in this step.
 Then attach the connection bar (H) between the hind legs using screws (AA) and tighten it.

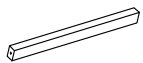
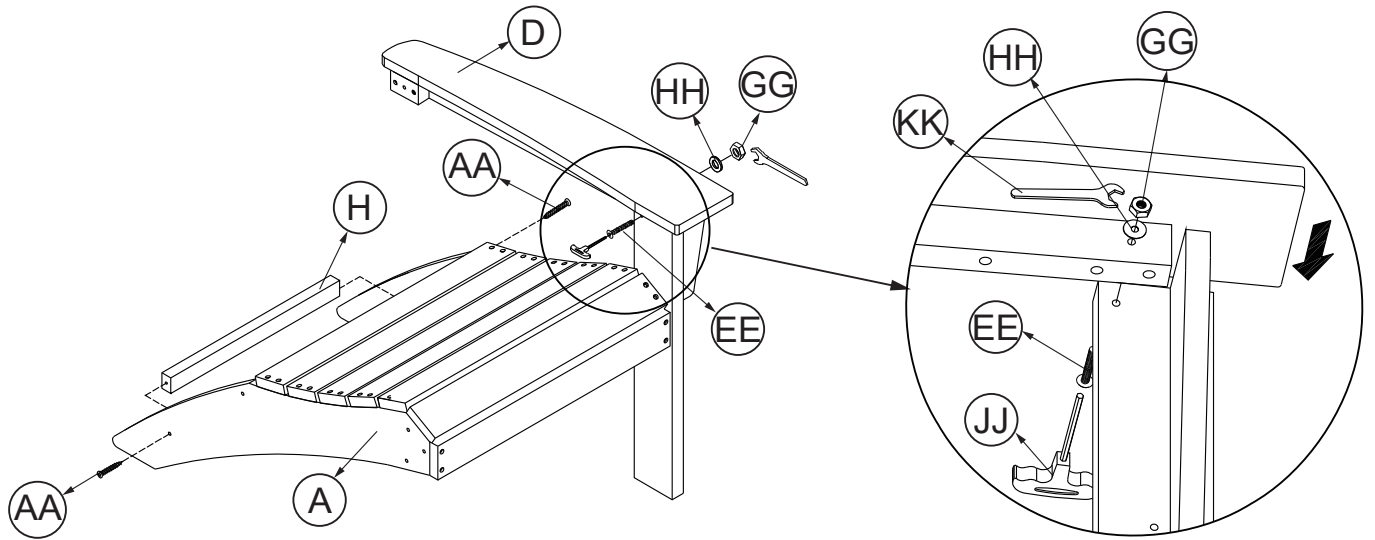

(H) × 1



(AA) × 2

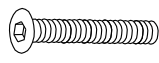

(EE) × 1



(GG) × 1



(HH) × 1

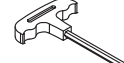

(JJ) × 1



(KK) × 1

STEP 10

As shown in Fig. Attach the back plate (B) between the rears of the seat plate, align the holes behind the seat slats, and tighten them with screws (AA). Then align the middle hole of the back plate (B) with the hole on the back of the armrest, and tighten it with bolts (FF).
Note: The foreleg can be bolted to the armrest at this moment.

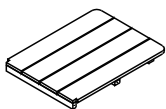
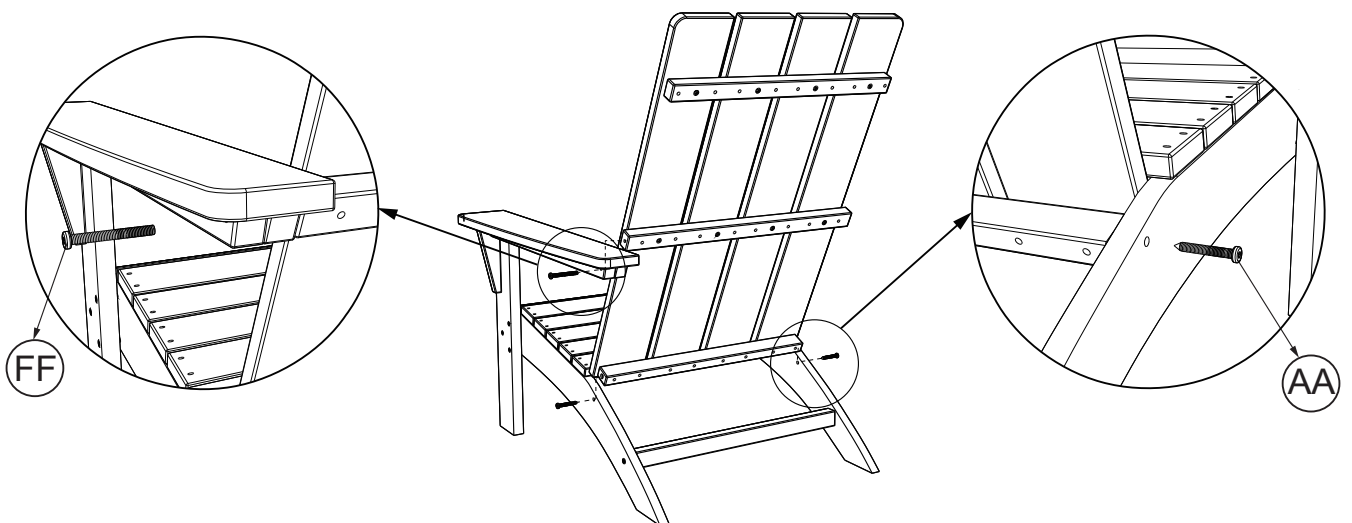

(B) × 1



(AA) × 2



(FF) × 1



(JJ) × 1

STEP 11

As shown in Fig. Insert the coffee table leg connecting rod (K) into the groove of the coffee table leg (I) and (J) and tighten it using screws (AA). Then install the coffee table surface (L) on the upper side of the coffee table leg, align the holes, and tighten it with screws (AA).

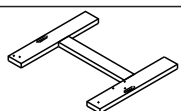
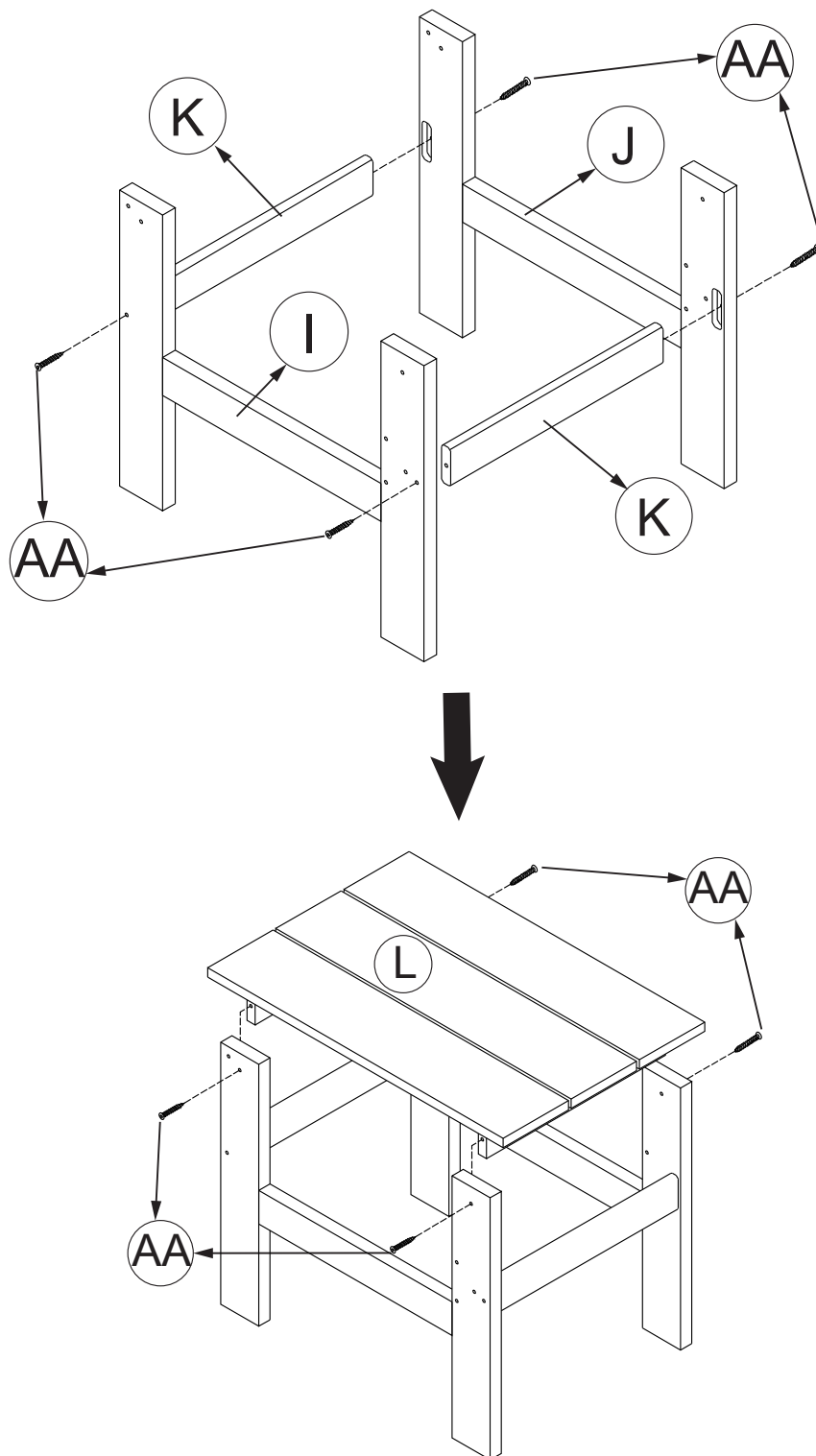

(I) × 1

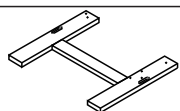

(J) × 1

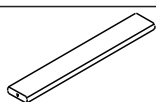

(K) × 2

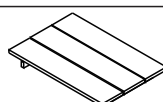

(L) × 1

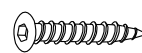

(AA) × 8

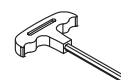

(JJ) × 1

STEP 12

The first combination. Place the coffee table in the middle of the left and right parts of the installed seat, align the three holes on the front side of the coffee table with the three holes on the side of the left and right seats, and tighten them with bolts (DD), nuts (GG) and gaskets (HH). Then align the hole of the middle connecting rod on the back to the empty space above the back leg of the middle coffee table, and use the bolt (CC) to tighten it from the inside.

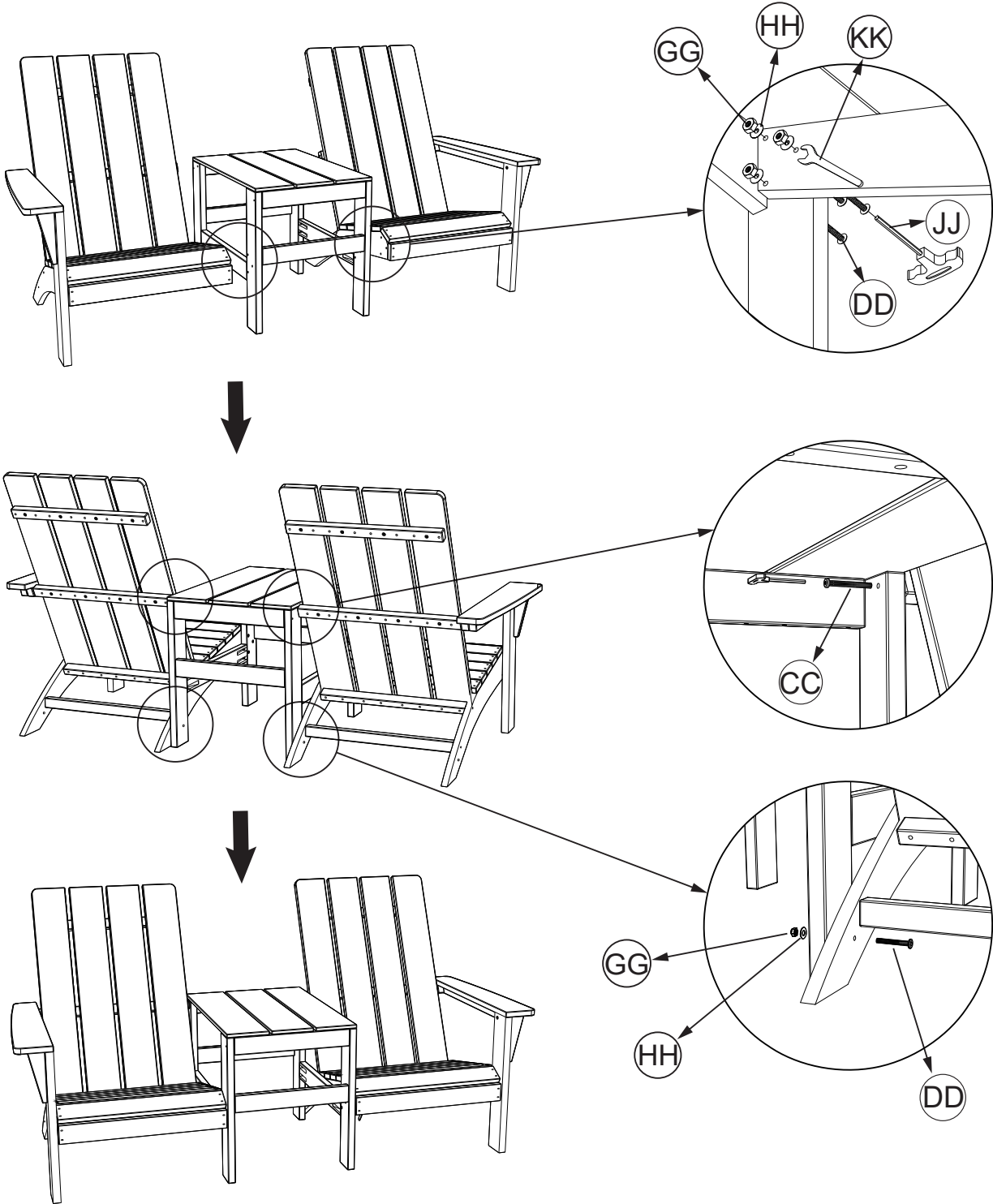

CC × 2



DD × 8



GG × 8



HH × 8



JJ × 1



KK × 1

STEP 13

The second combination. Align the left seat section with the armrestless side hole of the right seat part, place the middle foot (M) on the inside of the seat plate on either side, align the three holes with the side hole of the seat, and tighten it with the bolt (FF) nut (GG) and spacer (HH). Align the back connector (N) with the four holes in the middle of the backrest and tighten it with bolts (BB).

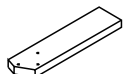
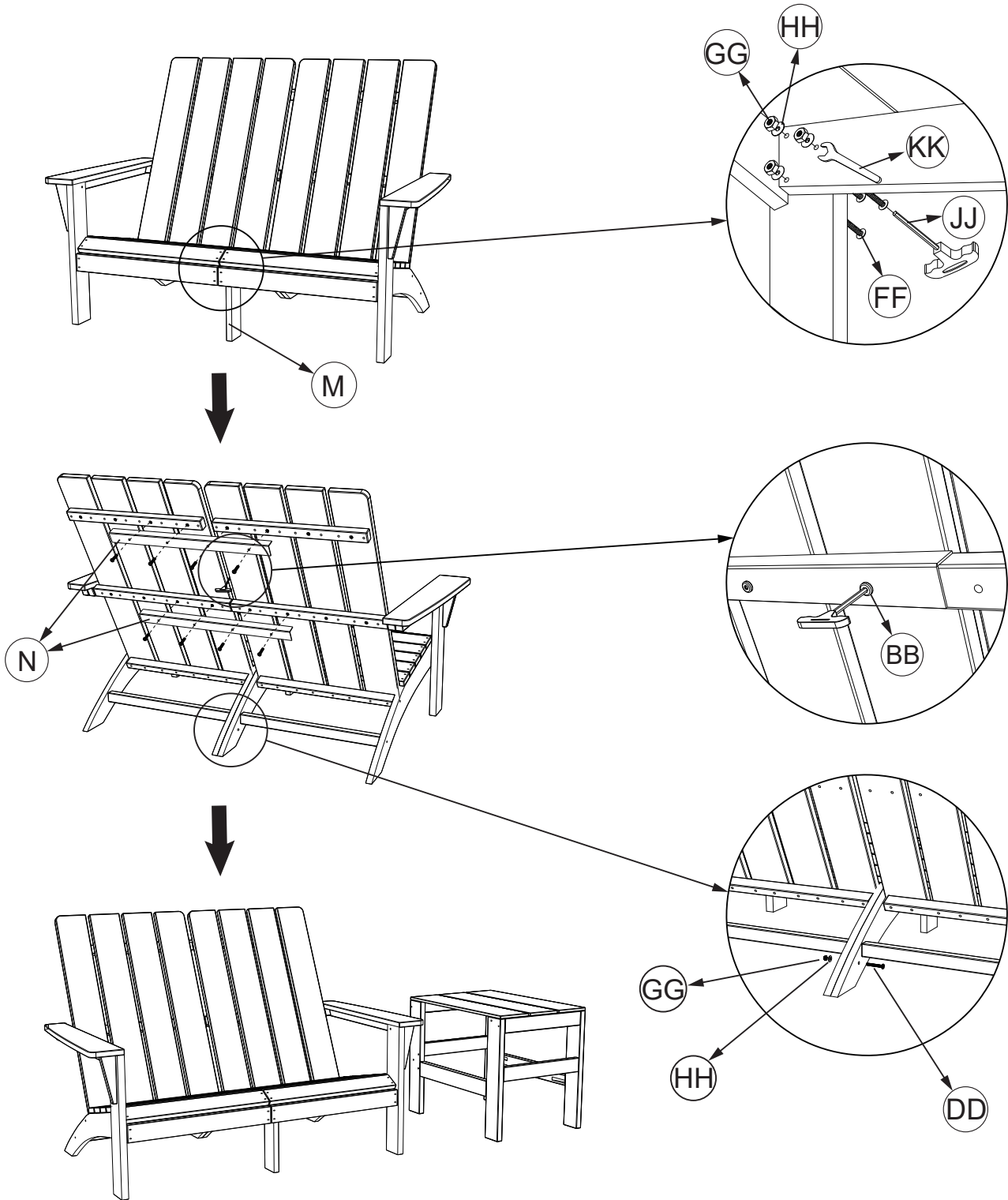

(M) × 1

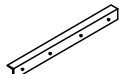

(N) × 2



(BB) × 8



(DD) × 1



(FF) × 3



(GG) × 4



(HH) × 4



(JJ) × 1



(KK) × 1

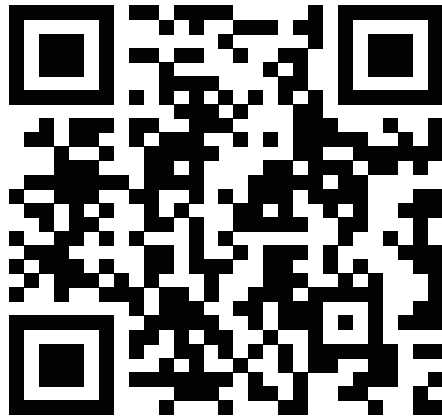

www.alaulm.com

Make your life much better.