

ASSEMBLY INSTRUCTIONS



Fine Furniture for every stage of life

HALL TREE

ASSEMBLY INSTRUCTIONS

ASSEMBLY TIPS:

1. Remove hardware from box and sort by size.
2. Please check to see that all hardware and parts are present prior to start of assembly.
3. Please follow attached instructions in the same sequence as numbered to assure fast & easy assembly.



WARNING!

1. Don't attempt to repair or modify parts that are broken or defective. Please contact the store immediately.
2. This product is for home use only and not intended for commercial establishments.

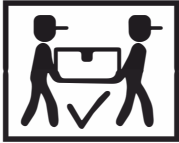

ASSEMBLY TIME

30 MINUTES

PARTS IDENTIFICATION

A LEGS 2PCS

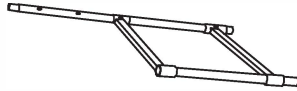

B TOP FRAME 1PC

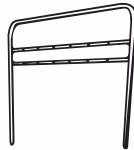

C BACK FRAME 1PC



D LEG FRAME 2PCS

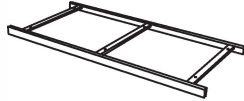

E HANGERS 6PCS









F CUSHION 1PC



G BOTTOM SHELF 1PC



Z HARDWARE IDENTIFICATION

	DESCRIPTION	FIGURE	Q'TY
1	SHORT BOLT (M6X12MM)		4PCS
2	MEDIUM BOLT (M6X25MM)		12PCS
3	LARGE BOLT (M6X40MM)		4PCS
4	EXTRA LARGE BOLT (M6X50MM)		8PCS
5	SCREW (4X25MM)		12PCS
6	PLASTIC CAP		4PCS
7	ALLEN WRENCH (M4)		1PC

ASSEMBLY INSTRUCTIONS

STEP 1

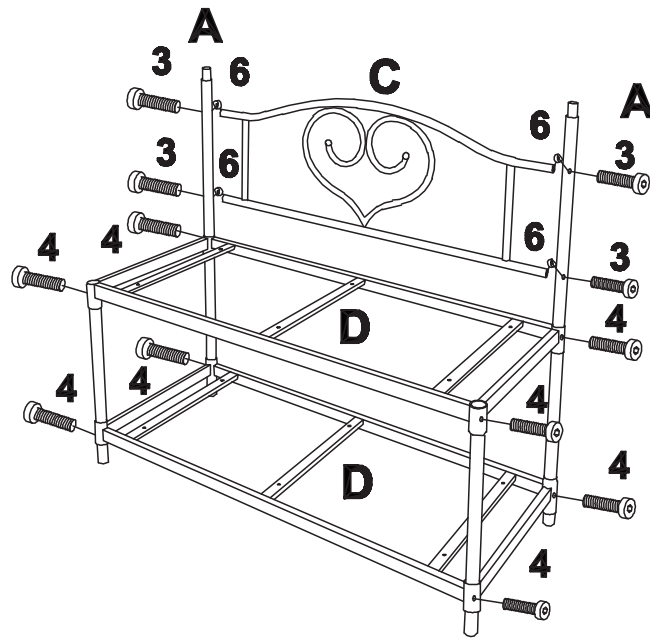

STEP 2

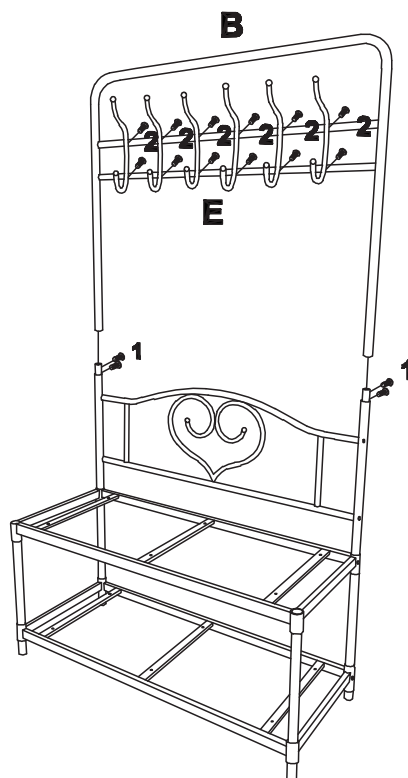

ASSEMBLY

INSTRUCTIONS

STEP 3

