



INSTRUCTIONS D'ASSEMBLAGE
ASSEMBLY INSTRUCTIONS

**TABLE D'APPOINT -
FAUX BOIS NOIR / METAL NOIR**

**ACCENT TABLE -
BLACK RECLAIMED WOOD-LOOK / BLACK METAL**



**POUR DE L'ASSISTANCE OU POUR COMMANDER
DES PIÈCES CONTACTEZ NOTRE DÉPARTEMENT
DE SERVICE À LA CLIENTÈLE**

LISTE DES PIÈCES PARTS LIST

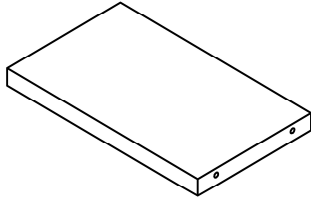
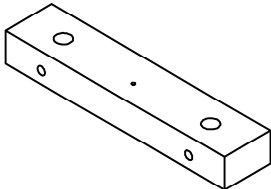
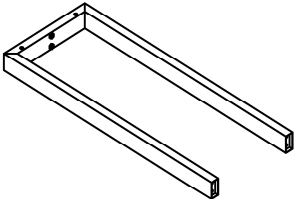
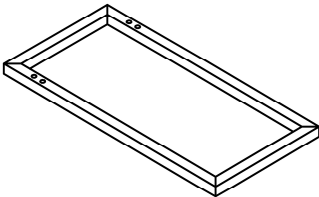
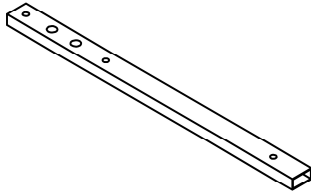
PIÈCE / PART #	IMAGE	DESCRIPTION	QTY / QTÉ
1		TABLE TOP (LARGE) DESSUS DE TABLE (GRAND)	1
2		TABLE TOP (SMALL) DESSUS DE TABLE (PETIT)	1
3		METAL LEG PATTE EN METAL	1
4		METAL LEG FRAME CADRE EN MÉTAL	1
5		SUPPORT BAR BARRE DE SOUTIEN	1

LISTE DES PIÈCES DE MONTAGE HARDWARE LIST

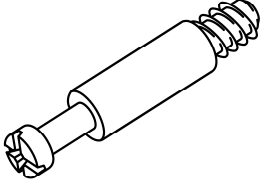
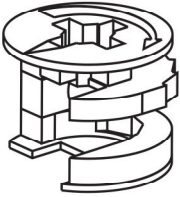
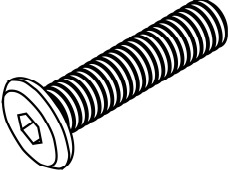
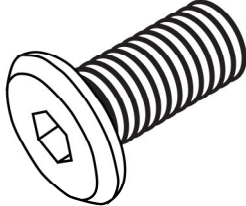
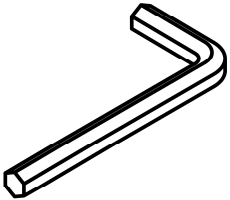
PIÈCE / PART #	IMAGE	DESCRIPTION	QTY / QTÉ
A		CAM LOCK SCREW - 1/4" X 1 1/4" VIS CAM LOCK - 1/4" X 1 1/4"	4
B		CAM LOCK CONNECTOR - Ø5/8" X 1/2" ÉCROU CAM LOCK - Ø5/8" X 1/2"	4
C		ASSEMBLING BOLT - 1/4" X 1 1/2" BOULON D'ASSEMBLAGE - 1/4" X 1 1/2"	4
D		ASSEMBLING BOLT - 1/4" X 1" BOULON D'ASSEMBLAGE - 1/4" X 1"	2
E		HEX KEY CLÉ HEXAGONALE	1

LISTE DES PIÈCES DE MONTAGE
HARDWARE LIST

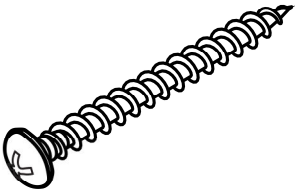
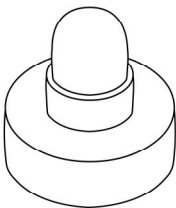
PIÈCE / PART #	IMAGE	DESCRIPTION	QTY / QTÉ
F		ASSEMBLING SCREW - Ø1/8" X 1 1/8" VIS D'ASSEMBLAGE - Ø1/8" X 1 1/8"	3
G		FLOOR PROTECTOR PROTECTEUR DE PLANCHER	4



**OUTIL DE VÉRIFICATION DE DIMENSIONS DES PIÈCES
HARDWARE DIMENSIONS VERIFICATION TOOL**



ÉTAPE / STEP 1

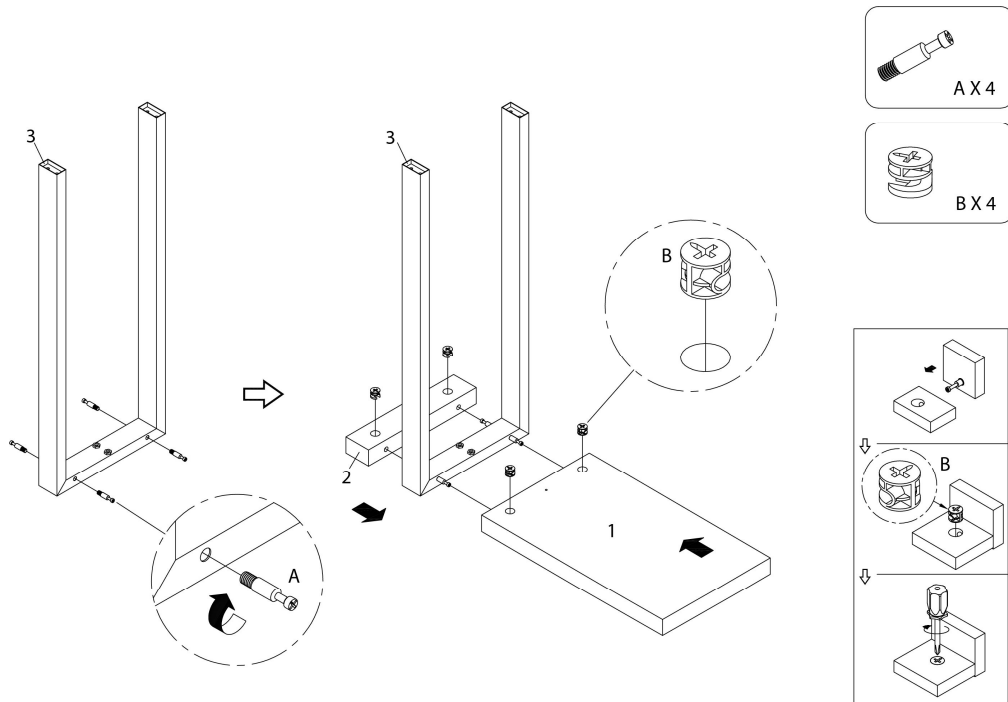

ÉTAPE / STEP 2

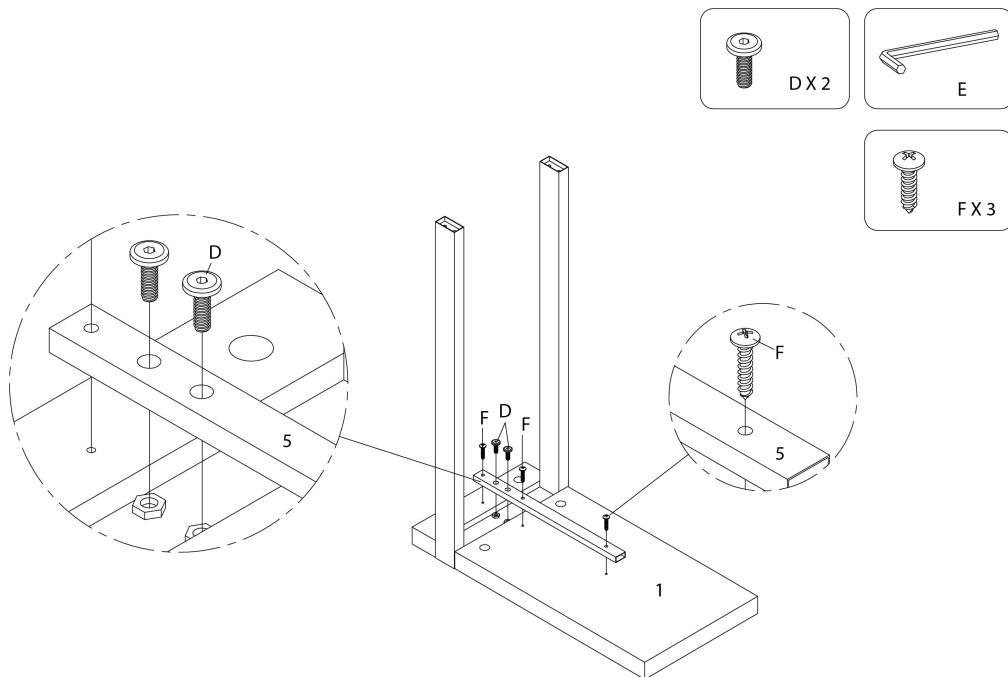

ÉTAPE / STEP 3

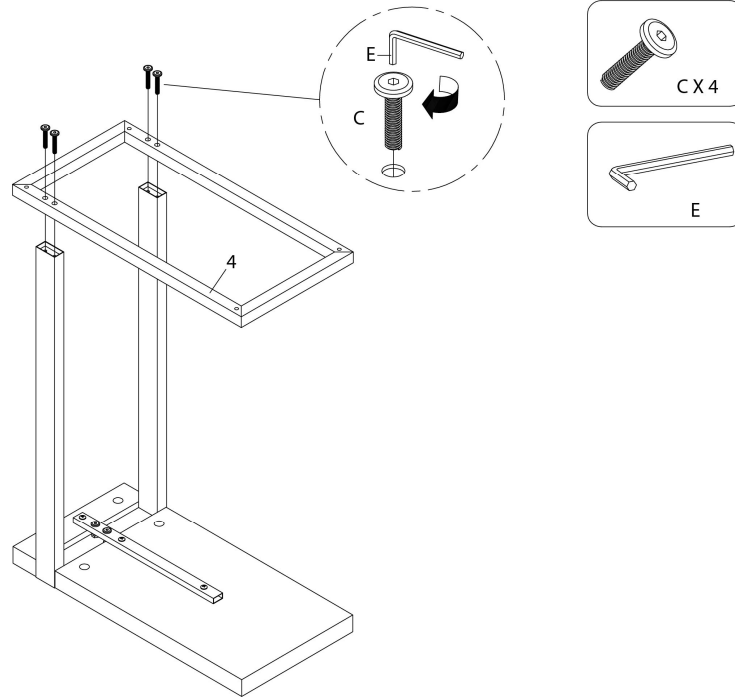

ÉTAPE / STEP 4

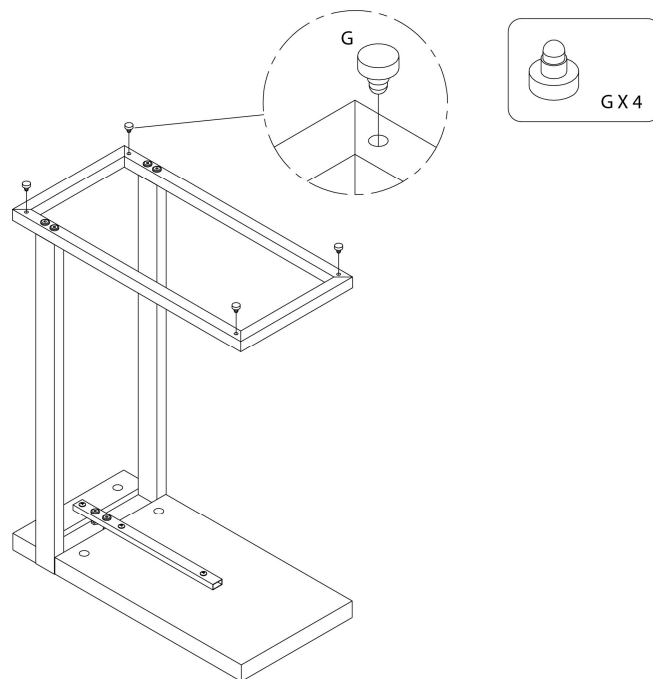

ÉTAPE / STEP 5

