

1

Tighten the screws clockwise with hex key.

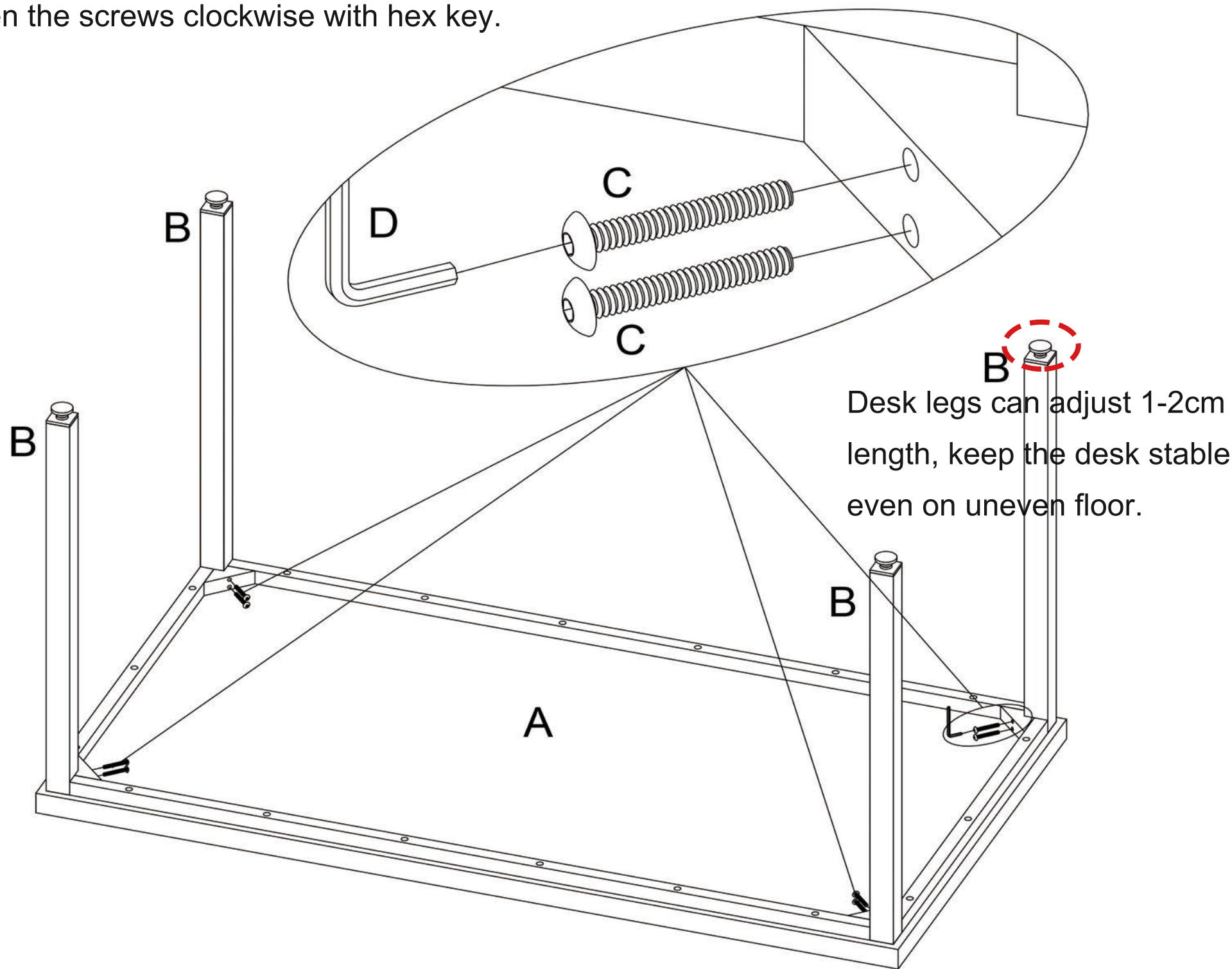

The trick to make this table more sturdy:

Step 1: Place the top upside down on the floor and screw in the bolts until they both have some resistance.

Step 2: Tighten them a little bit at a time alternating bolts. Once both the bolts are tight hold the end of the leg and push and pull it back and forth. You will find the bolts are now loose.

Step 3: Tighten the bolts again as before and repeat to get to the point where pushing and pulling the leg no longer loosened the bolts. At that point the leg was very solidly attached.

2

**NO.1. Installation adjustment & Using**

\*Installation adjustment

Setup: See more installation manual

\*Using

Placed away from direct light exposure, or use curtains to separate sunlight. High intensity daylight will make furniture paint film fade, metal parts are easily oxidized and deteriorated.

\*Safety Matters

1. Please using thermal pad when placed over 60 degrees Celsius high temperature objects.
2. Do not let children play near the furniture sharp angle, mirror, metal and other parts.

**NO.2. Handling & Storage**

\*Handling

- 1: Using both hands during handling gently, do not be rude, do not move furniture reluctantly without enough manpower.
- 2: Do not push the furniture, should lift and move.
- 3: Lifting the table legs and do not lift the desktop when handling the desk.
- 4: Drawers and doors should be fixed to avoid tilting or vibrating.

\*Storage

- 1: The furniture needs to be placed in dry and ventilated place, do not store in wet, exposure and rainy environments
- 2: Do not use plastic film wrap when storing, and avoid moisture from the plastic film to cause furniture paint film whitening

**NO.3. Maintenance**

\*Daily maintenance

Use clean soft cloth and neutral detergent to wipe the surface dust. (Do not use acid and alkaline chemicals)

\*Regular maintenance

Maintenance once every six months, using a small amount of oil to apply and wipe the metal parts to make flexible and prevent rust and oxidation.

**NO.4. Failure Analysis & Troubleshooting**

Symptom	Reason	Solution
Door gap leads to unusable use	Furniture did not put flat	adjust the position or pad with
Parts loose	Transportation cause	Tighten hinges or screws