

Step 5

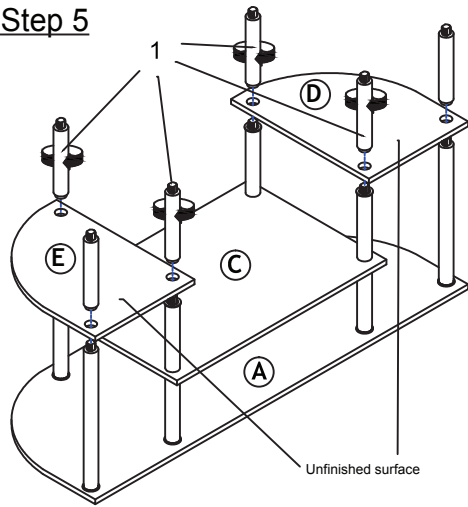

Step 6

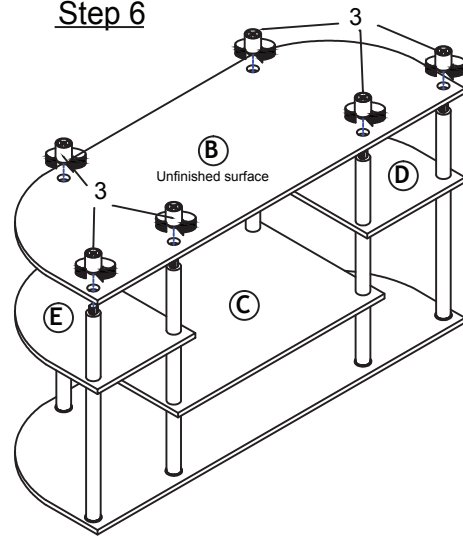

Recommended Maximum Weight

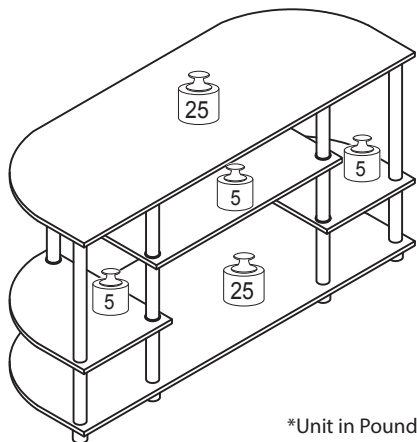

WARNING:

>This unit has been designed to support the maximum loads shown. Exceeding these load limits could cause sagging, instability, product collapse, and/or serious injury.

>DO NOT allow children to climb on unit.

>Put heavier items on lower shelves.

Assembly Instruction

Corner TV Stand

00:30

Approx. 30 minutes









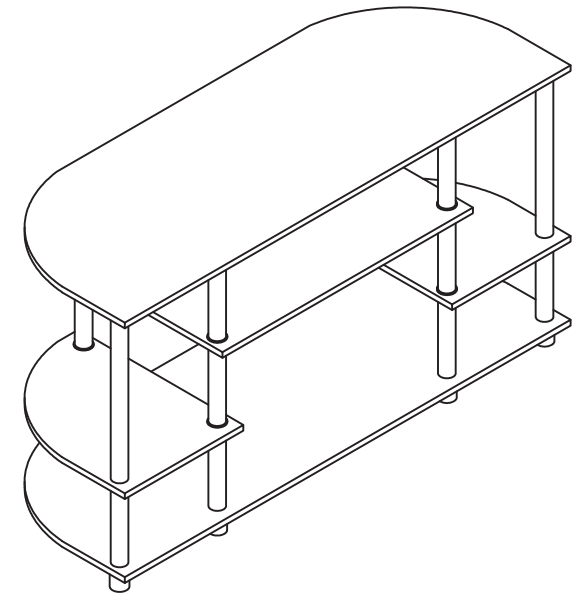

Recomm. 1 Person



No Tools Required



No	Hardware List	Qty
1	Short Round Pole 	14pcs
2	Round Pole 	2pcs
3	Round Leg 	6pcs
4	PVC Round Ring 	8pcs

No	Parts List	Qty
A	Top Panel 	1pc
B	Bottom Panel 	1pc
C	Center Shelf Panel 	1pc
D	Left Shelf Panel 	1pc
E	Right Shelf Panel 	1pc

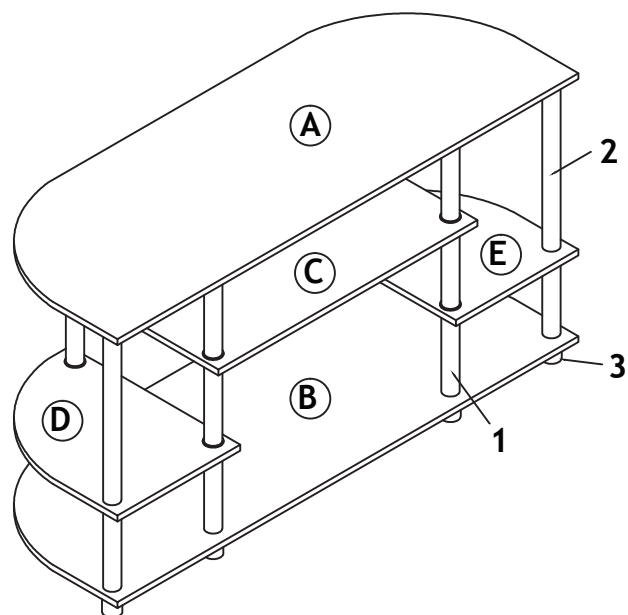

USEFUL HINTS BEFORE YOU START:

1. Read each step carefully before starting.
2. It is important that each step is performed in correct order to avoid difficulties.
3. Identify, sort and count the parts before assembly.
4. Assemble your furniture on packaging cardboard to prevent scratch or damage.
5. Clean the product with mild cleanser using soft damped cloth. Do not use harsh or abrasive cleanser.
6. Using incompatible hardware might cause damage to product.

ASSEMBLY INSTRUCTION

Step 1

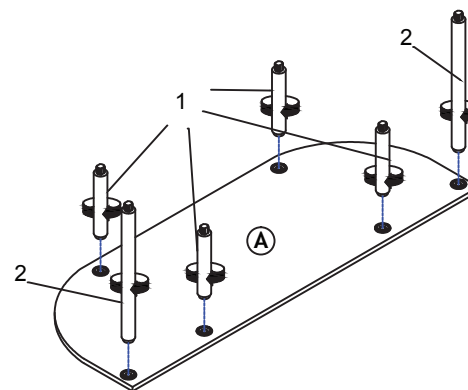

Step 2

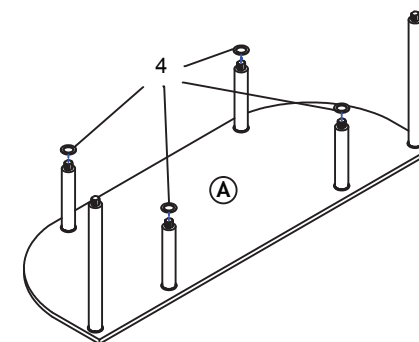

Step 3

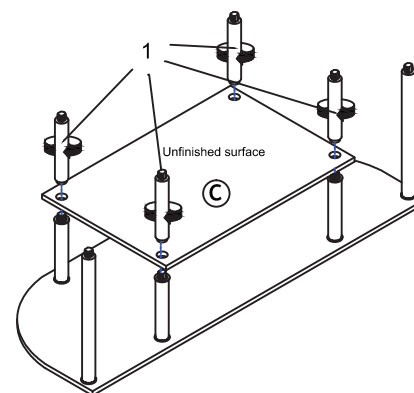

Step 4

