

Assembly Instructions

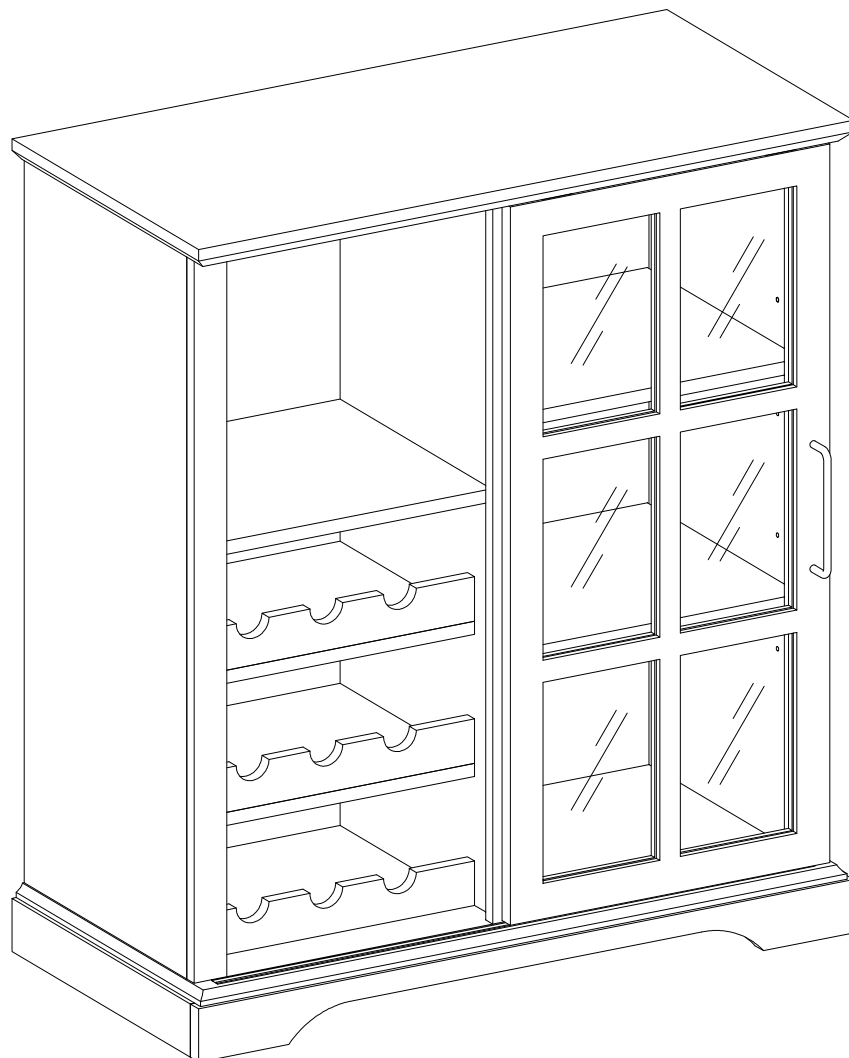

General Assembly Guidelines

- I. Ensure that all parts and hardware are available before beginning assembly.
- II. Follow each step carefully to ensure the proper assembly of this product.
- III. Two people are recommended for ease in the assembly of this product.
- IV. The three main types of hardware used to assemble this product are: wood dowels, screws and bolts.
- V. The provided glue is to secure wood dowels in place. When first inserting dowels, locate the appropriate hole for the dowel, place a small amount of glue in the hole and insert the dowel. Wipe away excess glue immediately.

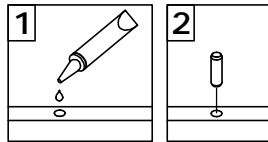

In future assembly steps when dowels are necessary to attach assembly parts together, place a small amount of glue on the end of the dowel before attaching parts together. Wipe away excess glue immediately.

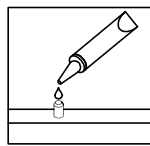

- VI. A Phillips head screwdriver is required for the assembly of this product .

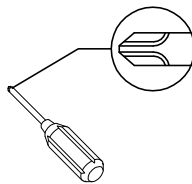

- VII. Power tools should not be used to assemble this product.

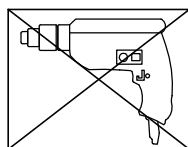





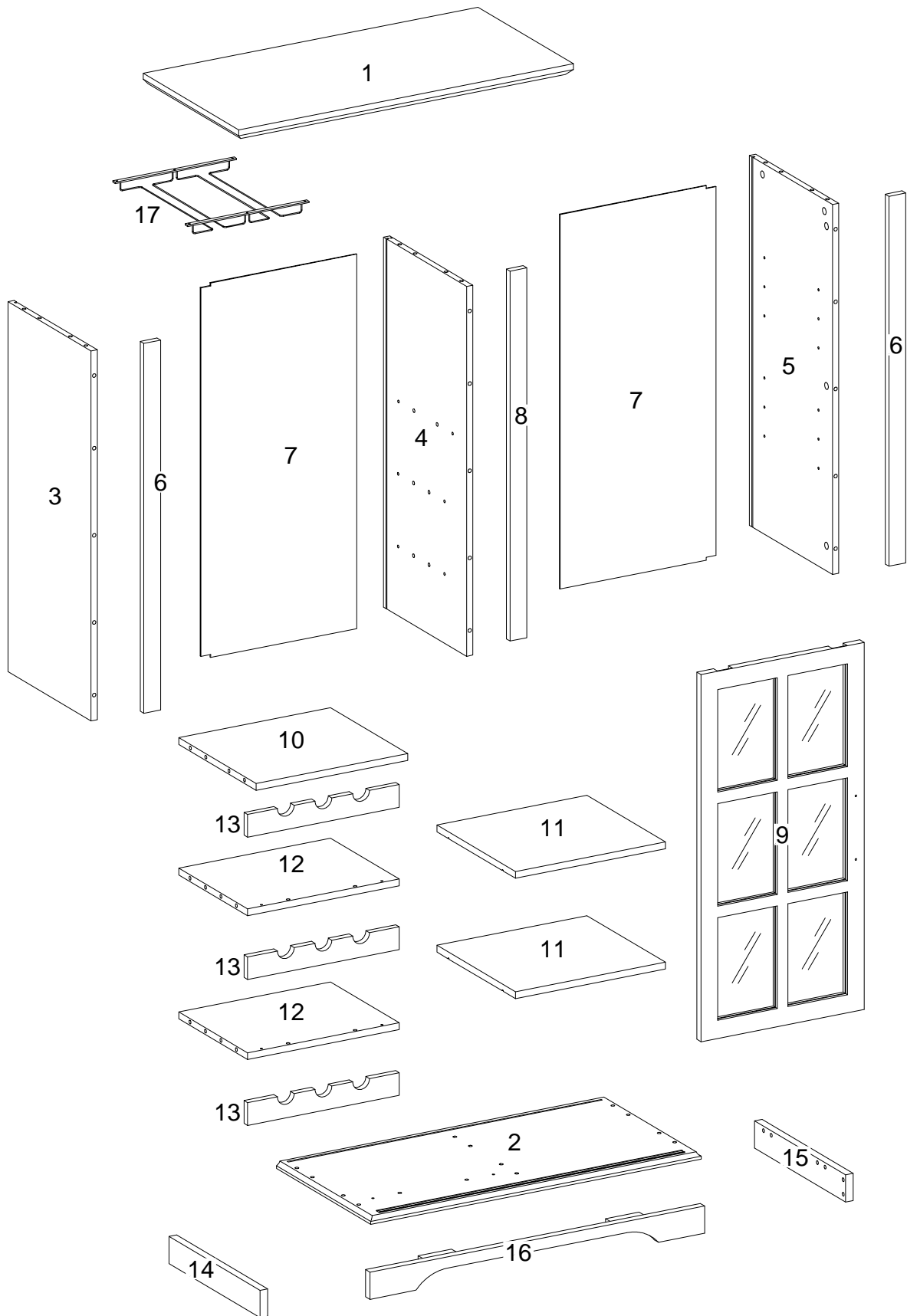



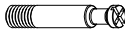

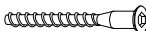
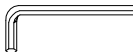







- VIII. Drill may be needed for securing product to wall.

Parts List

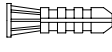

Hardware List

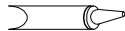
A		Ø8x30mm	Wooden dowel	36 pcs
B		Ø6x35mm	Cam bolt	27 pcs
C		Ø15x11mm	Cam lock	27 pcs
D			Sticker	27 pcs
E		Ø6x50mm	Bolt	6 pcs
F		M 4	Hex Key	1 pc
G			Plastic wedge	8 pcs
H		Ø6x12mm	Bolt	16 pcs
J		Ø4x32mm	Screw	6 pcs
K			Handle	1 pc
L		Ø4x22mm	Handle Bolt	2 pcs
M		Ø3.5x14mm	Screw	6 pcs
N			Plastic wedge	8 pcs
P		Ø3x17mm	Screw	8 pcs
Q			Pulley	2 pcs
R			Pulley	2 pcs
S		Ø3x12mm	Screw	16 pcs
T			Shelf support pin	8 pcs
U			Velcro strap	1 pc
V		Ø4x30mm	Screw	1 pc
W			Plug	1 pc
X		Ø4*15mm	Screw	1 pc
Y			Glue tube	1 pc

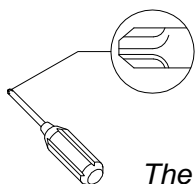

Philips head screwdriver required for assembly
(not included)

*The hardware quantities listed above are required for proper assembly.
Some extra hardware may also have been included.*

Step 1

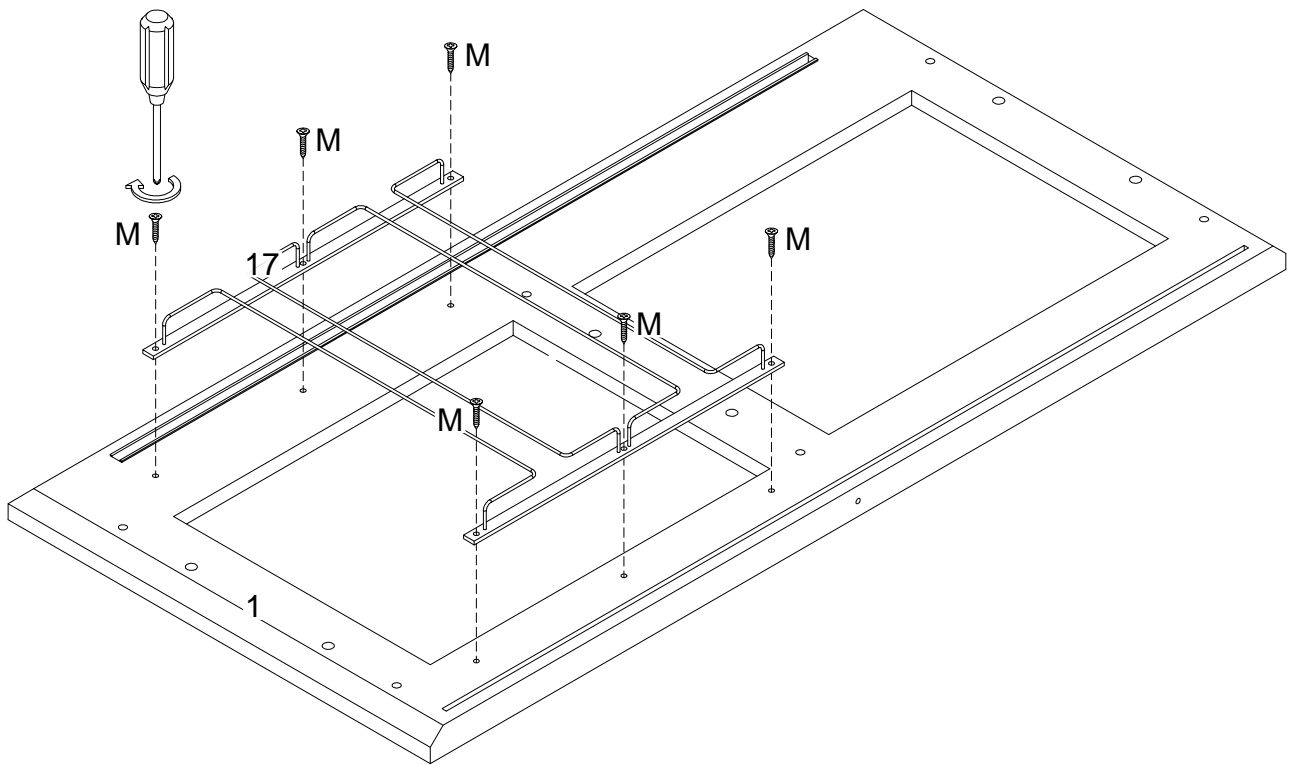

Using screw (M) attach part (17) into part (1) with Philips head screwdriver as per diagram.

Step 2

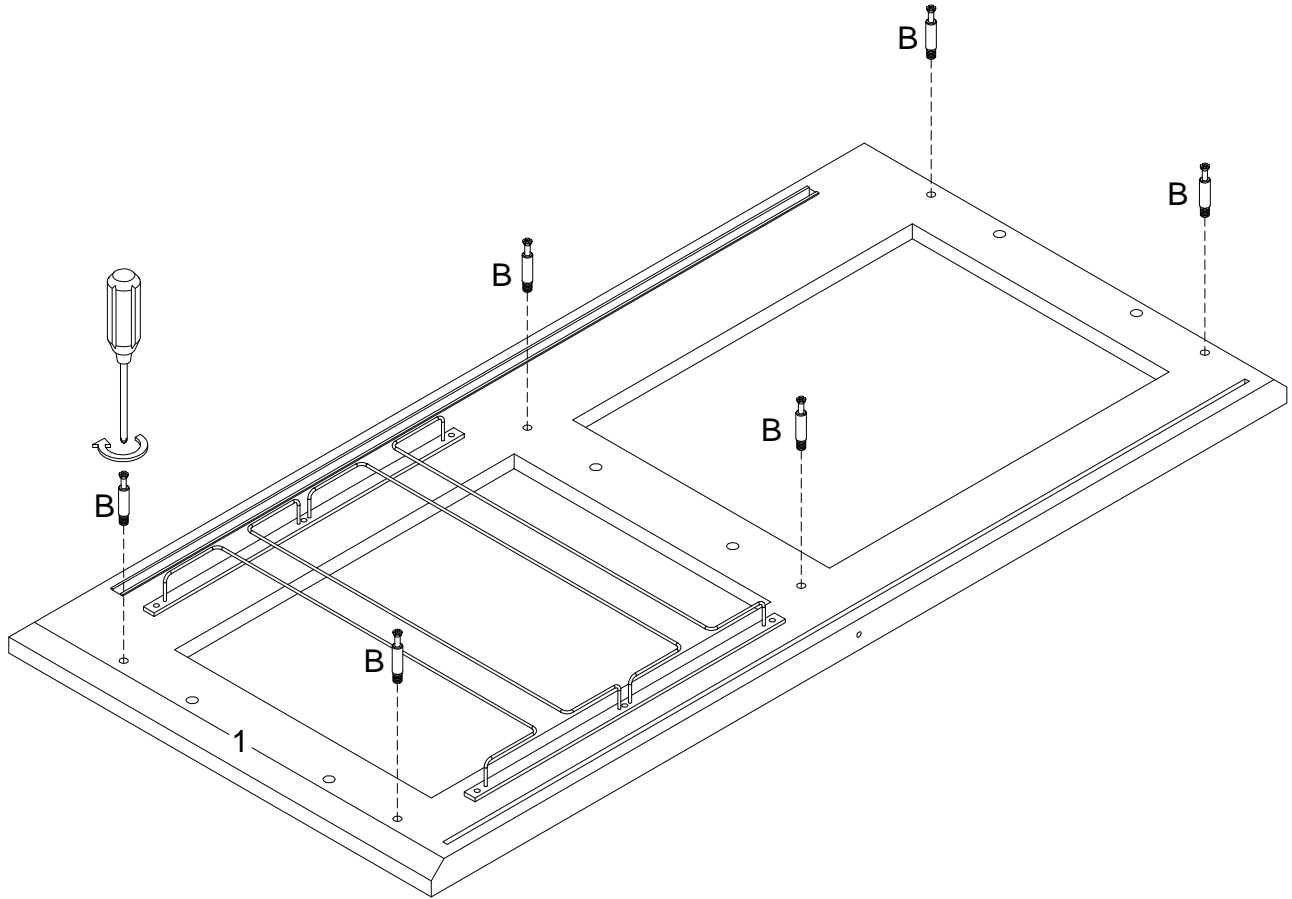

Secure cam bolt(B) to part (1) with Philips head screwdriver as per diagram.

Step 3

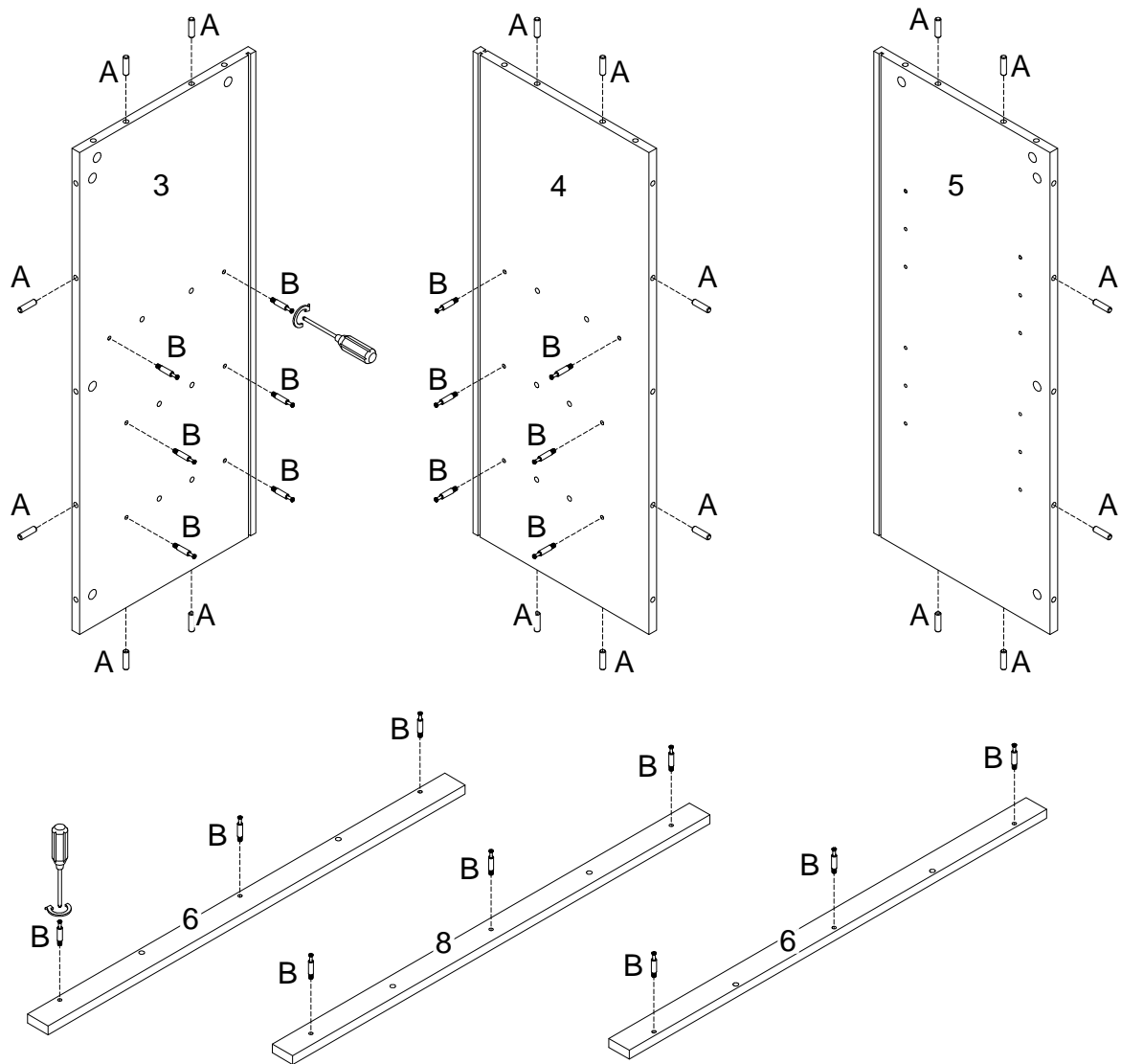

Insert wooden dowel (A) into parts (3,4,5) , secure cam bolt (B) to parts (3,4,6,8) with Philips head screwdriver as per diagram.

Step 4

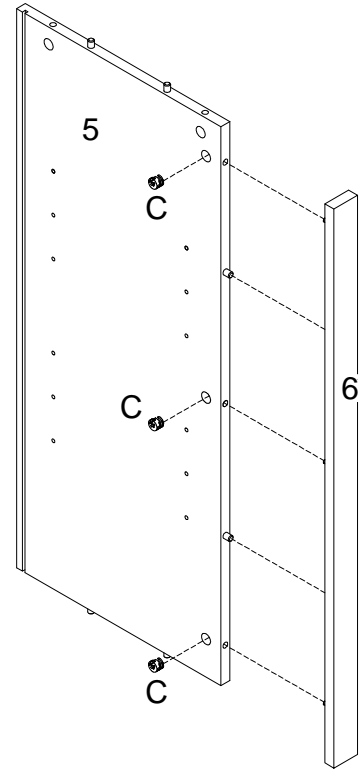
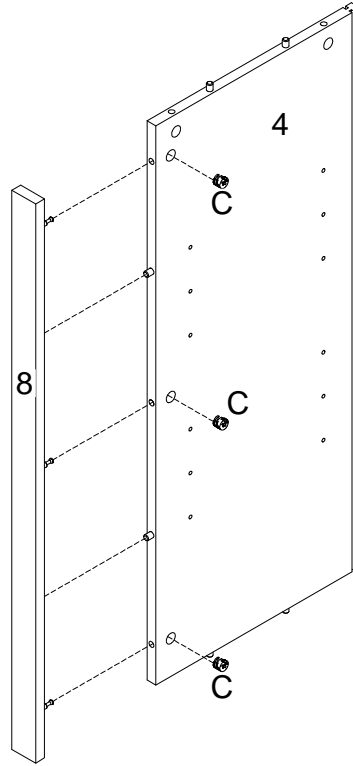
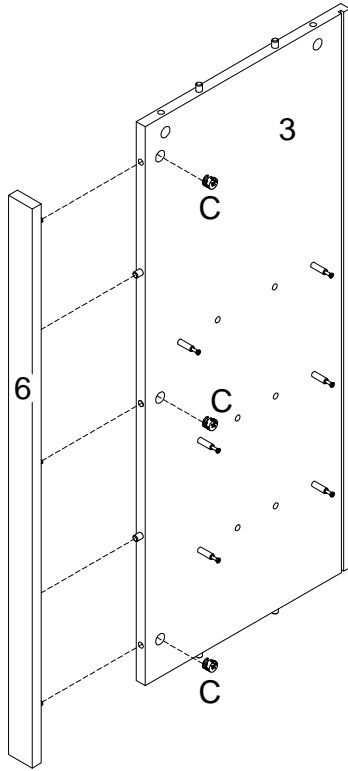
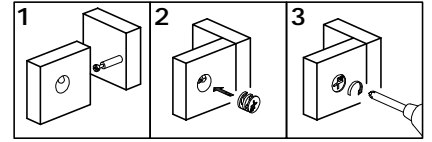

Using cam lock(C) secure part (6) to parts (3,5) ,part (8) to part (4) with Philips head screwdriver as per diagram.

Step 5

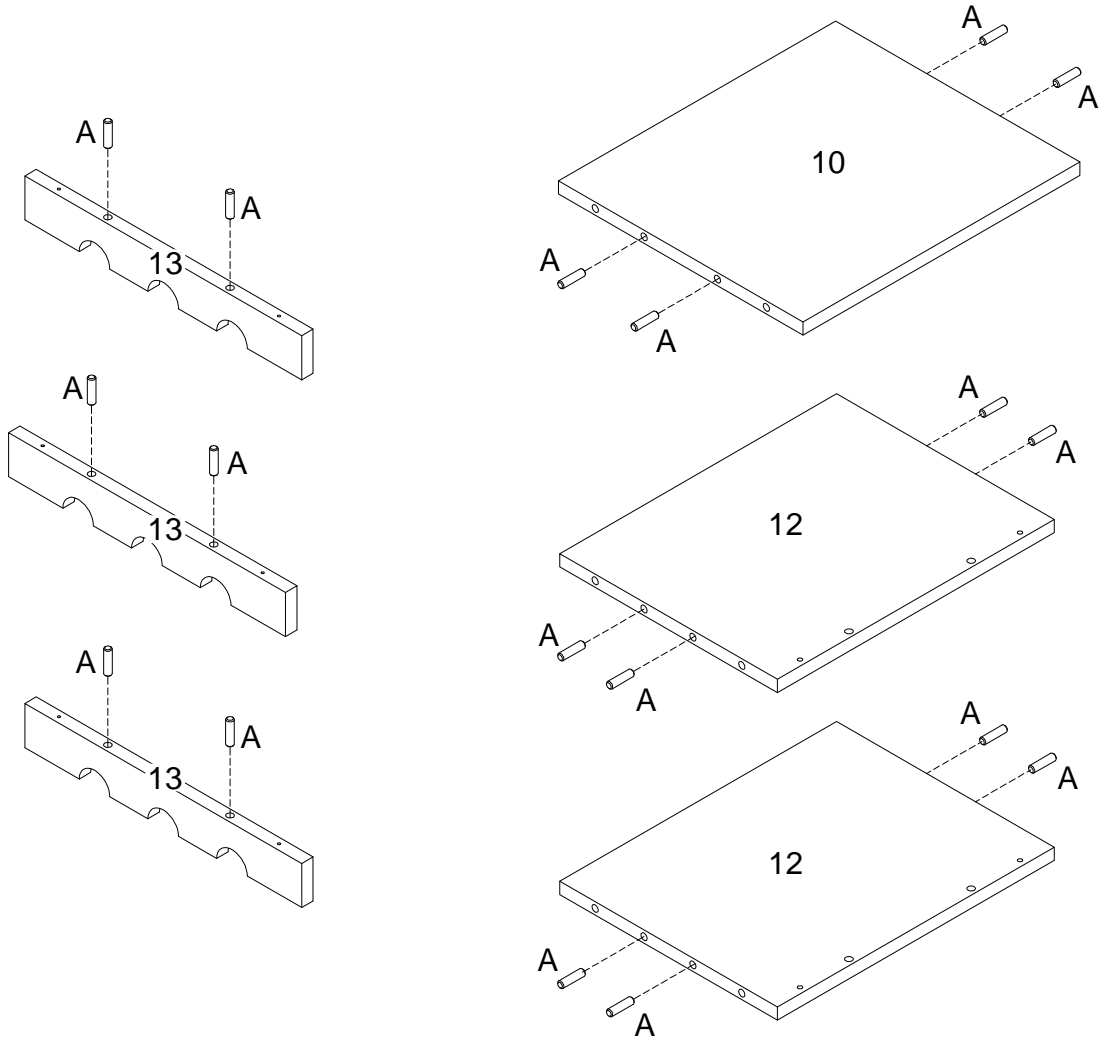

Insert wooden dowel (A) into parts (10,12,13) as per diagram.

Step 6

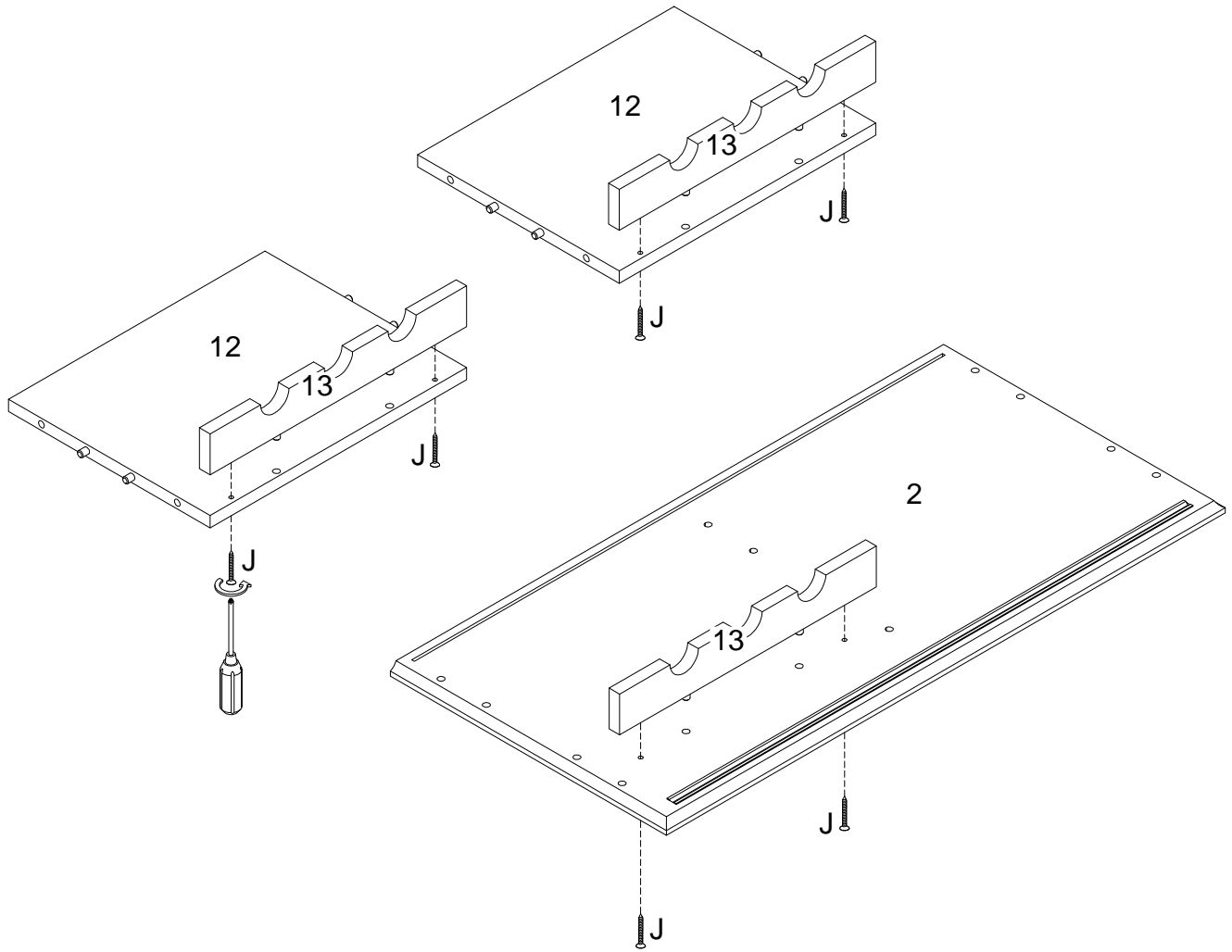

Using screw (J) attach part (13) into parts (2,12) with Philips head screwdriver as per diagram.

Step 7

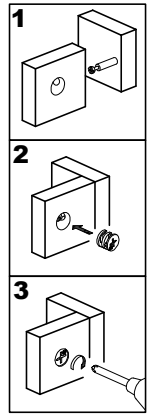
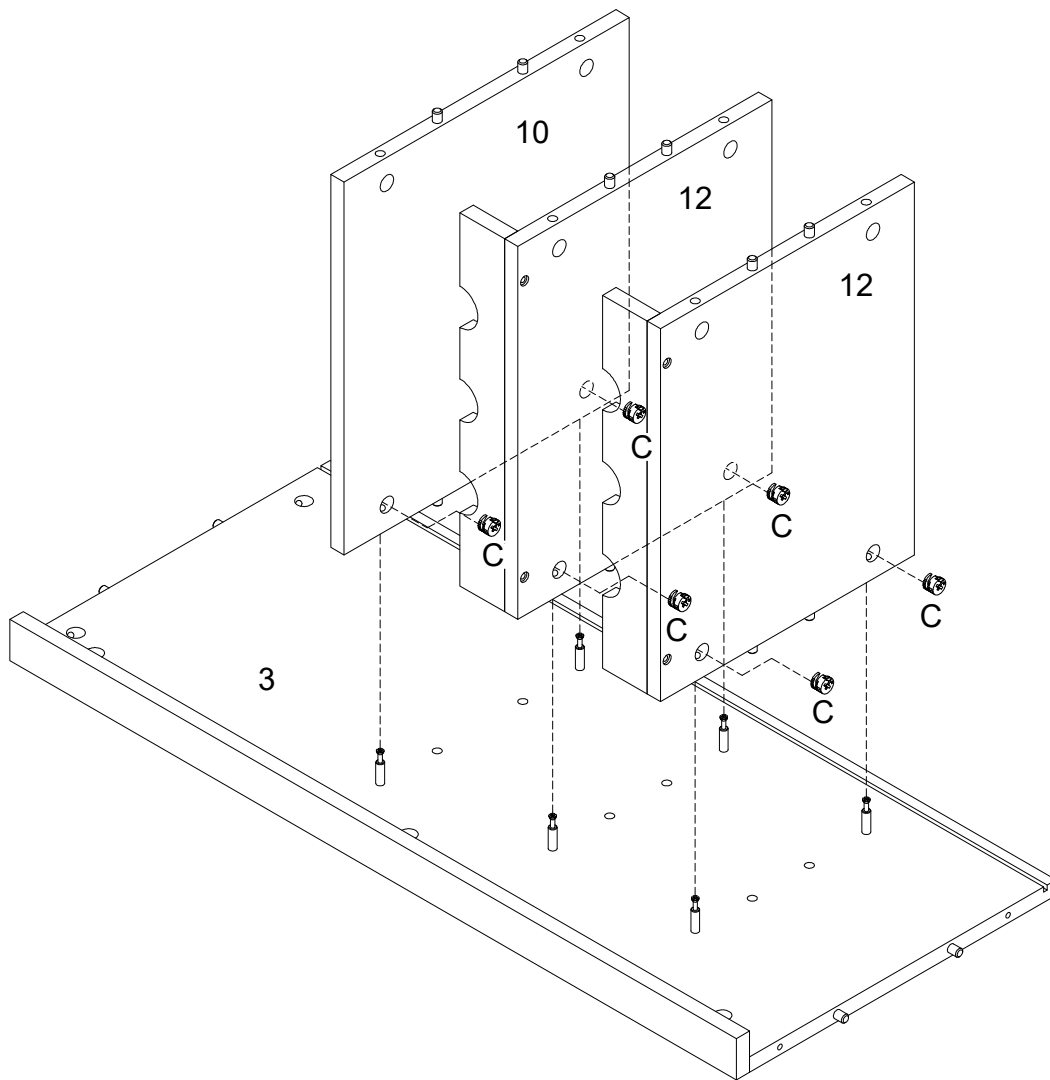

Using cam lock(C) secure parts (10,12) to part (3) with Philips head screwdriver as per diagram.

Step 8

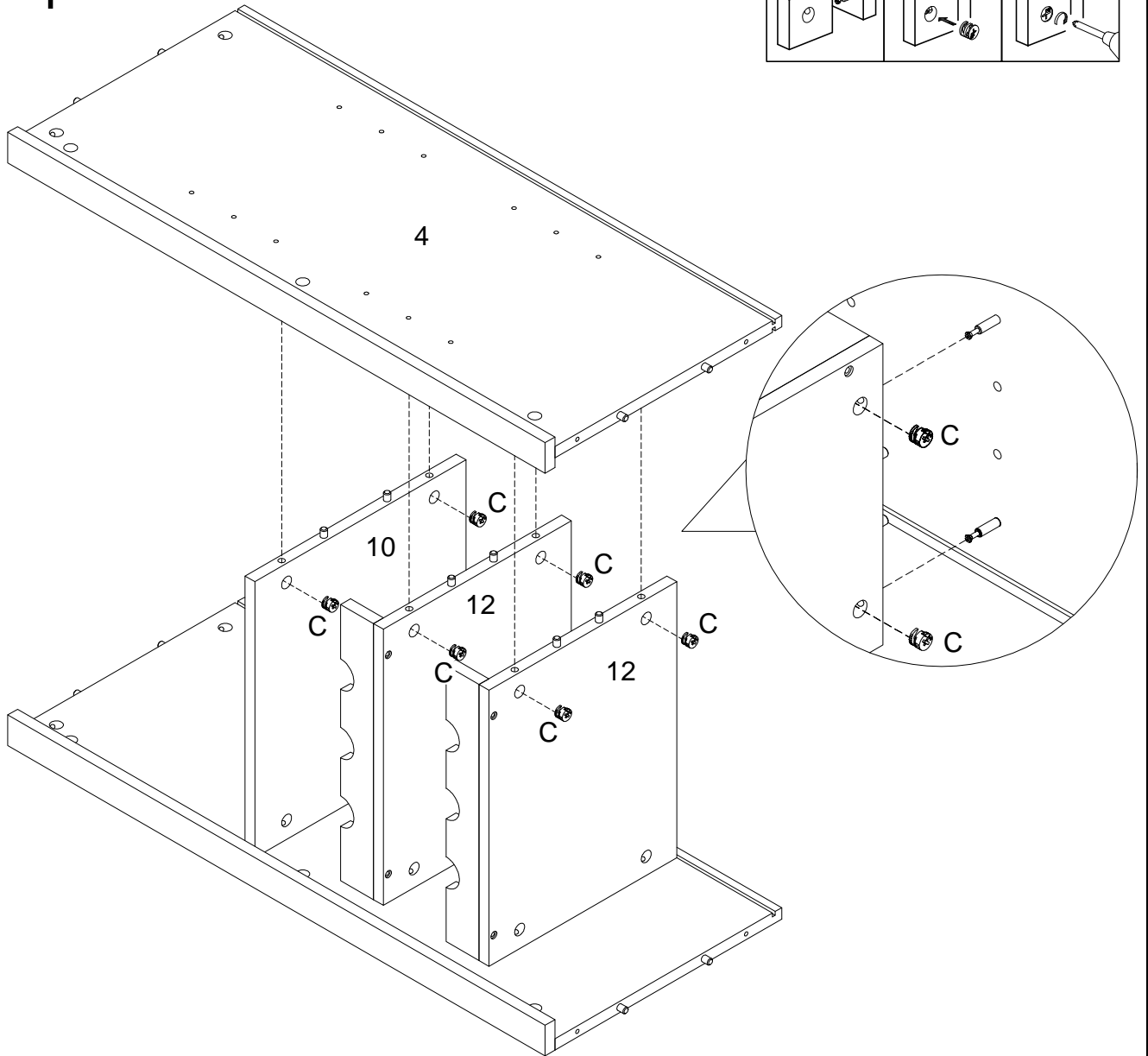
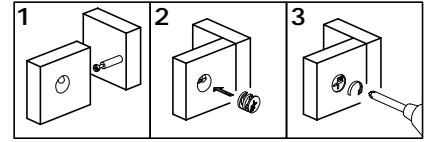

Using cam lock(C) secure part (4) to parts (10,12) with Philips head screwdriver as per diagram.

Step 9

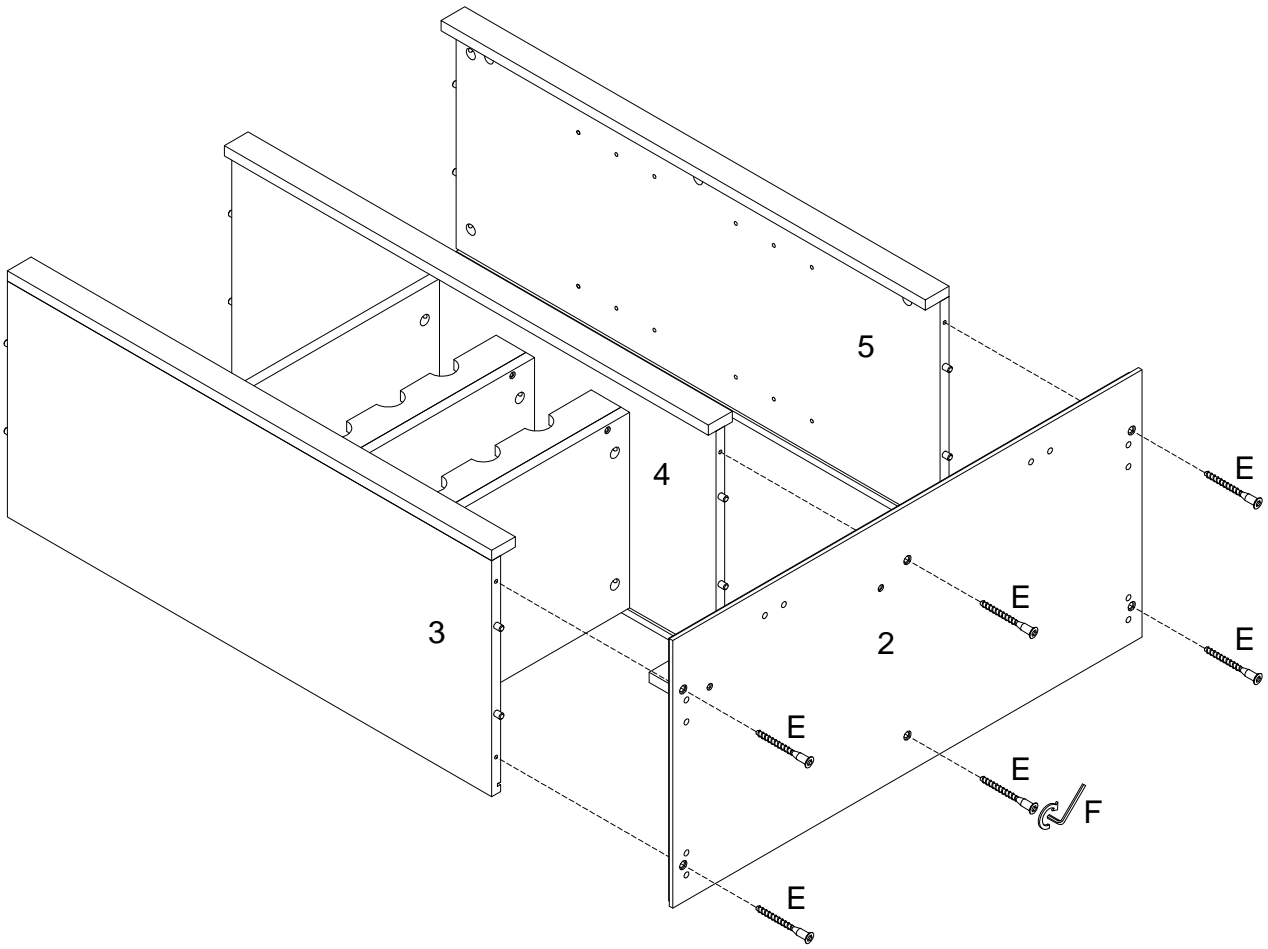

Using bolt (E) attach part (2) into parts (3,4,5) with hex key (F) as per diagram.

Step 10

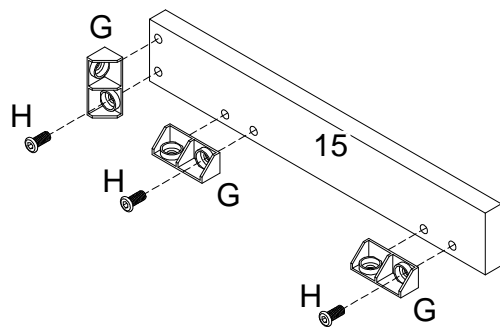
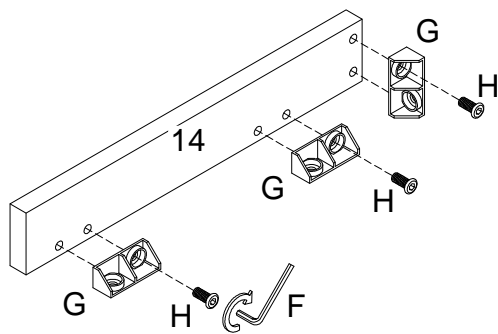
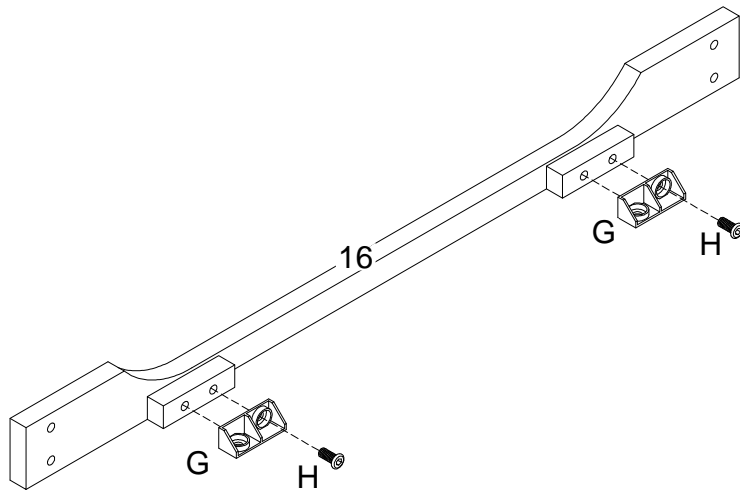

Using bolt (H) secure plastic wedge (G) to parts (14,15,16) with hex key (F) as per diagram.

Step 11

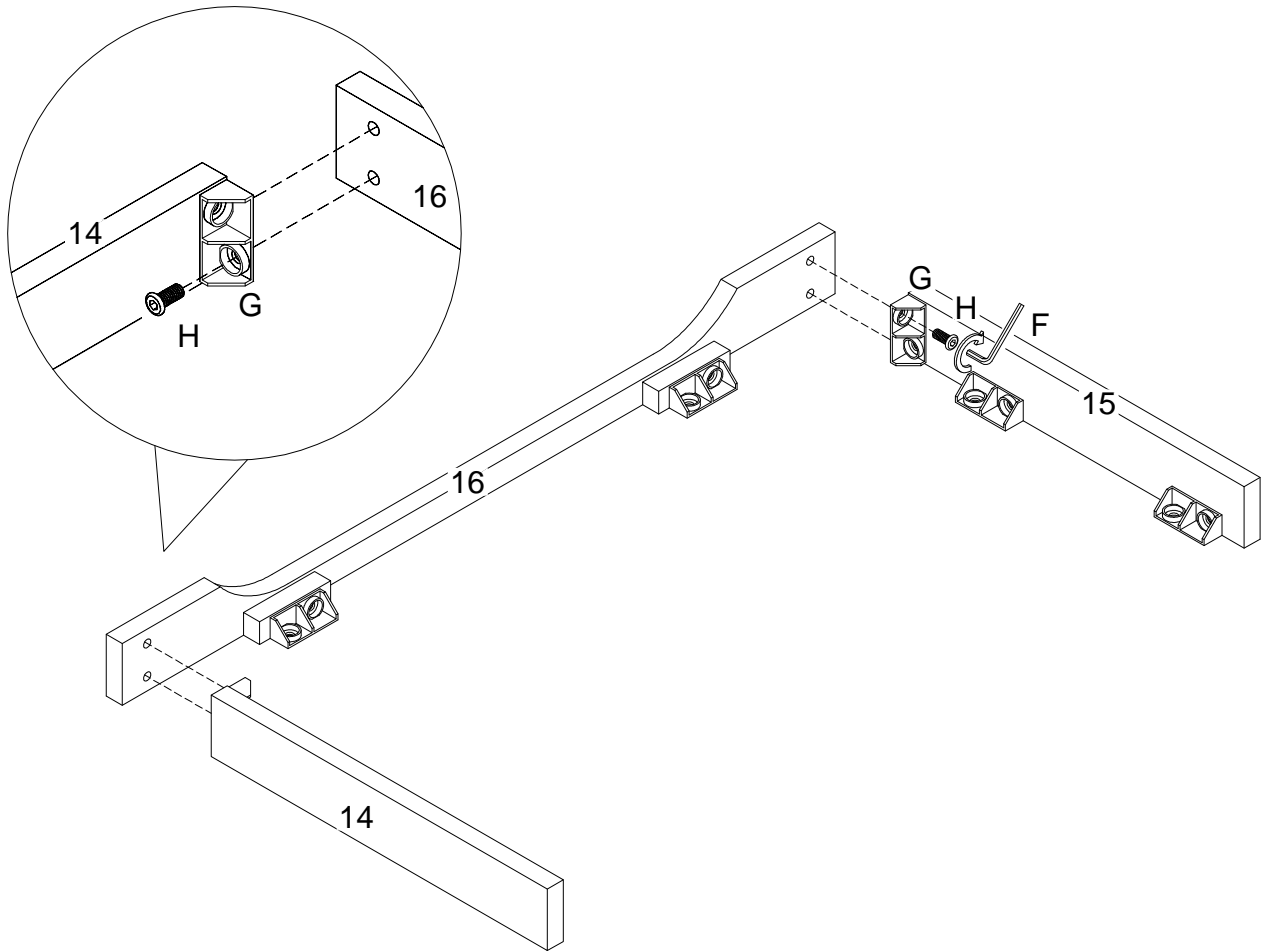

Using bolt (H) secure plastic wedge (G) on parts (14,15) to part (16) with hex key (F) as per diagram.

Step 12

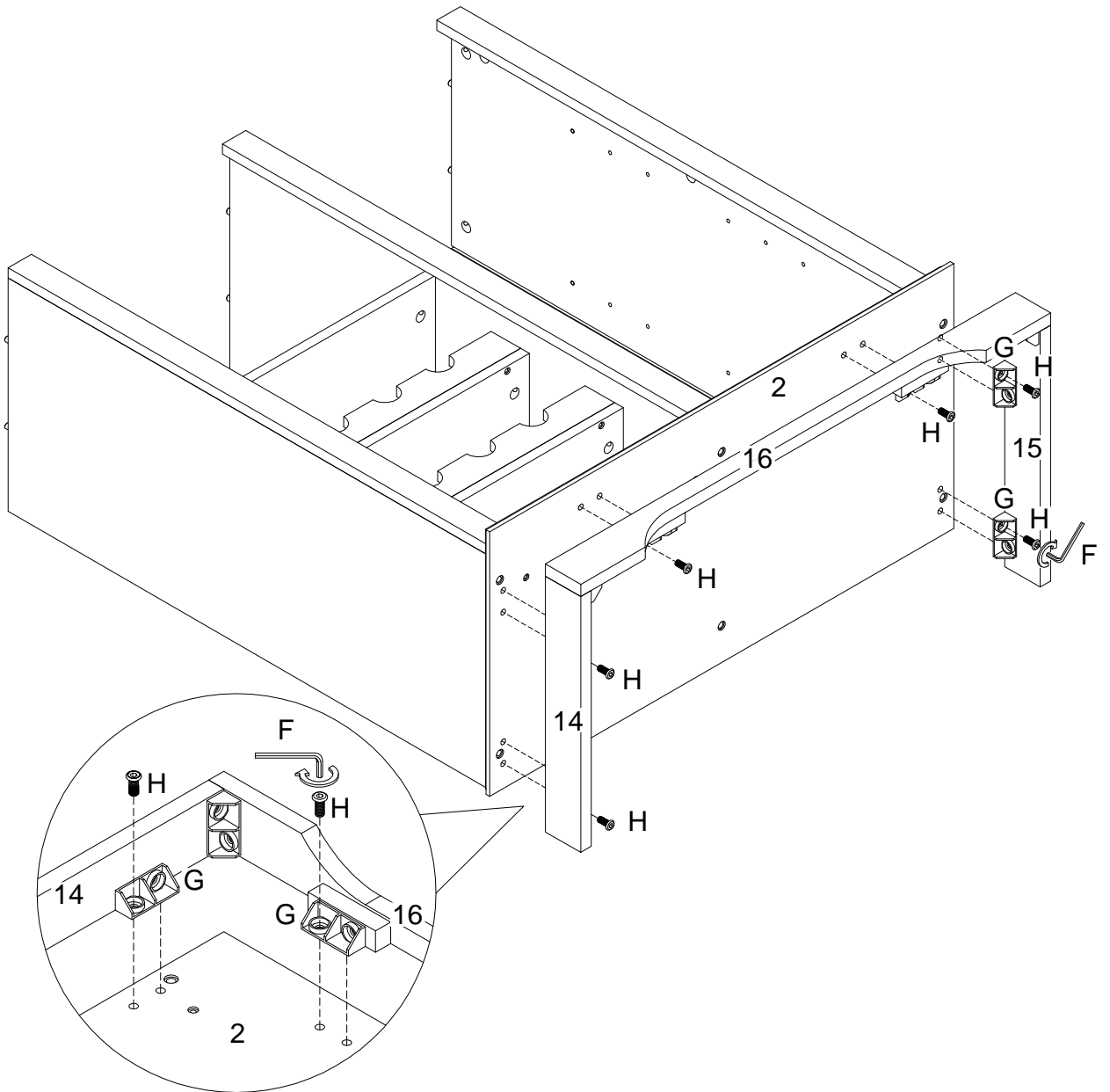

Using bolt (H) attach plastic wedge (G) on parts (14,15,16) to part (2) with hex key (F) as per diagram.

Step 13

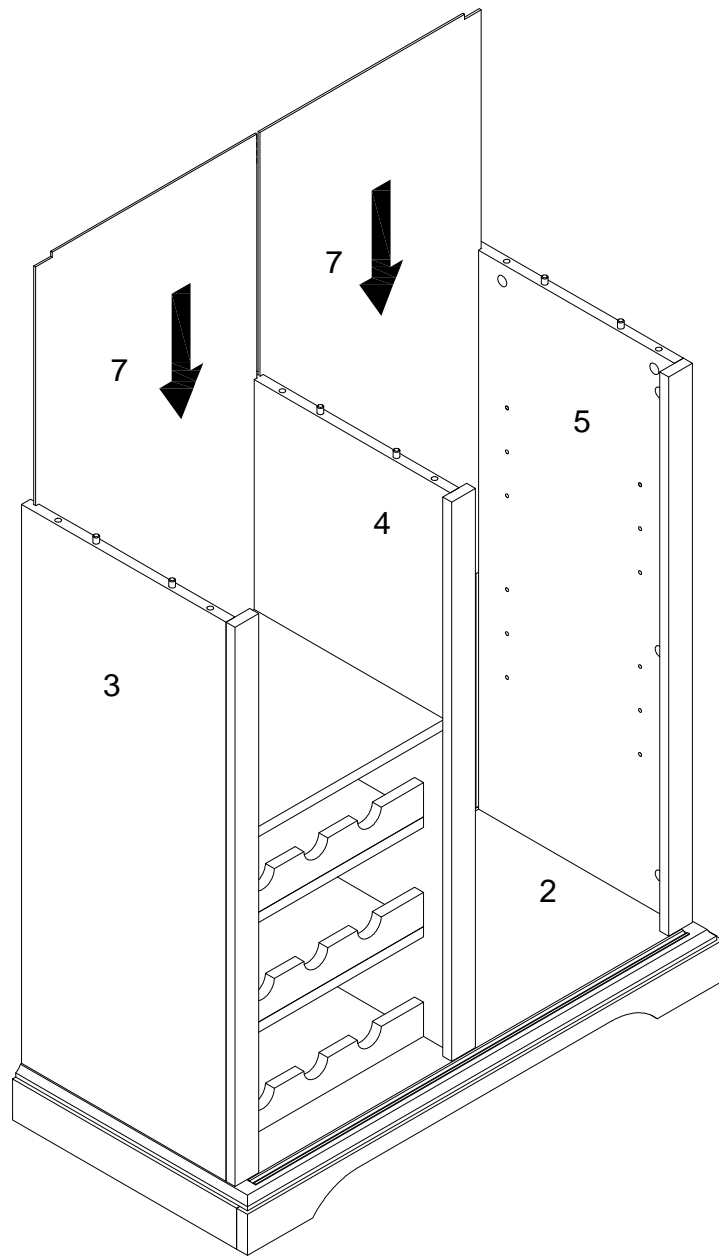

Put part (7) into parts (2,3,4,5) as per diagram.

Step 14

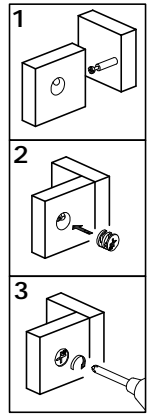
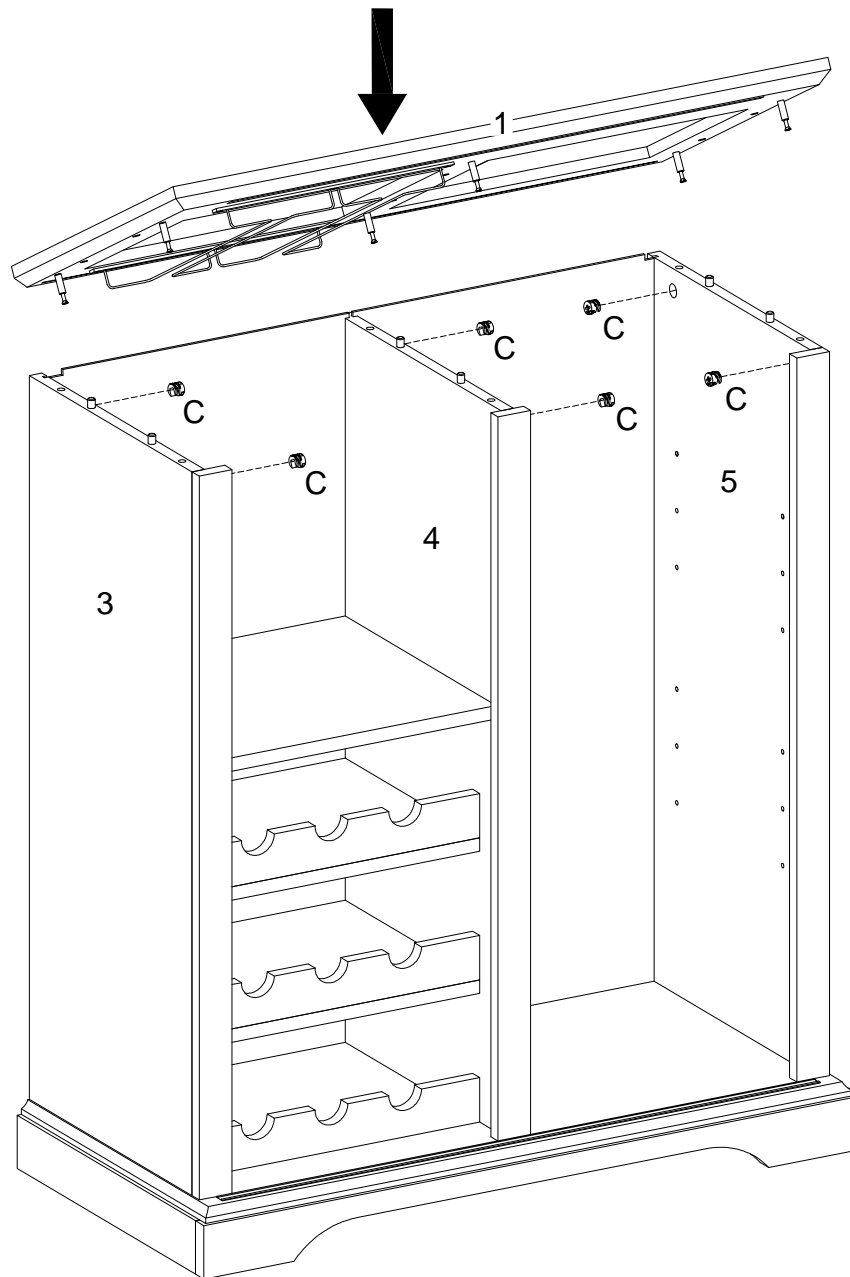

Using cam lock(C) secure part (1) to parts (3,4,5) with Philips head screwdriver as per diagram.

Step 15

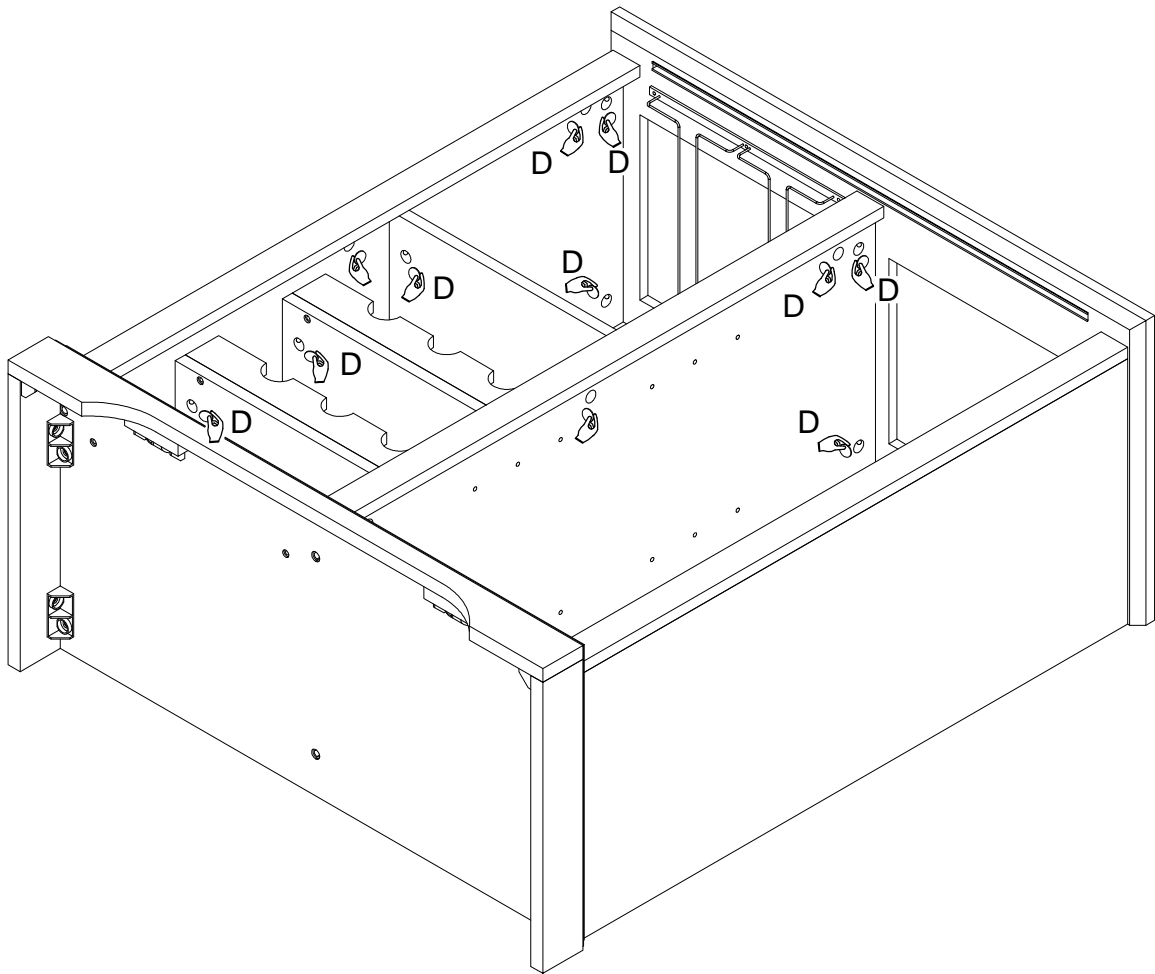

Place sticker (D) cover the holes as per diagram .

Step 16

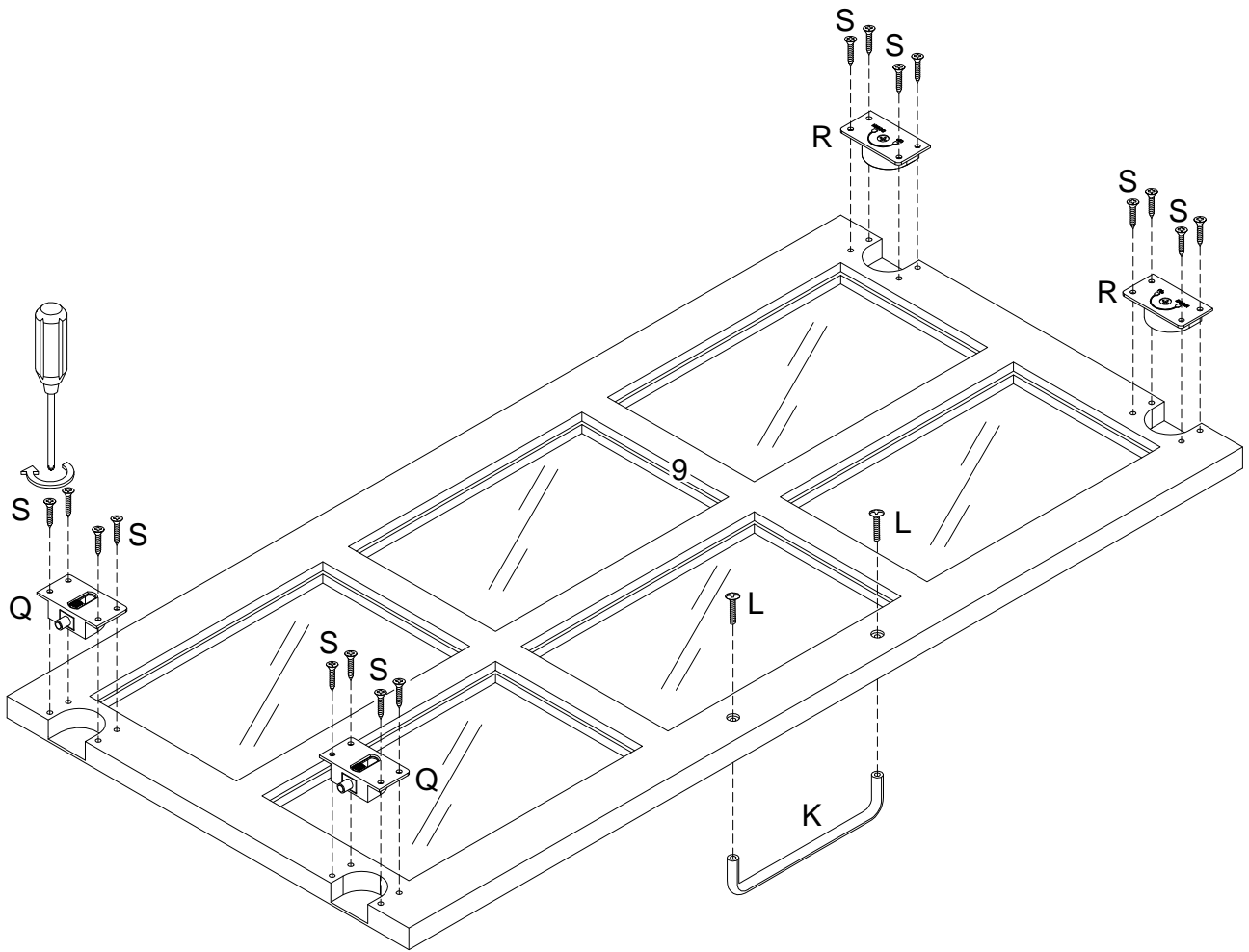

Using screw (S) attach parts (R) and (Q) into part (9), then using handle bolt (L) attach handle (K) into part (9) with Philips head screwdriver as per diagram.

Step 17

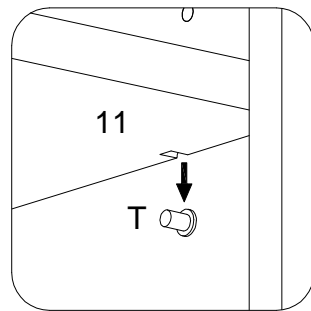
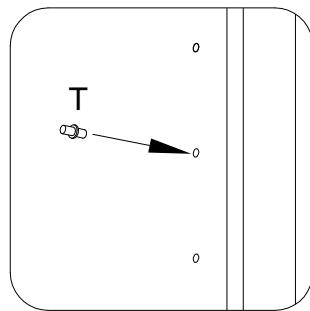
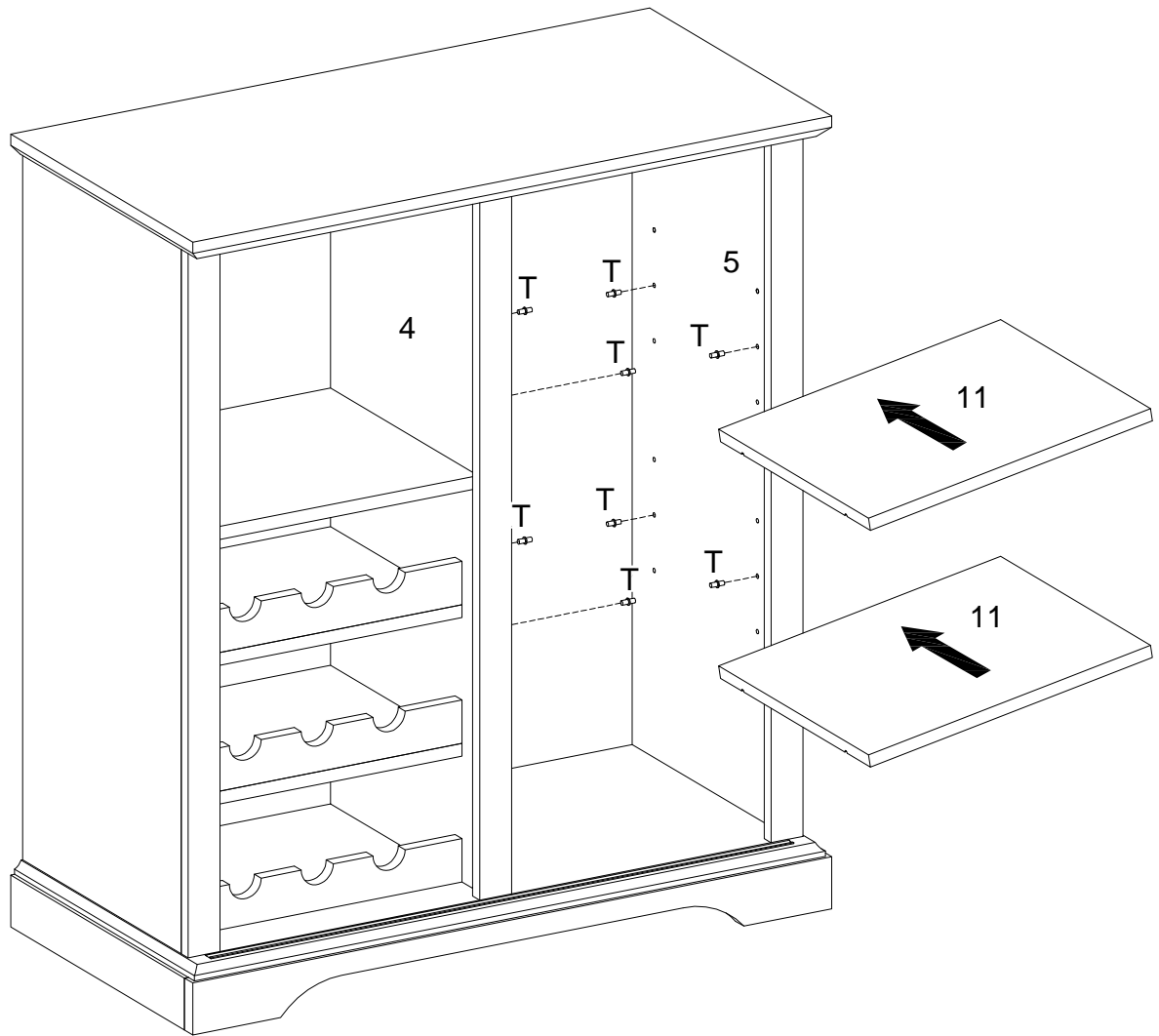

Insert shelf support pin (T) into parts (4,5) as per diagram. Make sure you place the four shelf support pins (T) in the same level. So the shelf is not tilted. Put part (11) into unit as per diagram. Tilt and rest the adjustable shelf (11) onto the shelf support pins.

Step 18

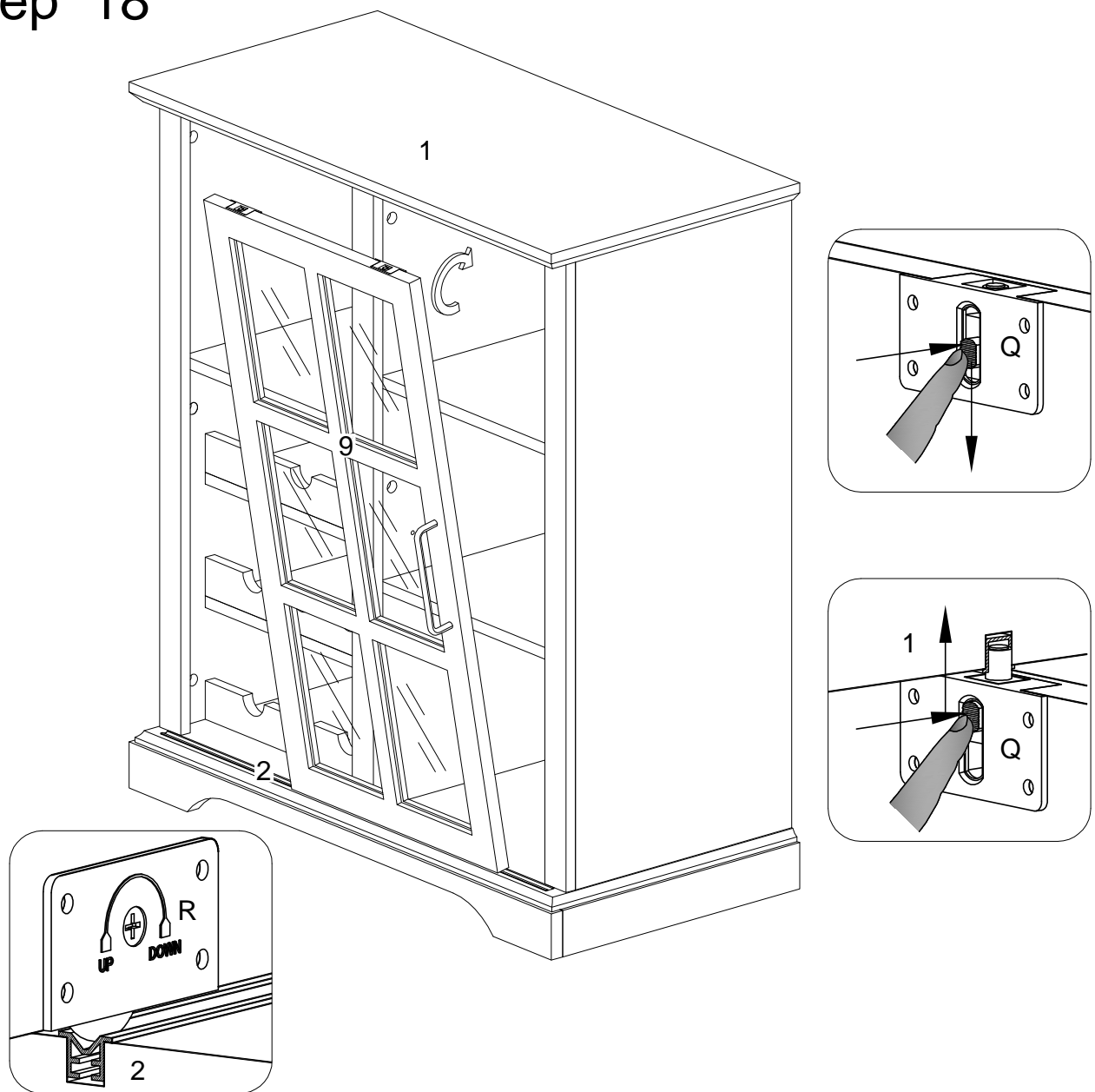

Pick up the door (9), and fit the pulley (R) over the slider rails on the bottom panel (2), then place the pulley (Q) into top panel (1), till it click into pulley (R) as per diagram.

Step 19

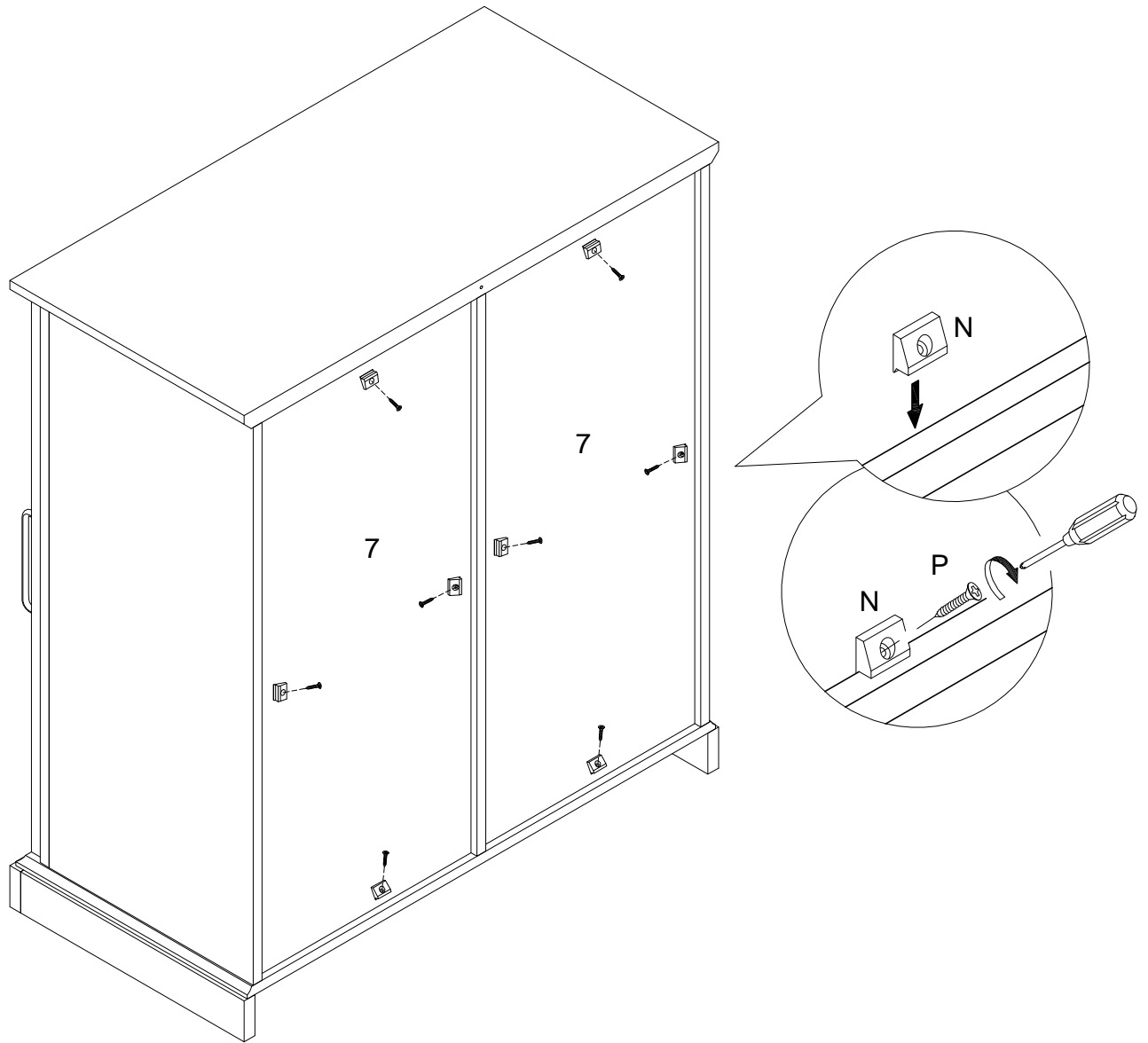

Using screw (P) secure plastic wedge (N) to part (7) with Philips head screwdriver as per diagram.

Step 20

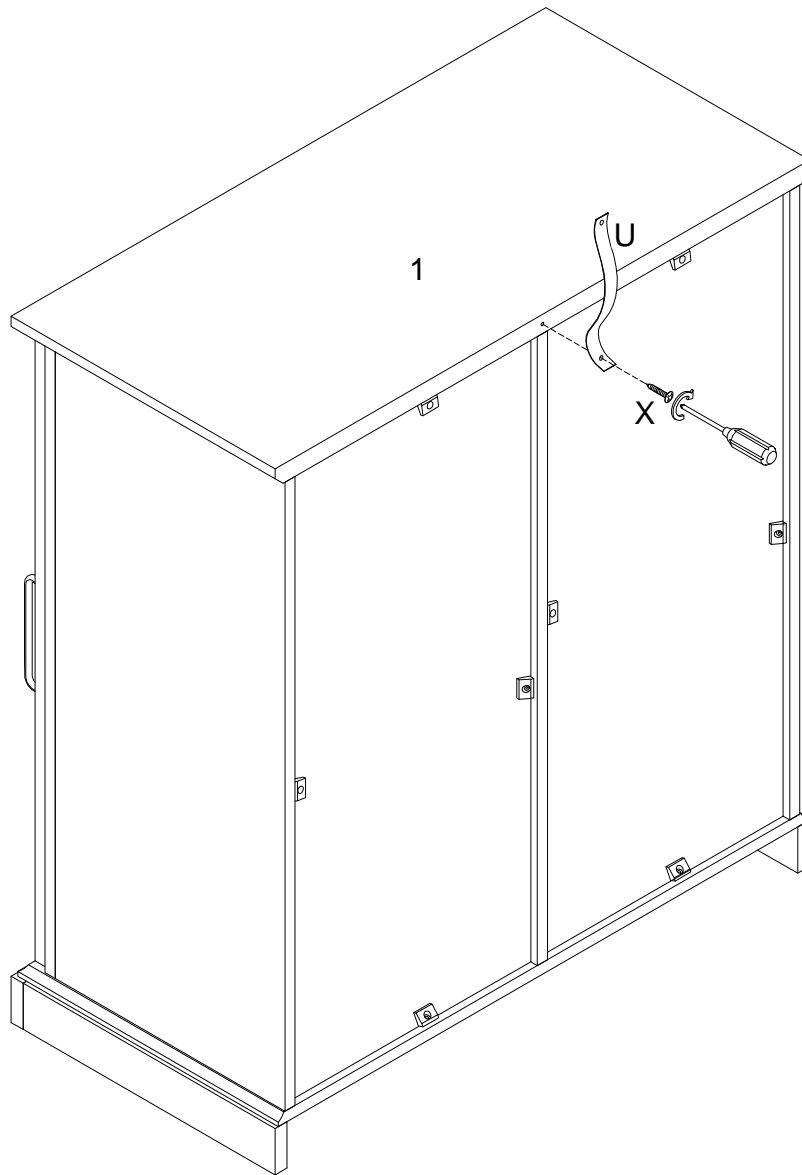

Using screw (X) attach velcro strap (U) into part (1) with Philips head screwdriver as per diagram.

Step 21

WARNING

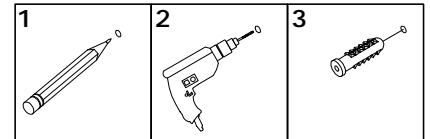

Serious or fatal injuries can occur from furniture tipping over. To prevent the furniture from tipping over we recommend that it is permanently fixed to the wall. Wall anchor and hardware are included with this product. Please make sure hardware is suitable for your walls before installing, as different wall materials may require different types of anchors.

Wall

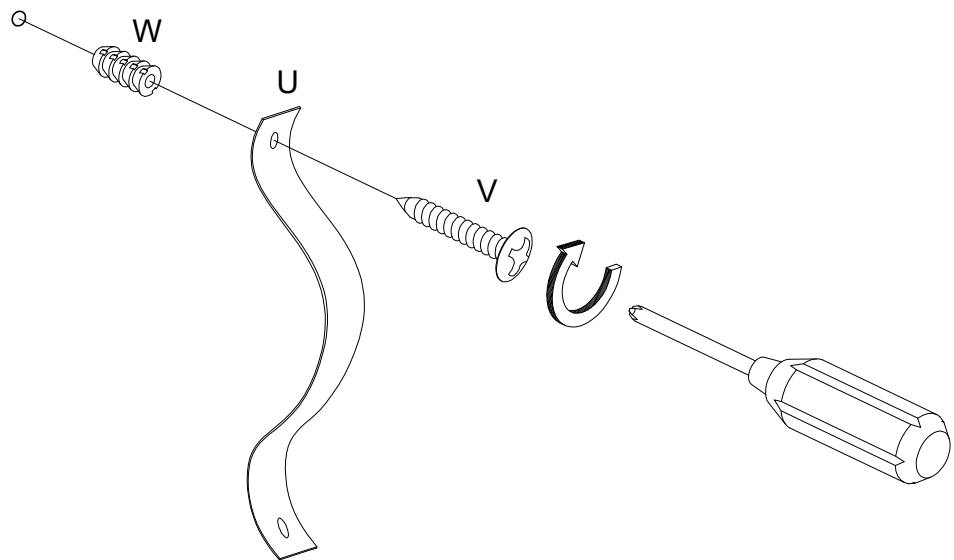

Using screw (V) attach Velcro strap (U) into plug (W) to wall with Philips head screwdriver as per diagram.

Step 22

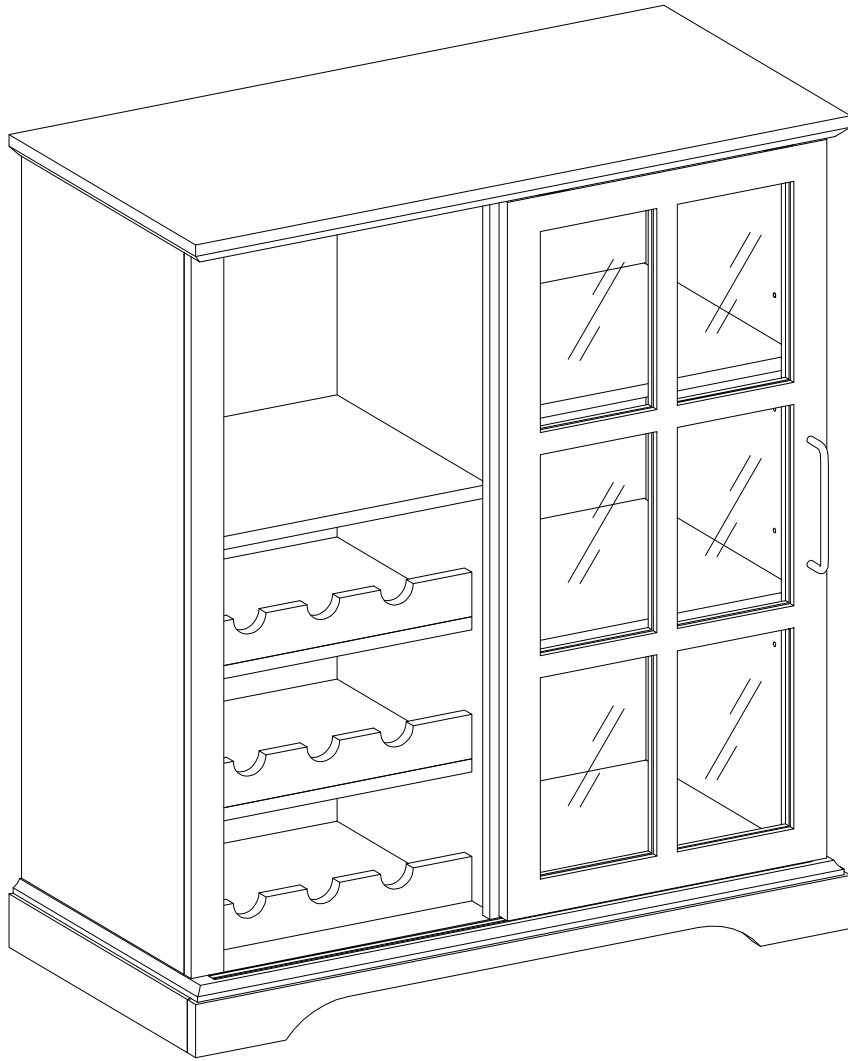

Final Assembly