

Assembly Instruction

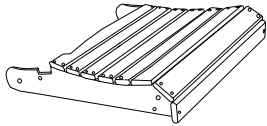

A x 1

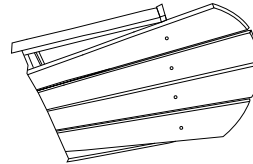

F x 1

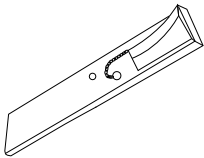

B x 1

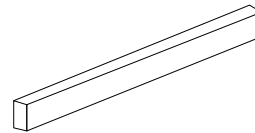

G x 1

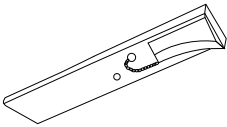

C x 1

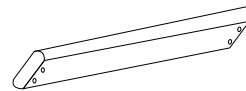

H x 1

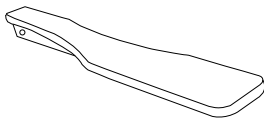







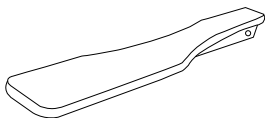

D x 1

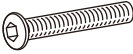

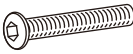
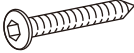
I x 2

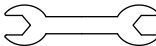

E x 1

| | | | | | |
|----|---|----|---|----|---|
| 1: | M6 x80mm BOLT  2 PCS | 2: | M6 x 60mm BOLT  4 PCS | 3: | M6 x 50mm BOLT  4 PCS |
| 4: | M6.3 x 50mm BOLT  2 PCS | 5: | M6 x 30mm BOLT  4 PCS | 6: | M6 NUT  8 PCS |
| 7: | M6 WASHER  8 PCS | 8: | WRENCH  1 PC | 9: | ALLEN WRENCH  1 PC |



NOTE: UNIT SHOULD BE ASSEMBLED BY TWO OR MORE PEOPLE.
DO NOT TIGHTEN ANY BOLTS UNTIL ALL BOLTS HAVE BEEN STARTED!

PRODUCT ASSEMBLY - OVERALL VIEW

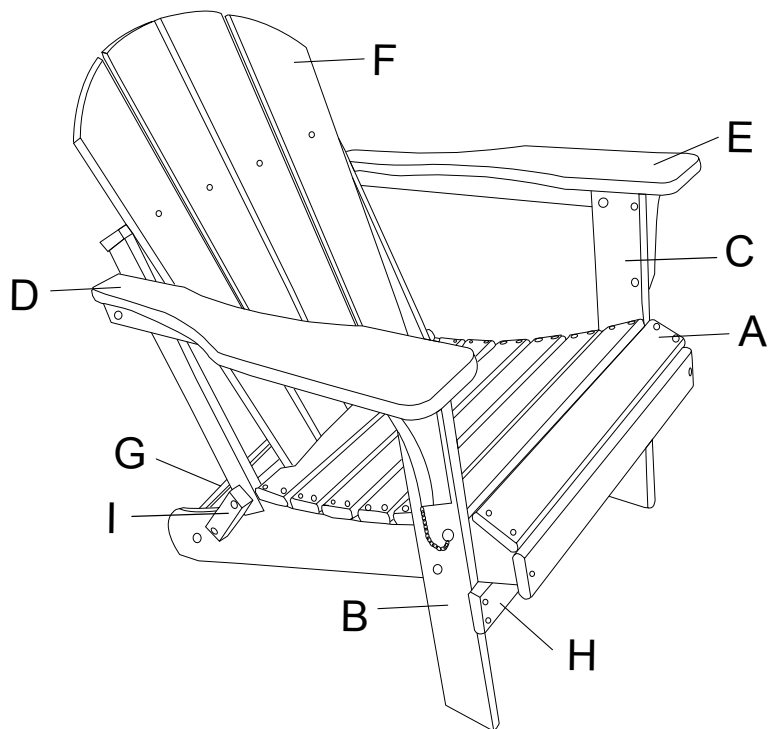

STEP1 :

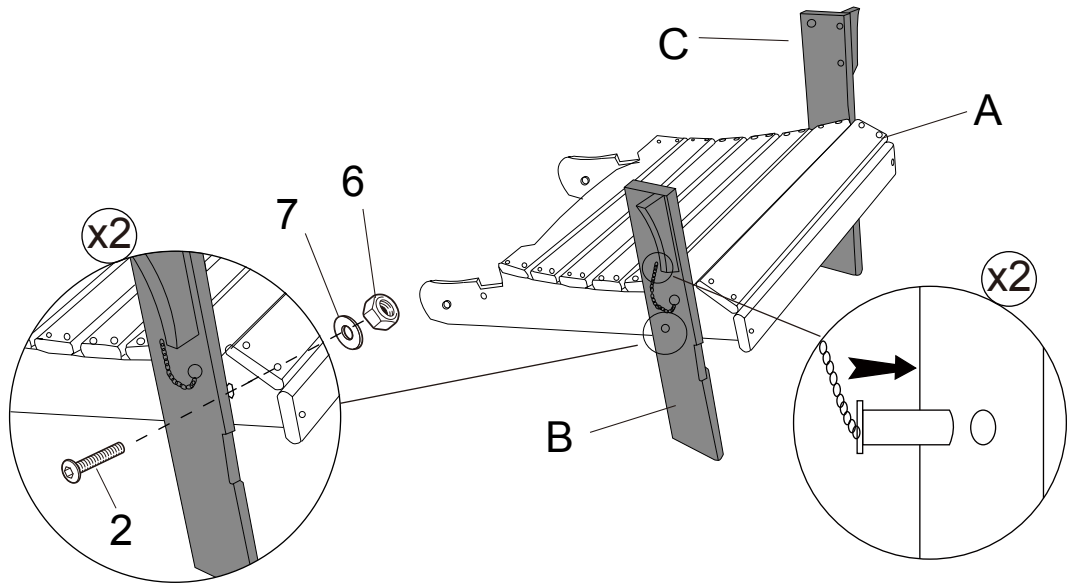

STEP2 :

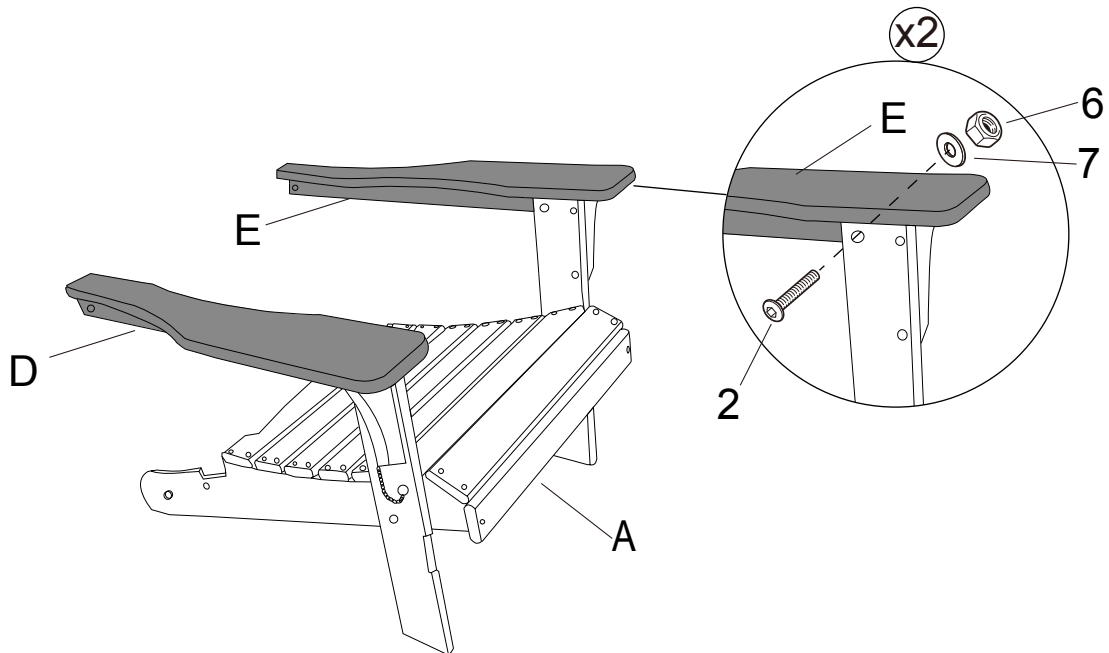

STEP3 :

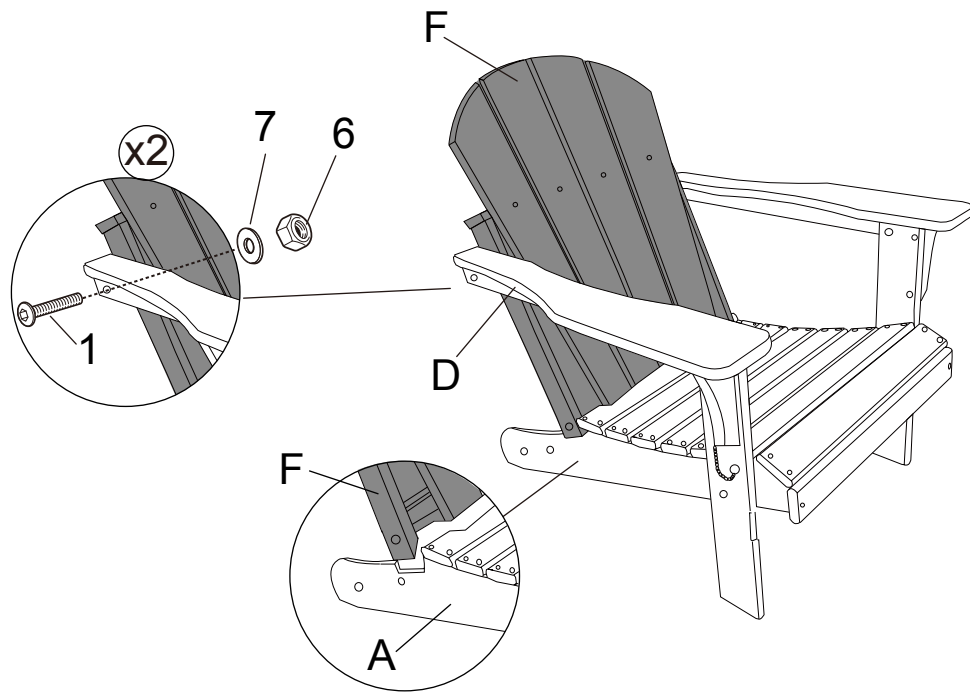

STEP4 :

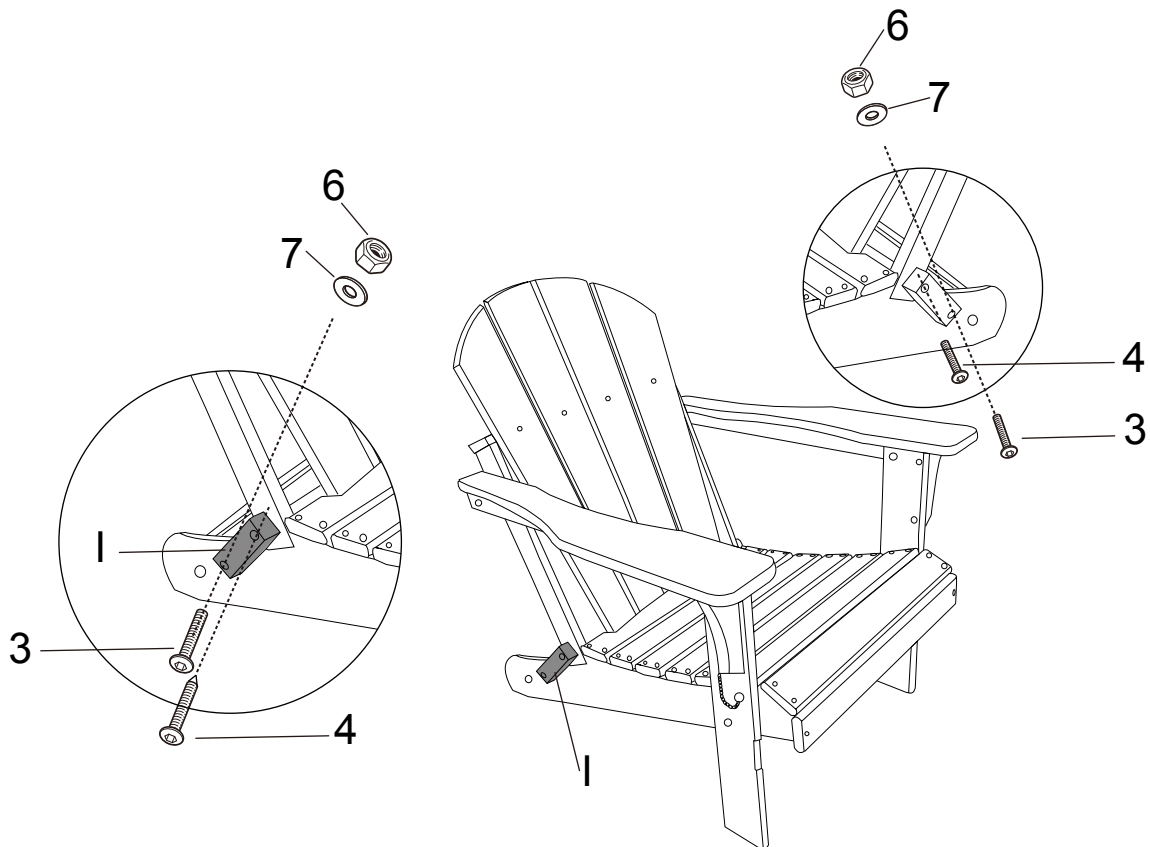

STEP5 :

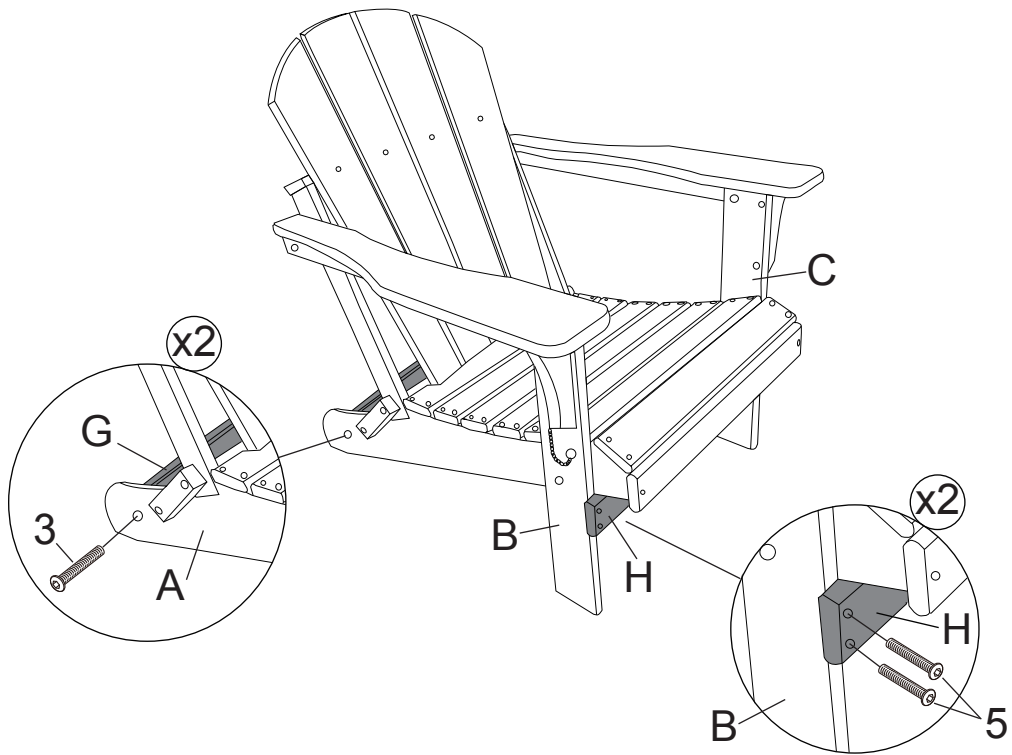

STEP6 :

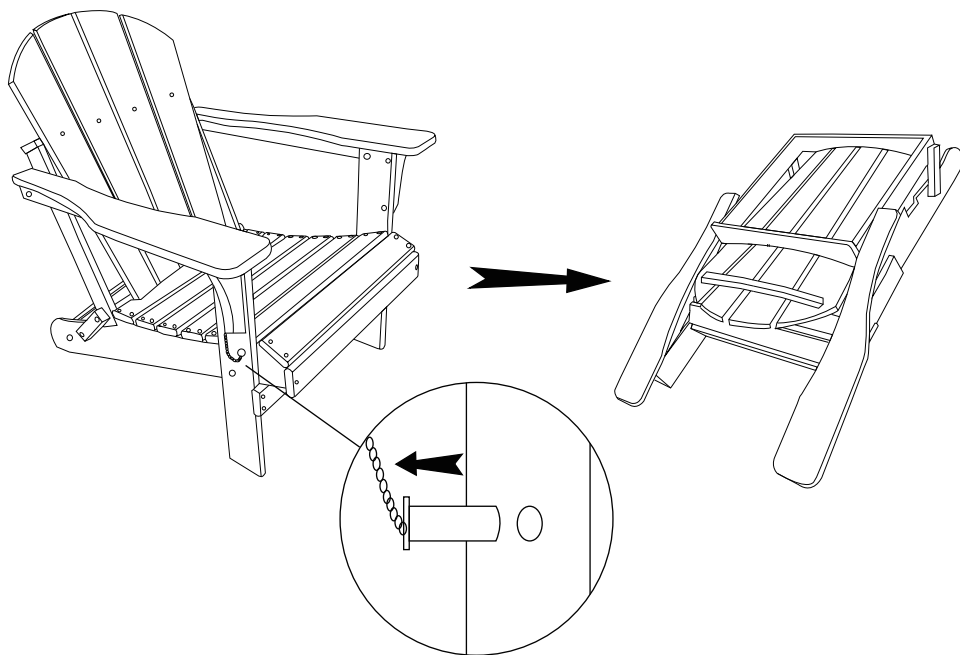

Complete assembly and tighten all screws.